

RF LDMOS Wideband Integrated Power Amplifiers

The MMRF2005N wideband integrated circuit is designed with on-chip matching that makes it usable from 728 to 960 MHz. This multi-stage structure is rated for 24 to 32 V operation and is ideal for applications including radio communications, data links and UHF radar.

Driver Application — 900 MHz

- Typical Single-Carrier W-CDMA Performance: $V_{DD} = 28$ Vdc, $I_{DQ1} = 106$ mA, $I_{DQ2} = 285$ mA, $P_{out} = 3.2$ W Avg., IQ Magnitude Clipping, Channel Bandwidth = 3.84 MHz, Input Signal PAR = 7.5 dB @ 0.01% Probability on CCDF.

Frequency (1)	G_{ps} (dB)	PAE (%)	ACPR (dBc)
920 MHz	36.6	16.1	-48.0
940 MHz	36.8	16.7	-48.7
960 MHz	36.6	17.3	-48.6

- Capable of Handling 10:1 VSWR, @ 32 Vdc, 940 MHz, 48 W CW Output Power (3 dB Input Overdrive from Rated P_{out})

Driver Application — 700 MHz

- Typical Single-Carrier W-CDMA Performance: $V_{DD} = 28$ Vdc, $I_{DQ1} = 106$ mA, $I_{DQ2} = 285$ mA, $P_{out} = 3.2$ W Avg., IQ Magnitude Clipping, Channel Bandwidth = 3.84 MHz, Input Signal PAR = 7.5 dB @ 0.01% Probability on CCDF.

Frequency	G_{ps} (dB)	PAE (%)	ACPR (dBc)
728 MHz	36.4	16.1	-47.7
748 MHz	36.4	16.1	-47.8
768 MHz	36.4	16.0	-47.9

Features

- Characterized with series equivalent large-signal impedance parameters and common source S-parameters
- On-chip matching (50 ohm input, DC blocked, > 5 ohm output)
- Integrated quiescent current temperature compensation with enable/disable function (2)
- Integrated ESD protection

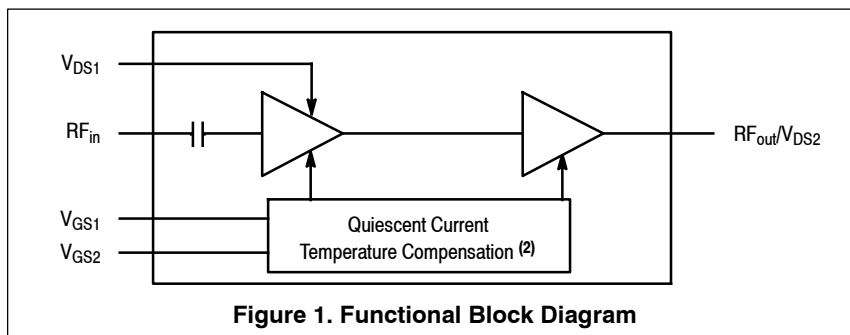

MMRF2005N
MMRF2005GN

728–960 MHz, 3.2 W AVG., 28 V
RF LDMOS WIDEBAND
INTEGRATED POWER AMPLIFIERS

TO-270WB-16
PLASTIC
MMRF2005N

TO-270WBG-16
PLASTIC
MMRF2005GN

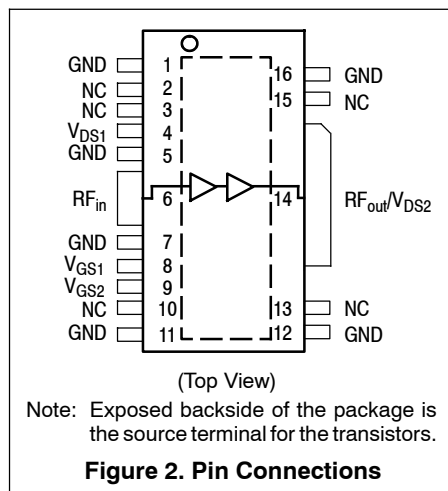

1. 900 MHz Driver Frequency Band table data collected in the 900 MHz application circuit. See Fig. 9.
2. Refer to [AN1977](#), *Quiescent Current Thermal Tracking Circuit in the RF Integrated Circuit Family*, and to [AN1987](#), *Quiescent Current Control for the RF Integrated Circuit Device Family*. Go to <http://www.freescale.com/lf> and search for AN1977 or AN1987.

Table 1. Maximum Ratings

Rating	Symbol	Value	Unit
Drain-Source Voltage	V_{DSS}	-0.5, +65	Vdc
Gate-Source Voltage	V_{GS}	-6.0, +10	Vdc
Operating Voltage	V_{DD}	32, +0	Vdc
Storage Temperature Range	T_{stg}	-65 to +150	°C
Case Operating Temperature Range	T_C	-40 to +150	°C
Operating Junction Temperature Range (1,2)	T_J	-40 to +225	°C
Input Power	P_{in}	20	dBm

Table 2. Thermal Characteristics

Characteristic	Symbol	Value (2,3)	Unit
Thermal Resistance, Junction to Case	$R_{\theta JC}$	5.5	°C/W
Case Temperature 80°C, 3.2 W CW, 940 MHz			
Stage 1, 28 Vdc, $I_{DQ1} = 106$ mA		1.6	
Stage 2, 28 Vdc, $I_{DQ2} = 285$ mA			
Case Temperature 80°C, 30 W CW, 940 MHz		5.8	
Stage 1, 28 Vdc, $I_{DQ1} = 40$ mA		1.2	
Stage 2, 28 Vdc, $I_{DQ2} = 340$ mA			

Table 3. ESD Protection Characteristics

Test Methodology	Class
Human Body Model (per JESD22-A114)	1B, passes 500 V
Machine Model (per EIA/JESD22-A115)	A, passes 100 V
Charge Device Model (per JESD22-C101)	II, passes 200 V

Table 4. Moisture Sensitivity Level

Test Methodology	Rating	Package Peak Temperature	Unit
Per JESD22-A113, IPC/JEDEC J-STD-020	3	260	°C

Table 5. Electrical Characteristics ($T_A = 25^\circ\text{C}$ unless otherwise noted)

Characteristic	Symbol	Min	Typ	Max	Unit
----------------	--------	-----	-----	-----	------

Stage 1 — Off Characteristics

Zero Gate Voltage Drain Leakage Current ($V_{DS} = 65$ Vdc, $V_{GS} = 0$ Vdc)	I_{DSS}	—	—	10	μA_{dc}
Zero Gate Voltage Drain Leakage Current ($V_{DS} = 28$ Vdc, $V_{GS} = 0$ Vdc)	I_{DSS}	—	—	1	μA_{dc}
Gate-Source Leakage Current ($V_{GS} = 1.5$ Vdc, $V_{DS} = 0$ Vdc)	I_{GSS}	—	—	1	μA_{dc}

Stage 1 — On Characteristics

Gate Threshold Voltage ($V_{DS} = 10$ Vdc, $I_D = 14$ μA_{dc})	$V_{GS(th)}$	1.2	2	2.7	Vdc
Gate Quiescent Voltage ($V_{DS} = 28$ Vdc, $I_{DQ1} = 106$ mA)	$V_{GS(Q)}$	—	2.8	—	Vdc
Fixture Gate Quiescent Voltage (4) ($V_{DD} = 28$ Vdc, $I_{DQ1} = 106$ mA, Measured in Functional Test)	$V_{GG(Q)}$	6.9	9.4	11.9	Vdc

1. Continuous use at maximum temperature will affect MTTF.
2. MTTF calculator available at <http://www.freescale.com/rf/calculators>.
3. Refer to [AN1955](#), *Thermal Measurement Methodology of RF Power Amplifiers*. Go to <http://www.freescale.com/rf> and search for AN1955.
4. $V_{GG} = 3.3 \times V_{GS(Q)}$. Parameter measured on Freescale test fixture, due to resistor divider network on the board. Refer to test circuit schematic.

(continued)

Table 5. Electrical Characteristics ($T_A = 25^\circ\text{C}$ unless otherwise noted) (continued)

Characteristic	Symbol	Min	Typ	Max	Unit
Stage 2 — Off Characteristics					
Zero Gate Voltage Drain Leakage Current ($V_{DS} = 65\text{ Vdc}$, $V_{GS} = 0\text{ Vdc}$)	I_{DSS}	—	—	10	$\mu\text{A dc}$
Zero Gate Voltage Drain Leakage Current ($V_{DS} = 28\text{ Vdc}$, $V_{GS} = 0\text{ Vdc}$)	I_{DSS}	—	—	1	$\mu\text{A dc}$
Gate-Source Leakage Current ($V_{GS} = 1.5\text{ Vdc}$, $V_{DS} = 0\text{ Vdc}$)	I_{GSS}	—	—	1	$\mu\text{A dc}$

Stage 2 — On Characteristics

Gate Threshold Voltage ($V_{DS} = 10\text{ Vdc}$, $I_D = 74\ \mu\text{A dc}$)	$V_{GS(th)}$	1.2	2	2.7	Vdc
Gate Quiescent Voltage ($V_{DS} = 28\text{ Vdc}$, $I_{DQ2} = 285\text{ mA}$)	$V_{GS(Q)}$	—	2.6	—	Vdc
Fixture Gate Quiescent Voltage ⁽¹⁾ ($V_{DD} = 28\text{ Vdc}$, $I_{DQ2} = 285\text{ mA}$, Measured in Functional Test)	$V_{GG(Q)}$	4.2	5.9	7.6	Vdc
Drain-Source On-Voltage ($V_{GS} = 10\text{ Vdc}$, $I_D = 740\text{ mA}$)	$V_{DS(on)}$	0.1	0.3	0.8	Vdc

Functional Tests ^(2,3) (In Freescale Test Fixture, 50 ohm system) $V_{DD} = 28\text{ Vdc}$, $I_{DQ1} = 106\text{ mA}$, $I_{DQ2} = 285\text{ mA}$, $P_{out} = 3.2\text{ W Avg.}$, $f = 940\text{ MHz}$, Single-Carrier W-CDMA, 3.84 MHz Channel Bandwidth Carrier, IQ Magnitude Clipping, Input Signal PAR = 7.5 dB @ 0.01% Probability on CCDF. ACPR measured in 3.84 MHz Channel Bandwidth @ $\pm 5\text{ MHz}$ Offset.

Power Gain	G_{ps}	33	35.9	38	dB
Power Added Efficiency	PAE	14	16.5	—	%
Adjacent Channel Power Ratio	ACPR	—	-49.5	-46	dBc
Input Return Loss	IRL	—	-18.7	-9	dB

Typical Performance — 900 MHz (In Freescale 900 MHz Application Test Fixture, 50 ohm system) $V_{DD} = 28\text{ Vdc}$, $I_{DQ1} = 106\text{ mA}$, $I_{DQ2} = 285\text{ mA}$, 920–960 MHz Bandwidth

$V_{DD} = 28\text{ Vdc}$, $I_{DQ1} = 40\text{ mA}$, $I_{DQ2} = 340\text{ mA}$ P_{out} @ 1 dB Compression Point, CW	P1dB	—	31	—	W
IMD Symmetry @ 25 W PEP, P_{out} where IMD Third Order Intermodulation $\cong 30\text{ dBc}$ (Delta IMD Third Order Intermodulation between Upper and Lower Sidebands > 2 dB)	IMD _{sym}	—	45	—	MHz
VBW Resonance Point (IMD Third Order Intermodulation Inflection Point)	VBW _{res}	—	80	—	MHz
Quiescent Current Accuracy over Temperature ⁽⁴⁾ with 3 k Ω Gate Feed Resistors (-30 to 85°C)	ΔI_{QT}	—	0.02	—	%
Gain Flatness in 40 MHz Bandwidth @ $P_{out} = 3.2\text{ W Avg.}$	G_F	—	0.2	—	dB
Gain Variation over Temperature (-30°C to +85°C)	ΔG	—	0.036	—	dB/°C
Output Power Variation over Temperature (-30°C to +85°C)	ΔP_{1dB}	—	0.01	—	dBm/°C

Table 6. Ordering Information

Device	Tape and Reel Information	Package
MMRF2005NR1	R1 Suffix = 500 Units, 44 mm Tape Width, 13-inch Reel	TO-270WB-16
MMRF2005GMR1		TO-270WBG-16

- $V_{GG} = 2.25 \times V_{GS(Q)}$. Parameter measured on Freescale test fixture, due to resistor divider network on the board. Refer to test circuit schematic.
- Part internally matched both on input and output.
- Measurements made with device in straight lead configuration before any lead forming operation is applied. Lead forming is used for gull wing (GN) parts.
- Refer to [AN1977](#), *Quiescent Current Thermal Tracking Circuit in the RF Integrated Circuit Family*, and to [AN1987](#), *Quiescent Current Control for the RF Integrated Circuit Device Family*. Go to <http://www.freescale.com/rf> and search for AN1977 or AN1987.

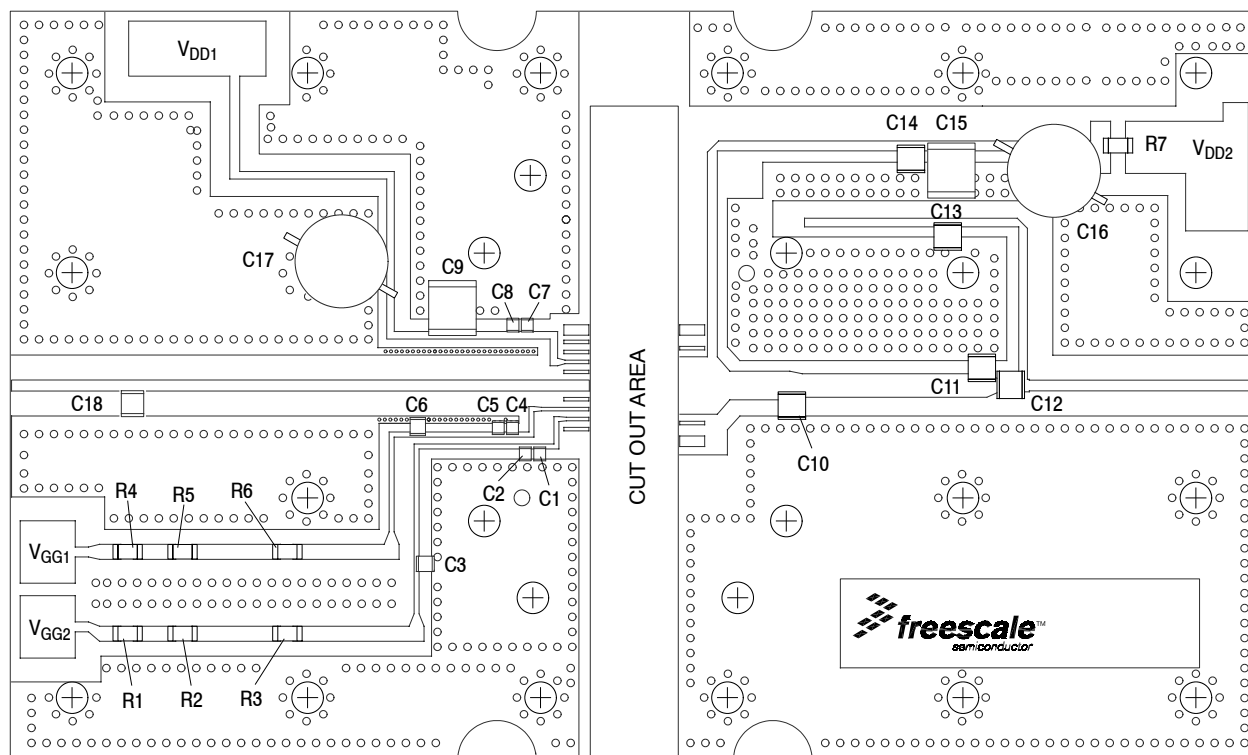

Figure 3. MMRF2005N Test Circuit Component Layout — 900 MHz

Table 7. MMRF2005N Test Circuit Component Designations and Values — 900 MHz

Part	Description	Part Number	Manufacturer
C1, C4, C7	47 pF Chip Capacitors	ATC600F470JT250XT	ATC
C2, C5, C8	10 nF, 50 V Chip Capacitors	C0603C103J5RAC-TU	Kemet
C3, C6	1 μ F, 50 V Chip Capacitors	GRM21BR71H105KA12L	Murata
C9, C15	10 μ F, 50 V Chip Capacitors	GRM55DR61H106KA88L	Murata
C10	16 pF Chip Capacitor	ATC100B160JT500XT	ATC
C11	6.2 pF Chip Capacitor	ATC100B6R2BT500XT	ATC
C12	7.5 pF Chip Capacitor	ATC100B7R5CT500XT	ATC
C13, C14	47 pF Chip Capacitors	ATC100B470JT500XT	ATC
C16, C17	100 μ F, 50 V Electrolytic Capacitors	MCGPR35V337M10X16-RH	Multicomp
C18	0.5 pF Chip Capacitor	ATC100B0R5BT500XT	ATC
R1, R2, R3, R4, R5, R6	1000 Ω , 1/4 W Chip Resistors	CRCW12061K00FKEA	Vishay
R7	0 Ω , 3A Chip Resistor	CRCW12060000Z0EA	Vishay
PCB	0.020", $\epsilon_r = 3.5$	RF-35	Taconic

TYPICAL CHARACTERISTICS — 900 MHz

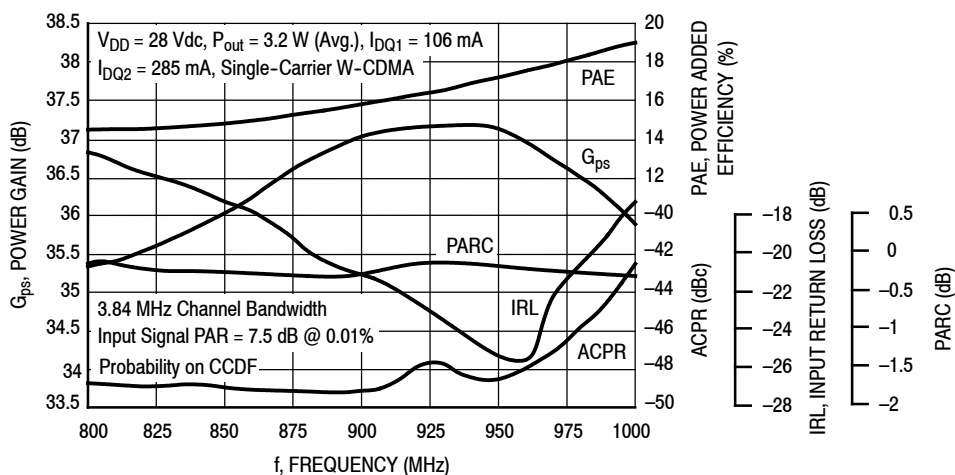

Figure 4. Output Peak-to-Average Ratio Compression (PARC) Broadband Performance @ $P_{out} = 3.2$ Watts Avg.

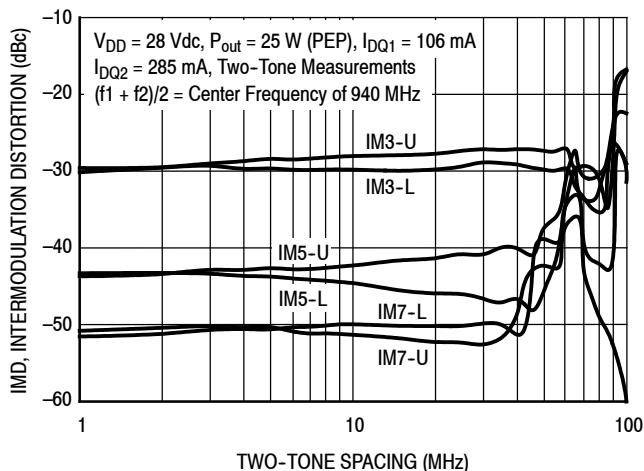

Figure 5. Intermodulation Distortion Products versus Two-Tone Spacing

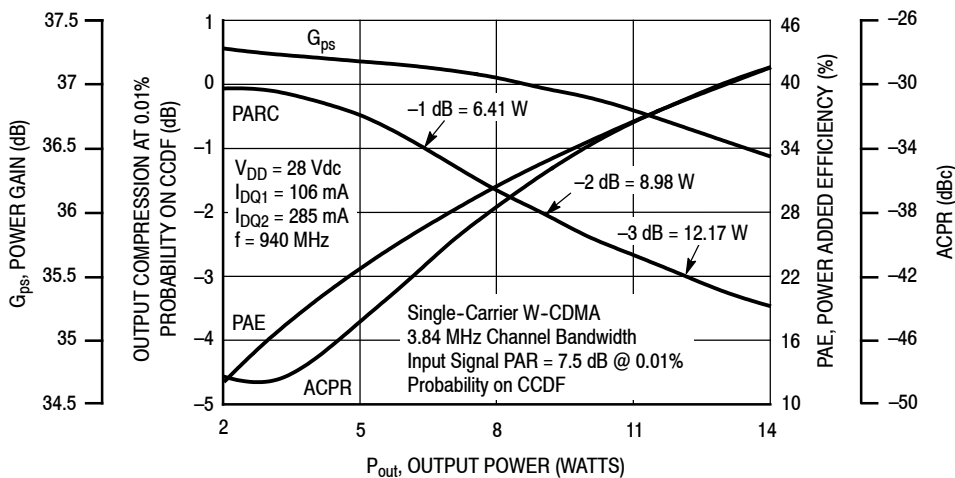

Figure 6. Output Peak-to-Average Ratio Compression (PARC) versus Output Power

TYPICAL CHARACTERISTICS — 900 MHz

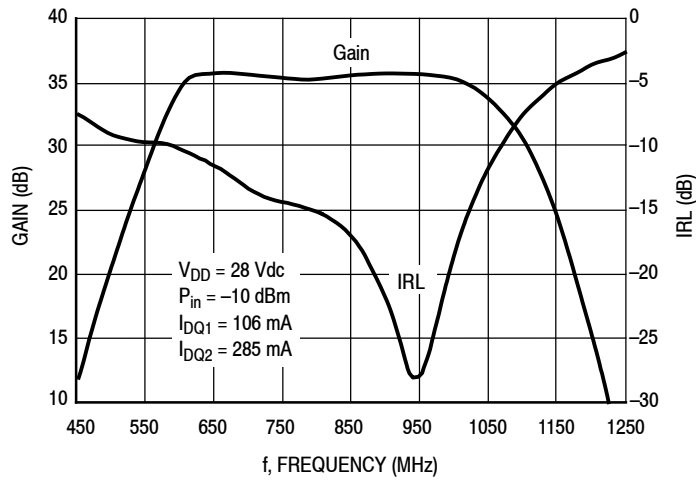

Figure 7. Broadband Frequency Response

Table 8. Series Equivalent Input and Load Impedance — 900 MHz

f MHz	Z_{in} Ω	Z_{load} Ω
820	$37.95 + j2.31$	$4.70 + j0.98$
840	$39.95 + j2.72$	$4.29 + j1.23$
860	$42.70 + j1.02$	$3.93 + j1.67$
880	$44.40 - j1.38$	$3.63 + j2.15$
900	$46.25 - j4.92$	$3.41 + j2.61$
920	$45.70 - j8.41$	$3.14 + j3.05$
940	$45.46 - j11.47$	$2.94 + j3.48$
960	$45.07 - j15.19$	$2.85 + j3.90$
980	$43.49 - j18.03$	$2.69 + j4.32$

Z_{in} = Device input impedance as measured from gate to ground.

Z_{load} = Test circuit impedance as measured from drain to ground.

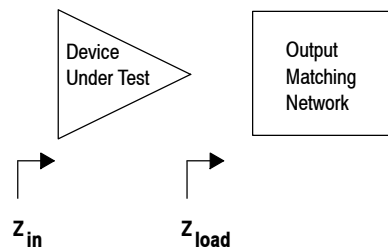

LOAD PULL CHARACTERISTICS — 900 MHz

Table 9. Load Pull Performance $V_{DD} = 28$ Vdc,
 $I_{DQ1} = 106$ mA, $I_{DQ2} = 285$ mA, Pulsed CW, 10 μ sec(on), 10% Duty Cycle

f (MHz)	P1dB		P3dB	
	Watts	dBm	Watts	dBm
920	43	46.3	51	47.1
940	42	46.3	50	47
960	42	46.3	50	47

NOTE: Load Pull Test Fixture Tuned for Peak P1dB Output Power @ 28 V

Test Impedances per Compression Level

f (MHz)		Z_{source} Ω	Z_{load} Ω
920	P1dB	55.82 + j15.71	4.54 + j1.15
940	P1dB	52.56 + j20.20	4.38 + j1.21
960	P1dB	49.18 + j25.00	5.04 + j1.15

900 MHz APPLICATION CIRCUIT

Table 10. 900 MHz Performance (In Freescale Application Circuit, 50 ohm system) $V_{DD} = 28$ Vdc, $I_{DQ1} = 106$ mA, $I_{DQ2} = 285$ mA, $P_{out} = 3.2$ W Avg., Channel Bandwidth = 3.84 MHz, Input Signal PAR = 7.5 dB @ 0.01% Probability on CCDF

Frequency (MHz)	G_{ps} (dB)	PAE (%)	ACPR (dBc)
920	36.6	16.1	-48.0
940	36.8	16.7	-48.7
960	36.6	17.3	-48.6

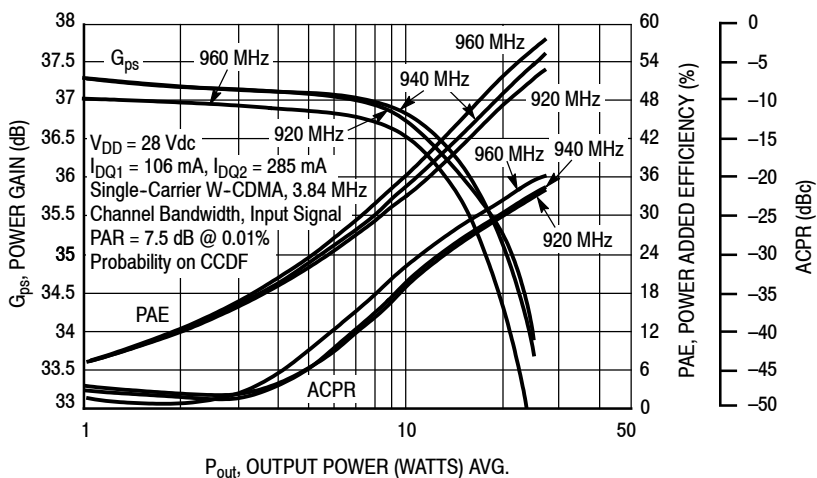

Figure 8. Single-Carrier W-CDMA Power Gain, Power Added Efficiency and ACPR versus Output Power

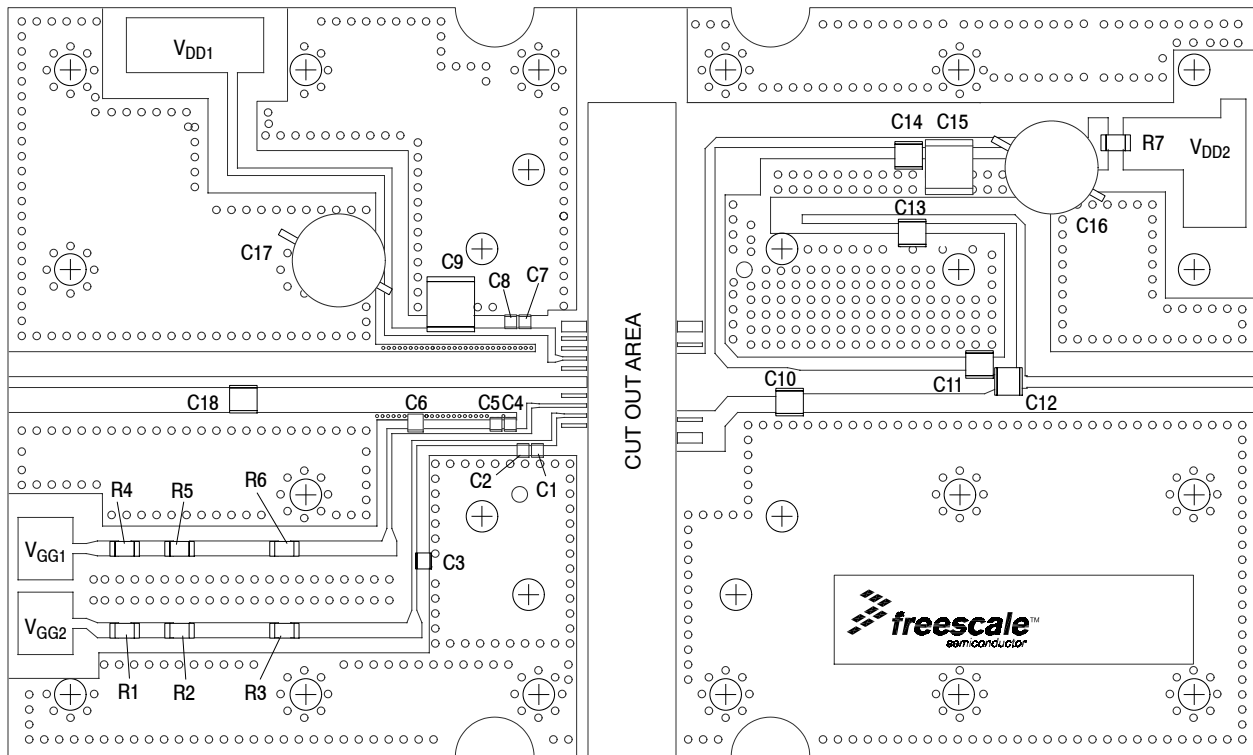

Figure 9. MMRF2005N Test Circuit Component Layout — 700 MHz

Table 11. MMRF2005N Test Circuit Component Designations and Values — 700 MHz

Part	Description	Part Number	Manufacturer
C1, C4, C7	47 pF Chip Capacitors	ATC600F470JT250XT	ATC
C2, C5, C8	10 nF, 50 V Chip Capacitors	C0603C103J5RAC	Kemet
C3, C6	1 μ F, 50 V Chip Capacitors	GRM21BR71H105KA12L	Murata
C9, C15	10 μ F, 50 V Chip Capacitors	GRM55DR61H106KA88L	Murata
C10	13 pF Chip Capacitor	ATC100B130JT500XT	ATC
C11	7.5 pF Chip Capacitor	ATC100B7R5CT500XT	ATC
C12	6.8 pF Chip Capacitor	ATC100B6R8CT500XT	ATC
C13, C14	47 pF Chip Capacitors	ATC100B470JT500XT	ATC
C16, C17	100 μ F, 50 V Electrolytic Capacitors	MCGPR35V337M10X16-RH	Multicomp
C18	1.8 pF Chip Capacitor	ATC100B1R8BT500XT	ATC
R1, R2, R3, R4, R5, R6	1000 Ω , 1/4 W Chip Resistors	CRCW12061K00FKEA	Vishay
R7	0 Ω , 3A Chip Resistor	CRCW12060000Z0EA	Vishay
PCB	0.020", $\epsilon_r = 3.5$	RF-35	Taconic

TYPICAL CHARACTERISTICS — 700 MHz

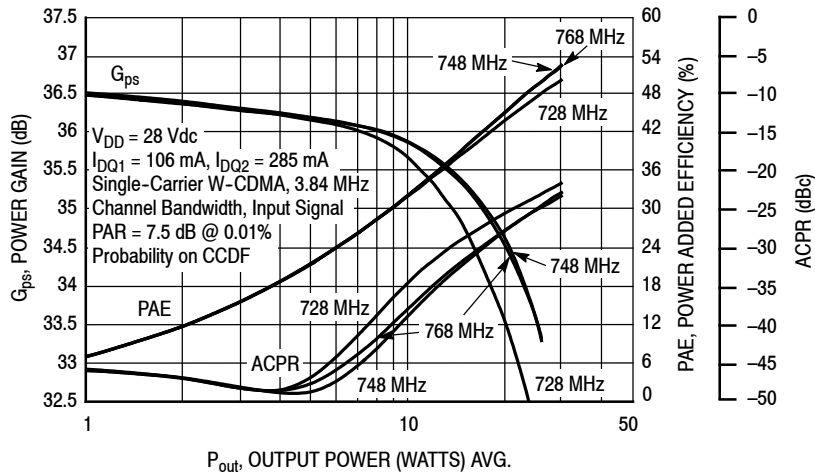

Figure 10. Single-Carrier W-CDMA Power Gain, Power Added Efficiency and ACPR versus Output Power — 700 MHz

Table 12. Series Equivalent Input and Load Impedance — 700 MHz

f MHz	Z _{in} Ω	Z _{load} Ω
710	25.21 - j1.21	8.57 + j2.52
720	33.76 + j5.36	8.52 + j2.46
730	38.78 + j1.40	8.44 + j2.34
740	40.14 - j0.76	8.36 + j2.16
750	35.46 - j1.15	8.30 + j2.00
760	34.65 - j0.53	8.32 + j1.90
770	34.75 - j0.43	8.31 + j1.86
780	36.20 + j0.81	8.27 + j1.98
790	36.18 + j1.33	8.23 + j2.12

Z_{in} = Device input impedance as measured from gate to ground.

Z_{load} = Test circuit impedance as measured from drain to ground.

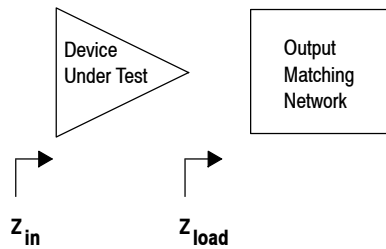

PACKAGE DIMENSIONS

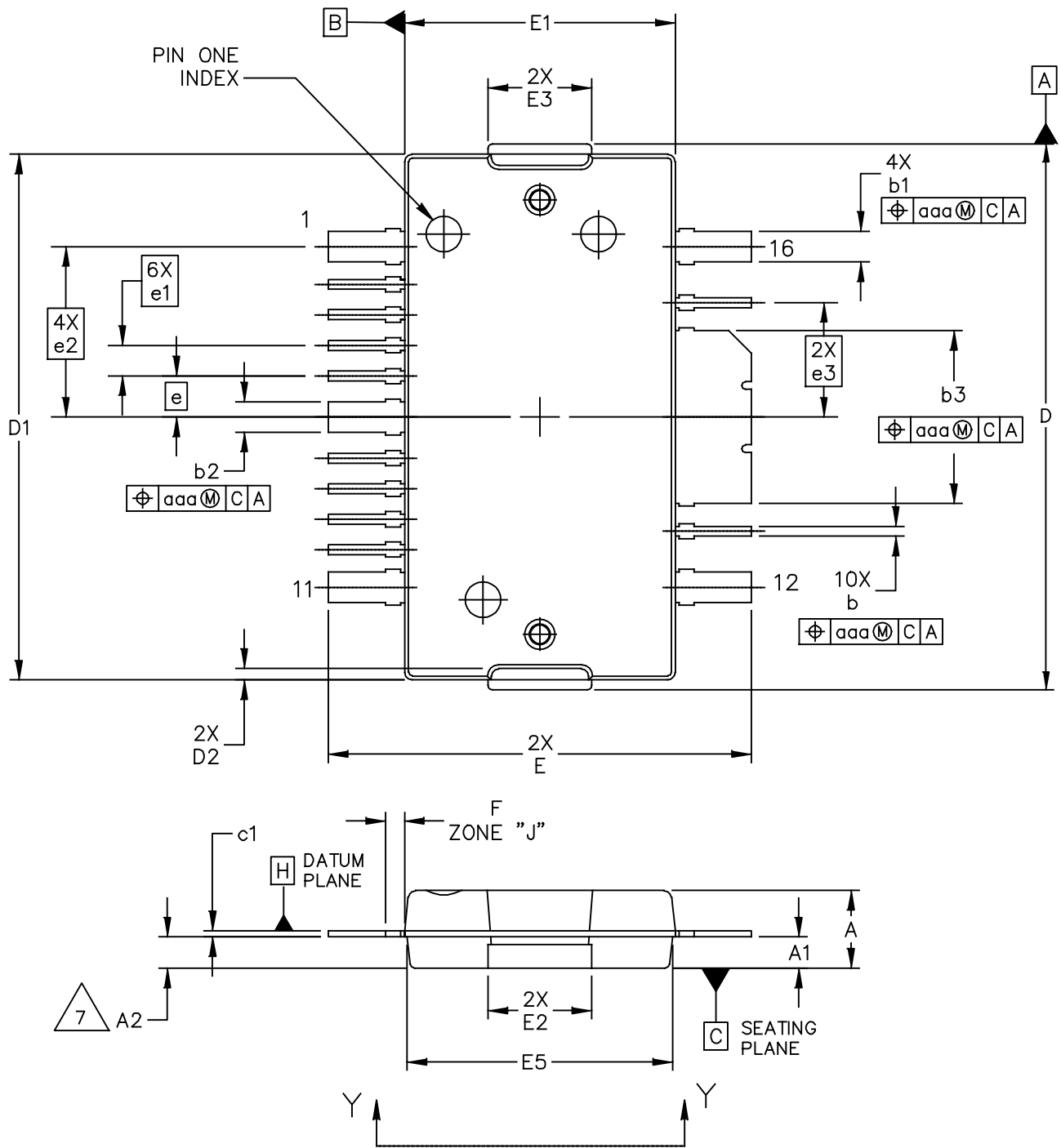

© FREESCALE SEMICONDUCTOR, INC. ALL RIGHTS RESERVED.		MECHANICAL OUTLINE		PRINT VERSION NOT TO SCALE	
TITLE: TO-270 WIDE BODY 16 LEAD		DOCUMENT NO: 98ASA10754D		REV: A	
		CASE NUMBER: 1886-01		31 AUG 2007	
		STANDARD: NON-JEDEC			

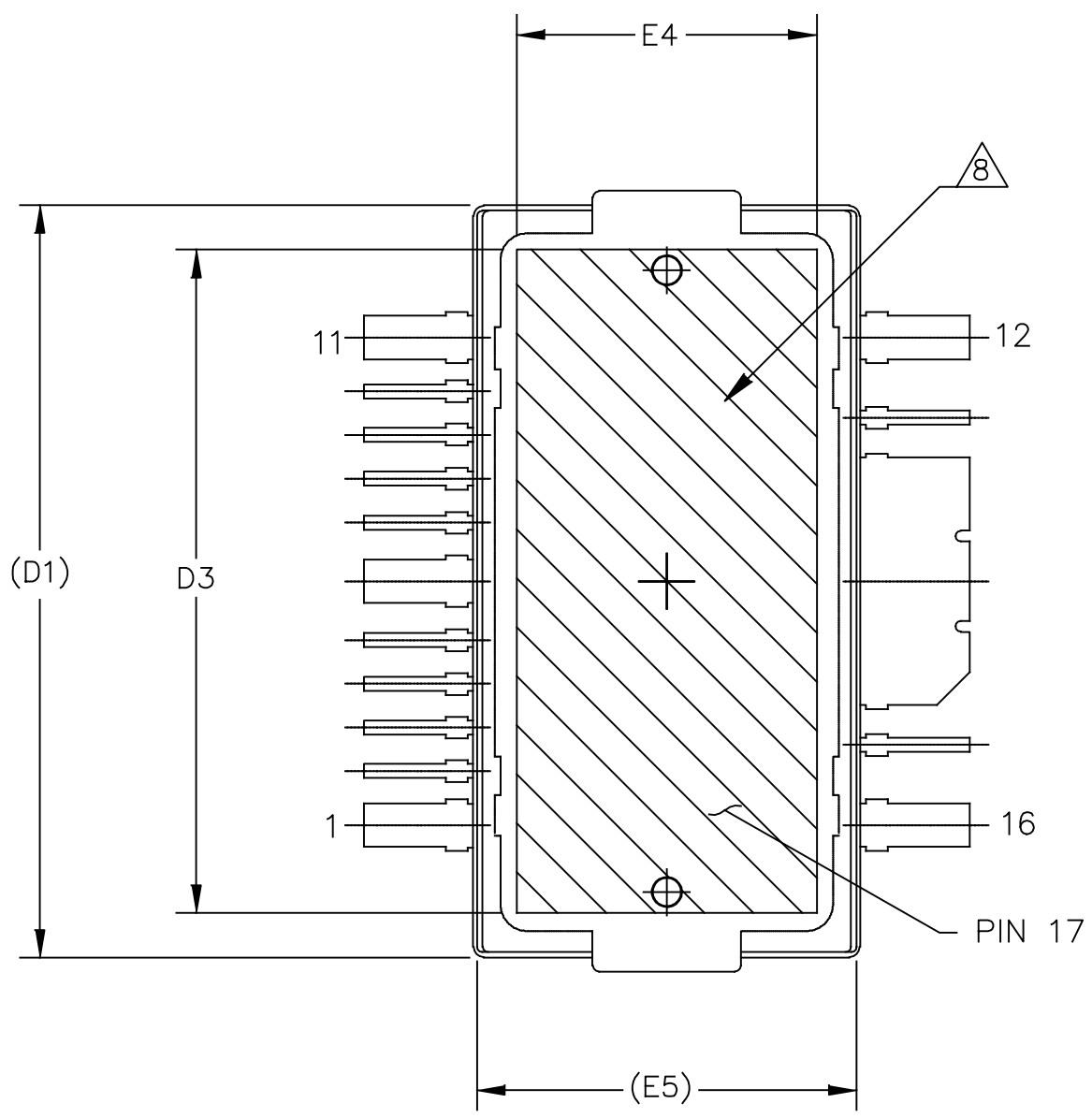

VIEW Y-Y

© FREESCALE SEMICONDUCTOR, INC. ALL RIGHTS RESERVED.	MECHANICAL OUTLINE	PRINT VERSION NOT TO SCALE	
TITLE: TO-270 WIDE BODY 16 LEAD	DOCUMENT NO: 98ASA10754D	REV: A	
	CASE NUMBER: 1886-01	31 AUG 2007	
	STANDARD: NON-JEDEC		

NOTES:

1. CONTROLLING DIMENSION: INCH
2. INTERPRET DIMENSIONS AND TOLERANCES PER ASME Y14.5M-1994.
3. DATUM PLANE -H- IS LOCATED AT THE TOP OF LEAD AND IS COINCIDENT WITH THE LEAD WHERE THE LEAD EXITS THE PLASTIC BODY AT THE TOP OF THE PARTING LINE.
4. DIMENSIONS "D" AND "E1" DO NOT INCLUDE MOLD PROTRUSION. ALLOWABLE PROTRUSION IS .006 (0.15) PER SIDE. DIMENSIONS "D" AND "E1" DO INCLUDE MOLD MISMATCH AND ARE DETERMINED AT DATUM PLANE -H-.
5. DIMENSIONS "b", "b1", "b2" AND "b3" DO NOT INCLUDE DAMBAR PROTRUSION. ALLOWABLE DAMBAR PROTRUSION SHALL BE .005 (0.13) TOTAL IN EXCESS OF THE "b", "b1", "b2" AND "b3" DIMENSIONS AT MAXIMUM MATERIAL CONDITION.
6. DATUM -A- AND -B- TO BE DETERMINED AT DATUM PLANE -H-.
7. DIMENSION A2 APPLIES WITHIN ZONE "J" ONLY.
8. HATCHING REPRESENTS THE EXPOSED AREA OF THE HEAT SLUG. HATCHED AREA SHOWN IS ON THE SAME PLANE.

DIM	INCH		MILLIMETER		DIM	INCH		MILLIMETER	
	MIN	MAX	MIN	MAX		MIN	MAX	MIN	MAX
A	.100	.104	2.54	2.64	F	.025 BSC		0.64 BSC	
A1	.039	.043	0.99	1.09	b	.011	.017	0.28	0.43
A2	.040	.042	1.02	1.07	b1	.037	.043	0.94	1.09
D	.712	.720	18.08	18.29	b2	.037	.043	0.94	1.09
D1	.688	.692	17.48	17.58	b3	.225	.231	5.72	5.87
D2	.011	.019	0.28	0.48	c1	.007	.011	.18	.28
D3	.600	---	15.24	---	e	.054 BSC		1.37 BSC	
E	.551	.559	14	14.2	e1	.040 BSC		1.02 BSC	
E1	.353	.357	8.97	9.07	e2	.224 BSC		5.69 BSC	
E2	.132	.140	3.35	3.56	e3	.150 BSC		3.81 BSC	
E3	.124	.132	3.15	3.35	aaa	.004		.10	
E4	.270	---	6.86	---					
E5	.346	.350	8.79	8.89					
© FREESCALE SEMICONDUCTOR, INC. ALL RIGHTS RESERVED.			MECHANICAL OUTLINE			PRINT VERSION NOT TO SCALE			
TITLE: TO-270 WIDE BODY 16 LEAD					DOCUMENT NO: 98ASA10754D			REV: A	
					CASE NUMBER: 1886-01			31 AUG 2007	
					STANDARD: NON-JEDEC				

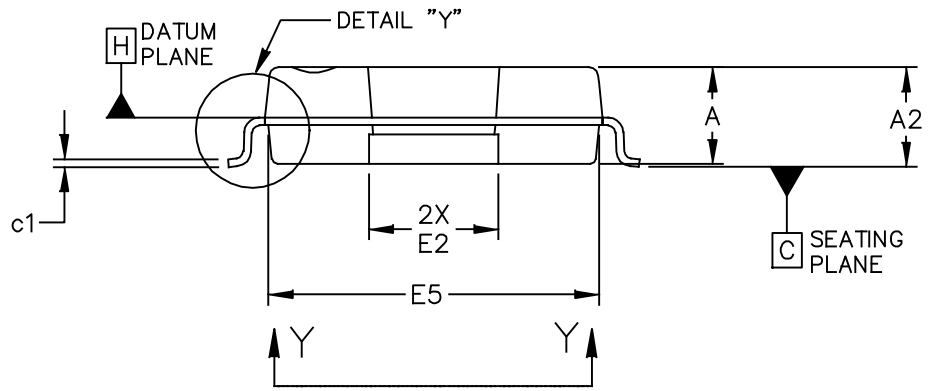
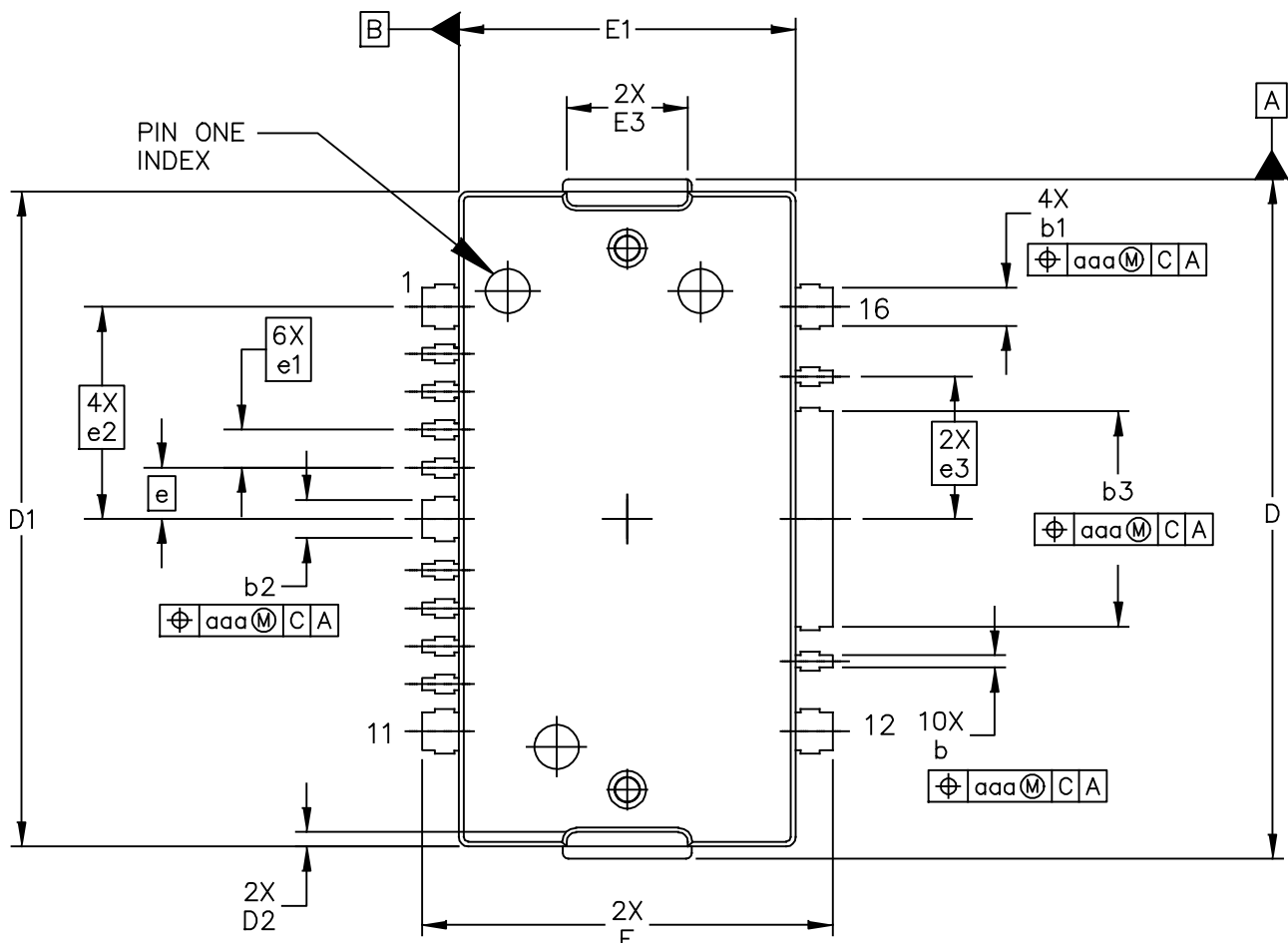

© FREESCALE SEMICONDUCTOR, INC. ALL RIGHTS RESERVED.		MECHANICAL OUTLINE		PRINT VERSION NOT TO SCALE	
TITLE: TO-270 WIDE BODY 16 LEAD, GULL WING		DOCUMENT NO: 98ASA10755D		REV: A	
		CASE NUMBER: 1887-01		31 AUG 2007	
		STANDARD: NON-JEDEC			

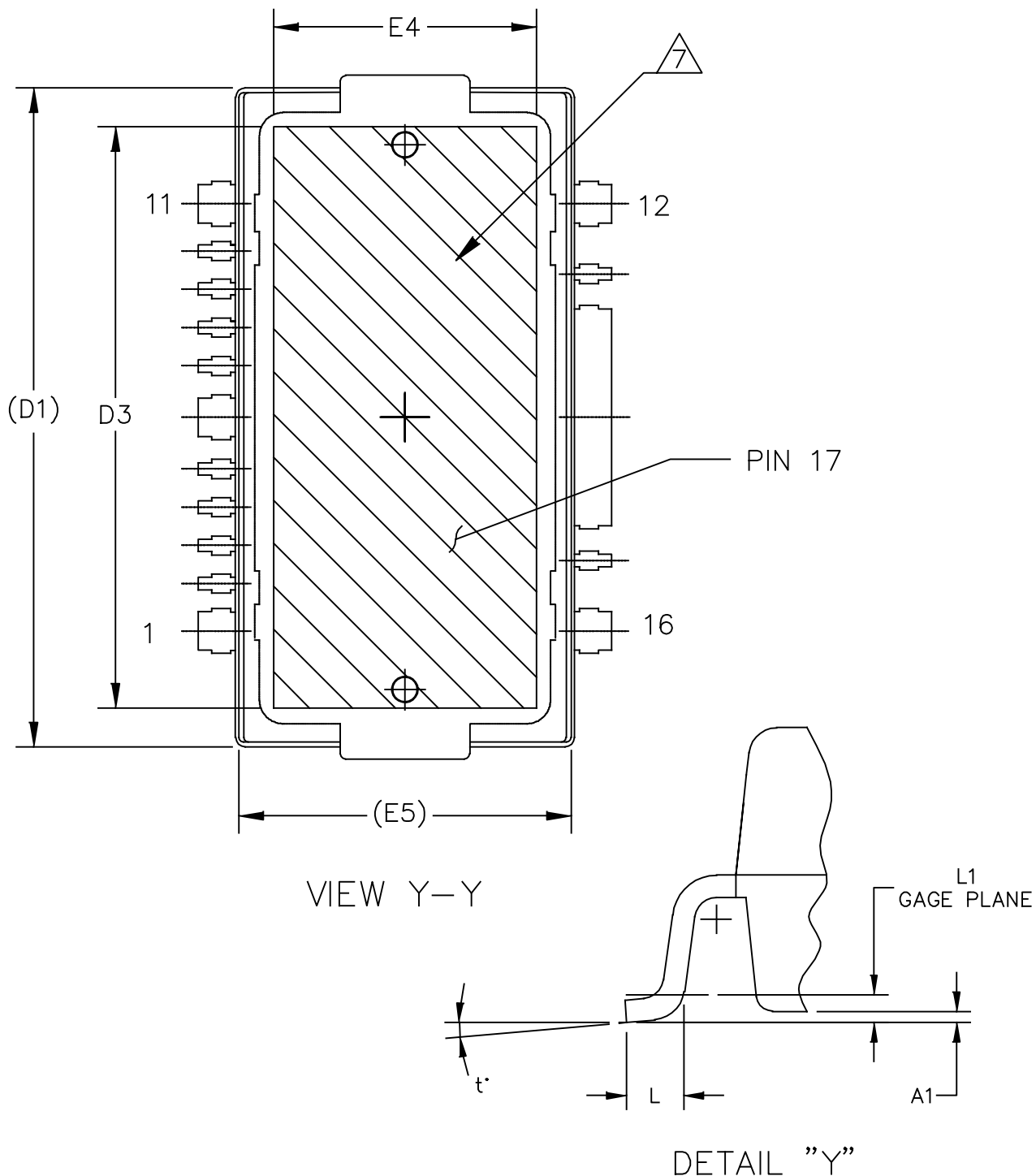

© FREESCALE SEMICONDUCTOR, INC. ALL RIGHTS RESERVED.		MECHANICAL OUTLINE		PRINT VERSION NOT TO SCALE	
TITLE: TO-270 WIDE BODY 16 LEAD, GULL WING	DOCUMENT NO: 98ASA10755D		REV: A		
	CASE NUMBER: 1887-01		31 AUG 2007		
	STANDARD: NON-JEDEC				

NOTES:

1. CONTROLLING DIMENSION: INCH
2. INTERPRET DIMENSIONS AND TOLERANCES PER ASME Y14.5M-1994.
3. DATUM PLANE -H- IS LOCATED AT THE TOP OF LEAD AND IS COINCIDENT WITH THE LEAD WHERE THE LEAD EXITS THE PLASTIC BODY AT THE TOP OF THE PARTING LINE.
4. DIMENSIONS "D" AND "E1" DO NOT INCLUDE MOLD PROTRUSION. ALLOWABLE PROTRUSION IS .006 (0.15) PER SIDE. DIMENSIONS "D" AND "E1" DO INCLUDE MOLD MISMATCH AND ARE DETERMINED AT DATUM PLANE -H-.
5. DIMENSIONS "b", "b1", "b2" AND "b3" DO NOT INCLUDE DAMBAR PROTRUSION. ALLOWABLE DAMBAR PROTRUSION SHALL BE .005 (0.13) TOTAL IN EXCESS OF THE "b", "b1", "b2" AND "b3" DIMENSIONS AT MAXIMUM MATERIAL CONDITION.
6. DATUM -A- AND -B- TO BE DETERMINED AT DATUM PLANE -H-.
7. HATCHING REPRESENTS EXPOSED AREA OF THE HEAT SLUG. HATCHED AREA SHOWN IS ON THE SAME PLANE.

DIM	INCH		MILLIMETER		DIM	INCH		MILLIMETER	
	MIN	MAX	MIN	MAX		MIN	MAX	MIN	MAX
A	.100	.104	2.54	2.64	L	.018	.024	0.46	0.61
A1	.001	.004	0.02	0.10	L1	.010 BSC		0.25 BSC	
A2	.099	.110	2.51	2.79	b	.011	.017	0.28	0.43
D	.712	.720	18.08	18.29	b1	.037	.043	0.94	1.09
D1	.688	.692	17.48	17.58	b2	.037	.043	0.94	1.09
D2	.011	.019	0.28	0.48	b3	.225	.231	5.72	5.87
D3	.600	---	15.24	---	c1	.007	.011	0.18	0.28
E	.429	.437	10.9	11.1	e	.054 BSC		1.37 BSC	
E1	.353	.357	8.97	9.07	e1	.040 BSC		1.02 BSC	
E2	.132	.140	3.35	3.56	e2	.224 BSC		5.69 BSC	
E3	.124	.132	3.15	3.35	e3	.150 BSC		3.81 BSC	
E4	.270	---	6.86	---	t	2'	8'	2'	8'
E5	.346	.350	8.79	8.89	aaa	.004		0.10	
© FREESCALE SEMICONDUCTOR, INC. ALL RIGHTS RESERVED.			MECHANICAL OUTLINE			PRINT VERSION NOT TO SCALE			
TITLE: TO-270 WIDE BODY 16 LEAD, GULL WING					DOCUMENT NO: 98ASA10755D			REV: A	
					CASE NUMBER: 1887-01			31 AUG 2007	
					STANDARD: NON-JEDEC				

PRODUCT DOCUMENTATION AND SOFTWARE

Refer to the following resources to aid your design process.

Application Notes

- AN1907: Solder Reflow Attach Method for High Power RF Devices in Plastic Packages
- AN1955: Thermal Measurement Methodology of RF Power Amplifiers
- AN1977: Quiescent Current Thermal Tracking Circuit in the RF Integrated Circuit Family
- AN1987: Quiescent Current Control for the RF Integrated Circuit Device Family
- AN3789: Clamping of High Power RF Transistors and RFICs in Over-Molded Plastic Packages

Engineering Bulletins

- EB212: Using Data Sheet Impedances for RF LDMOS Devices

Software

- Electromigration MTTF Calculator

To Download Resources Specific to a Given Part Number:

1. Go to <http://www.freescale.com/rf>
2. Search by part number
3. Click part number link
4. Choose the desired resource from the drop down menu

REVISION HISTORY

The following table summarizes revisions to this document.

Revision	Date	Description
0	Aug. 2015	• Initial Release of Data Sheet

How to Reach Us:

Home Page:
freescale.com

Web Support:
freescale.com/support

Information in this document is provided solely to enable system and software implementers to use Freescale products. There are no express or implied copyright licenses granted hereunder to design or fabricate any integrated circuits based on the information in this document.

Freescale reserves the right to make changes without further notice to any products herein. Freescale makes no warranty, representation, or guarantee regarding the suitability of its products for any particular purpose, nor does Freescale assume any liability arising out of the application or use of any product or circuit, and specifically disclaims any and all liability, including without limitation consequential or incidental damages. "Typical" parameters that may be provided in Freescale data sheets and/or specifications can and do vary in different applications, and actual performance may vary over time. All operating parameters, including "typicals," must be validated for each customer application by customer's technical experts. Freescale does not convey any license under its patent rights nor the rights of others. Freescale sells products pursuant to standard terms and conditions of sale, which can be found at the following address: freescale.com/SalesTermsandConditions.

Freescale and the Freescale logo are trademarks of Freescale Semiconductor, Inc., Reg. U.S. Pat. & Tm. Off. All other product or service names are the property of their respective owners.

© 2015 Freescale Semiconductor, Inc.



Компания «ЭлектроПласт» предлагает заключение долгосрочных отношений при поставках импортных электронных компонентов на взаимовыгодных условиях!

Наши преимущества:

- Оперативные поставки широкого спектра электронных компонентов отечественного и импортного производства напрямую от производителей и с крупнейших мировых складов;
- Поставка более 17-ти миллионов наименований электронных компонентов;
- Поставка сложных, дефицитных, либо снятых с производства позиций;
- Оперативные сроки поставки под заказ (от 5 рабочих дней);
- Экспресс доставка в любую точку России;
- Техническая поддержка проекта, помощь в подборе аналогов, поставка прототипов;
- Система менеджмента качества сертифицирована по Международному стандарту ISO 9001;
- Лицензия ФСБ на осуществление работ с использованием сведений, составляющих государственную тайну;
- Поставка специализированных компонентов (Xilinx, Altera, Analog Devices, Intersil, Interpoint, Microsemi, Aeroflex, Peregrine, Syfer, Eurofarad, Texas Instrument, Miteq, Cobham, E2V, MA-COM, Hittite, Mini-Circuits, General Dynamics и др.);

Помимо этого, одним из направлений компании «ЭлектроПласт» является направление «Источники питания». Мы предлагаем Вам помощь Конструкторского отдела:

- Подбор оптимального решения, техническое обоснование при выборе компонента;
- Подбор аналогов;
- Консультации по применению компонента;
- Поставка образцов и прототипов;
- Техническая поддержка проекта;
- Защита от снятия компонента с производства.



Как с нами связаться

Телефон: 8 (812) 309 58 32 (многоканальный)

Факс: 8 (812) 320-02-42

Электронная почта: org@eplast1.ru

Адрес: 198099, г. Санкт-Петербург, ул. Калинина, дом 2, корпус 4, литера А.