

General-purpose CMOS Logic IC Series (BU4S,BU4000B Series)

High Voltage CMOS Logic ICs <Analog Switch>



**BU4066BC, BU4066BCF, BU4066BCFV, BU4051BC,
BU4051BCF, BU4051BCFV, BU4052BC, BU4052BCF, BU4052BCFV,
BU4053BC, BU4053BCF, BU4053BCFV, BU4551B, BU4551BF, BU4551BFV**

No.13050ECT05

●Description

BU4066BC series ICs each contain 4 independent switches capable of controlling either digital or analog signals. BU4051BC / BU4052BC / BU4053BC / and BU4551B series ICs are analog selectable composite multiplexer/demultiplexer. BU4051BC series is configured with 8 channels, BU4052BC is configured with two 4 channels, BU4053BC series is configured with three 2 channels, BU4551B series is configured with four 2 channels, and switches applicable for each channel are turned on according to digital signals of control terminal. Even if the logic amplitude (VDD-VSS) of the control signal is small, signals of large amplitude (VDD-VEE) can be switched.

●Features

- 1) Low power consumption
- 2) Wide operating supply voltage (3[V]~18[V])
- 3) High input impedance
- 4) L-TTL2 input and LS-TTL1 can be driven directly.
- 5) Applicable channel switches can be turned "ON" and "OFF" by the digital control signal.
- 6) Small control voltage (VDD-VSS) can control signals of large amplitude (VDD-VEE).
- 7) Linearity with excellent transfer characteristics

●Use

This product is used as the switch and chopper modulation circuit of analog and digital signals. Since ON resistance of each switch is low, the product can be connected to low impedance circuit. The product can be used as ON/OFF switch and changeover switch of high-speed lines without degrading analog signals such as voice and images.

●Lineup

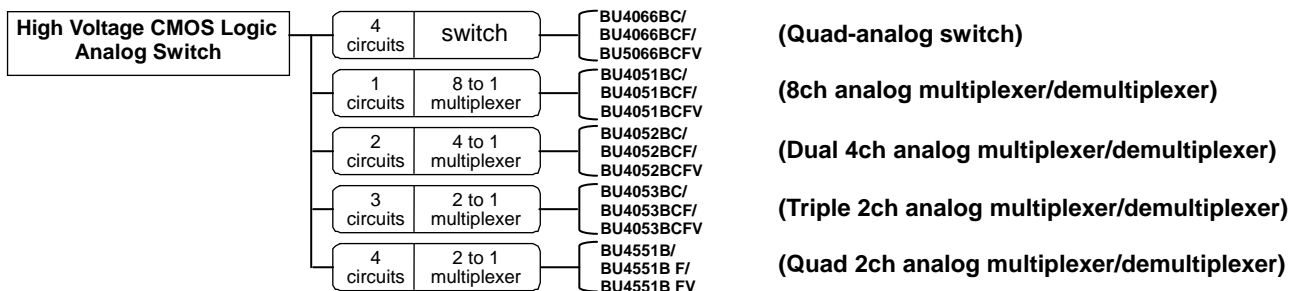

● Absolute Maximum Ratings

Parameter	Symbol	Limit					Unit
		BU4066BC	BU4051BC	BU4052BC	BU4053BC	BU4551B	
Power Supply Voltage	VDD	-0.5 to 20				-0.3 to 18	V
Supply current	Iin	±10					mA
Operating temperature	Topr	-40 to 85					°C
Storage temperature	Tstg	-55 to 150					°C
Input Voltage	VIN	-0.5 to VDD+0.5				-0.3 to VDD+0.3	V
Maximum junction temperature	Tjmax	150					°C

● Recommended Operating Conditions

Parameter	Symbol	Limit					Unit
		BU4066BC	BU4051BC	BU4052BC	BU4053BC	BU4551B	
Operating Power Supply	VDD	3 to 18				3 to 16	V
Input Voltage	VIN	0 to VDD					V

● Thermal Derating Curve

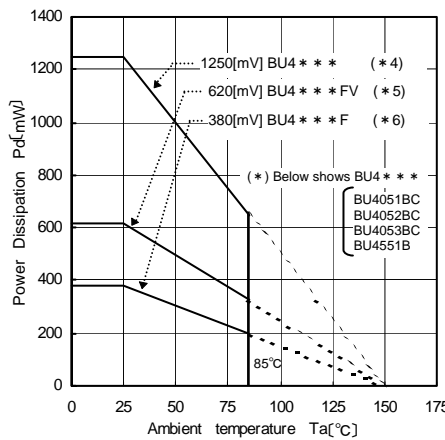
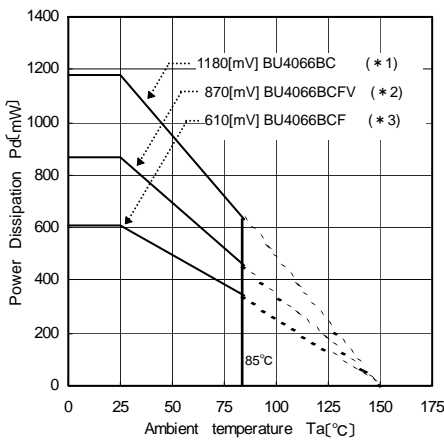

(*1)	9.5	mW/°C
(*2)	7.0	
(*3)	4.9	
(*4)	10.0	
(*5)	5.0	
(*6)	3.1	

When used at Ta=25[°C] or above, values of above are reduced per 1[°C]. Allowable loss is the value for mounting 70[mm] x 70[mm] x 1.6[mm] FR4 glass epoxy circuit board copper foil area is 3% or less).

● I/O Interface

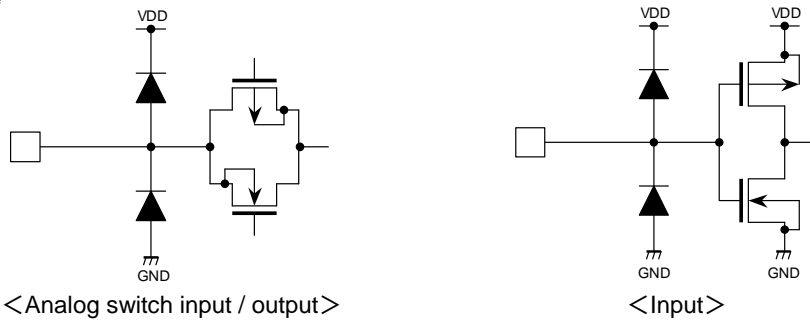

● Description of output rising / falling wave

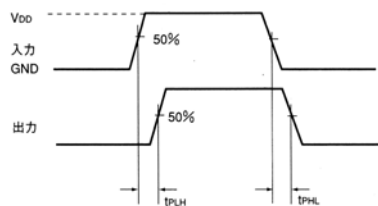

- tPLH: Time up to 50% of the rise time of input waveform ~ 50% of the rise time of output waveform
- tPHL: Time up to 50% of the fall time of input waveform ~ 50% of the fall time of output waveform

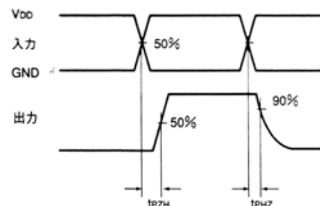

- tPZH: Time up to 50% of input ~ 50% of the rise time of output waveform
- tPHZ: Time up to 50% of input ~ 50% of the fall time of output waveform

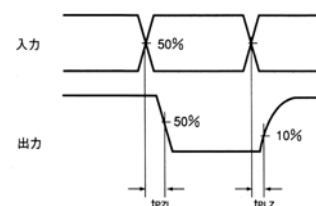

- tPZH: Time up to 50% of input ~ 50% of the fall time of output waveform
- tPHZ: Time up to 10% of input ~ 10% of the rise time of output waveform

●Electrical Characteristics(BU4066BC)

DC Characteristics(Unless otherwise noted, VSS=0[V], Ta=25[°C])

Parameter	Symbol	Standard Value			Unit	VDD[V]	Condition	Fig.No
		MIN	TYP	MAX				
Input "H" voltage	VIH	3.5	-	-	V	5	-	-
		7.0	-	-		10		
		11.0	-	-		15		
Input "L" voltage	VIL	-	-	1.5	V	5	-	-
		-	-	3.0		10		
		-	-	3.75		15		
Input "H" current	I _{IH}	-	-	0.3	μA	15	VIH=15[V]	-
Input "L" current	I _{IL}	-	-	-0.3	μA	15	VIL=0[V]	-
ON resistance	RON	-	150	600	Ω	5	VIN=0.25[V] RL=10[kΩ]	1
		-	500	950		5	VIN=2.5[V] RL=10[kΩ]	
		-	200	600		5	VIN=5[V] RL=10[kΩ]	
		-	120	500		10	VIN=5[V] RL=10[kΩ]	
		-	80	280		15	VIN=7.5[V] RL=10[kΩ]	
ON resistance defluxion	ΔRON	-	25	-	Ω	5	VI=VDD/2 RL=10[kΩ]	-
		-	10	-		10		
		-	5	-		15		
Channel-OFF Leakage current	IOFF	-	-	0.3	μA	15	VIN=15[V] VOUT=0[V]	-
		-	-	-0.3		15	VIN=0[V] VOUT=15[V]	
Static supply current	IDD	-	-	1.0	μA	5	VI=VDD or GND	-
		-	-	2.0		10		
		-	-	4.0		15		
Input capacitance (control input)	CC	-	8	-	pF	-	f=1[MHz]	-
Input capacitance (switch input)	CS	-	10	-	pF	-	f=1[MHz]	-

Switching Characteristics(Unless otherwise noted, VSS=0[V], Ta=25[°C], CL=50[pF])

Parameter	Symbol	Standard Value			Unit	VDD[V]	Condition	Fig.No
		MIN	TYP	MAX				
Propagation delay time SWIN→OUT	t _{PLH} t _{PHL}	-	20	50	ns	5	RL=10[kΩ]	2 · 3
		-	12	40		10		
		-	10	30		15		
Propagation delay time CONT→OUT	t _{PHZ} ,t _{PLZ} t _{PZH} ,t _{PZL}	-	40	90	ns	5	Output"Hi Z" →"Hi Z" RL=1[kΩ]	4 · 5 6 · 7
		-	35	80		10		
		-	30	70		15		
Propagation delay time CONT→OUT	t _{PHZ} ,t _{PLZ} t _{PZH} ,t _{PZL}	-	60	140	ns	5	Output"Hi Z" →"Hi Z" RL=1[kΩ]	4 · 5 6 · 7
		-	20	50		10		
		-	15	40		15		
Feed through attenuation	FT	-	0.7	-	MHz	5	VSS=-5[V] RL=10[kΩ]	-
Sine wave distortion	D	-	0.1	-	%	5	VSS=-5[V] RL=10[kΩ]	-
Cross talk (CONT→OUT)	CT _c	-	-	600	mVp-p	5	VSS=-5[V] RL=10[kΩ],f=1[MHz]	-
Cross talk(2) Between channels	CT	-	1	-	MHz	5	VSS=-5[V] RL=10[kΩ]	-

●Electrical Characteristics(BU4051BC)

DC Characteristics(Unless otherwise noted, VSS=0[V], Ta=25[°C])

Parameter	Symbol	Standard Value			Unit	VDD[V]	Condition	Fig.No
		MIN	TYP	MAX				
Input "H" voltage	VIH	3.5	-	-	V	5	-	-
		7.0	-	-		10		
		11.0	-	-		15		
Input "L" voltage	VIL	-	-	1.5	V	5	-	-
		-	-	3.0		10		
		-	-	4.0		15		
Input "H" current	I _{IH}	-	-	0.3	μA	15	VIH=15[V]	-
Input "L" current	I _{IL}	-	-	-0.3	μA	15	VIL=0[V]	-
ON resistance	RON	-	-	950	Ω	5	-	8
		-	-	250		10		
		-	-	160		15		
ON resistance defluxion	ΔRON	-	10	-	Ω	5	-	-
		-	6	-		10		
		-	4	-		15		
Channel-OFF Leakage current	IOFF	-	-	0.3	μA	15	-	-
		-	-	-0.3		15		
Static supply current	IDD	-	-	5	μA	5	VI=VDD or GND	-
		-	-	10		10		
		-	-	15		15		

Switching Characteristics(Unless otherwise noted, VSS=0[V], Ta=25[°C], CL=50[pF])

Parameter	Symbol	Standard Value			Unit	VDD[V]	Condition	Fig.No
		MIN	TYP	MAX				
Propagation delay time CHANNEL IN→OUT	tPLH tPHL	-	15	45	ns	5	-	9 · 10
		-	8	20		10		
		-	6	15		15		
Propagation delay time CONT→OUT	tPHZ,tPLZ tPZH,tPZL	-	170	550	ns	5	-	11 · 12 13 · 14 15 · 16 17 · 18
		-	90	240		10		
		-	70	160		15		
Propagation delay time INHIBIT→OUT	tPHZ,tPLZ tPZH,tPZL	-	150	450	ns	5	-	11 · 12 13 · 14 15 · 16 17 · 18
		-	70	210		10		
		-	50	160		15		
Maximum propagation frequency	fMAX.	-	20	-	MHz	5	VEE=-5[V]	-
Feed through attenuation	FT	-	0.5	-	MHz	5	VEE=-5[V]	-
Sine wave distortion	D	-	0.02	-	%	5	VEE=-5[V]	-
Input capacitance (control input)	CC	-	5	-	pF	-	-	-
Input capacitance (switch input)	CS	-	10	-	pF	-	-	-

●Electrical Characteristics(BU4052BC)

DC Characteristics(Unless otherwise noted, VSS=0[V], Ta=25[°C])

Parameter	Symbol	Standard Value			Unit	VDD[V]	Condition	Fig.No
		MIN	TYP	MAX				
Input "H" voltage	VIH	3.5	-	-	V	5	-	-
		7.0	-	-		10		
		11.0	-	-		15		
Input "L" voltage	VIL	-	-	1.5	V	5	-	-
		-	-	3.0		10		
		-	-	4.0		15		
Input "H" current	I _{IH}	-	-	0.3	μA	15	VIH=15[V]	-
Input "L" current	I _{IL}	-	-	-0.3	μA	15	VIL=0[V]	-
ON resistance	RON	-	-	950	Ω	5	-	19
		-	-	250		10		
		-	-	160		15		
ON resistance defluxion	ΔRON	-	10	-	Ω	5	-	-
		-	6	-		10		
		-	4	-		15		
Channel-OFF Leakage current	IOFF	-	-	0.3	μA	15	-	-
		-	-	-0.3		15		
Static supply current	IDD	-	-	5	μA	5	VI=VDD or GND	-
		-	-	10		10		
		-	-	15		15		

Switching Characteristics(Unless otherwise noted, Ta=25°C, CL=50pF)

Parameter	Symbol	Standard Value			Unit	VDD[V]	Condition	Fig.No
		MIN	TYP	MAX				
Propagation delay time SWITCH IN→OUT	t _{PLH} t _{PHL}	-	15	45	ns	5	-	20 · 21
		-	8	20		10		
		-	6	15		15		
Propagation delay time CONT→OUT	t _{PHZ} ,t _{PLZ} t _{PZH} ,t _{PZL}	-	170	550	ns	5	-	22 · 23 24 · 25
		-	90	240		10		
		-	70	160		15		
Propagation delay time INH→OUT	t _{PHZ} ,t _{PLZ} t _{PZH} ,t _{PZL}	-	150	450	ns	5	-	26 · 27 28 · 29
		-	70	210		10		
		-	50	160		15		
Maximum propagation frequency	f _{MAX.}	-	20	-	MHz	5	VEE=-5[V]	-
Feed through attenuation	FT	-	0.5	-	MHz	5	VEE=-5[V]	-
Sine wave distortion	D	-	0.02	-	%	5	VEE=-5[V]	-
Input capacitance (control input)	CC	-	5	-	pF	-	-	-
Input capacitance (switch input)	CS	-	10	-	pF	-	-	-

●Electrical Characteristics(BU4053BC)

DC Characteristics(Unless otherwise noted, VSS=0[V], Ta=25[°C])

Parameter	Symbol	Standard Value			Unit	VDD[V]	Condition	Fig.No
		MIN	TYP	MAX				
Input "H" voltage	VIH	3.5	-	-	V	5	-	-
		7.0	-	-		10		
		11.0	-	-		15		
Input "L" voltage	VIL	-	-	1.5	V	5	-	-
		-	-	3.0		10		
		-	-	4.0		15		
Input "H" current	I _{IH}	-	-	0.3	μA	15	VIH=15[V]	-
Input "L" current	I _{IL}	-	-	-0.3	μA	15	VIL=0[V]	-
RON resistance	RON	-	-	950	Ω	5	-	30
		-	-	250		10		
		-	-	160		15		
RON resistance defluxion	ΔRON	-	10	-	Ω	5	-	-
		-	6	-		10		
		-	4	-		15		
Channel-OFF Leakage current	IOFF	-	-	0.3	μA	15	-	-
		-	-	-0.3		15		
Static supply current	IDD	-	-	5	μA	5	VI=VDD or GND	-
		-	-	10		10		
		-	-	15		15		

Switching Characteristics(Unless otherwise noted, VSS=0[V], Ta=25[°C], CL=50[pF])

Parameter	Symbol	Standard Value			Unit	VDD[V]	Condition	Fig.No
		MIN	TYP	MAX				
Propagation delay time SW IN→OUT	t _{PLH} t _{PHL}	-	15	45	ns	5	-	31 · 32
		-	8	20		10		
		-	6	15		15		
Propagation delay time CONT→OUT	t _{PHZ} ,t _{PLZ} t _{PZH} ,t _{PZL}	-	170	550	ns	5	-	33 · 34 35 · 36
		-	90	240		10		
		-	70	160		15		
Propagation delay time INH→OUT	t _{PHZ} ,t _{PLZ} t _{PZH} ,t _{PZL}	-	150	380	ns	5	-	37 · 38 39 · 40
		-	70	200		10		
		-	50	160		15		
Maximum propagation frequency	f _{MAX.}	-	20	-	MHz	5	VEE=-5[V]	-
Feed through attenuation	FT	-	0.7	-	MHz	5	VEE=-5[V]	-
Sine wave distortion	D	-	0.02	-	%	5	VEE=-5[V]	-
Input capacitance (control input)	CC	-	5	-	pF	-	-	-
Input capacitance (switch input)	CS	-	10	-	pF	-	-	-

● Electrical Characteristics(BU4551BC)

DC Characteristics(Unless otherwise noted, VSS=0[V], Ta=25[°C])

Parameter	Symbol	Standard Value			Unit	VDD[V]	Condition	Fig.No
		MIN	TYP	MAX				
Input "H" voltage	VIH	3.5	-	-	V	5	-	-
		7.0	-	-		10		
		11.0	-	-		15		
Input "L" voltage	VIL	-	-	1.5	V	5	-	-
		-	-	3.0		10		
		-	-	4.0		15		
Input "H" current	I _{IH}	-	-	0.3	μA	15	VIH=15[V]	-
Input "L" current	I _{IL}	-	-	-0.3	μA	15	VIL=0[V]	-
ON resistance	RON	-	-	1100	Ω	5	-	41
		-	-	500		10		
		-	-	280		15		
ON resistance defluxion	ΔRON	-	25	-	Ω	5	-	-
		-	10	-		10		
		-	5	-		15		
Channel-OFF Leakage current	IOFF	-	-	0.3	μA	15	-	-
		-	-	-0.3		15		
Static supply current	IDD	-	-	5	μA	5	VI=VDD or GND	-
		-	-	10		10		
		-	-	15		15		

Switching Characteristics(Unless otherwise noted, VSS=0[V], Ta=25[°C], CL=50[pF])

Parameter	Symbol	Standard Value			Unit	VDD[V]	Condition	Fig.No
		MIN	TYP	MAX				
Propagation delay time SW IN→OUT	t _{PLH} t _{PHL}	-	35	-	ns	5	-	42 · 43
		-	15	-		10		
		-	12	-		15		
Propagation delay time CONT→OUT	t _{PZH} t _{PHZ}	-	360	-	ns	5	-	44 · 45
		-	160	-		10		
		-	120	-		15		
Propagation delay time INH→OUT	t _{PZL} t _{PLZ}	-	360	-	ns	5	-	46 · 47
		-	160	-		10		
		-	120	-		15		
Maximum propagation frequency	f _{MAX.}	-	15	-	MHz	-	VEE=-5[V]	-
Feed through attenuation	FT	-	0.7	-	MHz	-	VEE=-5[V]	-
Sine wave distortion	D	-	0.02	-	%	-	VEE=-5[V]	-
Input capacitance (control input)	CC	-	5	-	pF	-	-	-
Input capacitance (switch input)	CS	-	10	-	pF	-	-	-

● Reference Data (BU4066BC)

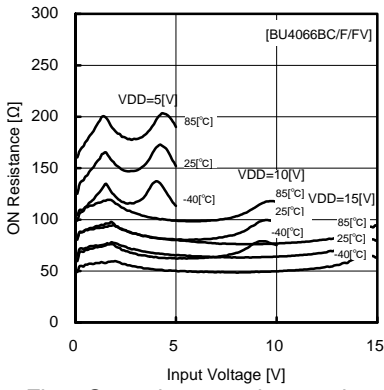

Fig.1 On resistance – input voltage

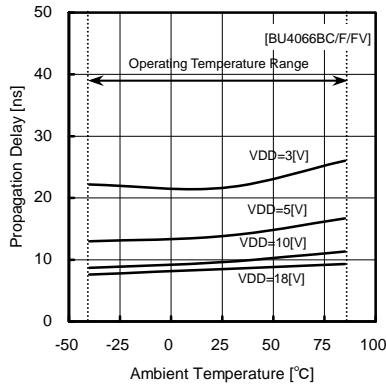

Fig.2 rising propagation delay (IN – OUT)

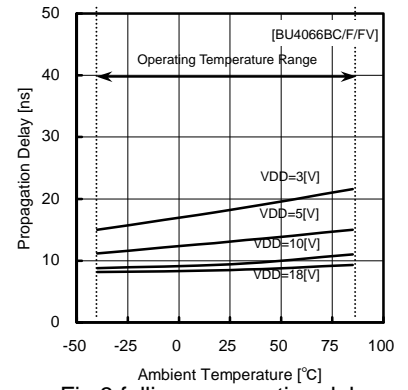

Fig.3 falling propagation delay (IN – OUT)

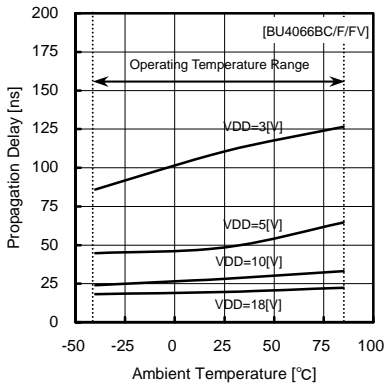

Fig.4 rising propagation delay (CONT – OUT, tPZH)

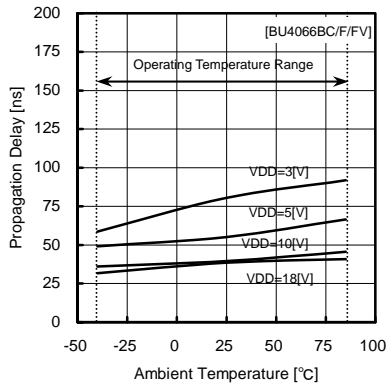

Fig.5 falling propagation delay (CONT – OUT, tPHZ)

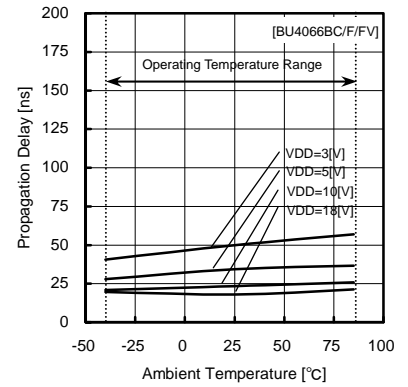

Fig.6 rising propagation delay (CONT – OUT, tPLZ)

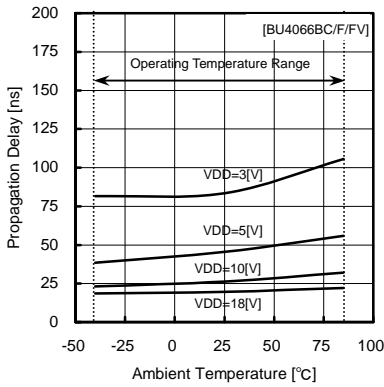

Fig.7 falling propagation delay (CONT – OUT, tPZL)

●Reference Data(BU4051BC)

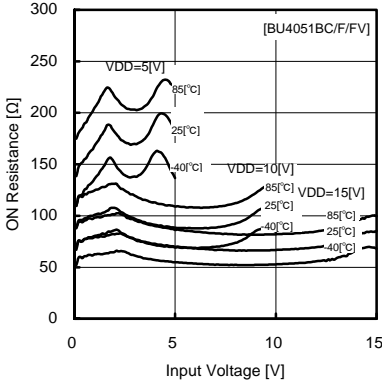

Fig.8 ON resistance – input voltage

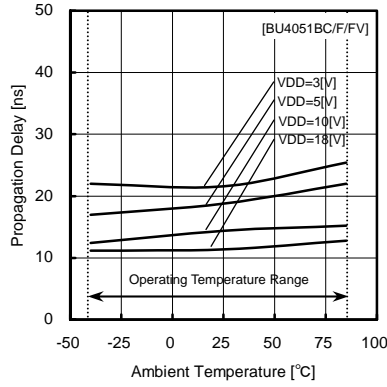

Fig.9 propagation delay time tPLH (IN – OUT)

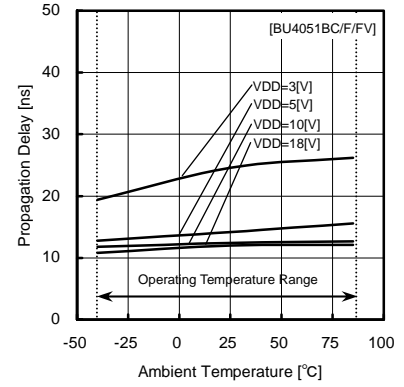

Fig.10 propagation delay time tPHL (IN – OUT)

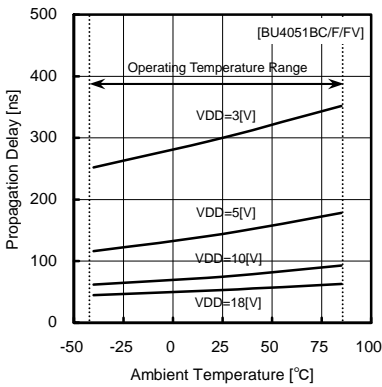

Fig.11 propagation delay time tPZH (CONT – OUT)

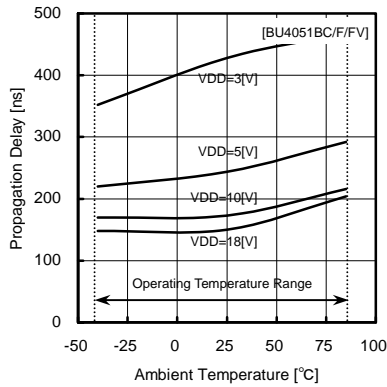

Fig.12 propagation delay time tPHZ (CONT – OUT)

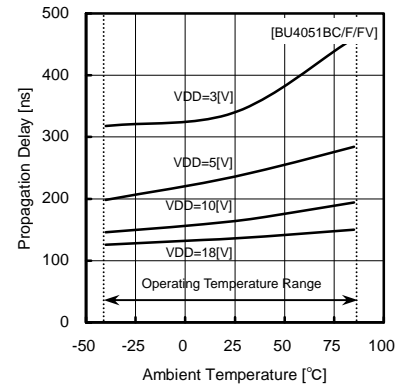

Fig.13 propagation delay time tPLZ (CONT – OUT)

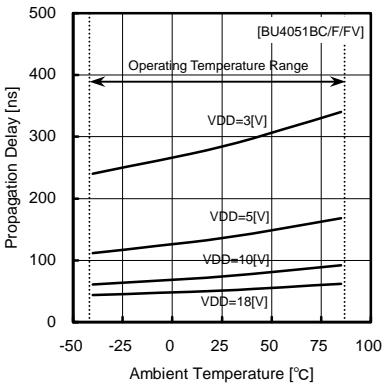

Fig.14 propagation delay time tPZL (CONT – OUT)

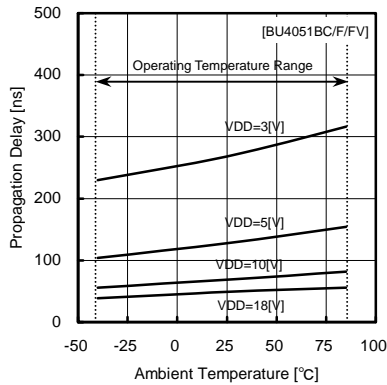

Fig.15 propagation delay time tPZH (INH – OUT)

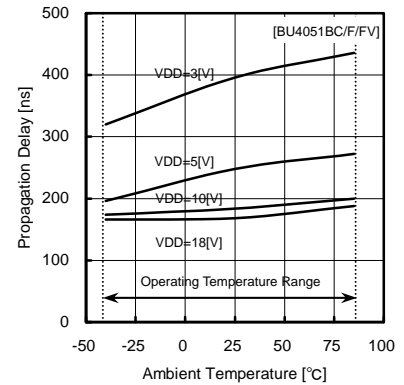

Fig.16 propagation delay time tPHZ (INH – OUT)

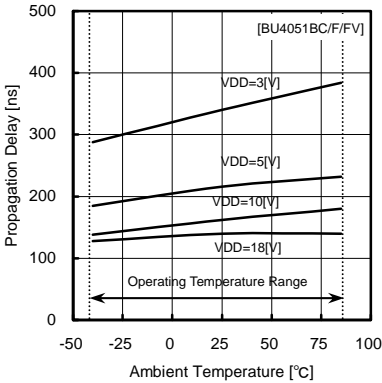

Fig.17 propagation delay time tPZL (INH – OUT)

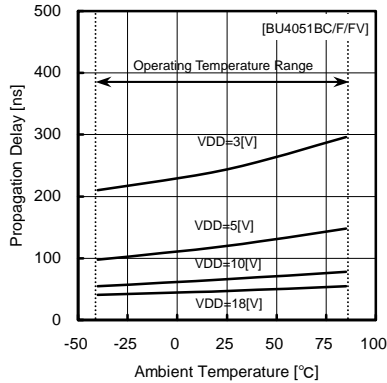

Fig.18 propagation delay time tPLZ (INH – OUT)

●Reference Data(BU4052BC)

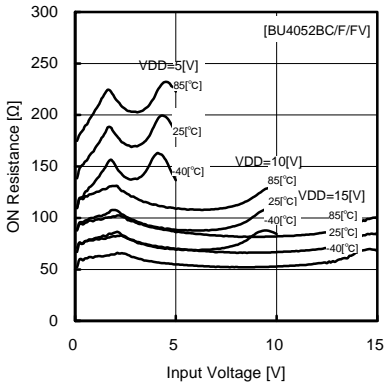

Fig.19 ON resistance – input voltage

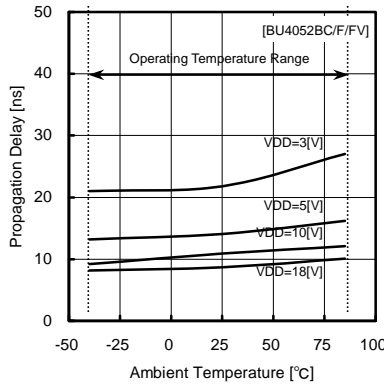

Fig.20 propagation delay time tPLH (IN – OUT)

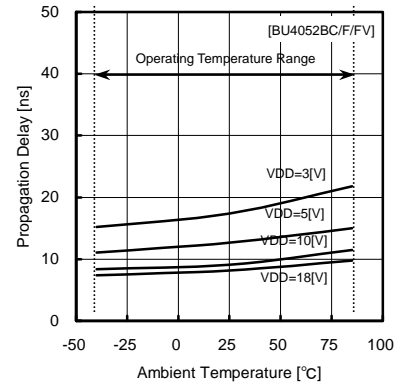

Fig.21 propagation delay time tPHL (IN – OUT)

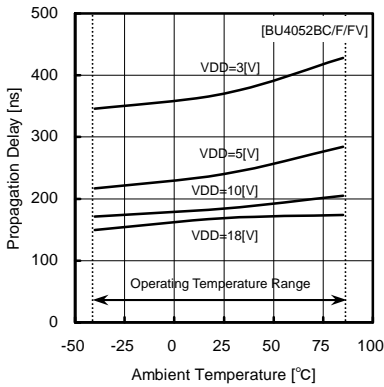

Fig.22 propagation delay time tPZH (CONT – OUT)

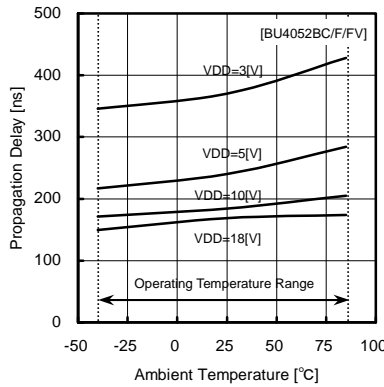

Fig.23 propagation delay time tPHZ (CONT – OUT)

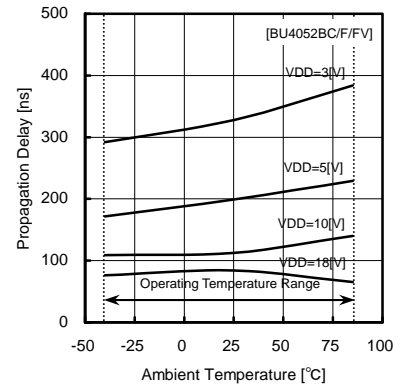

Fig.24 propagation delay time tPLZ (CONT – OUT)

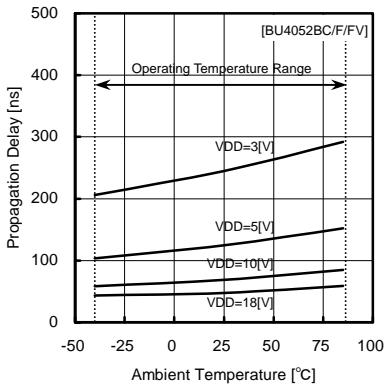

Fig.25 propagation delay time tPZL (CONT – OUT)

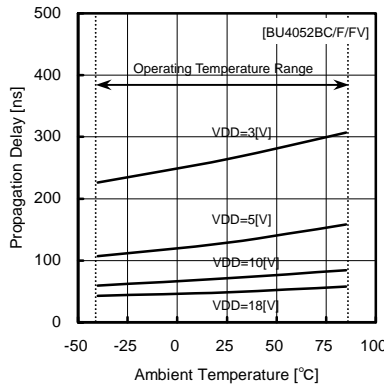

Fig.26 propagation delay time tPZH (INH – OUT)

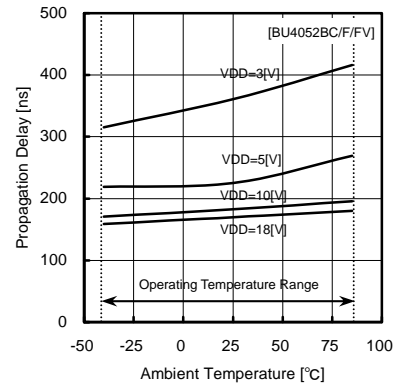

Fig.27 propagation delay time tPHZ (INH – OUT)

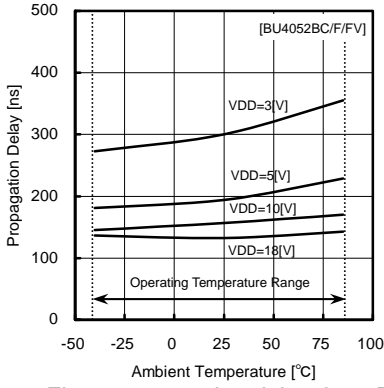

Fig.28 propagation delay time tPZL (INH – OUT)

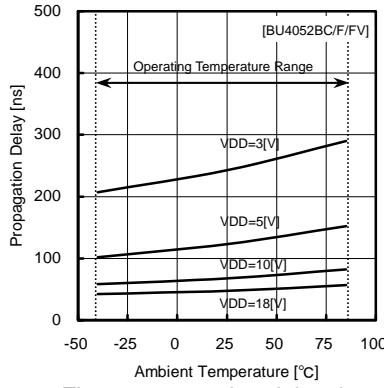

Fig.29 propagation delay time tPLZ (INH – OUT)

●Reference Data(BU4053BC)

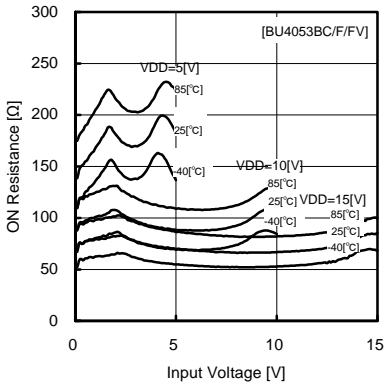

Fig.30 ON resistance—input voltage

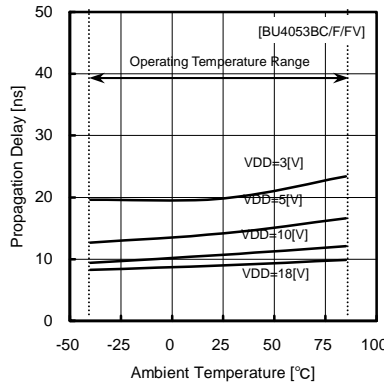

Fig.31 propagation delay time tPLH (IN—OUT)

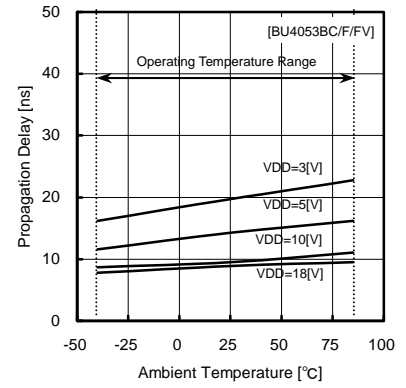

Fig.32 propagation delay time tPHL (IN—OUT)

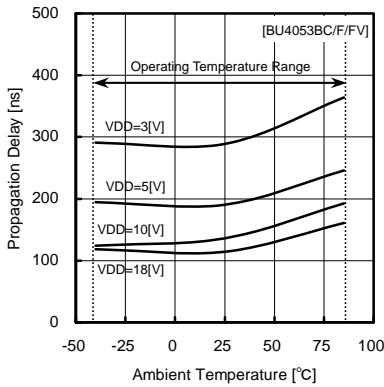

Fig.33 propagation delay time tPZH (CONT—OUT)

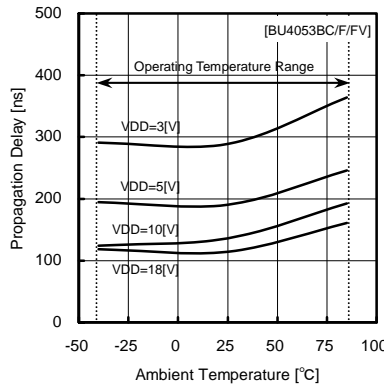

Fig.34 propagation delay time tPHZ (CONT—OUT)

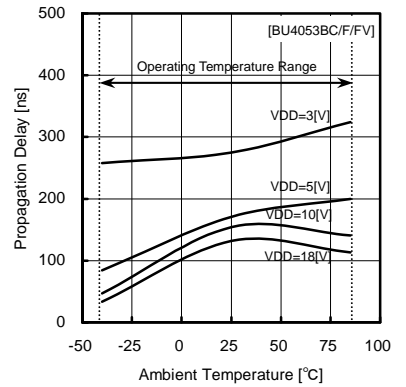

Fig.35 propagation delay time tPLZ (CONT—OUT)

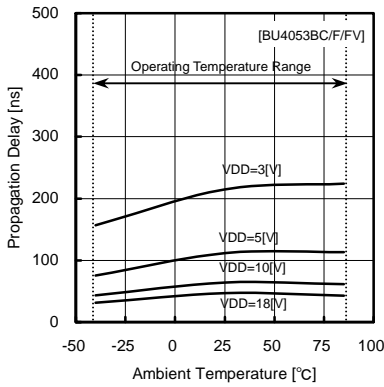

Fig.36 propagation delay time tPZL (CONT—OUT)

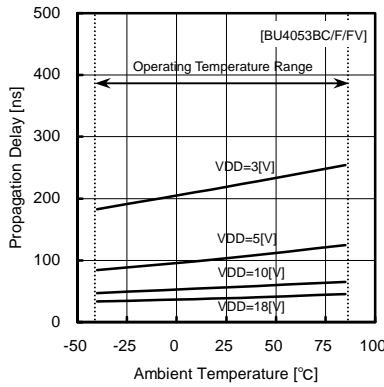

Fig.37 propagation delay time tPZH (INH—OUT)

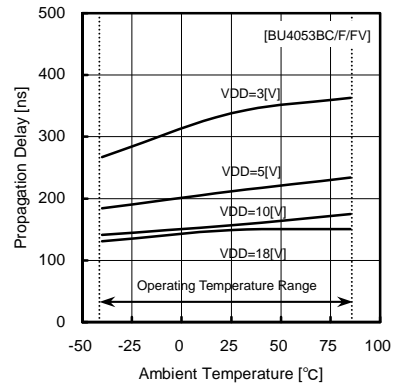

Fig.38 propagation delay time tPHZ (INH—OUT)

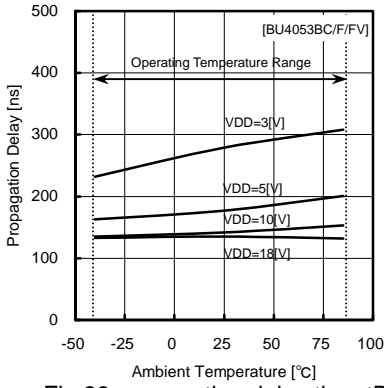

Fig.39 propagation delay time tPZL (INH—OUT)

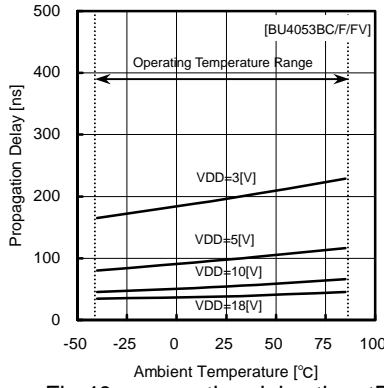

Fig.40 propagation delay time tPLZ (INH—OUT)

●Reference Data(BU4551B)

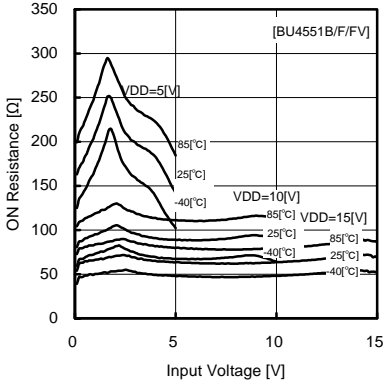

Fig.41 ON resistance – input voltage

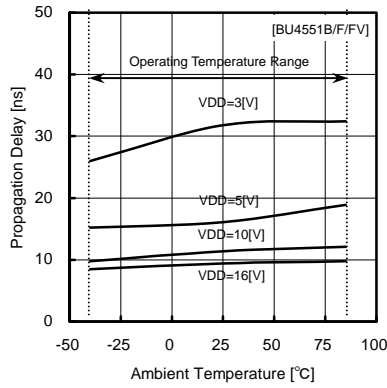

Fig.42 propagation delay time tPLH (IN – OUT)

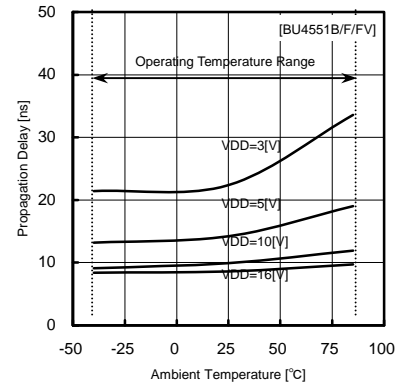

Fig.43 propagation delay time tPHL (IN – OUT)

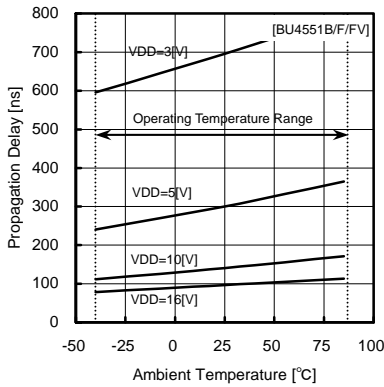

Fig.44 propagation delay time tPZH (CONT – OUT)

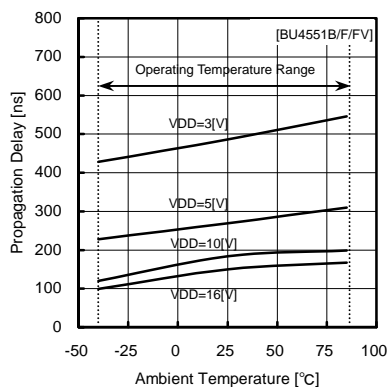

Fig.45 propagation delay time tPHZ (CONT – OUT)

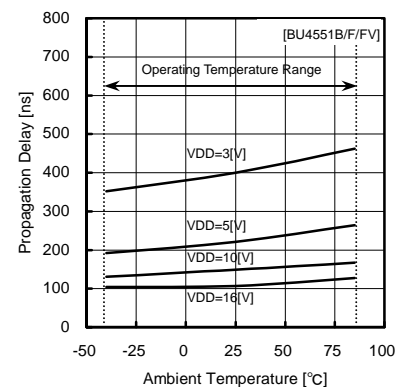

Fig.46 propagation delay time tPLZ (CONT – OUT)

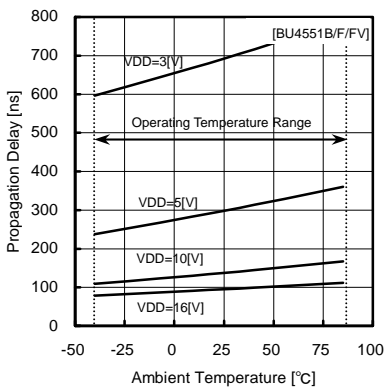
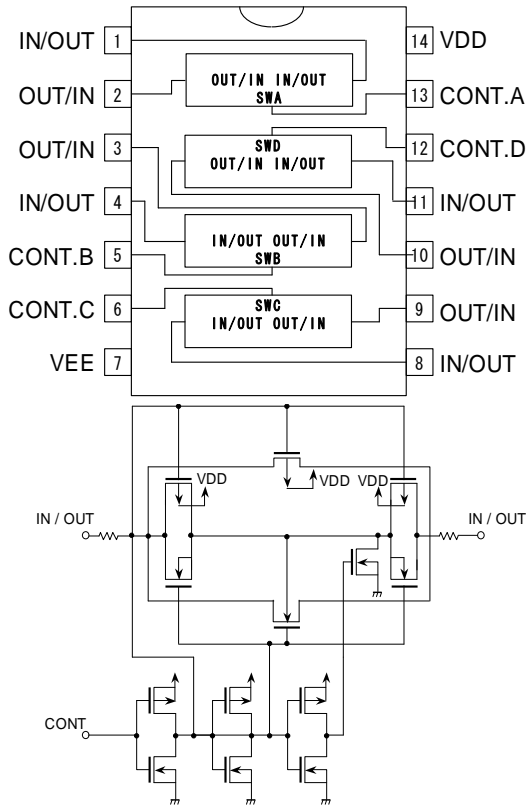

Fig.47 propagation delay time tPZL (CONT – OUT)

● Pin Configuration • Pin Function • Block Diagram • Truth Table

1) BU4066BC Series



PIN FUNCTION

PIN No.	PIN NAME	I/O	PIN FUNCTION
1	IN/OUT	I/O	Analog Switch Input / Output
2	OUT/IN	I/O	Analog Switch Input / Output
3	OUT/IN	I/O	Analog Switch Input / Output
4	IN/OUT	I/O	Analog Switch Input / Output
5	CONT.B	I	Control Input
6	CONT.C	I	Control Input
7	VEE	-	Power Supply(-)
8	IN/OUT	I/O	Analog Switch Input / Output
9	OUT/IN	I/O	Analog Switch Input / Output
10	OUT/IN	I/O	Analog Switch Input / Output
11	IN/OUT	I/O	Analog Switch Input / Output
12	CONT.D	I	Control Input
13	CONT.A	I	Control Input
14	VDD	-	Power Supply(+)

TRUTH TABLE

CONTROL	ON SWITCH
A	A(1pin-2pin)
B	B(3pin-4pin)
C	C(8pin-9pin)
D	D(10pin-11pin)

2) BU4051BC Series

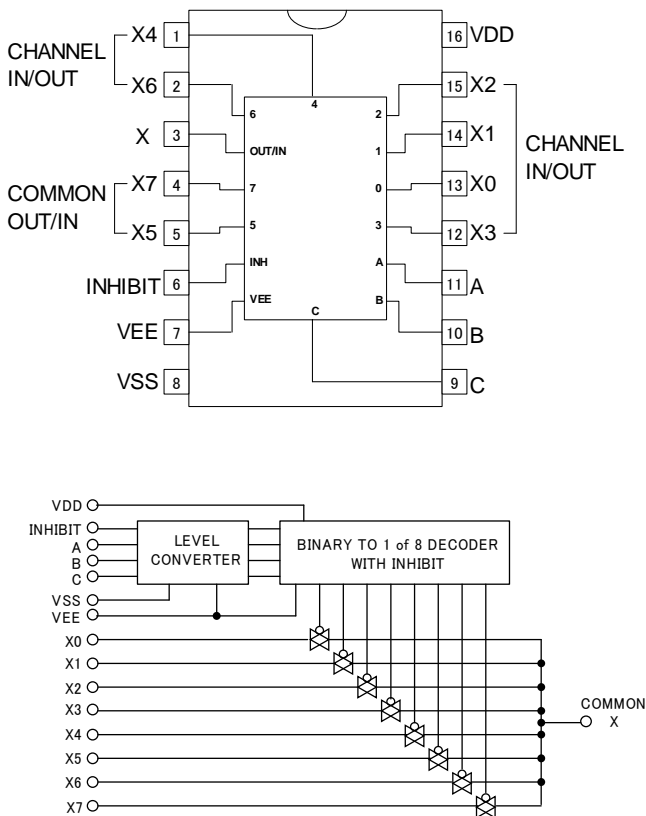

PIN FUNCTION

PIN No.	PIN NAME	I/O	PIN FUNCTION
1	X4	I/O	Analog Switch Input / Output
2	X6	I/O	Analog Switch Input / Output
3	X	I/O	Analog Switch Input / Output
4	X7	I/O	Analog Switch Input / Output
5	X5	I/O	Analog Switch Input / Output
6	INHIBIT	I	Control Input
7	VEE	-	Power Supply(-)
8	VSS	-	Power Supply(-)
9	C	I	Control Input
10	B	I	Control Input
11	A	I	Control Input
12	X3	I/O	Analog Switch Input / Output
13	X0	I/O	Analog Switch Input / Output
14	X1	I/O	Analog Switch Input / Output
15	X2	I/O	Analog Switch Input / Output
16	VDD	-	Power Supply(+)

TRUTH TABLE

INHIBIT	A	B	C	ON SWITCH
L	L	L	L	X0
L	H	L	L	X1
L	L	H	L	X2
L	H	H	L	X3
L	L	L	H	X4
L	H	L	H	X5
L	L	H	H	X6
L	H	H	H	X7
H	X	X	X	NONE

3) BU4052BC Series

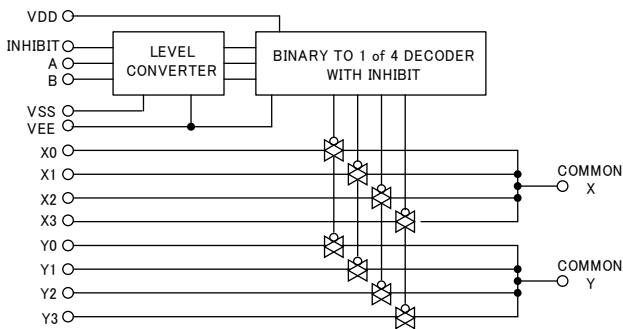
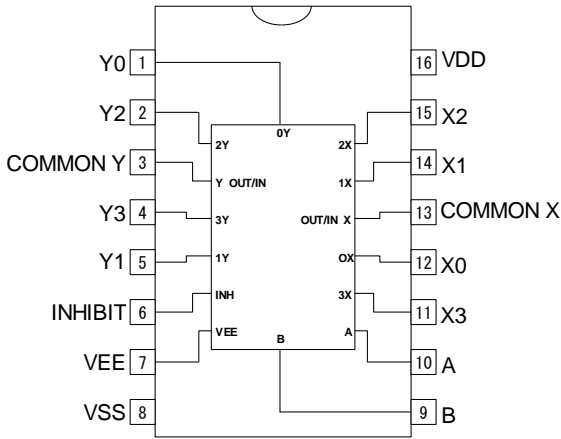

PIN FUNCTION

PIN No.	PIN NAME	I/O	PIN FUNCTION
1	Y0	I/O	Analog Switch Input / Output
2	Y2	I/O	Analog Switch Input / Output
3	COMMON Y	I/O	Analog Switch Input / Output
4	Y3	I/O	Analog Switch Input / Output
5	Y1	I/O	Analog Switch Input / Output
6	INHIBIT	I	Control Input
7	VEE	-	Power Supply(-)
8	VSS	-	Power Supply(-)
9	B	I	Control Input
10	A	I	Control Input
11	X3	I/O	Analog Switch Input / Output
12	X0	I/O	Analog Switch Input / Output
13	COMMON X	I/O	Analog Switch Input / Output
14	X1	I/O	Analog Switch Input / Output
15	X2	I/O	Analog Switch Input / Output
16	VDD	-	Power Supply(+)

TRUTH TABLE

INHIBIT	A	B	ON SWITCH
L	L	L	X0, Y0
L	H	L	X1, Y1
L	L	H	X2, Y2
L	H	H	X3, Y3
H	X	X	NONE

4) BU4053BC Series

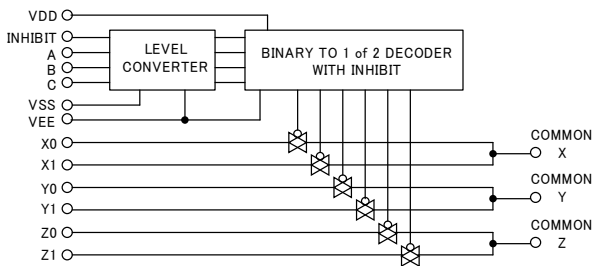
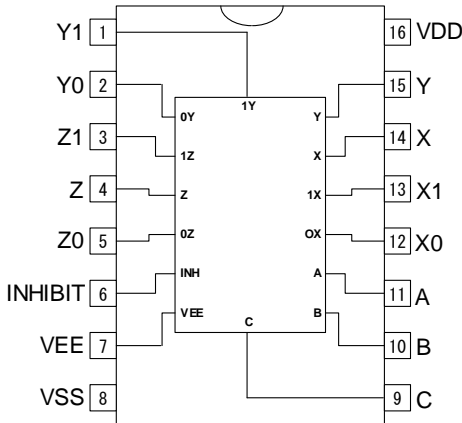

PIN FUNCTION

PIN No.	PIN NAME	I/O	PIN FUNCTION
1	Y1	I/O	Analog Switch Input / Output
2	Y0	I/O	Analog Switch Input / Output
3	Z1	I/O	Analog Switch Input / Output
4	Z	I/O	Analog Switch Input / Output
5	Z0	I/O	Analog Switch Input / Output
6	INHIBIT	I	Control Input
7	VEE	-	Power Supply(-)
8	VSS	-	Power Supply(-)
9	C	I	Control Input
10	B	I	Control Input
11	A	I	Control Input
12	X0	I/O	Analog Switch Input / Output
13	X1	I/O	Analog Switch Input / Output
14	X	I/O	Analog Switch Input / Output
15	Y	I/O	Analog Switch Input / Output
16	VDD	-	Power Supply(+)

TRUTH TABLE

INHIBIT	A	B	C	ON SWITCH
L	L	L	L	X0, Y0, Z0
L	H	L	L	X1, Y0, Z0
L	L	H	L	X0, Y1, Z0
L	H	H	L	X1, Y1, Z0
L	L	L	H	X0, Y0, Z1
L	H	L	H	X1, Y0, Z1
L	L	H	H	X0, Y1, Z1
L	H	H	H	X1, Y1, Z1
H	X	X	X	NONE

5) BU4551B Series

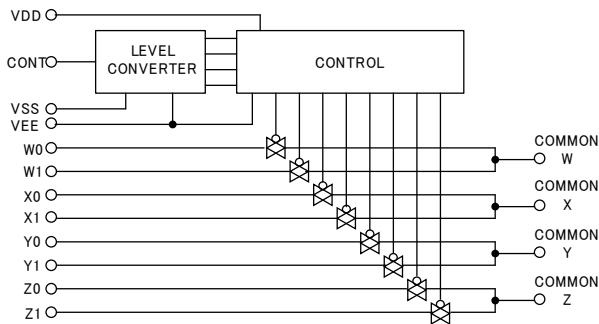
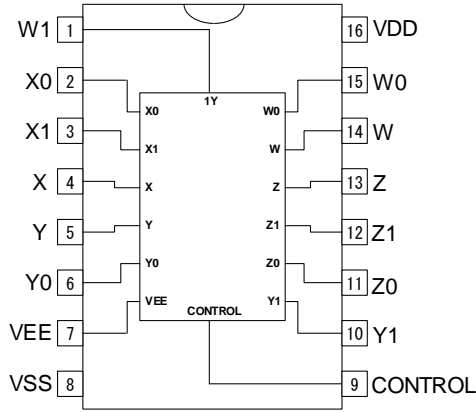

PIN FUNCTION

PIN No.	PIN NAME	I/O	PIN FUNCTION
1	W1	I/O	Analog Switch Input / Output
2	X0	I/O	Analog Switch Input / Output
3	X1	I/O	Analog Switch Input / Output
4	X	I/O	Analog Switch Input / Output
5	Y	I/O	Analog Switch Input / Output
6	Y0	I/O	Analog Switch Input / Output
7	VEE	-	Power Supply(-)
8	VSS	-	Power Supply(-)
9	CONTROL	I	Control Input
10	Y1	I/O	Analog Switch Input / Output
11	Z0	I/O	Analog Switch Input / Output
12	Z1	I/O	Analog Switch Input / Output
13	Z	I/O	Analog Switch Input / Output
14	W	I/O	Analog Switch Input / Output
15	W0	I/O	Analog Switch Input / Output
16	VDD	-	Power Supply(+)

TRUTH TABLE

CONTROL	ON SWITCH
0	W0, X0, Y0, Z0
1	W1, X1, Y1, Z1

●Notes for use

- Absolute maximum ratings**
An excess in the absolute maximum ratings, such as supply voltage, temperature range of operating conditions, etc., can break down the devices, thus making impossible to identify breaking mode, such as short circuit or an open circuit. If any over rated values will expect to exceed the absolute maximum ratings, consider adding circuit protection devices, such as fuses.
- Connecting the power supply connector backward**
Connecting of the power supply in reverse polarity can damage IC. Take precautions when connecting the power supply lines. An external direction diode can be added.
- Power Supply lines**
Design PCB layout pattern to provide low impedance GND and supply lines. To obtain a low noise ground and supply line, separate the ground section and supply lines of the digital and analog blocks. Furthermore, for all power terminals to ICs, connect a capacitor between the power supply and the GND terminal. When applying electrolytic capacitors in the circuit, not that capacitance characteristic values are reduced at low temperatures.
- GND voltage**
The potential of GND pin must be minimum potential in all operating conditions.
- Thermal design**
Use a thermal design that allows for a sufficient margin in light of the power dissipation (Pd) in actual operating conditions.
- Inter-pin shorts and mounting errors**
Use caution when positioning the IC for mounting on printed circuit boards. The IC may be damaged if there is any connection error or if pins are shorted together.
- Actions in strong electromagnetic field**
Use caution when using the IC in the presence of a strong electromagnetic field as doing so may cause the IC to malfunction.
- Testing on application boards**
When testing the IC on an application board, connecting a capacitor to a pin with low impedance subjects the IC to stress. Always discharge capacitors after each process or step. Always turn the IC's power supply off before connecting it to or remove it from a jig or fixture during the inspection process. Ground the IC during assembly steps as an antistatic measure. Use similar precaution when transporting or storing the IC.
- 9. Ground Wiring Pattern**
When using both small signal and large current GND patterns, it is recommended to isolate the two ground patterns, placing a signal ground point at the ground potential of application so that the pattern wiring resistance and voltage variations caused by large currents do not cause variations in the small signal ground voltage. Be careful not to change the GND wiring pattern of any external components, either.

● Ordering part number

B	U		4	5	5	1	B		F	V	-	E	2
Part No.		Part No.		Part No.		Part No.		Package		Packaging and forming specification			
		4066BC		4053BC		4051BC		None: DIP14, DIP16		E2: Embossed tape and reel			
		4052BC		4551B		4052BC		F : SOP14, SOP16		None: Tray, Tube			
								FV : SSOP-B14					
								SSOP-B16					

SOP14

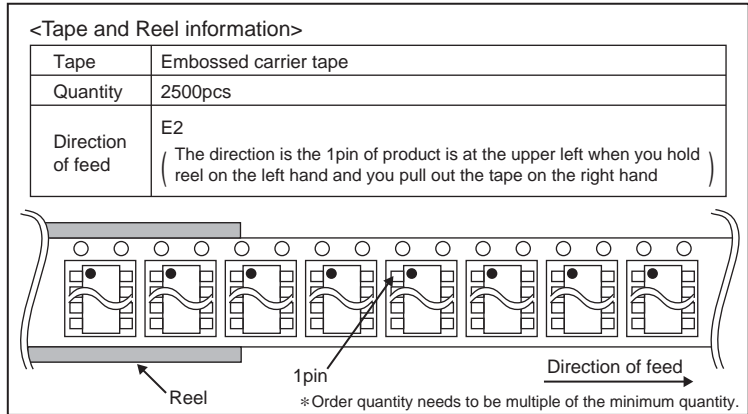
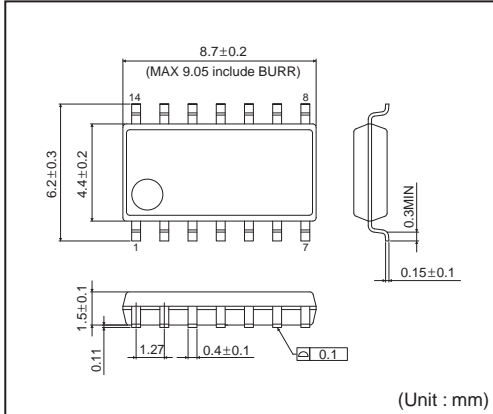

SSOP-B14

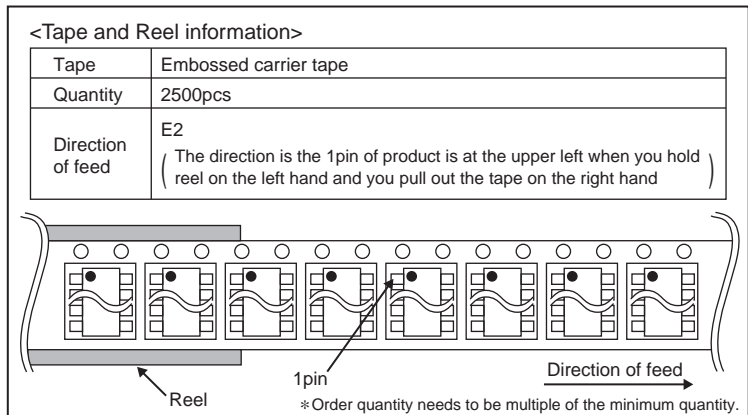
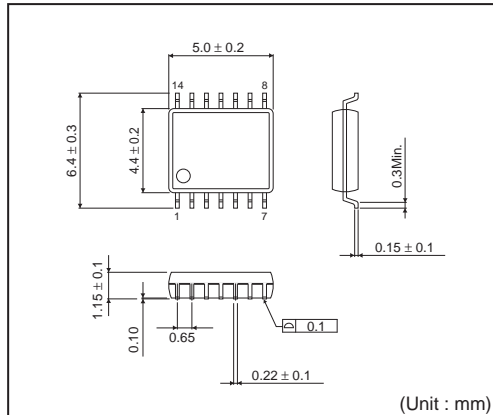

DIP14

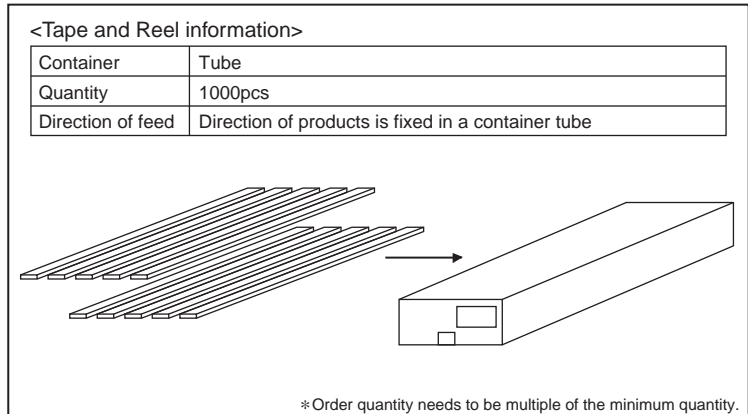
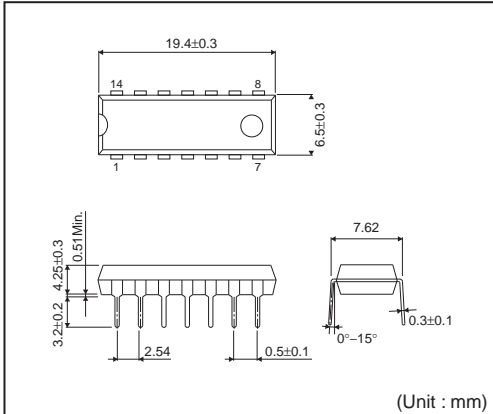

SOP16

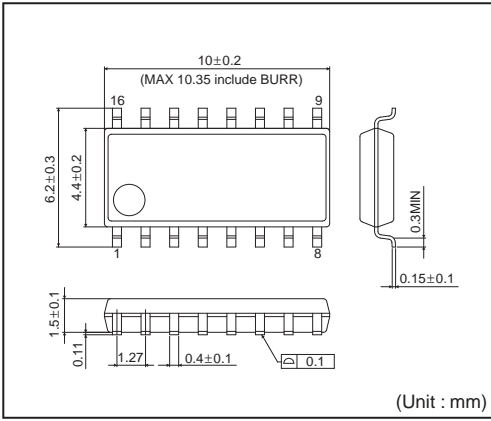

<Tape and Reel information>

Tape	Embossed carrier tape
Quantity	2500pcs
Direction of feed	E2 (The direction is the 1pin of product is at the upper left when you hold reel on the left hand and you pull out the tape on the right hand)

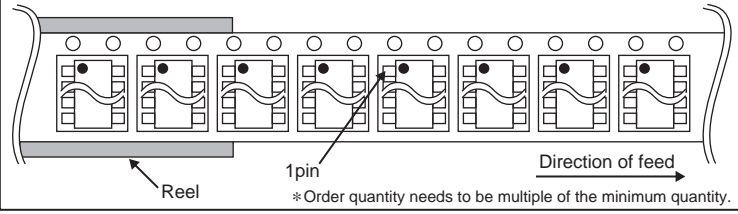

SSOP-B16

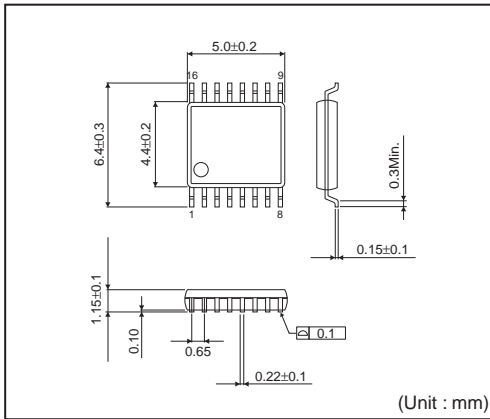

<Tape and Reel information>

Tape	Embossed carrier tape
Quantity	2500pcs
Direction of feed	E2 (The direction is the 1pin of product is at the upper left when you hold reel on the left hand and you pull out the tape on the right hand)

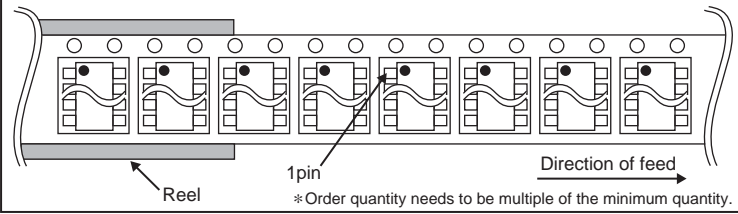

DIP16

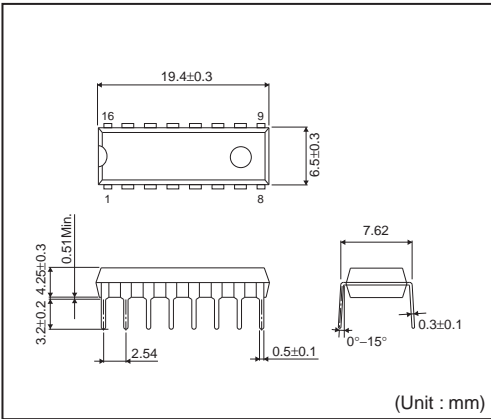

<Tape and Reel information>

Container	Tube
Quantity	1000pcs
Direction of feed	Direction of products is fixed in a container tube

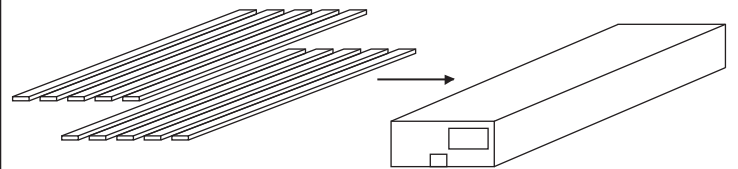

*Order quantity needs to be multiple of the minimum quantity.

Notice

Precaution on using ROHM Products

- Our Products are designed and manufactured for application in ordinary electronic equipments (such as AV equipment, OA equipment, telecommunication equipment, home electronic appliances, amusement equipment, etc.). If you intend to use our Products in devices requiring extremely high reliability (such as medical equipment ^(Note 1), transport equipment, traffic equipment, aircraft/spacecraft, nuclear power controllers, fuel controllers, car equipment including car accessories, safety devices, etc.) and whose malfunction or failure may cause loss of human life, bodily injury or serious damage to property ("Specific Applications"), please consult with the ROHM sales representative in advance. Unless otherwise agreed in writing by ROHM in advance, ROHM shall not be in any way responsible or liable for any damages, expenses or losses incurred by you or third parties arising from the use of any ROHM's Products for Specific Applications.

(Note1) Medical Equipment Classification of the Specific Applications

JAPAN	USA	EU	CHINA
CLASS III	CLASS III	CLASS II b	CLASS III
CLASS IV		CLASS III	

- ROHM designs and manufactures its Products subject to strict quality control system. However, semiconductor products can fail or malfunction at a certain rate. Please be sure to implement, at your own responsibilities, adequate safety measures including but not limited to fail-safe design against the physical injury, damage to any property, which a failure or malfunction of our Products may cause. The following are examples of safety measures:
 - Installation of protection circuits or other protective devices to improve system safety
 - Installation of redundant circuits to reduce the impact of single or multiple circuit failure
- Our Products are designed and manufactured for use under standard conditions and not under any special or extraordinary environments or conditions, as exemplified below. Accordingly, ROHM shall not be in any way responsible or liable for any damages, expenses or losses arising from the use of any ROHM's Products under any special or extraordinary environments or conditions. If you intend to use our Products under any special or extraordinary environments or conditions (as exemplified below), your independent verification and confirmation of product performance, reliability, etc. prior to use, must be necessary:
 - Use of our Products in any types of liquid, including water, oils, chemicals, and organic solvents
 - Use of our Products outdoors or in places where the Products are exposed to direct sunlight or dust
 - Use of our Products in places where the Products are exposed to sea wind or corrosive gases, including Cl₂, H₂S, NH₃, SO₂, and NO₂
 - Use of our Products in places where the Products are exposed to static electricity or electromagnetic waves
 - Use of our Products in proximity to heat-producing components, plastic cords, or other flammable items
 - Sealing or coating our Products with resin or other coating materials
 - Use of our Products without cleaning residue of flux (even if you use no-clean type fluxes, cleaning residue of flux is recommended); or Washing our Products by using water or water-soluble cleaning agents for cleaning residue after soldering
 - Use of the Products in places subject to dew condensation
- The Products are not subject to radiation-proof design.
- Please verify and confirm characteristics of the final or mounted products in using the Products.
- In particular, if a transient load (a large amount of load applied in a short period of time, such as pulse. is applied, confirmation of performance characteristics after on-board mounting is strongly recommended. Avoid applying power exceeding normal rated power; exceeding the power rating under steady-state loading condition may negatively affect product performance and reliability.
- De-rate Power Dissipation (Pd) depending on Ambient temperature (Ta). When used in sealed area, confirm the actual ambient temperature.
- Confirm that operation temperature is within the specified range described in the product specification.
- ROHM shall not be in any way responsible or liable for failure induced under deviant condition from what is defined in this document.

Precaution for Mounting / Circuit board design

- When a highly active halogenous (chlorine, bromine, etc.) flux is used, the residue of flux may negatively affect product performance and reliability.
- In principle, the reflow soldering method must be used; if flow soldering method is preferred, please consult with the ROHM representative in advance.

For details, please refer to ROHM Mounting specification

Precautions Regarding Application Examples and External Circuits

1. If change is made to the constant of an external circuit, please allow a sufficient margin considering variations of the characteristics of the Products and external components, including transient characteristics, as well as static characteristics.
2. You agree that application notes, reference designs, and associated data and information contained in this document are presented only as guidance for Products use. Therefore, in case you use such information, you are solely responsible for it and you must exercise your own independent verification and judgment in the use of such information contained in this document. ROHM shall not be in any way responsible or liable for any damages, expenses or losses incurred by you or third parties arising from the use of such information.

Precaution for Electrostatic

This Product is electrostatic sensitive product, which may be damaged due to electrostatic discharge. Please take proper caution in your manufacturing process and storage so that voltage exceeding the Products maximum rating will not be applied to Products. Please take special care under dry condition (e.g. Grounding of human body / equipment / solder iron, isolation from charged objects, setting of ionizer, friction prevention and temperature / humidity control).

Precaution for Storage / Transportation

1. Product performance and soldered connections may deteriorate if the Products are stored in the places where:
 - [a] the Products are exposed to sea winds or corrosive gases, including Cl₂, H₂S, NH₃, SO₂, and NO₂
 - [b] the temperature or humidity exceeds those recommended by ROHM
 - [c] the Products are exposed to direct sunshine or condensation
 - [d] the Products are exposed to high Electrostatic
2. Even under ROHM recommended storage condition, solderability of products out of recommended storage time period may be degraded. It is strongly recommended to confirm solderability before using Products of which storage time is exceeding the recommended storage time period.
3. Store / transport cartons in the correct direction, which is indicated on a carton with a symbol. Otherwise bent leads may occur due to excessive stress applied when dropping of a carton.
4. Use Products within the specified time after opening a humidity barrier bag. Baking is required before using Products of which storage time is exceeding the recommended storage time period.

Precaution for Product Label

QR code printed on ROHM Products label is for ROHM's internal use only.

Precaution for Disposition

When disposing Products please dispose them properly using an authorized industry waste company.

Precaution for Foreign Exchange and Foreign Trade act

Since our Products might fall under controlled goods prescribed by the applicable foreign exchange and foreign trade act, please consult with ROHM representative in case of export.

Precaution Regarding Intellectual Property Rights

1. All information and data including but not limited to application example contained in this document is for reference only. ROHM does not warrant that foregoing information or data will not infringe any intellectual property rights or any other rights of any third party regarding such information or data. ROHM shall not be in any way responsible or liable for infringement of any intellectual property rights or other damages arising from use of such information or data.:
2. No license, expressly or implied, is granted hereby under any intellectual property rights or other rights of ROHM or any third parties with respect to the information contained in this document.

Other Precaution

1. This document may not be reprinted or reproduced, in whole or in part, without prior written consent of ROHM.
2. The Products may not be disassembled, converted, modified, reproduced or otherwise changed without prior written consent of ROHM.
3. In no event shall you use in any way whatsoever the Products and the related technical information contained in the Products or this document for any military purposes, including but not limited to, the development of mass-destruction weapons.
4. The proper names of companies or products described in this document are trademarks or registered trademarks of ROHM, its affiliated companies or third parties.

General Precaution

1. Before you use our Products, you are requested to carefully read this document and fully understand its contents. ROHM shall not be in any way responsible or liable for failure, malfunction or accident arising from the use of any ROHM's Products against warning, caution or note contained in this document.
2. All information contained in this document is current as of the issuing date and subject to change without any prior notice. Before purchasing or using ROHM's Products, please confirm the latest information with a ROHM sales representative.
3. The information contained in this document is provided on an "as is" basis and ROHM does not warrant that all information contained in this document is accurate and/or error-free. ROHM shall not be in any way responsible or liable for any damages, expenses or losses incurred by you or third parties resulting from inaccuracy or errors of or concerning such information.

Mouser Electronics

Authorized Distributor

Click to View Pricing, Inventory, Delivery & Lifecycle Information:

[ROHM Semiconductor:](#)

[BU4551BFV-E2](#)



Компания «ЭлектроПласт» предлагает заключение долгосрочных отношений при поставках импортных электронных компонентов на взаимовыгодных условиях!

Наши преимущества:

- Оперативные поставки широкого спектра электронных компонентов отечественного и импортного производства напрямую от производителей и с крупнейших мировых складов;
- Поставка более 17-ти миллионов наименований электронных компонентов;
- Поставка сложных, дефицитных, либо снятых с производства позиций;
- Оперативные сроки поставки под заказ (от 5 рабочих дней);
- Экспресс доставка в любую точку России;
- Техническая поддержка проекта, помощь в подборе аналогов, поставка прототипов;
- Система менеджмента качества сертифицирована по Международному стандарту ISO 9001;
- Лицензия ФСБ на осуществление работ с использованием сведений, составляющих государственную тайну;
- Поставка специализированных компонентов (Xilinx, Altera, Analog Devices, Intersil, Interpoint, Microsemi, Aeroflex, Peregrine, Syfer, Eurofarad, Texas Instrument, Miteq, Cobham, E2V, MA-COM, Hittite, Mini-Circuits, General Dynamics и др.);

Помимо этого, одним из направлений компании «ЭлектроПласт» является направление «Источники питания». Мы предлагаем Вам помощь Конструкторского отдела:

- Подбор оптимального решения, техническое обоснование при выборе компонента;
- Подбор аналогов;
- Консультации по применению компонента;
- Поставка образцов и прототипов;
- Техническая поддержка проекта;
- Защита от снятия компонента с производства.

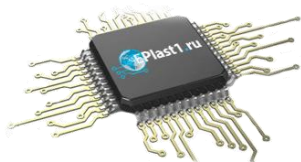

Как с нами связаться

Телефон: 8 (812) 309 58 32 (многоканальный)

Факс: 8 (812) 320-02-42

Электронная почта: org@eplast1.ru

Адрес: 198099, г. Санкт-Петербург, ул. Калинина, дом 2, корпус 4, литера А.