

Miniature Smart RF Transceiv-

Features

- Intelligent Wire replacement SMARTRADIO
- form factor: 16mm x 18mm
- 2Km range
- Transmit Power +13dBm
- High sensitivity -116dBm (@ 2.4kbps)
- Max data rate @ 500Kbps
- Simple UART and SPI interface
- Full CRC Error Checking Option
- User Selectable Data Payload
- Best in Class cost performance
- Available as 433/868/915MHz
- 1.8V – 3.6V Operating Voltage
- Low power consumption
 - 0.5nA Standby
 - 10mA Rx
 - 18mA Tx @ 10dBm
- 64 byte Buffer (FIFO)
- Integrated battery voltage sensor
- Based on Silicon Labs' Si4455 chipset
- No configuration necessary
- No external components
- Fast and effective Plug and Play RF Comms

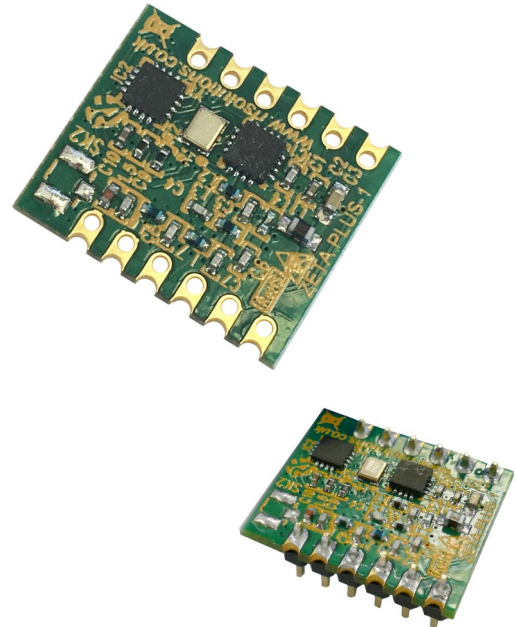

Applications

- Home automation
- Sensor / mesh RF networks
- Telemetry
- Keyless entry
- Health monitors
- RF Data comms

Applications

ZETAPLUS makes a radio data link easy. It has a simple interface using either SPI or UART (LV RS232) and provides a plug 'n' play RF comms to any application.

With connection to power, comms and antenna, the user can start sending and receiving data immediately. No other external components are required.

With a highly tuned on-board RF matching network ZETAPLUS outperforms other modules achieving range far in excess of its competitors for the given power output/power consumption.

Pin Description

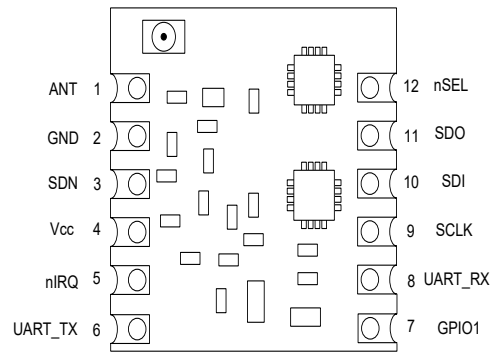

PIN	Name	Definition	Data Flow	Function
1	ANT	Antenna Pin	In/Out	Antenna pin connection. Keep track to antenna short and impedance match to 50ohms for best performance
2	GND	Ground	In	Supply Ground connection
3	SDN	Shutdown	In	When asserted (active High) ZETAPLUS enters Shutdown. Shutdown state is the lowest current consumption of the device. Settings will be retained when SDN is asserted. When shutdown is activated no comms are possible as the device is in deep sleep mode. The time between taking the shutdown pin low and a command being excepted varies depending on supply, crystal etc and can range from 10-25ms. ZETAPLUS is ready for commands when the nIRQ pin goes high. There can be up to 2ms after the shutdown pin has gone low where the nIRQ pin is in an unknown state so always give 2ms after lowering the shutdown pin
4	Vcc	V Supply	In	Supply Voltage Connection
5	nIRQ	Interrupt	Output	Active Low Data packet received in SPI RX mode only
6	UART_TX	UART Transmit	Out	UART (LV RS232) Data appears on this output
7	GPIO1	Gen Purpose I/O	In / Out	This is not yet implemented
8	UART_RX	UART Receive	In	RS232 Receive Pin
9	SCLK	Serial clock	In	SPI Clock In
10	SDI	Serial data In	In	SPI Data In
11	SDO	Serial data Out	Out	SPI Data Out
12	nSEL	Serial interface select	In	SPI Device Select (Active Low) Only used in SPI mode is SPI not used pull high or leave disconnected

Ordering information

Part Number	Description
ZETAPLUS-433-SO	FM transceiver module, 433MHz (marked Red Dot) SMT
ZETAPLUS-433-D	FM transceiver module, 433MHz (marked Red Dot) DIP
ZETAPLUS-868-SO	FM transceiver module, 868MHz (marked Blue Dot) SMT
ZETAPLUS-868-D	FM transceiver module, 868MHz (marked Blue Dot) DIP
ZETAPLUS-915-SO	FM transceiver module 915MHz (marked Yellow Dot) SMT
ZETAPLUS-915-D	FM transceiver module 915MHz (marked Yellow Dot) DIP

Block Diagram

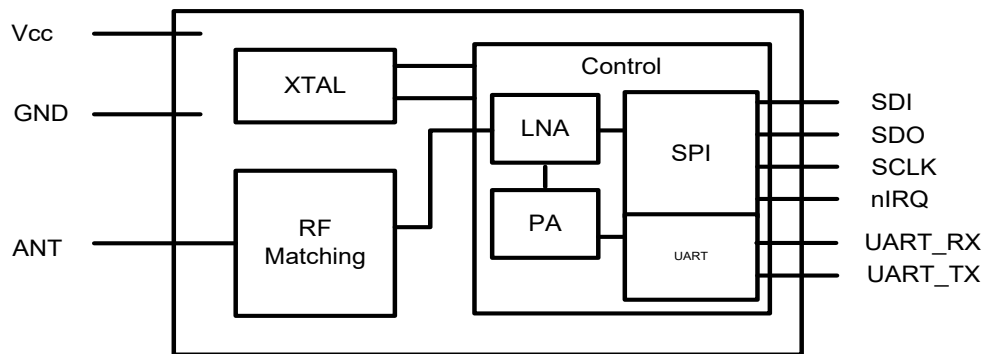

Using ZETAPLUS

Using ZETAPLUS is easy, communication can be via SPI interface or UART (LVTTTL).

The module will automatically communicate to its host in the same way that it was addressed, i.e. if ZETAPLUS receives communications on its SPI interface, then it will reply on the SPI. If comms was last received on the UART interface then it will replay on the UART interface.

Using SPI, to Transmit data simply load the correct decimal byte values into the SPI TX register.

When ZETAPLUS receives RF data from another ZETAPLUS module it will output this using SPI, the nIRQ line will be pulled low, this shows that data will be ready to be read from the SPI register to the host

Using UART (LVTTTL) to Transmit load the correct decimal byte values into the UART TX register,

When ZETAPLUS receives RF data from another ZETAPLUS module it will output the data via the UART-TX output pin of the module to the host. (This operates as a standard UART)

Application schematic- ZETAPLUS and PIC16F886 (SPI mode)

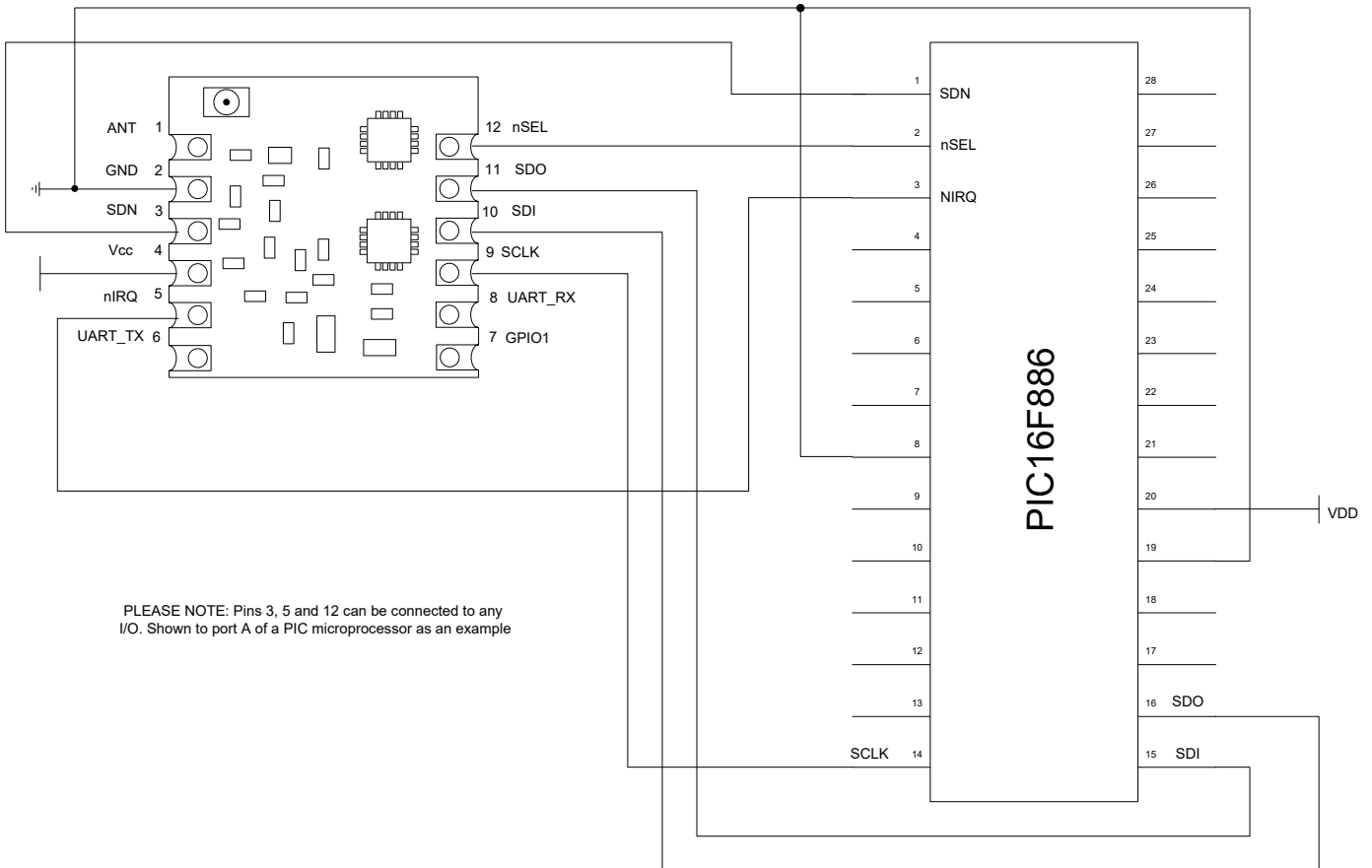

Application schematic- ZETAPLUS and PIC16F886 (UART)

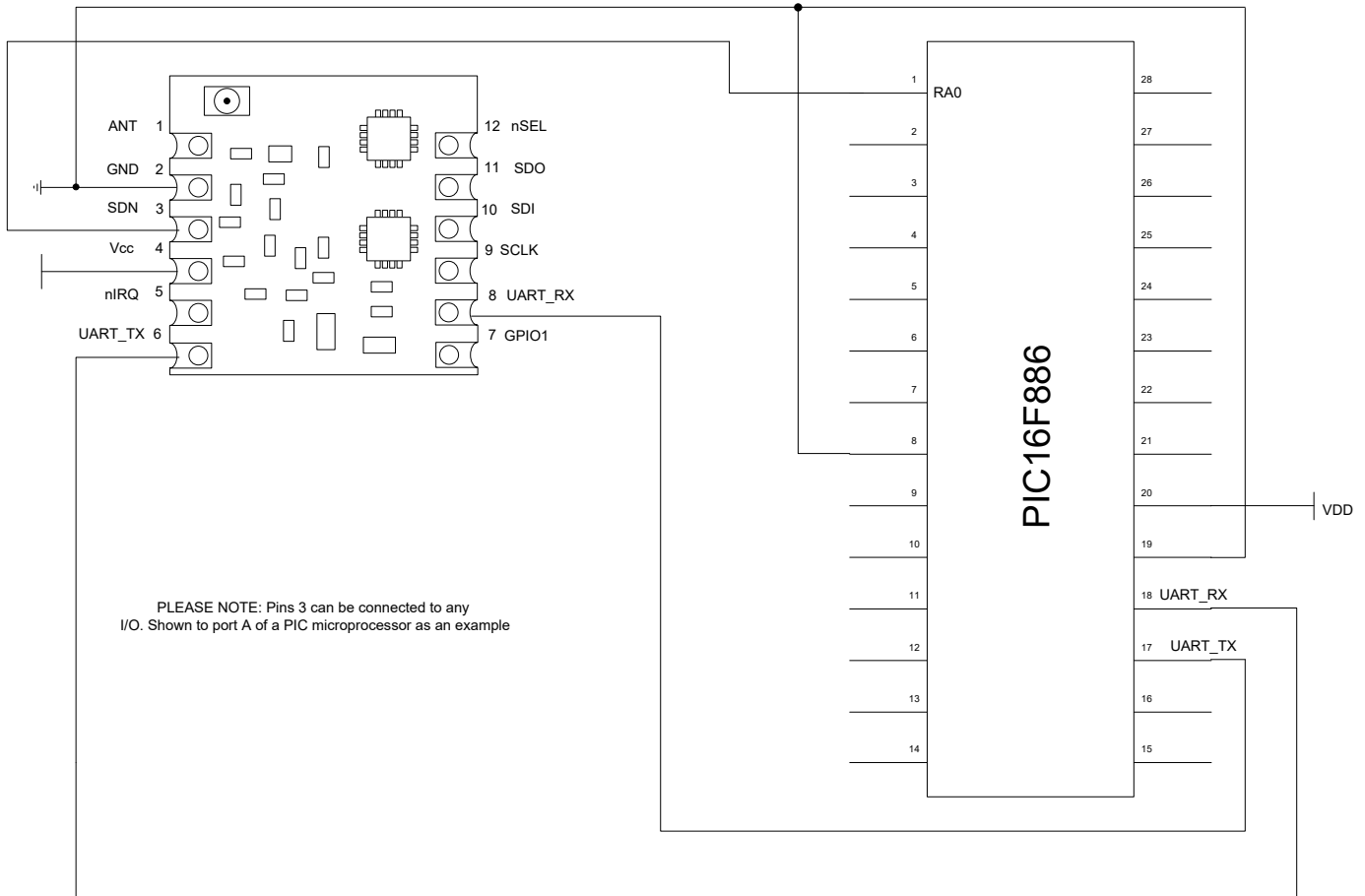

UART configuration

UART configuration:

Baud rate: 19200, Data bits: 8, Parity: none, Stop bits: 1

Note all UART I/O are at Low level and must not exceed 5V.

UART in

Data is sent to the RX pin on the ZETAPLUS n standard UART format using the correct command set. A 50ms timeout exists to avoid lock-up if not all requested data bytes are sent - in this scenario the packet would be aborted and no data sent.

UART out

Data is output from the TX pin on the ZETAPLUS.

When in receive mode and an RF packet is received the data packet is automatically send over the UART and output as #RnQ 'data' where n is the number of bytes.

SPI and UART Commands

Operating Mode (ATM)

Note: after SDN is pulled low this setting will need to be resent as module defaults to ready state.

Value	Name	Description
1	RX	ZETAPLUS enters RX mode using last RX configured settings
2 (default)	Ready	Ready is a low power awake state which can be used for fast entry to RX or switching between TX and RX. Time to RX or TX from READY < 1ms
3	Sleep	Low power sleep mode with register retention.

Example: Place the ZETAPLUS into receive mode

Note: alternative possible example of mode select for some terminal programs: ATM#001.

Command	A	T	M	1
Decimal byte value	65	84	77	1

Receive Mode Config (ATR) Channel Setting, Packet Length

Note: after SDN is pulled low this setting will need to be resent as module defaults to ready state.

Value	Name	Description
0-15	Channel	Set in 250KHz increments starting at (FREQ dependent): At 433MHz: 0=433.92 At 868MHz: 0=869.50 At 915MHz: 0=915
1-65	Packet Length	Length of data packet to be sent in 8 bit bytes

Example: Enter receiver mode on channel 2 with a packet length of 10 bytes.

Command	A	T	R	2	10
Decimal byte value	65	84	82	2	10

Note

When a valid packet is received in SPI mode the U_IRQ pin will go low indicating data is ready to be read over SPI.

When a valid packet is received in UART mode the data is immediately sent via the U_LVTTL TX pin.

Transmit Mode Config: (ATS) CHANNEL, PACKET LENGTH, DATA

Value	Name	Description
0-15	Channel	Set in 250KHz increments starting at (FREQ dependent): At 433MHz: 0=433.92 At 868MHz: 0=869.50 At 915MHz: 0=915
1-64	Packet length	This defines the data payload. In 8 bit bytes.
	Data	Your data to be transmitted. ZETAPLUS will then return to the state it was in prior to ATS command.

Example: send a 13 byte packet on channel 2

Command	A	T	S	2	13	DATA
Decimal byte value	65	84	83	2	13	Your 13 bytes

Note: You can send a packet from any mode and after a packet has been transmitted the module will revert back to the mode it was previously in.

Sync bytes (ATA) SYNC1, SYNC2, SYNC3, SYNC4

Value	Name	Description
1-4	SYNC1-4	The sync bytes appear directly after the pre-amble in the transmitted RF data. They can be used as a form of addressing to discriminate between valid and spurious data. Set these bytes and the ZETAPLUS will only pass on data which contains the correct sync bytes. Set all to AA if not required. (the module will act as a simple pass thro and will require the user to determine their own SYNC) NOTE: Reverse order bytes: ie 2D = D4, D4 =2B

Default :SYNC BYTE 1 : 0XB4 SYNC BYTE: 2 0X1B SYNC BYTE 3: 0X00 SYNC BYTE 4: 0X00.

Example: Set the sync bytes to 12 34 56

Command	A	T	A	12	34	56	78
Decimal byte value	65	84	65	12	34	56	78

Enable Data Error Checking (ATE)

Value	Name	Description
0 - 1	CRC Error Check	Enables CRC Error Checking of Received data and only passes valid data to the host. 0 =Disable Error Checking (Power on Default Value) 1 =Enable Error Checking

Example: Enable RF Error Checking

Command A T E 1
Decimal byte value 65 84 69 1

Enable Response (ATC)

Value	Name	Description
0 - 1	Response on	Enables Response +=good -=error 0 =Disable Response (Power on Default Value) 1 =Enable Response

Example: Enable RESPONSE

Command A T C 1
Decimal byte value 65 84 67 1

Note: When enabled you will receive a response of either + or - after each command has completed. +=Completed successfully and ready for the next command. -=The last command didn't complete due to a syntax error but the module is ready for the next command.

RSSI (ATQ)

Value	Name	Description
0—255	RF Signal Strength	ZETAPLUS responds with the Received Signal Strength Value. Example reply: 35 81 56 #Q followed by one byte RSSI value (0-255)

Example: Retrieve settings

Command A T Q
Decimal byte value 65 84 81

Retrieve Current Configuration and Settings (AT?)

Value	Name	Description
N/A	Configuration and settings	<p>ZETAPLUS Reports its current device settings</p> <p>Example reply:</p> <pre>#? FOLLOWED BY 8 BYTE AS BELOW OPERATING MODE (MODE:- 1= RX 2=READY) RF BAUD RATE (1-19) RF POWER OP (1-127) SYNC BYTE 1 SYNC BYTE 2 SYNC BYTE 3 SYNC BYTE 4 CHANNEL NUMBER (0-15)</pre> <p>EXAMPLE 35 63 1 1 127 45 210 0 0 0</p>

Example: Retrieve settings

Command	A	T	?
Decimal byte value	65	84	63

Firmware Version

Command	Name	Description
N/A	Firmware Version	<p>Use this command to determine the firmware version of the ZETAPLUS-PLUS module .</p> <p>Example reply: # V 1 . 0 0</p> <p>EXAMPLE 35 86 31 46 30 30</p>

Example: Check firmware version

Command	A	T	V
Decimal byte value	65	84	86

Reset to Power On Defaults (ATD)

Command	Name	Description
N/A	Firmware Version	Resets the configuration of ZETAPLUS Power On Status

Example:

Command	A	T	D
Decimal byte value	65	84	68

Ping-Pong (Walk test)

Using two ZETAPLUS module a test signal can be sent to 'Ping' 'Pong' between the two providing a site check of signal strength for a specific application.

In this mode one ZETAPLUS transmits a special 'Ping' signal, which is received by another ZETAPLUS module which outputs the message #RZYXWVUTSRQ (#R followed by the last 10 letters of the alphabet in reverse) to its host, and then automatically reply's back the 'Pong' message.

The originating ZETAPLUS module receives back the 'Pong' and outputs #T followed by the received Signal Strength Indication (RSSI) value.

If no 'Pong' reply packet is received back from the receiver within 200ms the RSSI value will be 0.

TRANSMITTER

The example below sets the ZETAPLUS to transmit a ping signal.

The transmitter will output every 200ms the RSSI value of of a valid packet through its UART RX pin.

ATT#000



Channel number (byte value)

The below screen shots shows a terminal window and the received data on the RX pin. The image shows the data packet that is output when a successful ping-pong takes place on the transmitter.

The below image shows the values output by the transmitter during the walk test when no packet is received back from the receiver.

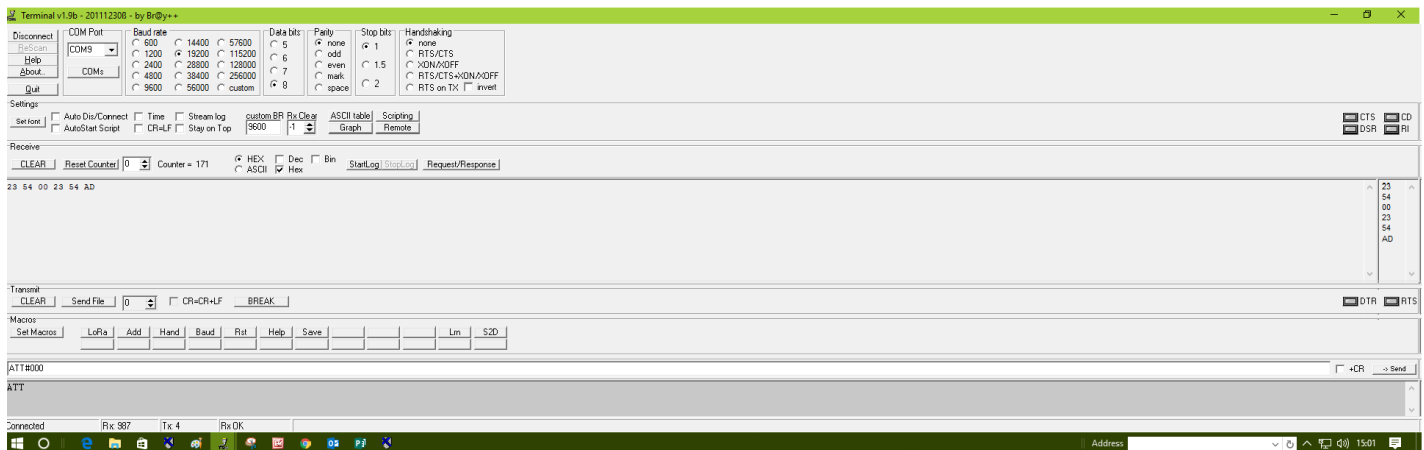

RECEIVER

To configure the ZETAPLUS into receiver mode for the ping-pong walk test, the following string needs to be input on the TX pin.

ATR#000#010

Channel number (byte value)

10 byte payload (this is the only byte value that will force the ZETAPLUS into ping-pong)

The image below shows a terminal window with a successful packet received, here you can see the HEX values for #RZYXWVUTSRQ.

#R is the packet header which indicates the start of a new packet

Followed by the bytes received as a byte value

Followed by the received signal strength as a byte value.

Followed by the data sent from the transmitter.

For example on the TX side if ATS<0><10>ABCDEFGHIJ was issued you would receive

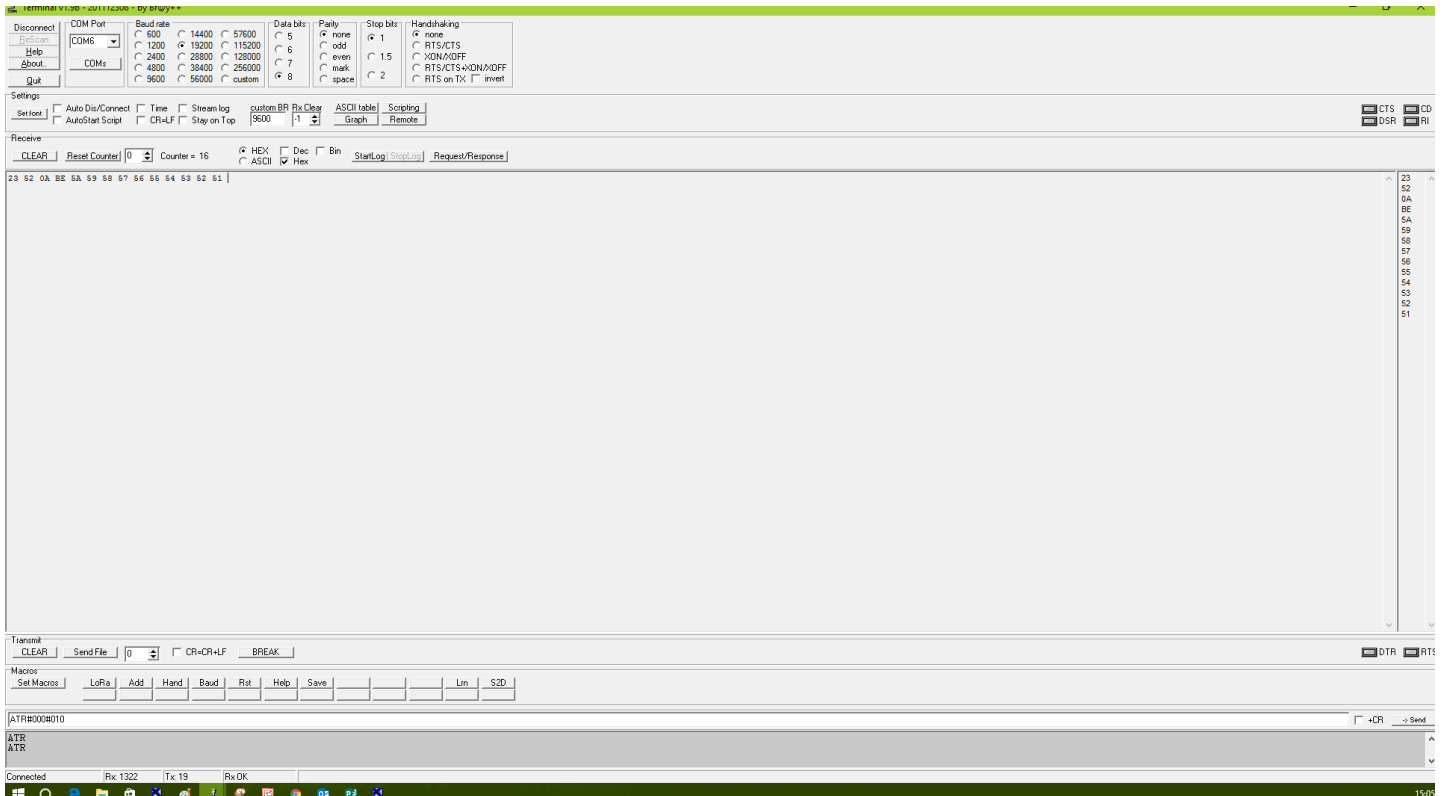

Communication with the ZETAPLUS via SPI interface.

Maximum SPI data rate: 1.4Mhz

Data is sent over the SPI bus on the ZETAPLUS codec in standard SPI format using the correct command set. A 50ms timeout exists to avoid lock-up if not all requested data bytes are sent - in this scenario the packet would be aborted and no data sent.

When in receive mode and an RF packet is received the U_IRQ pin will go low indicating SPI data is ready to be read.

The following two pages show example timing diagrams for the SPI bus communication.

Selecting preferred communication method.

Only one communication method can be used at a time. Switching from SPI to UART and vice versa is possible however please note that ZETAPLUS will respond using the comms that it was last addressed in.

For example if you enable receive mode via SPI ZETAPLUS will revert to SPI communication from there on unless you access the device via UART ZETAPLUS will then revert to UART communication from then on.

MSO-X 2012A, MY51360370: Thu Jul 30 18:54:22 2015



Above is the first byte of SPI data following U_IRQ going low after an RF packet has been received.

Sequence:-

1. IRQ goes low indicating a packet has been received.
2. Read byte over SPI bus.
3. If IRQ remains low then more data is still available to read. Repeat line 2 above.

The first two bytes read should be #R followed by the packet length & RSSI value then the packet data.

ZETAPLUS Smart RF Transceiver



MSO-X 2012A, MY51360370: Thu Jul 30 18:55:05 2015



Above is the complete SPI & IRQ Timing diagram for #R<RSSI> <Packet > plus 12 byte data packet

Mechanical dimensions

Surface Mount Package

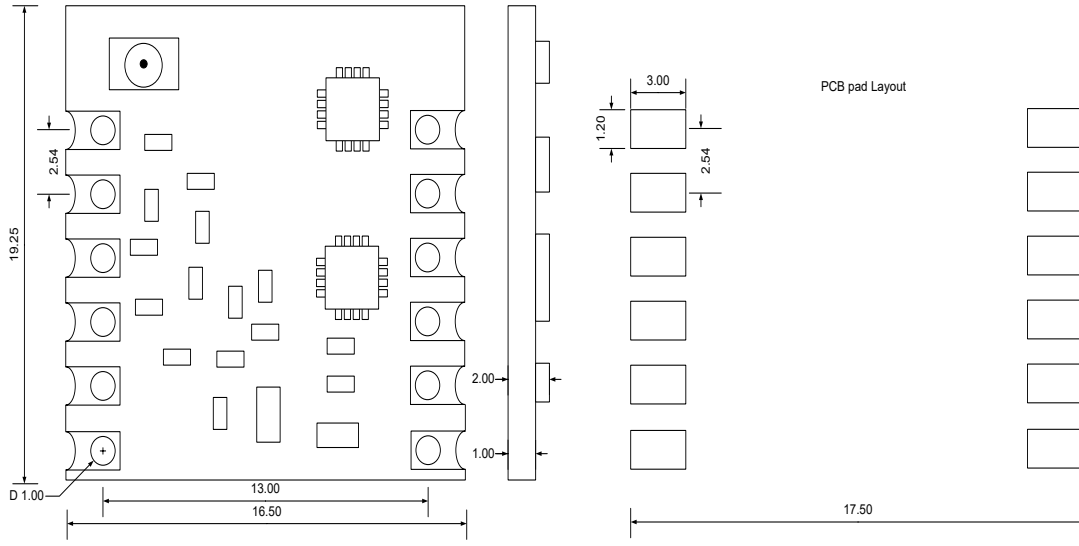

P-DIP Package

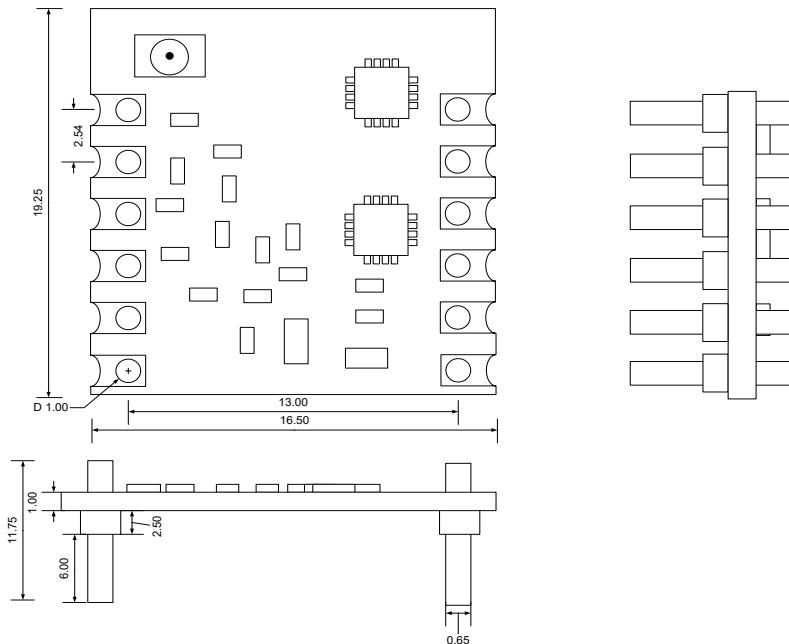

Electrical Characteristics

Recommended operating conditions

Parameter	Symbol	Test condition	Min	Typ.	Max	Unit
Ambient Temperature	T_A		-40	25	85	°C
Supply Voltage	V_{DD}		1.8		3.6	V
I/O Drive Voltage	V_{GPIO}		1.8		3.6	V

Parameter	Symbol	Test condition	Min	Typ.	Max	Unit
Supply voltage range	V_{CC}		1.8	3.3	3.6	V
Power saving modes	I_{ready}	Ready to receive instruction from host	—	6	—	mA
	I_{Sleep}	Module asleep with shutdown pin active.	—		<1	uA
RX mode current	I_{RX}	Module is in RF Data receive mode	—	16	—	mA
TX mode current	I_{TX}	+10 dBm output power, 868 MHz	—	19	—	mA
		+13 dBm output power, 868 MHz	—	24	—	mA

Important European compliance information for module datasheets

This RF Solutions radio module meets the essential requirements of the European Radio Equipment Directive 2014/53/EU and has been tested to European Harmonised Standards and CE marked where space allows. A copy of the EU Declaration of Conformity can be located on the RF Solutions Website, www.rfsolutions.co.uk/certification-i59.

When using the module in an end product, continued compliance can only be assured by incorporating the module in accordance with RF Solutions specific installation instructions and in accordance with the published information on the RF Solutions product data sheet. The antenna gain specification must be adhered to at all times.

Article 3.1a and 3.1b of the EU Radio Equipment Directive 2014/53/EU should be assessed in the final product.

Failure to follow this guidance may result in a non-compliant product being placed on the European Market, for which RF Solutions cannot accept any responsibility.

Further guidance may be obtained from RF Solutions Technical Support. Charges may apply to customer specific product evaluation.

ZETAPLUS Smart RF Transceiver



AC Characteristics

Parameter	Symbol	Test condition	Min	Typ	Max	Unit
TX frequency range	F_{TX}			433.9 2 869.5 915.0	+25 0KHz (x16)	MHz
(G)FSK data rate	DR_{FSK}		4.8	—	500	kbps
TX Output power range	P_{TX}		-40	—	+13	dBm
TX RF output level variation vs. temperature	DP_{RF_TEMP}	-40 to +85 °C	—	1	—	dB
TX RF output level Variation vs. frequency	DP_{RF_FREQ}	Measured across 850-870 MHz	—	0.5	—	dB
Transmit modulation filtering	$B*T$	Gaussian filtering bandwidth time product	—	0.5	—	
Spurious emissions	P_{OB-TX1}	$P_{OUT} = +13$ dBm, Frequencies < 1 GHz	—	-54	—	dBm
	P_{OB-TX2}	1-12.75 GHz, excluding harmonics	—	-42	—	dBm
Harmonics	$P2_{HARM}$	Using reference design TX matching network & filter with max O/P power. Harmonics reduce linearly with	—	-42	—	dBm
	$P3_{HARM}$		—	-42	—	dBm
RX sensitivity	P_{RX_2}	(BER < 0.1%) (2.4 kbps, GFSK, BT = 0.5, DF = ±30 kHz, 114 kHz Rx BW)	—	-116	—	dBm
	P_{RX_40}	(BER < 0.1%) (40 kbps, GFSK, BT = 0.5, DF = ±25 kHz, 114 kHz Rx BW)	—	-108	—	dBm
	P_{RX_128}	(BER < 0.1%) (128 kbps, GFSK, BT = 0.5, DF = ±70 kHz, 305 kHz Rx BW)	—	-103	—	dBm
	P_{RX_OOK}	(BER < 0.1%, 1 kbps, 185 kHz Rx BW, OOK, PN15 data)	—	-113	—	dBm
		(BER < 0.1%, 40 kbps, 185 kHz Rx BW, OOK, PN15 data)	—	-102	—	dBm
RX channel bandwidth	BW			60		kHz
BER variation vs power Level2	P_{RX_RES}	Up to +5 dBm Input Level	—	0	0.1	ppm
Blocking 200 kHz-1 MHz	$200K_{BLOCK}$	Desired ref signal 3 dB above sensitivity, BER < 0.1%. Interferer is CW and desired modulated with 1.2 kbps DF = 5.2 kHz GFSK with BT = 0.5, RX BW = 58 kHz	—	-58	—	dB
Blocking 1 MHz offset	$1M_{BLOCK}$		—	-61	—	dB
Blocking 8 MHz offset	$8M_{BLOCK}$		—	-79	—	dB
Image rejection	Im_{REJ}	Rejection at the image frequency IF = 468 kHz	—	-35	—	dB
Spurious emissions	P_{OB_RX1}	Measured at RX pins	—	-54	—	dBm

ZETAPLUS module re-flow guide

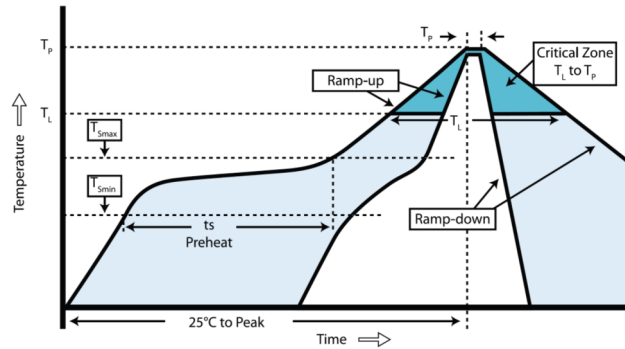

Profile feature	Value (lead free)
Ramp up rate	3°C /s
Pre-heat temperature	
- Temperature Min (T _{smmin})	150°C
- Temperature Max (T _{smmax})	200°C
- Pre-heat time	60-100s
Peak temperature (T _p)	240°C
Time at T _p	10-20sec
Ramp down rate	6°C/s
Time from 25°C to peak	8 mins max.

ZETAPLUS Smart RF Transceiver



ZETAPLUS module Version Identification

Frequency of Operation
 Red 433MHz
 Blue 868MHz
 Brown 915MHz

Test
 Green Pass

Firmware Version

Firmware versions Uses std Colour Coding	
Colour Dot	Rev
Brown	1
Red	2
Orange	3
Yellow	4
Green	5
Blue	6
Violet	7
Grey	8
White	9

ZETAPLUS REVISION CHANGE HISTORY

Part	New Revision	Change / Fix
ZETAPLUS-433 ZETAPLUS-868	2 2	Shut down pin fixed
ZETAPLUS-433 ZETAPLUS-868 ZETAPLUS-915	3 3 3	Module would default to max power mode on power-up, regardless of user settings . After module was shutdown, when re-initialised the module would sometimes start in the wrong frequency . In addition the following new Commands have been added. ATD, (Reset to Defaults) ATE, (CRC Error Checking) ATH (host interface Baud Rate)
ZETAPLUS-433 ZETAPLUS-868 ZETAPLUS-915	4 4 4	On wakeup the SPI configuration was left as 3 wire config so CS input not activated, this has been updated to 4 wire Config In addition the following new Commands have been added. ATC, (Enable Response)
ZETAPLUS-433 ZETAPLUS-868 ZETAPLUS-915	5 5 5	To accommodate SiLabs Si4455 Silicon Revision Change from B to C
ZETAPLUS-433 ZETAPLUS-868 ZETAPLUS-915	6 6 6	Improvement to initial power on cycle preventing the Shutdown pin from being misread

ZETAPLUS Smart RF Transceiver



Range Test

Two Transceiver boards were built using simple prototyping board and a host PIC microcontroller . One board was programmed as a transmitter to send a beacon signal at 1 second interval. The other board was programmed as receiver which acknowledged the received signal back to the transmitter thus creating a ping-pong test set.

A simple piece of wire was used as antenna for both boards

Prototyping board and wire as antenna is not ideal, but many real applications are often a compromise!

i.e. the antenna was not 100% ideal, there was no antenna ground plane, the motherboard was rudimentary.

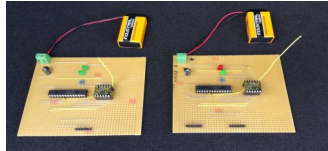

Our Range Testing was conducted from Ditchling Beacon providing an open Line of Sight Test.

1. The Transmitter was placed Receiver was mounted on the back of a pick up truck and the receiver was carried by hand ~5ft from the ground .
2. As the receiver travelled away from the transmitter Line of sight was occasionally lost when we went in the shadow of a hill, at this time the RF signal was intermittent, A Reliable signal in Line of sight was observed to 2.4K range, thereafter we couldn't go any further as the pathway stopped. At this range in L.O.S the signal was 100% reliable.

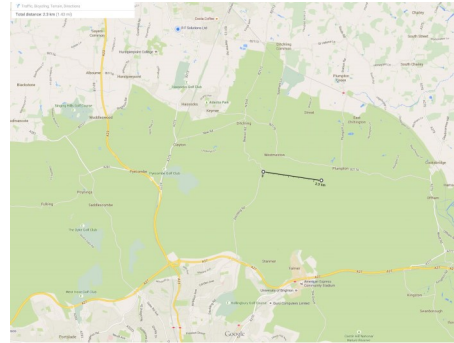

Test conditions

- $T_A = +18\text{ }^\circ\text{C}$
- $V_{DD} = +3.3\text{ Vdc}$
- Dry, Broken Sunshine, Relative Humidity 45%

Result:

The test achieve a maximum range of 2.4km after this point the terrain dropped away and a line of sight was completely lost, it is possible that the module may have achieved a longer range.



RF Solutions Ltd. Recycling Notice

Meets the following EC Directives:

DO NOT

Discard with normal waste, please recycle.

ROHS Directive 2002/95/EC

Specifies certain limits for hazardous substances.

WEEE Directive 2002/96/EC

Waste electrical & electronic equipment. This product must be disposed of through a licensed WEEE collection point. RF Solutions Ltd. , fulfils its WEEE obligations by membership of an approved compliance scheme.

Disclaimer:

Whilst the information in this document is believed to be correct at the time of issue, RF Solutions Ltd does not accept any liability whatsoever for its accuracy, adequacy or completeness. No express or implied warranty or representation is given relating to the information contained in this document. RF Solutions Ltd reserves the right to make changes and improvements to the product(s) described herein without notice. Buyers and other users should determine for themselves the suitability of any such information or products for their own particular requirements or specification(s). RF Solutions Ltd shall not be liable for any loss or damage caused as a result of user's own determination of how to deploy or use RF Solutions Ltd's products. Use of RF Solutions Ltd products or components in life support and/or safety applications is not authorised except with express written approval. No licences are created, implicitly or otherwise, under any of RF Solutions Ltd's intellectual property rights. Liability for loss or damage resulting or caused by reliance on the information contained herein or from the use of the product (including liability resulting from negligence or where RF Solutions Ltd was aware of the possibility of such loss or damage arising) is excluded. This will not operate to limit or restrict RF Solutions Ltd's liability for death or personal injury resulting from its negligence.

www.rfsolutions.co.uk

RF Solutions Ltd

William Alexander House, William Way, Burgess Hill, West Sussex, RH15 9AG
Sales: +44(0)1444 227 910 Tech Support: +44(0)1444 227909





Компания «ЭлектроПласт» предлагает заключение долгосрочных отношений при поставках импортных электронных компонентов на взаимовыгодных условиях!

Наши преимущества:

- Оперативные поставки широкого спектра электронных компонентов отечественного и импортного производства напрямую от производителей и с крупнейших мировых складов;
- Поставка более 17-ти миллионов наименований электронных компонентов;
- Поставка сложных, дефицитных, либо снятых с производства позиций;
- Оперативные сроки поставки под заказ (от 5 рабочих дней);
- Экспресс доставка в любую точку России;
- Техническая поддержка проекта, помощь в подборе аналогов, поставка прототипов;
- Система менеджмента качества сертифицирована по Международному стандарту ISO 9001;
- Лицензия ФСБ на осуществление работ с использованием сведений, составляющих государственную тайну;
- Поставка специализированных компонентов (Xilinx, Altera, Analog Devices, Intersil, Interpoint, Microsemi, Aeroflex, Peregrine, Syfer, Eurofarad, Texas Instrument, Miteq, Cobham, E2V, MA-COM, Hittite, Mini-Circuits, General Dynamics и др.);

Помимо этого, одним из направлений компании «ЭлектроПласт» является направление «Источники питания». Мы предлагаем Вам помощь Конструкторского отдела:

- Подбор оптимального решения, техническое обоснование при выборе компонента;
- Подбор аналогов;
- Консультации по применению компонента;
- Поставка образцов и прототипов;
- Техническая поддержка проекта;
- Защита от снятия компонента с производства.



Как с нами связаться

Телефон: 8 (812) 309 58 32 (многоканальный)

Факс: 8 (812) 320-02-42

Электронная почта: org@eplast1.ru

Адрес: 198099, г. Санкт-Петербург, ул. Калинина, дом 2, корпус 4, литера А.