

200-mA 3.3-V or 5.0-V Output LDO Regulators



BD4xxM2-C Series

●General Description

The BD4xxM2-C series are low quiescent regulators featuring 45 V absolute maximum voltage, and output voltage accuracy of $\pm 2\%$ (3.3 V or 5.0 V: Typ.), 200 mA output current and 40 μA (Typ.) current consumption. These regulators are therefore ideal for applications requiring a direct connection to the battery and a low current consumption. A logical "HIGH" at the CTL pin enables the device and "LOW" at the CTL pin not enables the device. (Only W: Includes switch)
Ceramic capacitors can be used for compensation of the output capacitor phase. Furthermore, these ICs also feature overcurrent protection to protect the device from damage caused by short-circuiting and an integrated thermal shutdown to protect the device from overheating at overload conditions.

●Features

- Qualified for Automotive Applications
- Wide Temperature Range: -40 °C to +150 °C
- Wide Operating Input Range: 3.0 V to 42 V
- Low Quiescent Current: 40 μA (Typ.)
- Output Current: 200 mA
- High Output Voltage Accuracy: $\pm 2\%$
- Output Voltage: 3.3 V or 5.0 V (Typ.)
- Enable Input (Only W: Includes Enable Input)
- Over Current Protection (OCP)
- Thermal Shutdown Protection (TSD)
- AEC-Q100 Qualified

●Packages

W (Typ.) x D (Typ.) x H (Max.)

- EFJ: HTSOP-J8 4.90 mm x 6.00 mm x 1.00 mm



- FP3: SOT223-4F 6.53 mm x 7.00 mm x 1.80 mm



Figure 1. Package Outlook

●Applications

- Automotive
(body, audio system, navigation system, etc.)

●Typical Application Circuits

- Components externally connected: $0.1 \mu\text{F} \leq \text{CIN}$, $10 \mu\text{F} \leq \text{COUT}$ (Typ.)
*Electrolytic, Tantalum and Ceramic capacitors can be used.

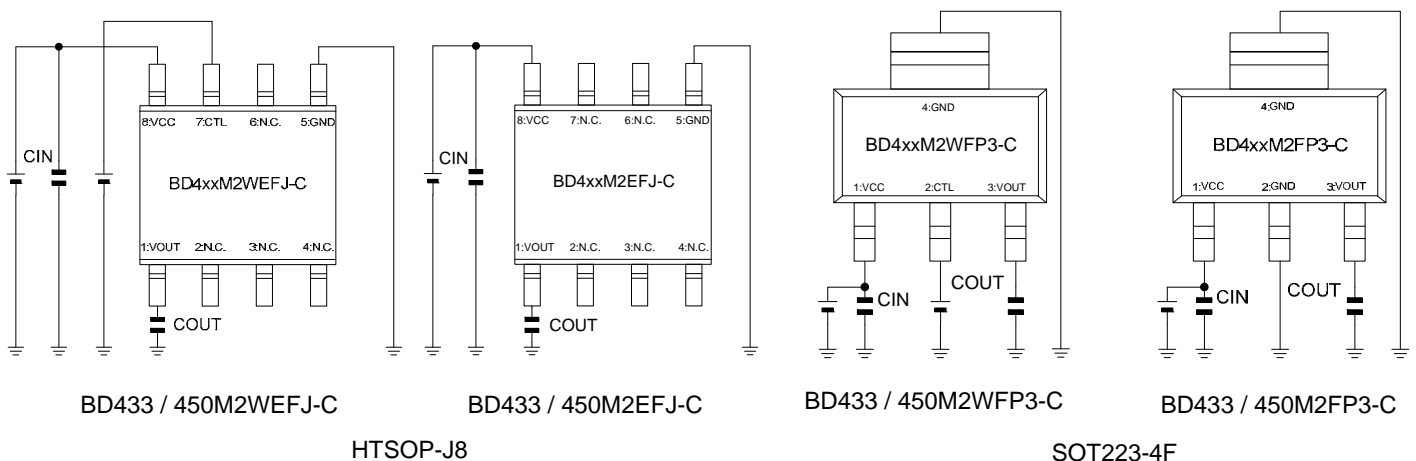
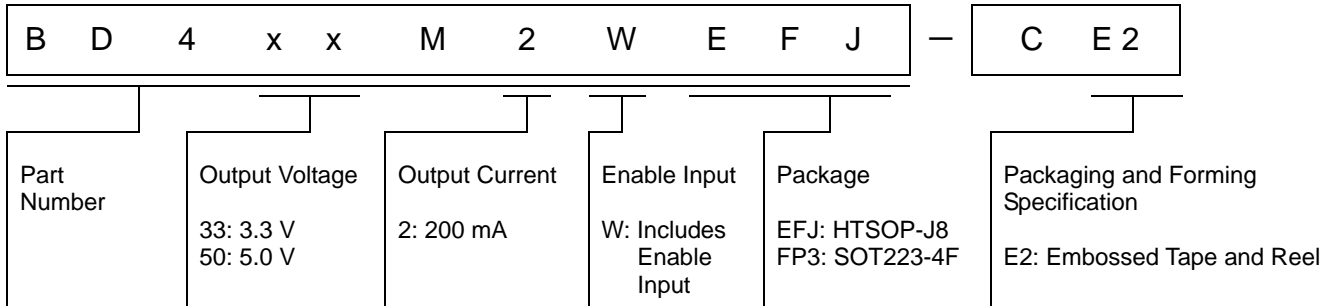

Figure 2. Typical Application Circuits

●Ordering Information



●Lineup

Output Current Ability	Output Voltage (Typ.)	Enable Input *1	Package Type	Orderable Part Number
200 mA	3.3 V	○	SOT223-4F	BD433M2WFP3-CE2
			HTSOP-J8	BD433M2WEFJ-CE2
		—	SOT223-4F	BD433M2FP3-CE2
			HTSOP-J8	BD433M2EFJ-CE2
	5.0 V	○	SOT223-4F	BD450M2WFP3-CE2
			HTSOP-J8	BD450M2WEFJ-CE2
		—	SOT223-4F	BD450M2FP3-CE2
			HTSOP-J8	BD450M2EFJ-CE2

*1 ○: Includes Enable Input.

—: Not includes Enable Input.

● Pin Configurations



Figure 3. Pin Configuration

● Pin Descriptions

■ BD433 / 450M2WEFJ-C

Pin No.	Pin Name	Function
1	VOUT	Output pin
2	N.C.	Not Connected
3	N.C.	Not Connected
4	N.C.	Not Connected
5	GND	Ground Pin
6	N.C.	Not Connected
7	CTL	Output Control Pin
8	VCC	Supply Voltage Input Pin

■ BD433 / 450M2WFP3-C

Pin No.	Pin Name	Function
1	VCC	Supply Voltage Input Pin
2	CTL	Output Control Pin
3	VOUT	Output Pin
4 (FIN)	GND	Ground Pin

■ BD433 / 450M2EFJ-C

Pin No.	Pin Name	Function
1	VOUT	Output Pin
2	N.C.	Not Connected
3	N.C.	Not Connected
4	N.C.	Not Connected
5	GND	Ground Pin
6	N.C.	Not Connected
7	N.C.	Not Connected
8	VCC	Supply Voltage Input Pin

■ BD433 / 450M2FP3-C

Pin No.	Pin Name	Function
1	VCC	Supply Voltage Input Pin
2	GND	Ground Pin
3	VOUT	Output Pin
4 (FIN)	GND	Ground Pin

* N.C. Pin is recommended to short with GND.

* N.C. Pin can be open because it isn't connect it inside of IC.

* Exposed die pad is need to be connected to GND.

●Block Diagrams

■BD433 / 450M2WEFJ-C

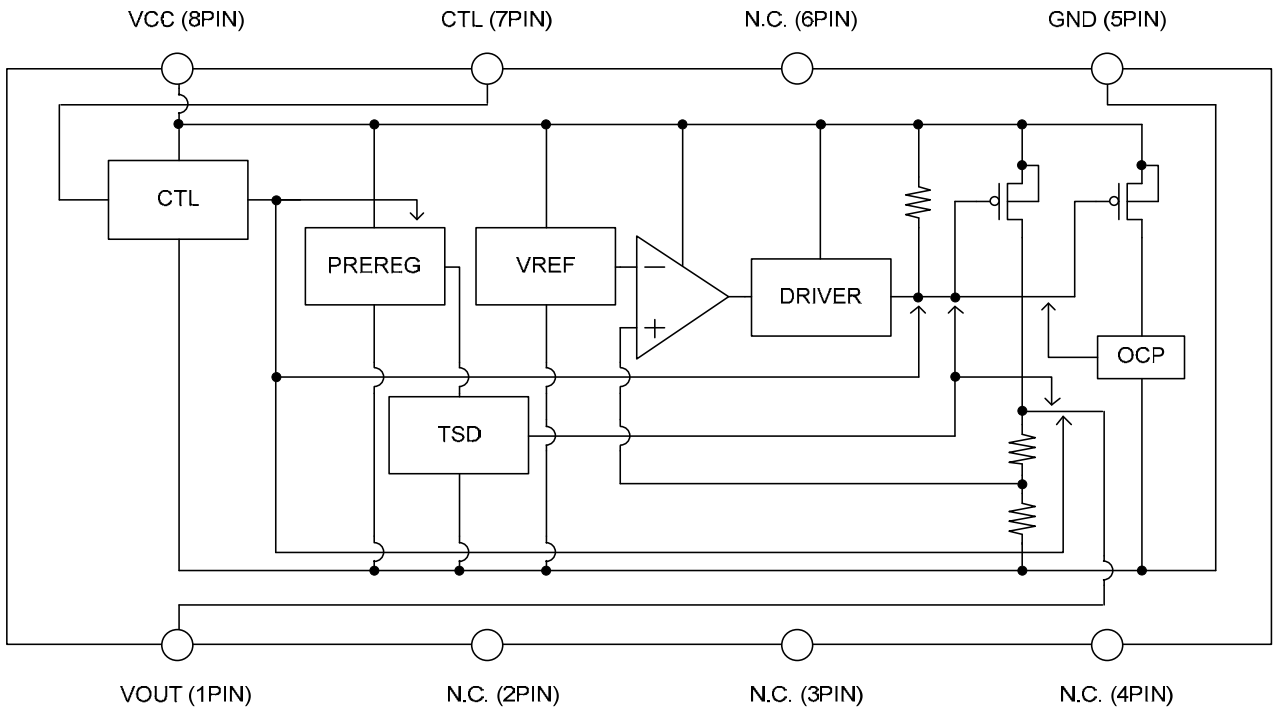

■BD433 / 450M2EFJ-C

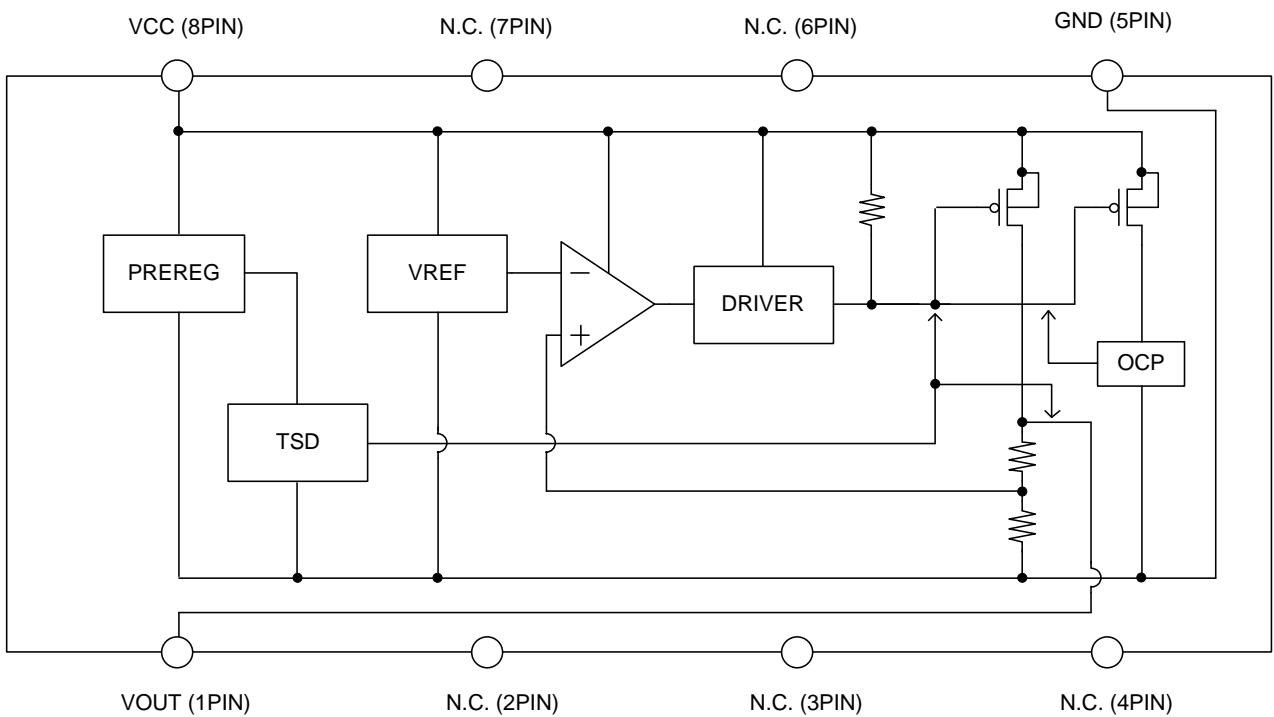

■BD433 / 450M2WFP3-C

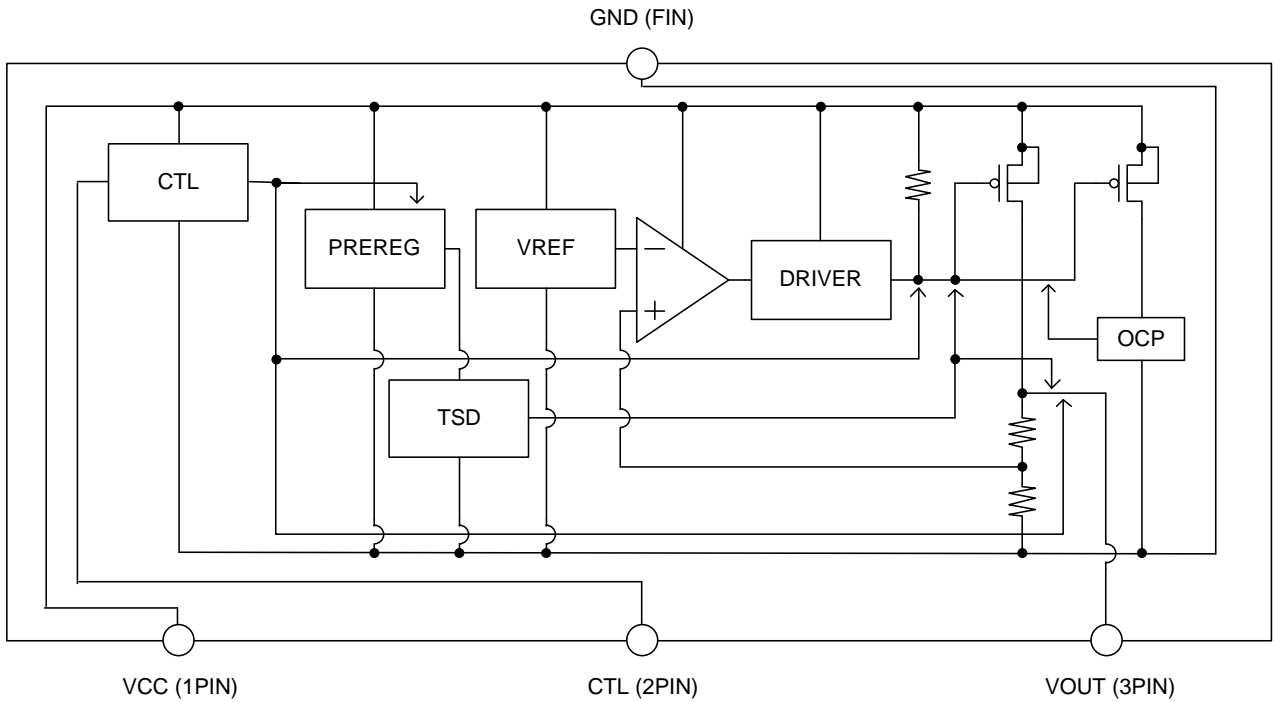

■BD433 / 450M2FP3-C

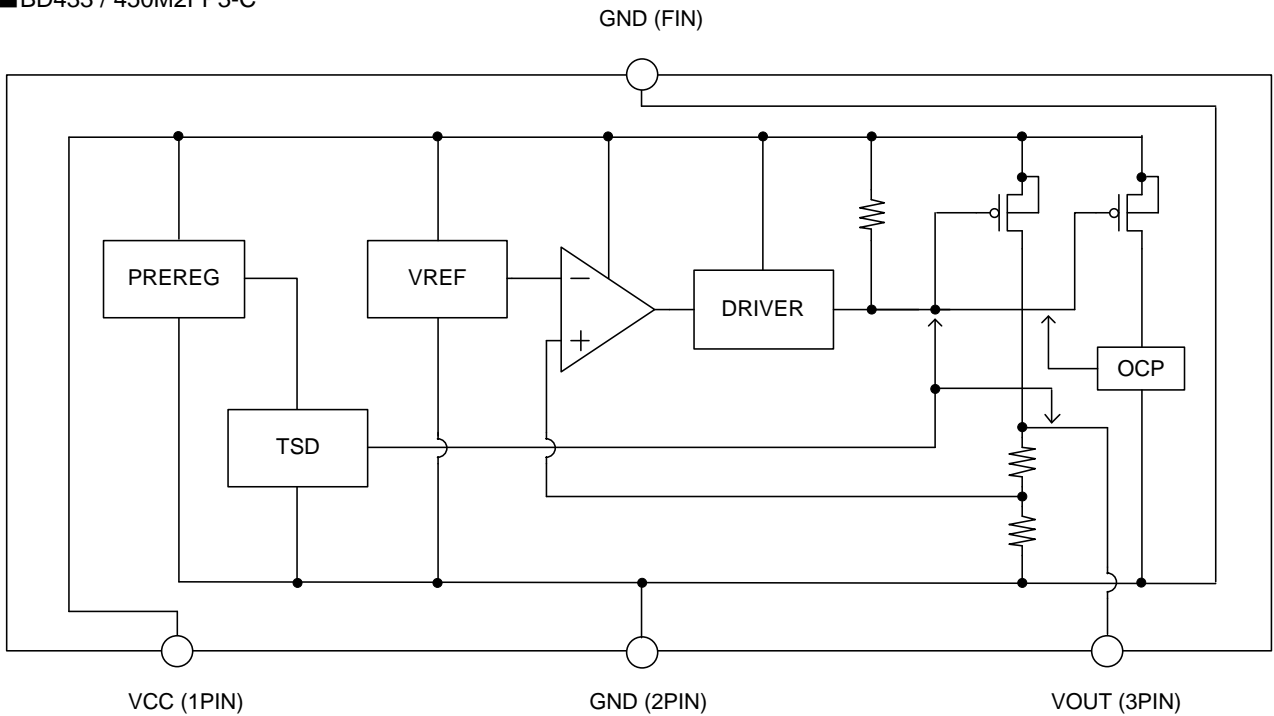

Figure 4. Block Diagrams

●Description of Blocks

Block Name	Function	Description of Blocks
CTL *1	Control Output Voltage ON/OFF	A logical "HIGH" ($\geq 2.8 \text{ V}$) at the CTL pin enables the device and "LOW" ($\leq 0.8 \text{ V}$) at the CTL pin not enable the device.
PREREG	Internal Power Supply	Power Supply for Internal Circuit
TSD	Thermal Shutdown Protection	To protect the device from overheating. If the chip temperature (T_j) reaches ca. $175 \text{ }^\circ\text{C}$ (Typ.), the output is turned off.
VREF	Reference Voltage	Generate the Reference Voltage
DRIVER	Output MOS FET Driver	Drive the Output MOS FET
OCP	Over Current Protection	To protect the device from damage caused by over current. If the output current reaches ca. 550 mA (Typ.), the output is turned off.

*1 Applicable for product with Enable Input.

● Absolute Maximum Ratings

Parameter		Symbol	Ratings	Unit
Supply Voltage	*1	VCC	-0.3 to +45.0	V
Output Control Voltage	*2	CTL	-0.3 to +45.0	V
Output Voltage		VOUT	-0.3 to +8.0	V
Power Dissipation	HTSOP-J8 *3	Pd	0.75	W
	SOT223-4F *3	Pd	0.60	W
Junction Temperature Range		Tj	-40 to +150	°C
Storage Temperature Range		Tstg	-55 to +150	°C
Maximum Junction Temperature		Tjmax	+150	°C
ESD withstand Voltage (HBM)	*4	V _{ESD,HBM}	±2000	V

*1 Do not exceed Pd.

*2 Applicable for product with Enable Input.

The start up orders of power supply (VCC) and the CTL pin do not influence if the voltage is within the operation power supply voltage range.

*3 HTSOP-J8 mounted on 114.3 mm x 76.2 mm x 1.6 mm Glass-Epoxy PCB based on JEDEC. If Ta ≥ 25 °C, reduce by 6.0 mW/°C.
(1-layer PCB: Copper foil area on the reverse side of PCB:0 mm x 0 mm)
SOT223-4F mounted on 114.3 mm x 76.2 mm x 1.6 mm Glass-Epoxy PCB based on JEDEC. If Ta ≥ 25 °C, reduce by 4.8 mW/°C.
(1-layer PCB: Copper foil area on the reverse side of PCB:0 mm x 0 mm)

*4 ESD susceptibility Human Body Model "HBM"

● Operating Conditions (-40 °C ≤ Tj ≤ +150 °C)

Parameter	Symbol	Min.	Max.	Unit	
Supply Voltage (IOUT ≤ 200 mA)	*1	VCC	4.3	42.0	V
Supply Voltage (IOUT ≤ 100 mA)	*1	VCC	3.9	42.0	V
Supply Voltage (IOUT ≤ 200 mA)	*2	VCC	5.8	42.0	V
Supply Voltage (IOUT ≤ 100 mA)	*2	VCC	5.5	42.0	V
Output Control Voltage	*3	CTL	0	42.0	V
Start-Up Voltage	*4	VCC	3.0	—	V
Output Current		IOUT	0	200	mA
Junction Temperature Range		Tj	-40	+150	°C

*1 BD433M2WEFJ-C / BD433M2WFP3-C / BD433M2EFJ-C / BD433M2FP3-C

*2 BD450M2WEFJ-C / BD450M2WFP3-C / BD450M2EFJ-C / BD450M2FP3-C

*3 Applicable for product with Enable Input

*4 When IOUT = 0 mA

● Thermal Resistance

Parameter	Symbol	Min.	Max.	Unit
HTSOP-J8 Package				
Junction to Ambient	^{*1} θ_{ja}	43.1	—	°C/W
Junction to Case (bottom)	^{*1} θ_{jc}	10	—	°C/W
SOT223-4F Package				
Junction to Ambient	^{*2} θ_{ja}	83.3	—	°C/W
Junction to Case (bottom)	^{*2} θ_{jc}	17	—	°C/W

*1 HTSOP-J8 mounted on 114.3 mm x 76.2 mm x 1.6 mm Glass-Epoxy PCB based on JEDEC.
(4-layer PCB: Copper foil on the reverse side of PCB:74.2 mm x 74.2 mm)

*2 SOT223-4F mounted on 114.3 mm x 76.2 mm x 1.6 mm Glass-Epoxy PCB based on JEDEC.
(4-layer PCB: Copper foil on the reverse side of PCB:74.2 mm x 74.2 mm)

●Electrical Characteristics

(Unless otherwise specified, $-40\text{ }^{\circ}\text{C} \leq T_j \leq +150\text{ }^{\circ}\text{C}$, $V_{CC} = 13.5\text{ V}$, $CTL = 5\text{ V}(*1)$, $I_{OUT} = 0\text{ mA}$.
The typical value is defined at $T_j = 25\text{ }^{\circ}\text{C}$.)

Parameter	Symbol	Limit			Unit	Conditions
		Min.	Typ.	Max.		
Shut Down Current	Ishut ^{*1}	—	2.0	5.0	μA	$CTL = 0\text{ V}$, $T_j \leq 125\text{ }^{\circ}\text{C}$
Circuit Current	Icc	—	40	90	μA	$I_{OUT} = 0\text{ mA}$, $T_j \leq 125\text{ }^{\circ}\text{C}$
		—	40	150	μA	$I_{OUT} \leq 200\text{ mA}$, $T_j \leq 150\text{ }^{\circ}\text{C}$
Output Voltage	VOUT ^{*2}	4.90	5.00	5.10	V	$6\text{ V} \leq V_{CC} \leq 42\text{ V}$, $0\text{ mA} \leq I_{OUT} \leq 50\text{ mA}$
		4.80	5.00	5.10	V	$6\text{ V} \leq V_{CC} \leq 42\text{ V}$, $I_{OUT} \leq 200\text{ mA}$
	VOUT ^{*3}	3.23	3.30	3.37	V	$6\text{ V} \leq V_{CC} \leq 42\text{ V}$, $0\text{ mA} \leq I_{OUT} \leq 50\text{ mA}$
		3.16	3.30	3.37	V	$6\text{ V} \leq V_{CC} \leq 42\text{ V}$, $I_{OUT} \leq 200\text{ mA}$
Dropout Voltage	ΔV_d ^{*2}	—	0.16	0.35	V	$V_{CC} = V_{OUT} \times 0.95$ (= 4.75V: Typ.), $I_{OUT} = 100\text{ mA}$
	ΔV_d ^{*3}	—	0.20	0.45	V	$V_{CC} = V_{OUT} \times 0.95$ (= 3.135V: Typ.), $I_{OUT} = 100\text{ mA}$
Ripple Rejection	R.R.	55	65	—	dB	$f = 120\text{ Hz}$, $e_{in} = 1\text{ V}_{rms}$, $I_{OUT} = 100\text{ mA}$
Line Regulation	Reg.I	—	10	30	mV	$8\text{ V} \leq V_{CC} \leq 16\text{ V}$
Load Regulation	Reg.L	—	10	30	mV	$10\text{ mA} \leq 100\text{ mA}$
Thermal Shut Down	TSD	—	175	—	$^{\circ}\text{C}$	T_j at TSD ON

*1 Applicable for product with Enable Input.

*2 For BD450M2WEFJ-C / BD450M2WFP3-C / BD450M2EFJ-C / BD450M2FP3-C

*3 For BD433M2WEFJ-C / BD433M2WFP3-C / BD433M2EFJ-C / BD433M2FP3-C

●Electrical Characteristics (Enable function * Applicable for product with Enable Input.)

(Unless otherwise specified, $-40\text{ }^{\circ}\text{C} \leq T_j \leq +150\text{ }^{\circ}\text{C}$, $V_{CC} = 13.5\text{ V}$, $I_{OUT} = 0\text{ mA}$. The Typical value is defined at $T_j = 25\text{ }^{\circ}\text{C}$.)

Parameter	Symbol	Limit			Unit	Conditions
		Min.	Typ.	Max.		
CTL ON Mode Voltage	VthH	2.8	—	—	V	ACTIVE MODE
CTL OFF Mode Voltage	VthL	—	—	0.8	V	OFF MODE
CTL Bias Current	ICTL	—	15	30	μA	$CTL = 5\text{ V}$

● Typical Performance Curves

■ BD433M2WEFJ-C / BD433M2EFJ-C / BD433M2WFP3-C / BD433M2FP3-C Reference Data

Unless otherwise specified: $-40\text{ }^{\circ}\text{C} \leq T_j \leq +150\text{ }^{\circ}\text{C}$, $V_{CC} = 13.5\text{ V}$, $CTL = 5\text{ V}$ (*1), $I_{OUT} = 0\text{ mA}$.

*1 Applicable for product with Enable Input.

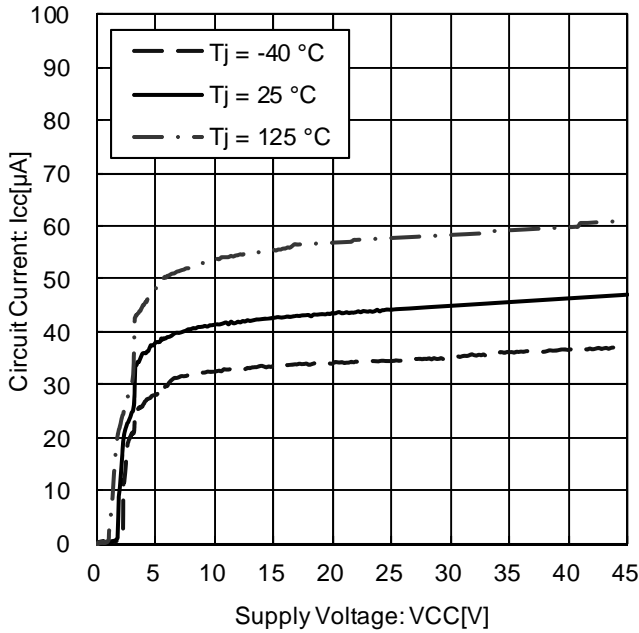

Figure 5. Circuit Current vs. Power Supply Voltage

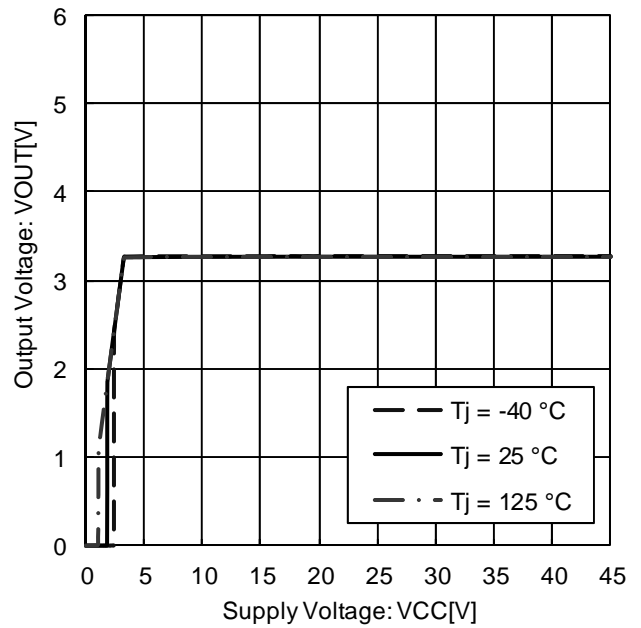

Figure 6. Output Voltage vs. Power Supply Voltage ($I_{OUT} = 0\text{ mA}$)

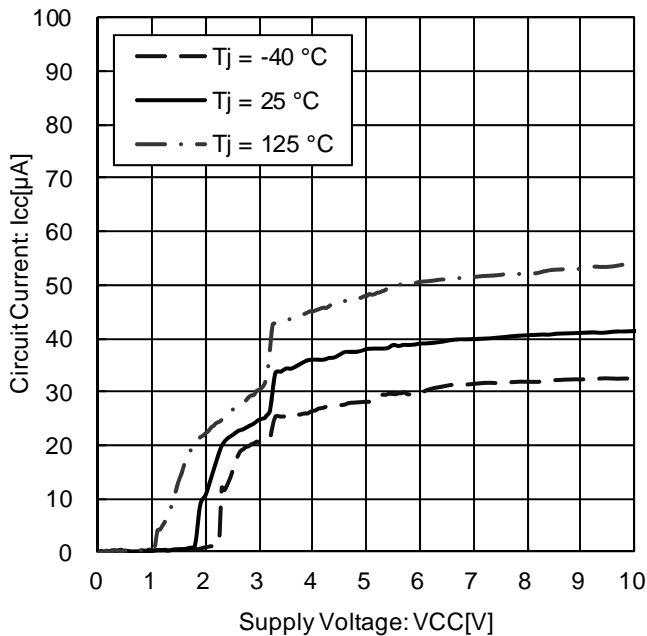

Figure 7. Circuit Current vs. Power Supply Voltage
*magnified Figure 5. at low supply voltage

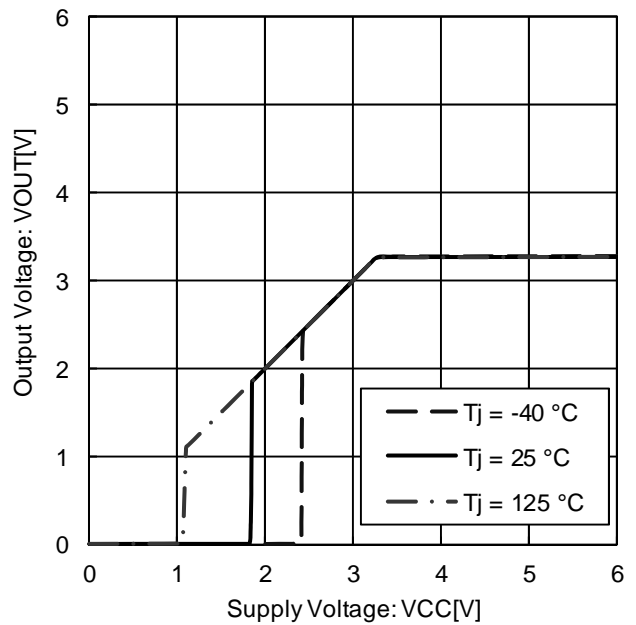

Figure 8. Output Voltage vs. Power Supply Voltage ($I_{OUT} = 0\text{ mA}$)
*magnified Figure 6. at low supply voltage

● Typical Performance Curves

■ BD433M2WEFJ-C / BD433M2EFJ-C / BD433M2WFP3-C / BD433M2FP3-C Reference Data

Unless otherwise specified: $-40\text{ }^{\circ}\text{C} \leq T_j \leq +150\text{ }^{\circ}\text{C}$, $V_{CC} = 13.5\text{ V}$, $CTL = 5\text{ V}$ (*1), $I_{OUT} = 0\text{ mA}$.

*1 Applicable for product with Enable Input.

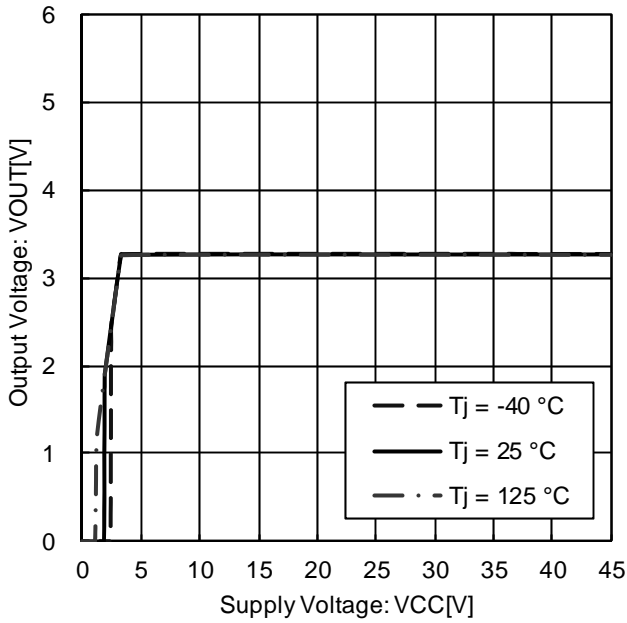

Figure 9. Output Voltage vs. Power Supply Voltage ($I_{OUT} = 10\text{ mA}$)

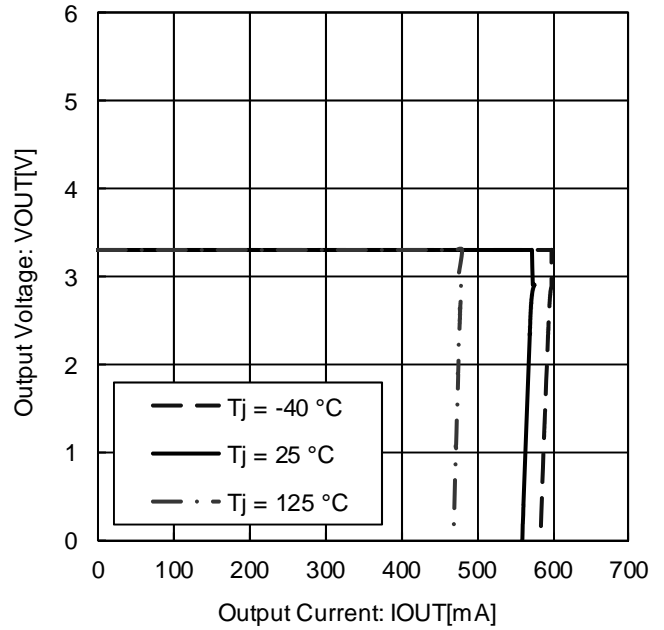

Figure 10. Output Voltage vs. Output Current (Over Current Protection)

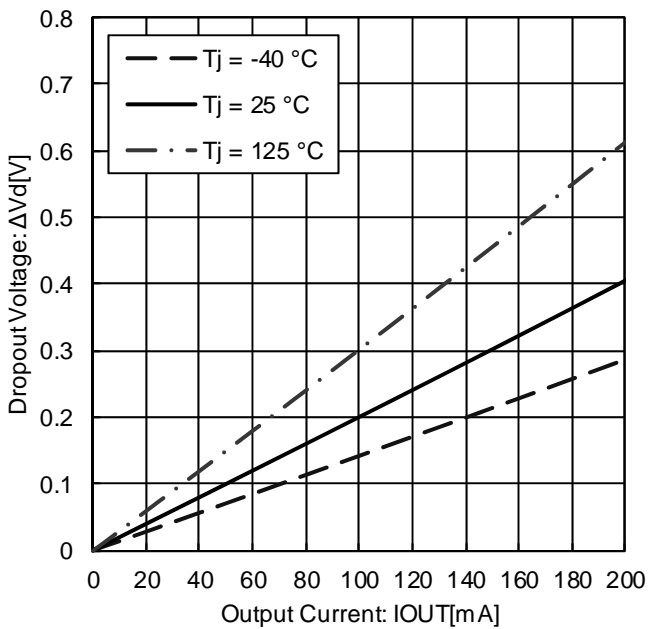

Figure 11. Dropout Voltage ($V_{CC} = 3.135\text{ V}$)

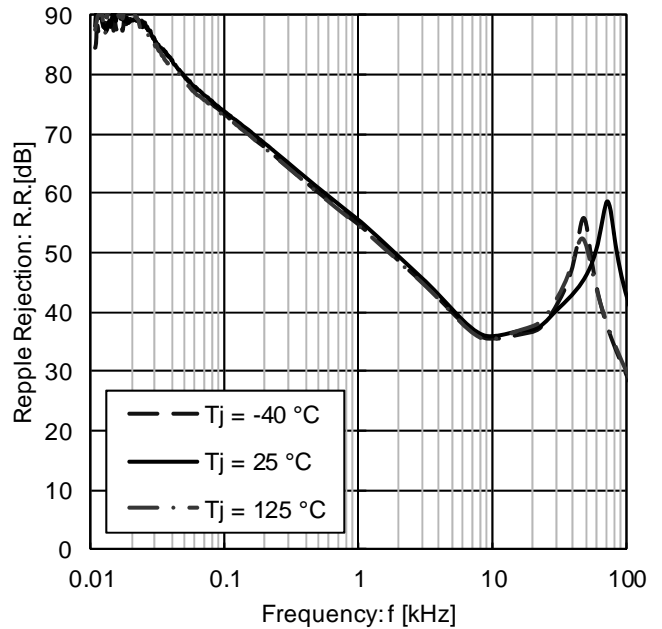

Figure 12. Ripple Rejection ($e_{in} = 1\text{ V}_{rms}$, $I_{OUT} = 100\text{ mA}$)

● Typical Performance Curves

■ BD433M2WEFJ-C / BD433M2EFJ-C / BD433M2WFP3-C / BD433M2FP3-C Reference Data

Unless otherwise specified: $-40\text{ }^{\circ}\text{C} \leq T_j \leq +150\text{ }^{\circ}\text{C}$, $V_{CC} = 13.5\text{ V}$, $CTL = 5\text{ V}$ (*1), $I_{OUT} = 0\text{ mA}$.

*1 Applicable for product with Enable Input.

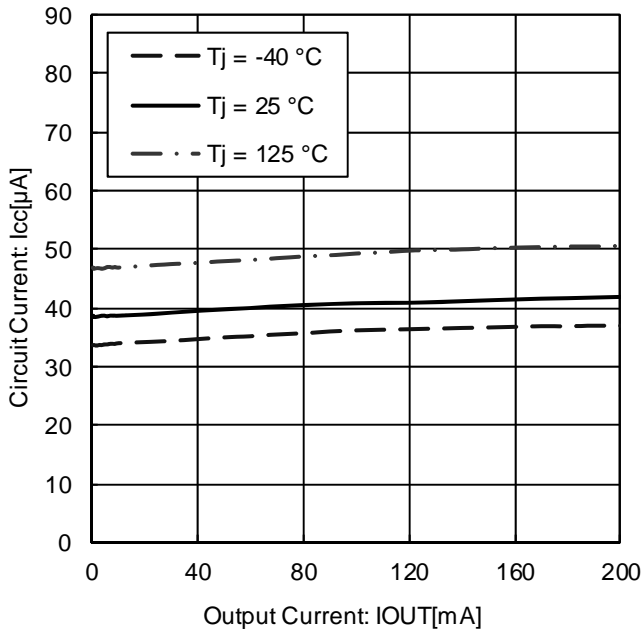

Figure 13. Circuit Current vs. Output Current

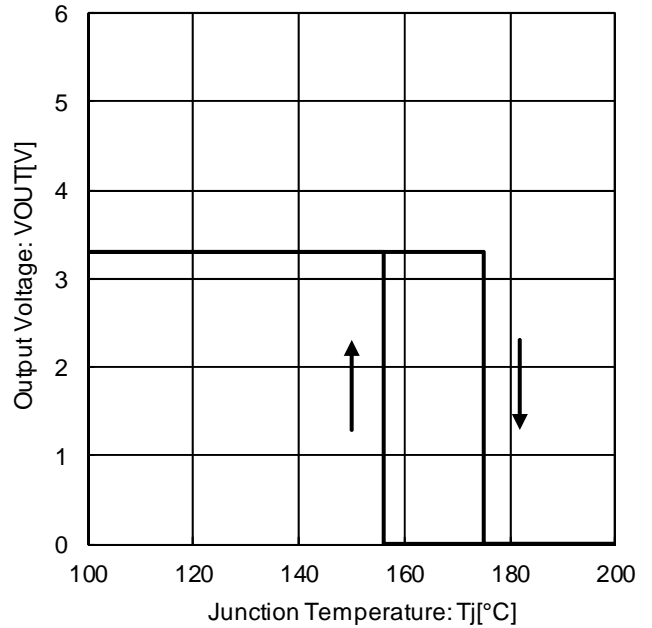

Figure 14. Output Voltage vs. Temperature (Thermal Shut Down)

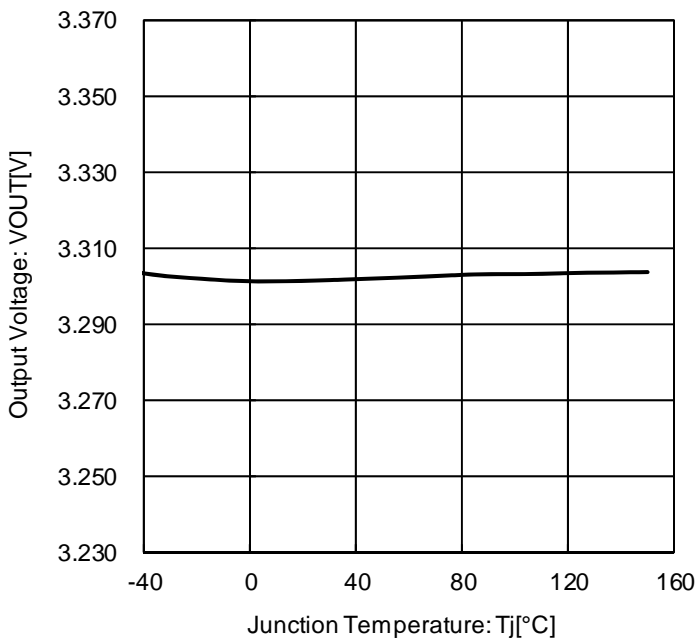

Figure 15. Output Voltage vs. Temperature

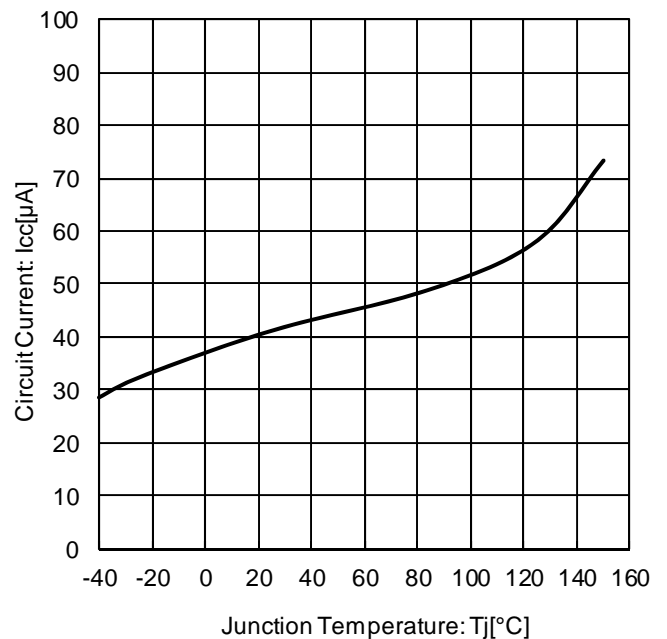

Figure 16. Circuit Current vs. Temperature

● Typical Performance Curves

■ BD433M2WEFJ-C / BD433M2WFP3-C Reference Data

Unless otherwise specified: $-40\text{ °C} \leq T_j \leq +150\text{ °C}$, $V_{CC} = 13.5\text{ V}$, $I_{OUT} = 0\text{ mA}$

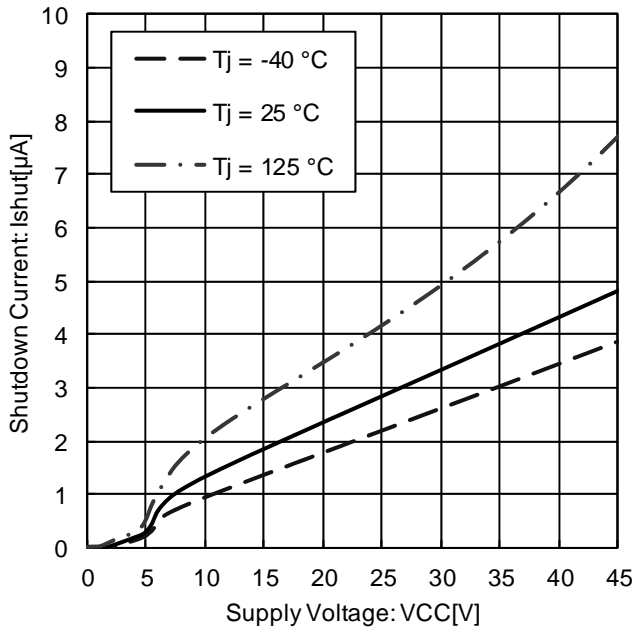

Figure 17. Shut Down Current vs. Power Supply Voltage (CTL = 0 V)

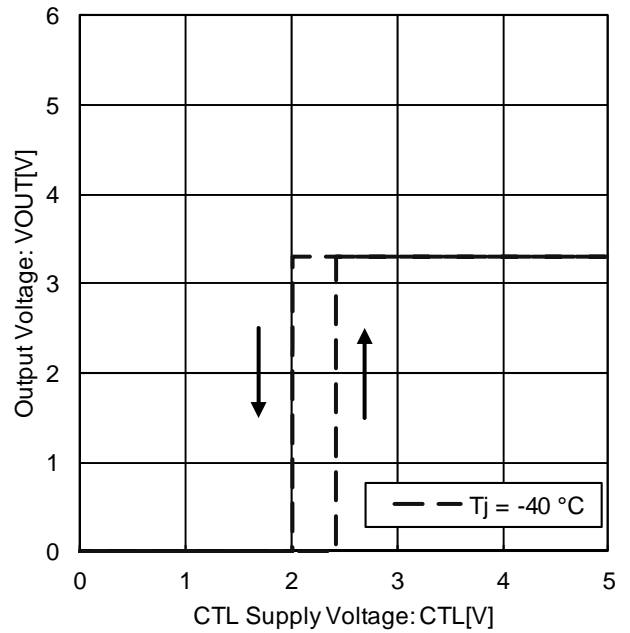

Figure 18. CTL ON / OFF Mode Voltage ($T_j = -40\text{ °C}$)

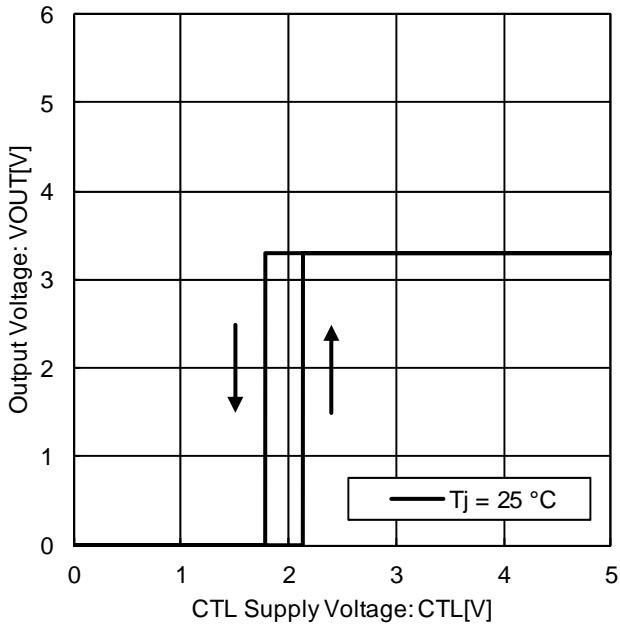

Figure 19. CTL ON / OFF Mode Voltage ($T_j = 25\text{ °C}$)

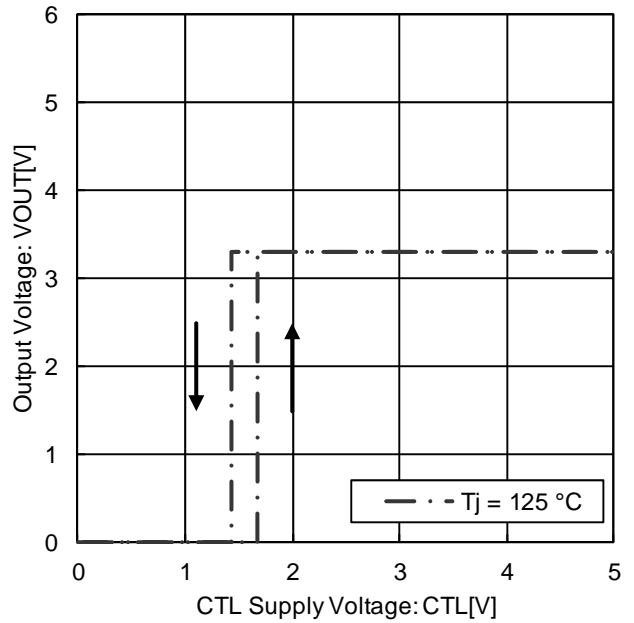

Figure 20. CTL ON / OFF Mode Voltage ($T_j = 125\text{ °C}$)

● Typical Performance Curves

■ BD433M2WEFJ-C / BD433M2WFP3-C Reference Data

Unless otherwise specified: $-40\text{ °C} \leq T_j \leq +150\text{ °C}$, $V_{CC} = 13.5\text{ V}$, $I_{OUT} = 0\text{ mA}$

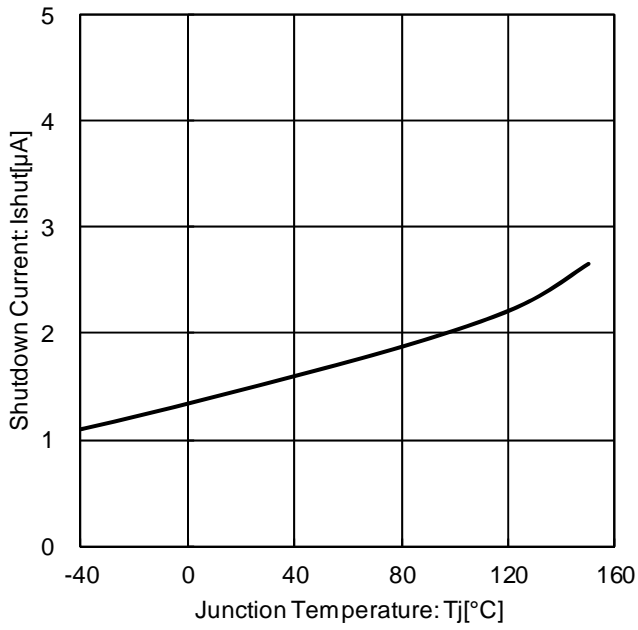

Figure 21. Shut Down Current vs. Temperature (CTL = 0 V)

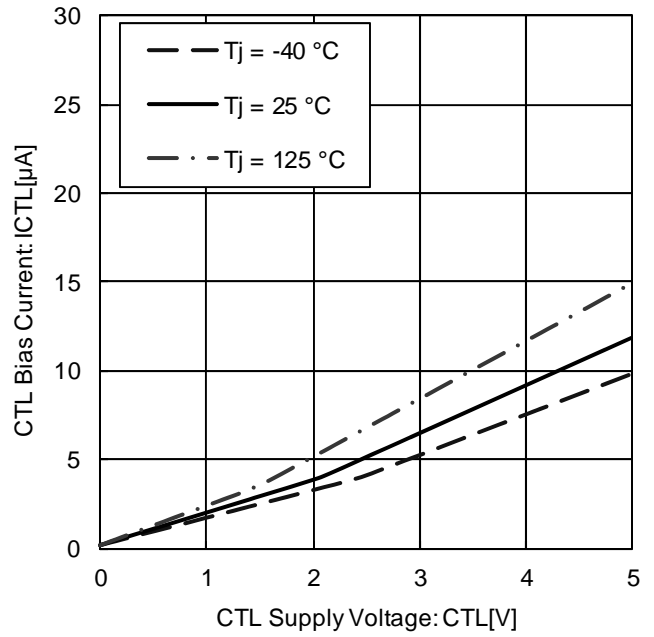

Figure 22. CTL Bias Current vs. CTL Supply Voltage

● Typical Performance Curves

■ BD450M2WEFJ-C / BD450M2EFJ-C / BD450M2WFP3-C / BD450M2FP3-C Reference Data

Unless otherwise specified: $-40\text{ °C} \leq T_j \leq +150\text{ °C}$, $V_{CC} = 13.5\text{ V}$, $CTL = 5\text{ V} (*1)$, $I_{OUT} = 0\text{ mA}$

*1 Applicable for product with Enable Input.

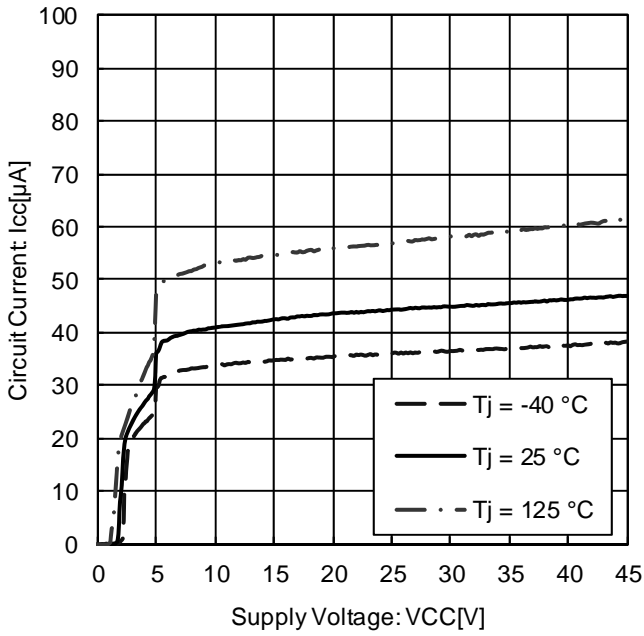

Figure 23. Circuit Current vs. Power Supply Voltage

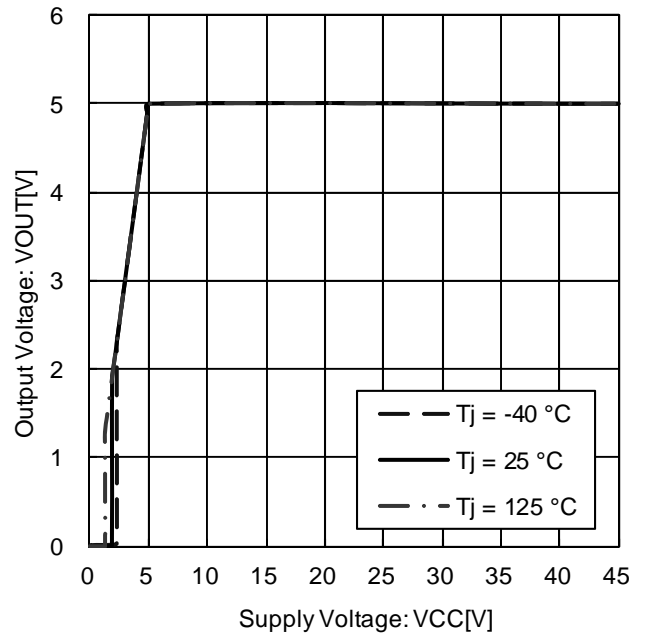

Figure 24. Output Voltage vs. Power Supply Voltage (IOUT = 0 mA)

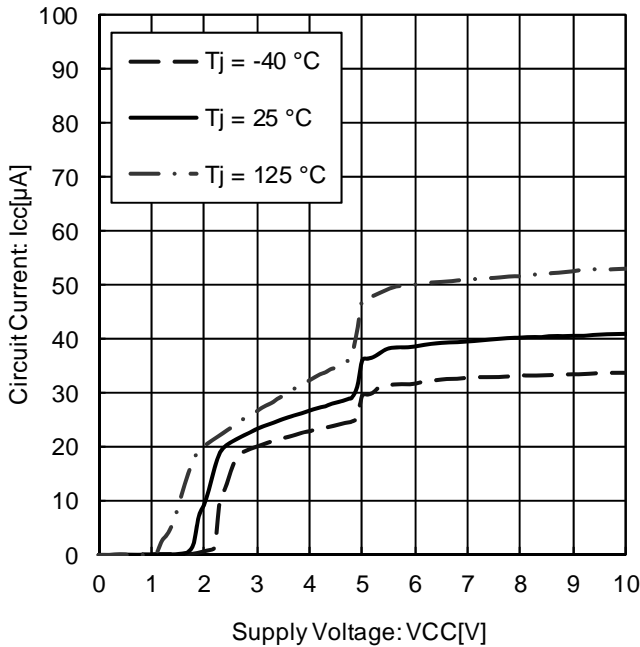

Figure 25. Circuit Current vs. Power Supply Voltage
*magnified Figure 23. at low supply voltage

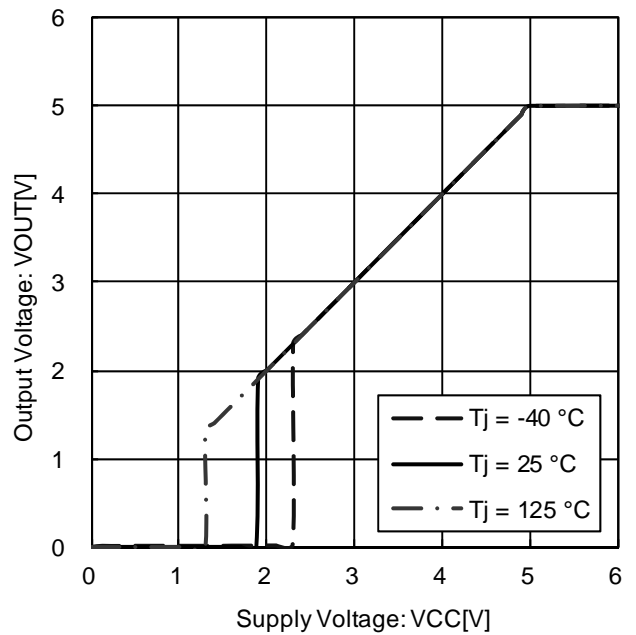

Figure 26. Output Voltage vs. Power Supply Voltage (IOUT = 0 mA)
*magnified Figure 24. at low supply voltage

● Typical Performance Curves

■ BD450M2WEFJ-C / BD450M2EFJ-C / BD450M2WFP3-C / BD450M2FP3-C Reference Data

Unless otherwise specified: $-40\text{ }^{\circ}\text{C} \leq T_j \leq +150\text{ }^{\circ}\text{C}$, $V_{CC} = 13.5\text{ V}$, $CTL = 5\text{ V}$ (*1), $I_{OUT} = 0\text{ mA}$

*1 Applicable for product with Enable Input.

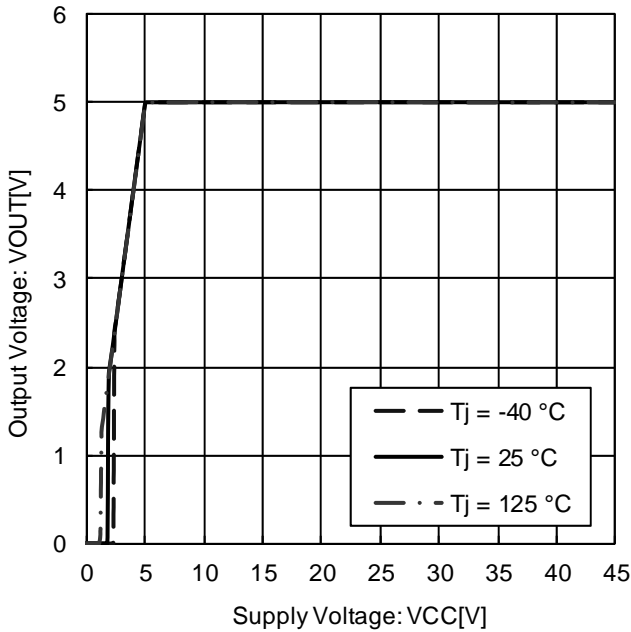

Figure 27. Output Voltage vs. Power Supply Voltage ($I_{OUT} = 10\text{ mA}$)

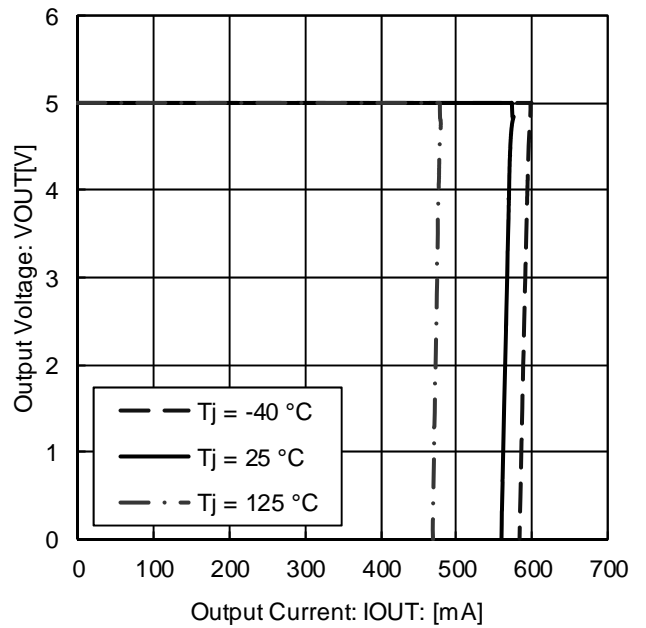

Figure 28. Output Voltage vs. Output Current (Over Current Protection)

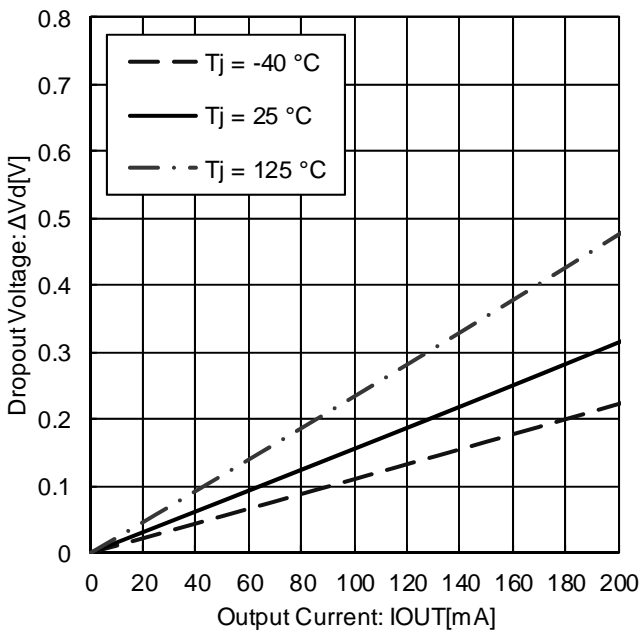

Figure 29. Dropout Voltage ($V_{CC} = 4.75\text{ V}$)

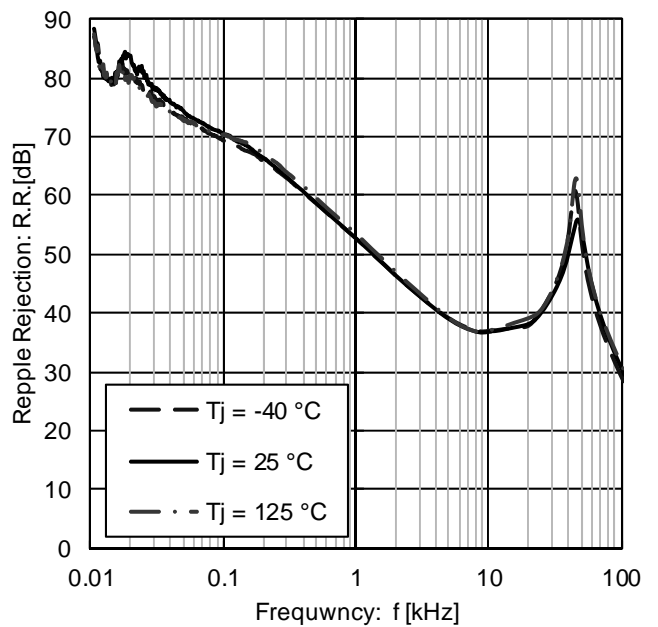

Figure 30. Ripple Rejection ($e_{in} = 1\text{ V}_{rms}$, $I_{OUT} = 100\text{ mA}$)

● Typical Performance Curves

■ BD450M2WEFJ-C / BD450M2EFJ-C / BD450M2WFP3-C / BD450M2FP3-C Reference Data

Unless otherwise specified: $-40\text{ °C} \leq T_j \leq +150\text{ °C}$, $V_{CC} = 13.5\text{ V}$, $CTL = 5\text{ V} (*1)$, $I_{OUT} = 0\text{ mA}$

*1 Applicable for product with Enable Input.

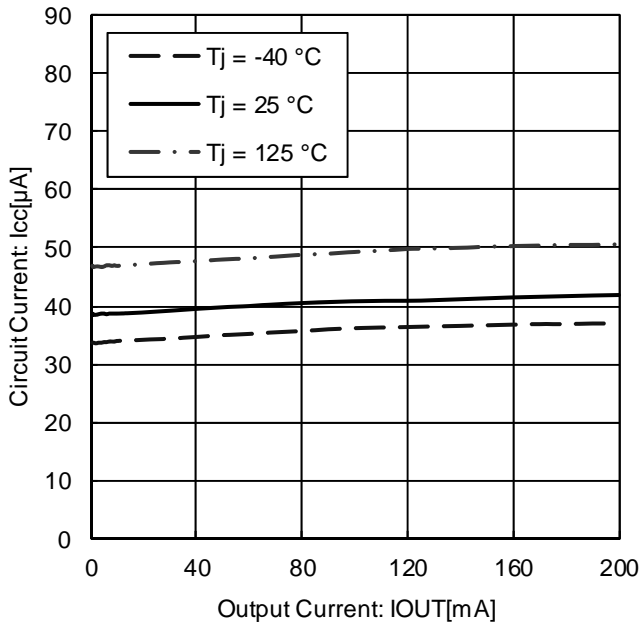

Figure 31. Circuit Current vs. Output Current

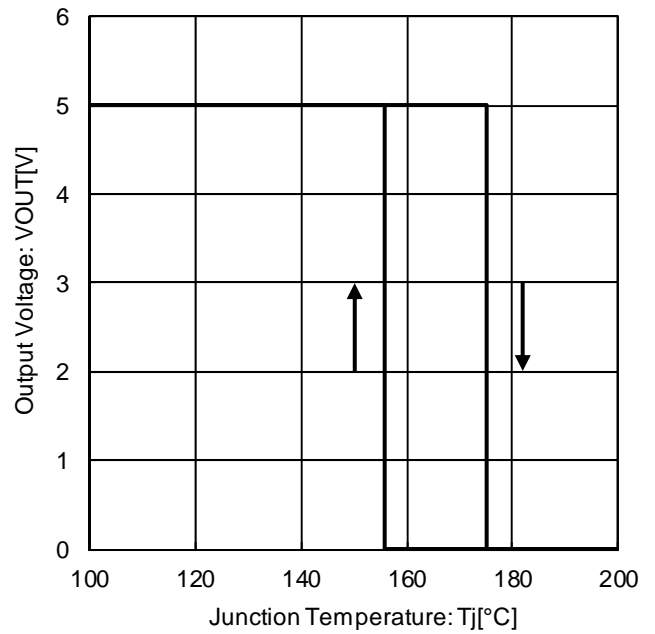

Figure 32. Output Voltage vs. Temperature (Thermal Shut Down)

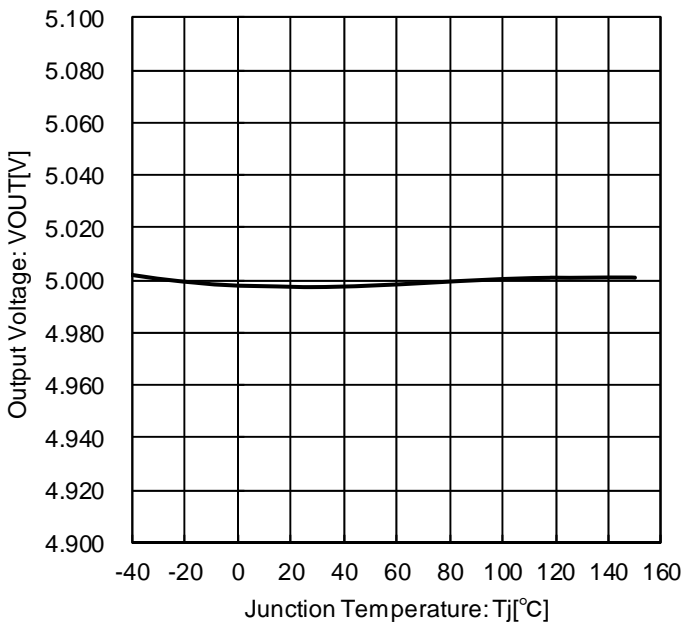

Figure 33. Output Voltage vs. Temperature

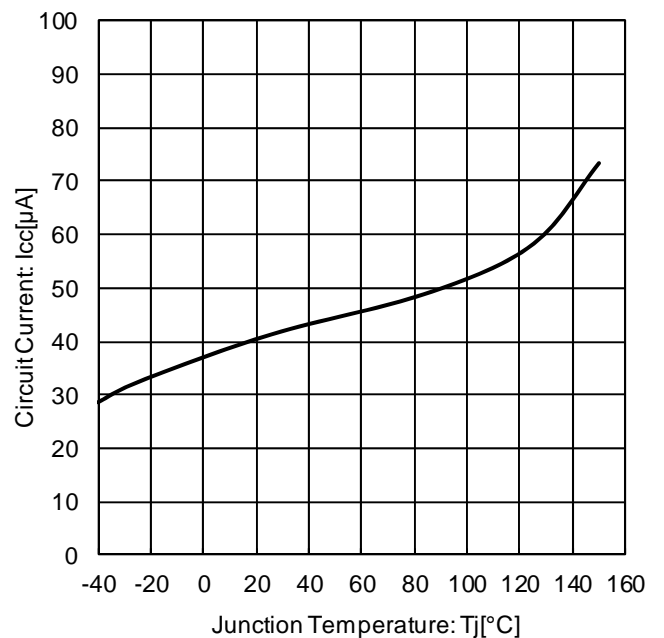

Figure 34. Circuit Current vs. Temperature

● Typical Performance Curves

■ BD450M2WEFJ-C / BD450M2WFP3-C Reference Data

Unless otherwise specified: $-40\text{ °C} \leq T_j \leq +150\text{ °C}$, $V_{CC} = 13.5\text{ V}$, $I_{OUT} = 0\text{ mA}$

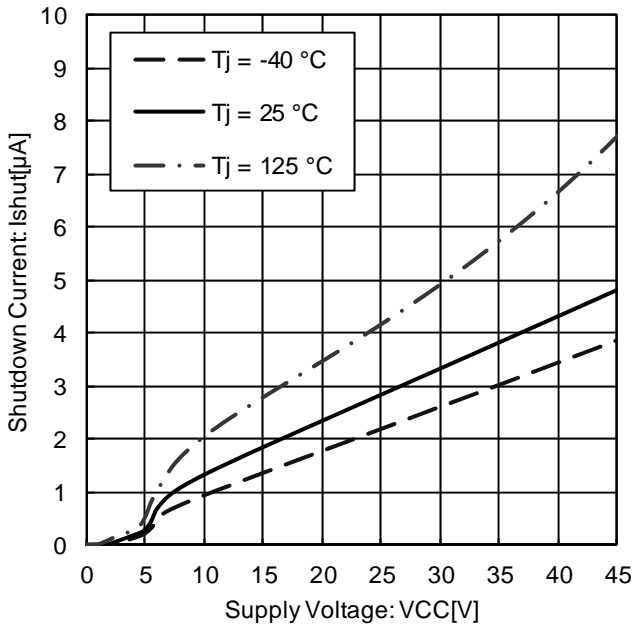

Figure 35. Shut Down Current vs. Power Supply Voltage (CTL = 0 V)

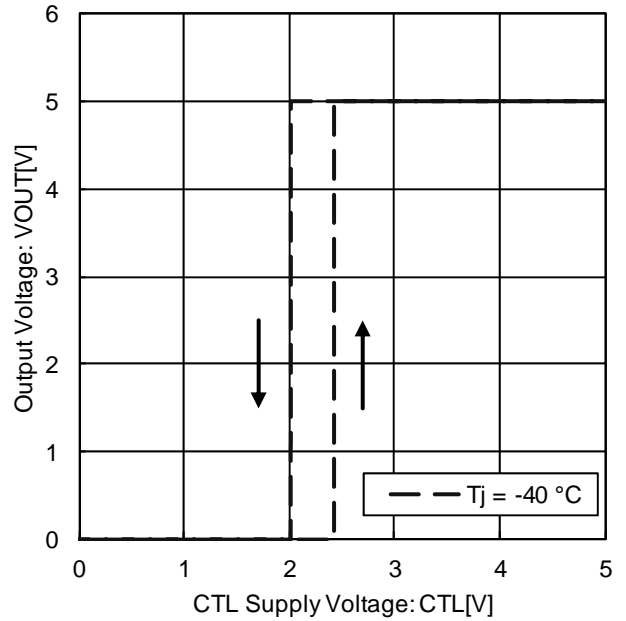

Figure 36. CTL ON / OFF Mode Voltage ($T_j = -40\text{ °C}$)

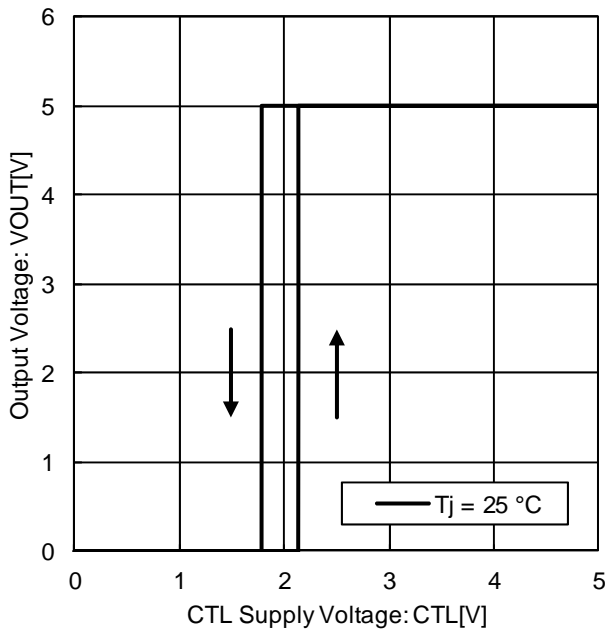

Figure 37. CTL ON / OFF Mode Voltage ($T_j = 25\text{ °C}$)

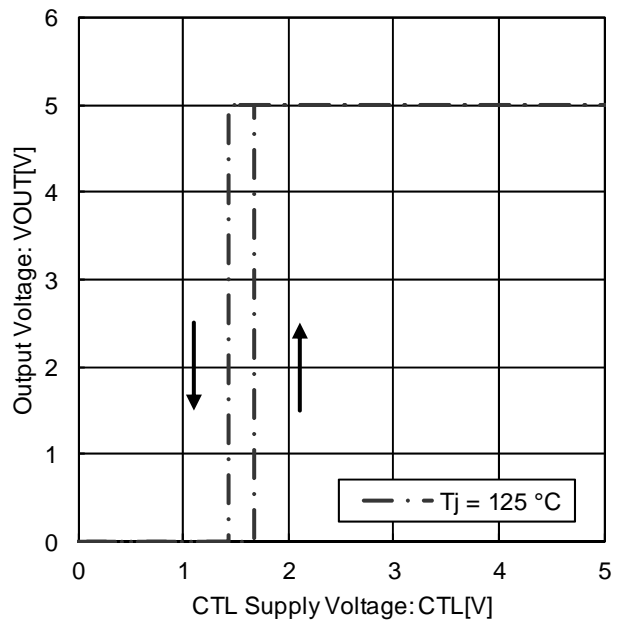

Figure 38. CTL ON / OFF Mode Voltage ($T_j = 125\text{ °C}$)

● Typical Performance Curves

■ BD450M2WEFJ-C / BD450M2WFP3-C Reference Data

Unless otherwise specified: $-40\text{ }^{\circ}\text{C} \leq T_j \leq +150\text{ }^{\circ}\text{C}$, $V_{CC} = 13.5\text{ V}$, $I_{OUT} = 0\text{ mA}$

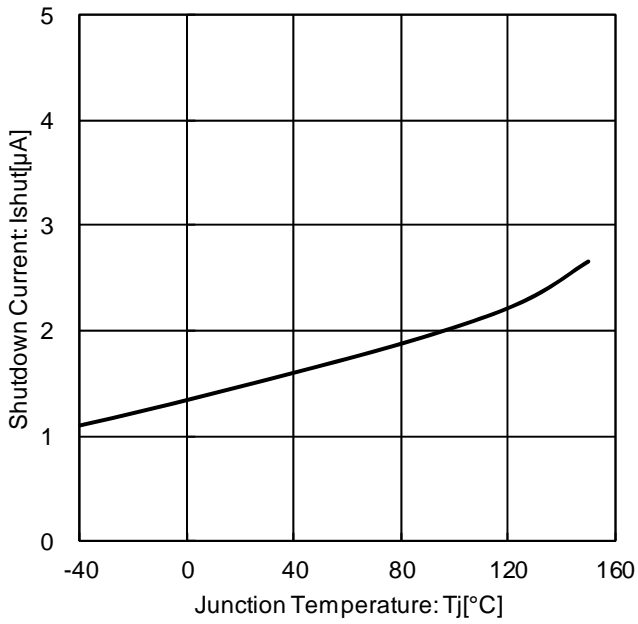

Figure 39. Shut Down Current vs. Temperature (CTL = 0 V)

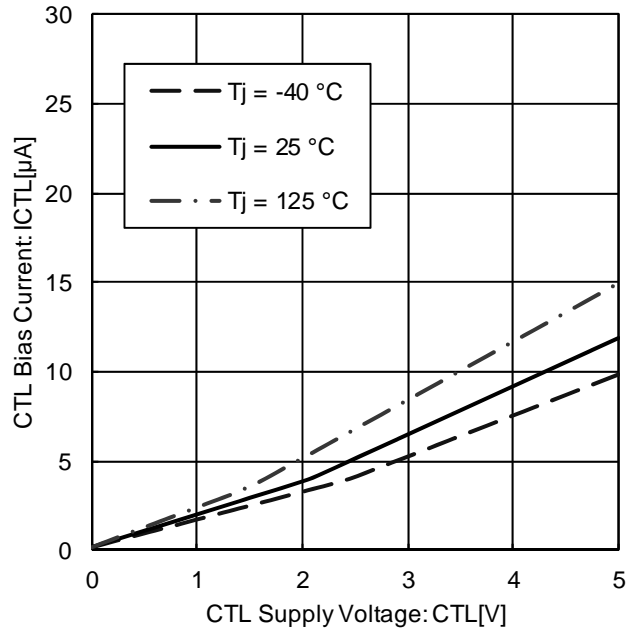
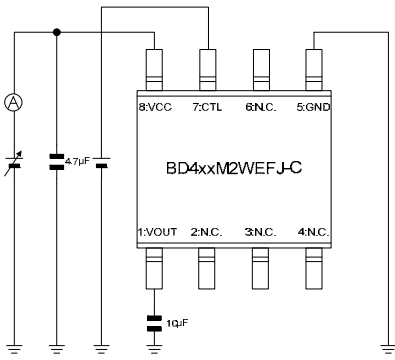
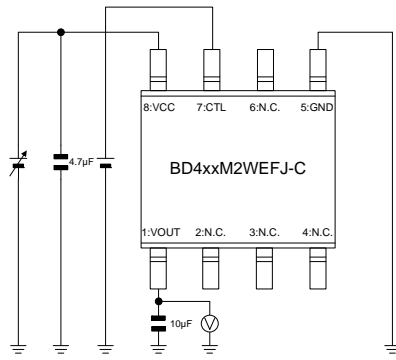

Figure 40. CTL Bias Current vs. CTL Supply Voltage

● Measurement Circuit for Typical Performance Curves (BD433 / 450M2WEFJ-C)



Measurement Setup for
Figure 5, 7, 16, 17, 21,
Figure 23, 25, 34, 35, 39



Measurement Setup for
Figure 6, 8, 14, 15,
Figure 24, 26, 32, 33

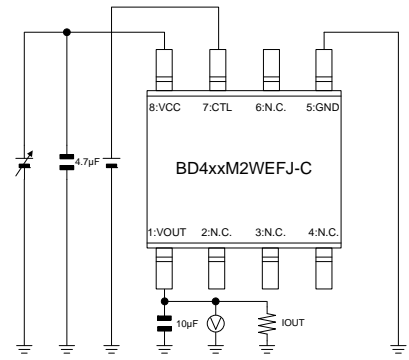

Measurement Setup for
Figure 9, 27

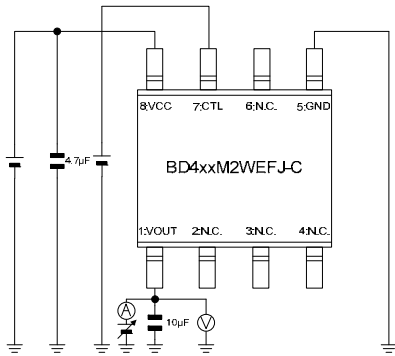

Measurement Setup for
Figure 10, 28

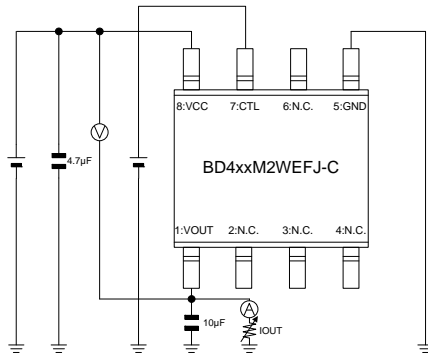

Measurement Setup for
Figure 11, 29

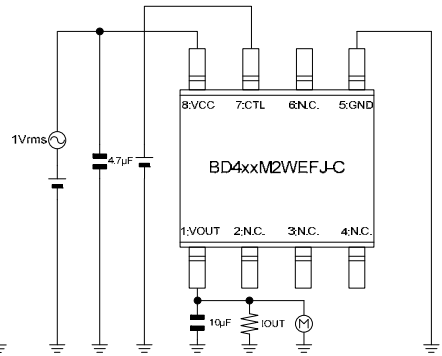

Measurement Setup for
Figure 12, 30

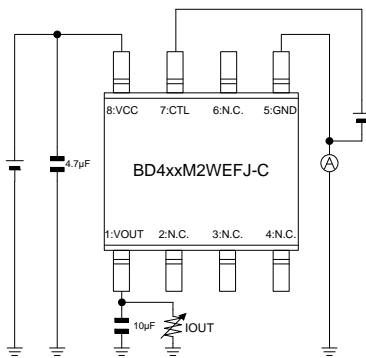

Measurement Setup for
Figure 13, 31

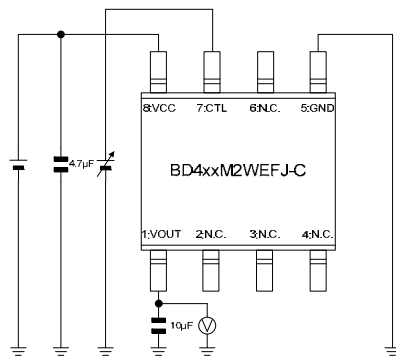

Measurement Setup for
Figure 18, 19, 20,
Figure 36, 37, 38

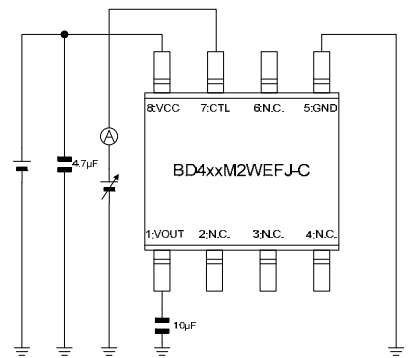

Measurement Setup for
Figure 22, 40

● Measurement Circuit for Typical Performance Curves (BD433 / 450M2EFJ-C)

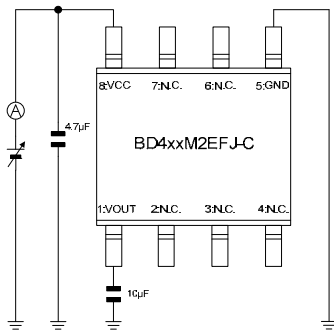

Measurement Setup for Figure 5, 7, 16, Figure 23, 25, 34

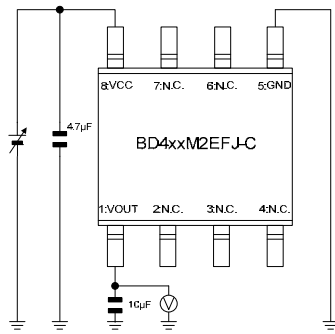

Measurement Setup for Figure 6, 8, 14, 15, Figure 24, 26, 32, 33

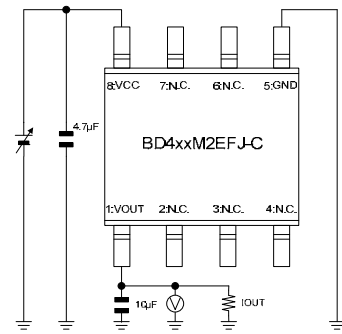

Measurement Setup for Figure 9, 27

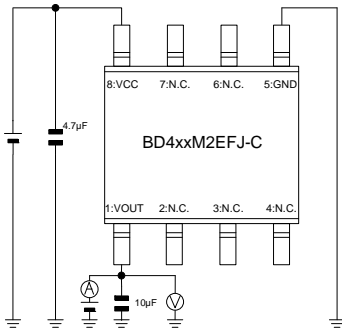

Measurement Setup for Figure 10, 28

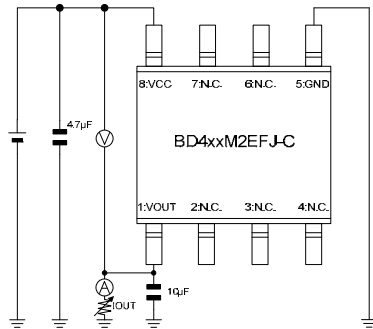

Measurement Setup for Figure 11, 29

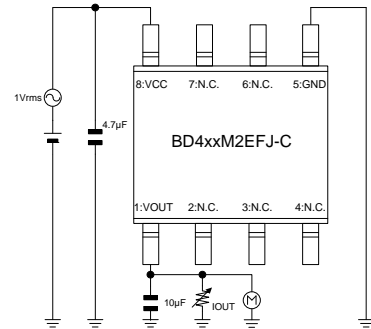

Measurement Setup for Figure 12, 30

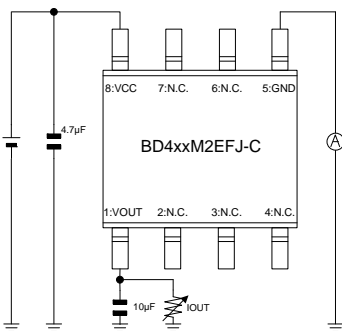

Measurement Setup for Figure 13, 31

● Measurement Circuit for Typical Performance Curves (BD433 / 450M2WFP3-C)

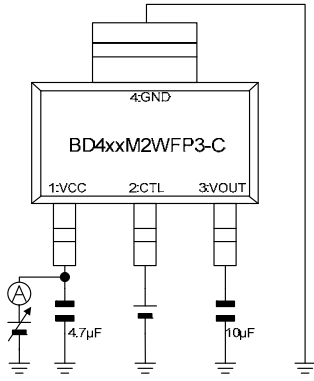

Measurement Setup for Figure 5, 7, 16, 17, 21, Figure 23, 25, 34, 35, 39

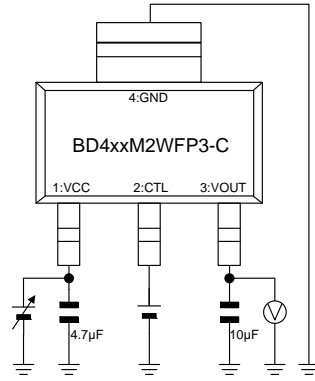

Measurement Setup for Figure 6, 8, 14, 15, Figure 24, 26, 32, 33

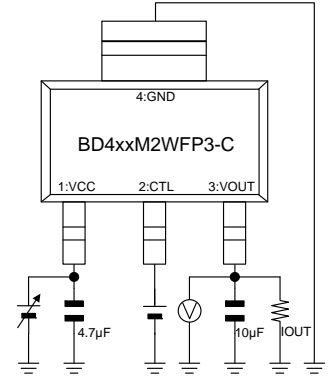

Measurement Setup for Figure 9, 27

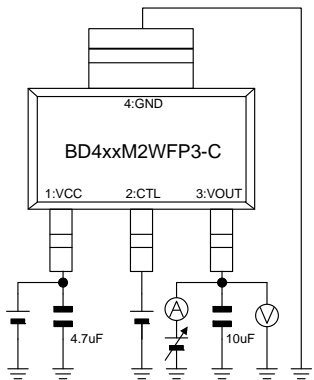

Measurement Setup for Figure 10, 28

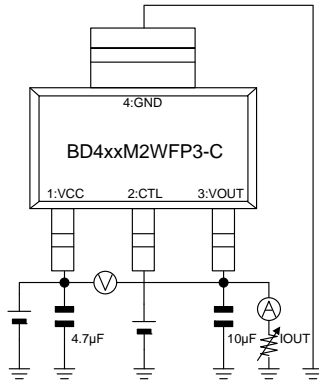

Measurement Setup for Figure 11, 29

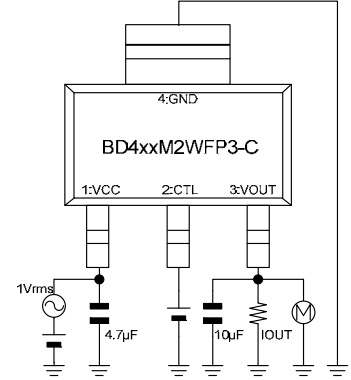

Measurement Setup for Figure 12, 30

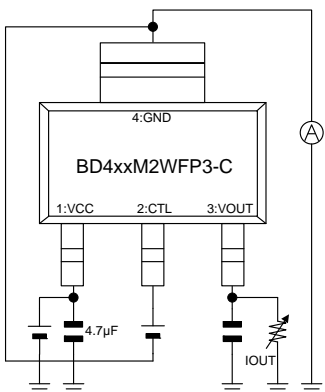

Measurement Setup for Figure 13, 31

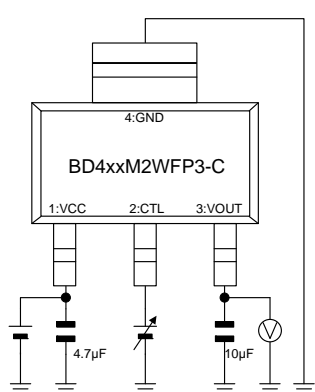

Measurement Setup for Figure 18, 19, 20, Figure 36, 37, 38

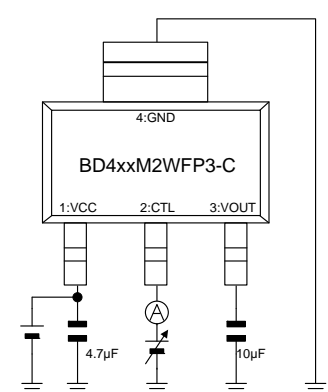

Measurement Setup for Figure 22, 40

● Measurement Circuit for Typical Performance Curves (BD433 / 450M2FP3-C)

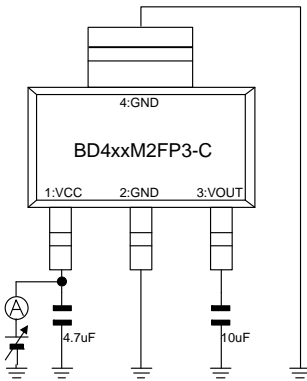

Measurement Setup for
Figure 5, 7, 16,
Figure 23, 25, 34

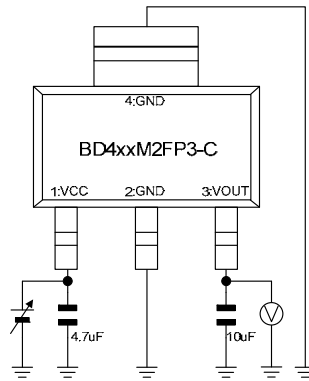

Measurement Setup for
Figure 6, 8, 14, 15,
Figure 24, 26, 32, 33

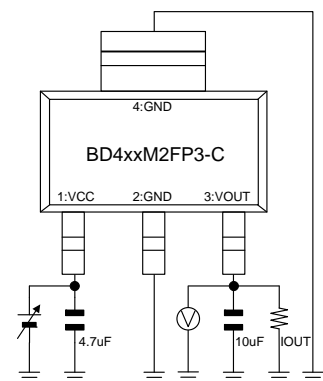

Measurement Setup for
Figure 9, 27

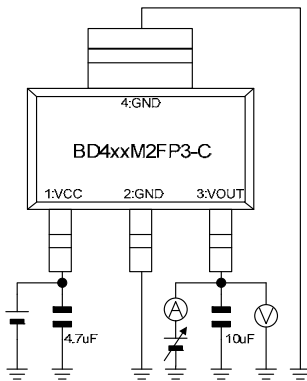

Measurement Setup for
Figure 10, 28

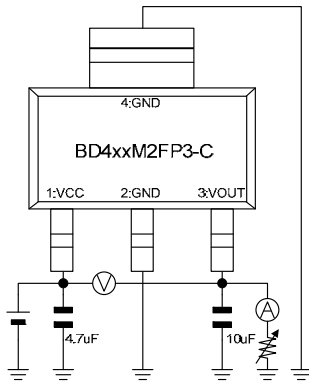

Measurement Setup for
Figure 11, 29

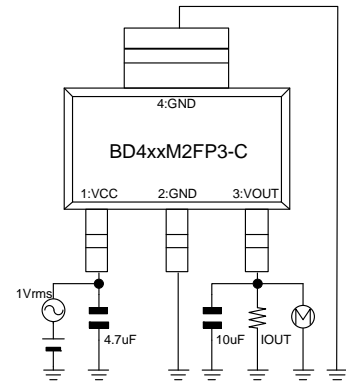

Measurement Setup for
Figure 12, 30

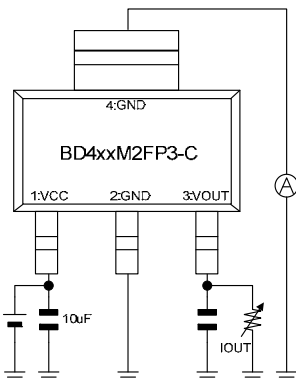

Measurement Setup for
Figure 13, 31

● Selection of Components Externally Connected

• VCC Pin

Insert Capacitors with a capacitance of 0.1 μF or higher between the VCC and GND pin. Choose the capacitance according to the line between the power smoothing circuit and the VCC pin. Selection of the capacitance also depends on the application. Verify the application and allow sufficient margins in the design. We recommend using a capacitor with excellent voltage and temperature characteristics.

• Output Pin Capacitor

In order to prevent oscillation, a capacitor needs to be placed between the output pin and GND pin. We recommend using a capacitor with a capacitance of 10 μF (Typ.) or higher. Electrolytic, tantalum and ceramic capacitors can be used. When selecting the capacitor ensure that the capacitance of 6 μF or higher is maintained at the intended applied voltage and temperature range. Due to changes in temperature the capacitor's capacitance can fluctuate possibly resulting in oscillation. For selection of the capacitor refer to the data of Figure 41.

The stable operation range given in the data of Figure 41 is based on the standalone IC and resistive load. For actual applications the stable operating range is influenced by the PCB impedance, input supply impedance and load impedance. Therefore verification of the final operating environment is needed.

When selecting a ceramic type capacitor, we recommend using X5R, X7R or better with excellent temperature and DC-biasing characteristics and high voltage tolerance.

Also, in case of rapidly changing input voltage and load current, select the capacitance in accordance with verifying that the actual application meets with the required specification.

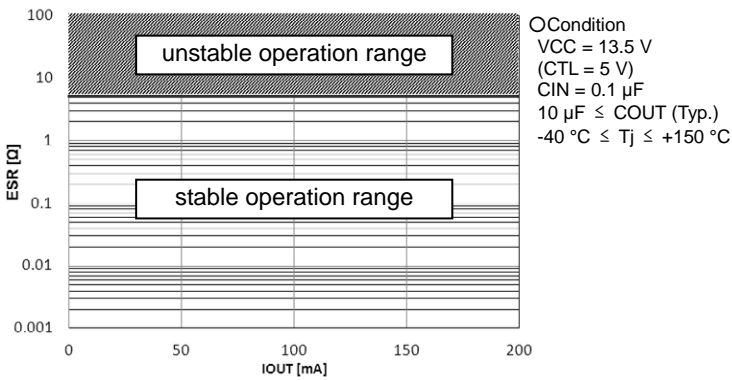

Figure 41. ESR vs. IOU

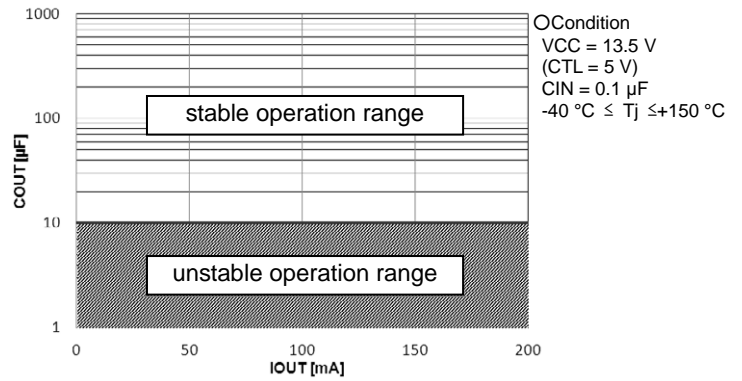

Figure 42. COU vs. IOU

● Measurement Setup

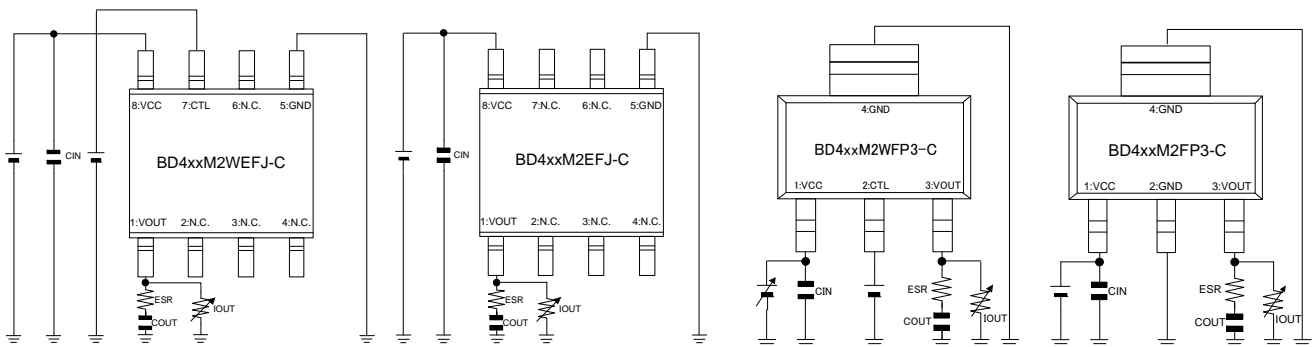
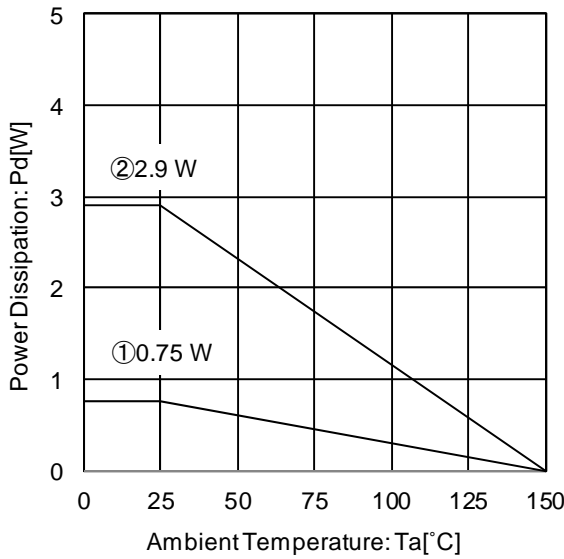

Figure 43. Measurement Setups for ESR Reference Data (about Output Pin Capacitor)

● Power Dissipation

■ HTSOP-J8



IC mounted on ROHM standard board based on JEDEC.
 Board material: FR4
 Board size: 114.3 mm x 76.2 mm x 1.6 mm
 (with thermal via on the board)
 Mount condition: PCB and exposed pad are soldered.
 Top copper foil: The footprint ROHM recommend.
 + wiring to measure.

- ① : 1-layer PCB
 (Copper foil area on the reverse side of PCB: 0 mm x 0 mm)
- ② : 4-layer PCB
 (2 inner layers and Copper foil area on the reverse side of PCB:
 74.2mm x 74.2 mm)

Condition①: $\theta_{ja} = 166.7 \text{ }^\circ\text{C/W}$, $\theta_{jc} \text{ (top)} = 45 \text{ }^\circ\text{C/W}$
 Condition②: $\theta_{ja} = 43.1 \text{ }^\circ\text{C/W}$, $\theta_{jc} \text{ (top)} = 16 \text{ }^\circ\text{C/W}$, $\theta_{jc} \text{ (bottom)} = 10 \text{ }^\circ\text{C/W}$

Figure 44. Package Data (HTSOP-J8)

■ SOT223-4F

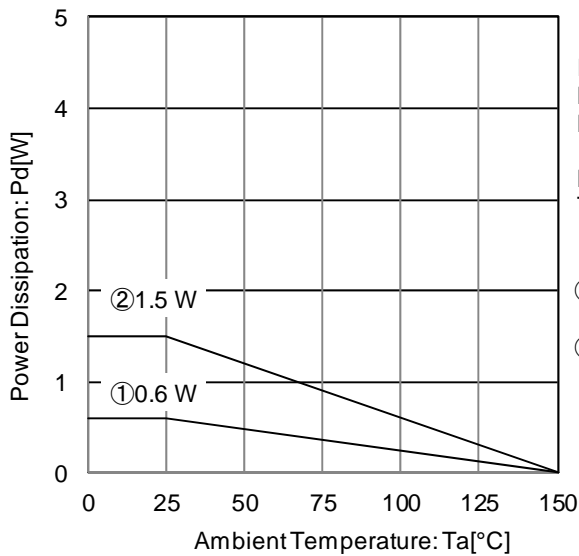

IC mounted on ROHM standard board based on JEDEC.
 Board material: FR4
 Board size: 114.3 mm x 76.2 mm x 1.6 mm
 (with thermal via on the board)
 Mount condition: PCB and exposed pad are soldered.
 Top copper foil: The footprint ROHM recommend.
 + wiring to measure.

- ① : 1-layer PCB
 (Copper foil area on the reverse side of PCB: 0 mm x 0 mm)
- ② : 4-layer PCB
 (2 inner layers and Copper foil area on the reverse side of PCB:
 74.2mm x 74.2 mm)

Condition①: $\theta_{ja} = 208.3 \text{ }^\circ\text{C/W}$, $\theta_{jc} \text{ (top)} = 52 \text{ }^\circ\text{C/W}$
 Condition②: $\theta_{ja} = 83.3 \text{ }^\circ\text{C/W}$, $\theta_{jc} \text{ (top)} = 36 \text{ }^\circ\text{C/W}$, $\theta_{jc} \text{ (bottom)} = 17 \text{ }^\circ\text{C/W}$

Figure 45. Package Data (SOT223-4F)

Refer to the heat mitigation characteristics illustrated in Figure 44, 45 when using the IC in an environment of $T_a \geq 25^\circ\text{C}$. The characteristics of the IC are greatly influenced by the operating temperature, and it is necessary to operate under the maximum junction temperature $T_{j\text{max}}$.

Even if the ambient temperature T_a is at 25°C it is possible that the junction temperature T_j reaches high temperatures. Therefore, the IC should be operated within the power dissipation range.

The following method is used to calculate the power consumption P_c (W)

$$P_c = (V_{CC} - V_{OUT}) \times I_{OUT} + V_{CC} \times I_{CC}$$

$$\text{Power dissipation } P_d \geq P_c$$

V_{CC} : Input Voltage
 V_{OUT} : Output Voltage
 I_{OUT} : Load Current
 I_{CC} : Circuit Current
 P_c : Power Consumption

The load current I_{OUT} is obtained by operating the IC within the power dissipation range.

$$I_{OUT} \leq \frac{P_d - V_{CC} \times I_{CC}}{V_{CC} - V_{OUT}} \quad (\text{Refer to Figure 13, 31 for the } I_{CC}.)$$

Thus, the maximum load current $I_{OUT\text{max}}$ for the applied voltage V_{CC} can be calculated during the thermal design process. The following method is also used to calculate the junction temperature T_j .

$$T_j = P_c \times \theta_{jc} + T_c$$

T_a : Ambient Temperature
 T_c : Case Temperature
 T_j : Junction Temperature
 θ_{jc} : Thermal Resistance
 (Junction to Case)

●HTSOP-J8

■Calculation Example 1) with $T_a = 105^\circ\text{C}$ $V_{CC} = 13.5\text{ V}$, $V_{OUT} = 5.0\text{ V}$

$$I_{OUT} \leq \frac{1.06\text{ W} - 13.5\text{ V} \times I_{CC}}{8.5\text{ V}}$$

$$I_{OUT} \leq 125\text{ mA} \quad (I_{CC} = 45\text{ }\mu\text{A})$$

$$\left[\begin{array}{l} \text{IC stand alone } \theta_{ja} = 43.1^\circ\text{C/W} \rightarrow -23\text{ mW}/^\circ\text{C} \\ 25^\circ\text{C} = 2.9\text{ W} \rightarrow 105^\circ\text{C} = 1.06\text{ W} \end{array} \right]$$

At $T_a = 105^\circ\text{C}$ with Figure 44 ② condition, the calculation shows that 125 mA of output current is possible at 8.5 V potential difference across input and output.

The thermal calculation shown above should be taken into consideration during the thermal design in order to keep the whole operating temperature range within the power dissipation range.

In the event of shorting (i.e. V_{OUT} and GND pins are shorted) the power consumption P_c of the IC can be calculated as follows:

$$P_c = V_{CC} \times (I_{CC} + I_{\text{short}}) \quad (\text{Refer to Figure 10, 28 for the } I_{\text{short}}) \quad I_{\text{short}} : \text{Short Current}$$

■Calculation Example 2) with $T_c(\text{bottom}) = 80^\circ\text{C}$, $V_{CC} = 13.5\text{ V}$, $V_{OUT} = 5.0\text{ V}$, $I_{OUT} = 80\text{ mA}$

At $T_c(\text{bottom}) = 80^\circ\text{C}$ with Figure 44 ② condition, the power consumption P_c of the IC can be calculated as follows:

$$P_c = (V_{CC} - V_{OUT}) \times I_{OUT} + V_{CC} \times I_{CC}$$

$$P_c = (13.5\text{ V} - 5.0\text{ V}) \times 80\text{ mA} + 13.5\text{ V} \times I_{CC}$$

$$P_c = 0.681\text{ W} \quad (I_{CC} = 45\text{ }\mu\text{A})$$

At the power consumption P_c is 0.681 W, the junction temperature T_j can be calculated as follows:

$$T_j = P_c \times \theta_{jc} + T_c$$

$$T_j = 0.681\text{ W} \times \theta_{jc} + 80^\circ\text{C}$$

$$T_j = 86.8^\circ\text{C} \quad (\theta_{jc}(\text{bottom}) = 10^\circ\text{C/W})$$

The junction temperature is 86.8°C , at above condition.

The thermal calculation shown above should be taken into consideration during the thermal design in order to keep the whole operating temperature range within $T_j \leq 150^\circ\text{C}$.

●SOT223-4F

■Calculation Example 1) with $T_a = 105\text{ }^\circ\text{C}$ $V_{CC} = 13.5\text{ V}$, $V_{OUT} = 5.0\text{ V}$

$$I_{OUT} \leq \frac{0.54\text{ W} - 13.5\text{ V} \times I_{CC}}{8.5\text{ V}}$$

$$I_{OUT} \leq 63\text{ mA} \quad (I_{CC}: 45\text{ }\mu\text{A})$$

$$\left(\begin{array}{l} \text{IC stand alone } \theta_{ja} = 83.3\text{ }^\circ\text{C/W} \rightarrow -12\text{ mW/}^\circ\text{C} \\ 25\text{ }^\circ\text{C} = 1.50\text{ W} \rightarrow 105\text{ }^\circ\text{C} = 0.54\text{ W} \end{array} \right)$$

At $T_a = 105\text{ }^\circ\text{C}$ with Figure 45 ② condition, the calculation shows that 63 mA of output current is possible at 8.5 V potential difference across input and output.

The thermal calculation shown above should be taken into consideration during the thermal design in order to keep the whole operating temperature range within the power dissipation range.

In the event of shorting (i.e. V_{OUT} and GND pins are shorted) the power consumption P_c of the IC can be calculated as follows:

$$P_c = V_{CC} \times (I_{CC} + I_{short}) \quad (\text{Refer to Figure 10, 28 for the } I_{short})$$

■Calculation Example 2) with $T_c(\text{bottom}) = 92\text{ }^\circ\text{C}$, $V_{CC} = 13.5\text{ V}$, $V_{OUT} = 5.0\text{ V}$, $I_{OUT} = 80\text{ mA}$

At $T_c(\text{bottom}) = 92\text{ }^\circ\text{C}$ with Figure 45 ② condition, the power consumption P_c of the IC can be calculated as follows:

$$P_c = (V_{CC} - V_{OUT}) \times I_{OUT} + V_{CC} \times I_{CC}$$

$$P_c = (13.5\text{ V} - 5.0\text{ V}) \times 80\text{ mA} + 13.5\text{ V} \times I_{CC}$$

$$P_c = 0.681\text{ W} \quad (I_{CC} = 45\text{ }\mu\text{A})$$

At the power consumption P_c is 0.681 W, the junction temperature T_j can be calculated as follows:

$$T_j = P_c \times \theta_{jc} + T_c$$

$$T_j = 0.681\text{ W} \times \theta_{jc} + 92\text{ }^\circ\text{C}$$

$$T_j = 103.6\text{ }^\circ\text{C} \quad (\theta_{jc}(\text{bottom}) = 17\text{ }^\circ\text{C/W})$$

The junction temperature is 103.6 °C, at above condition.

The thermal calculation shown above should be taken into consideration during the thermal design in order to keep the whole operating temperature range within $T_j \leq 150\text{ }^\circ\text{C}$.

● Application Examples

- Applying positive surge to the VCC pin

If the possibility exists that surges higher than 45 V will be applied to the VCC pin, a Zener Diode should be placed between the VCC pin and GND pin as shown in the figure below.

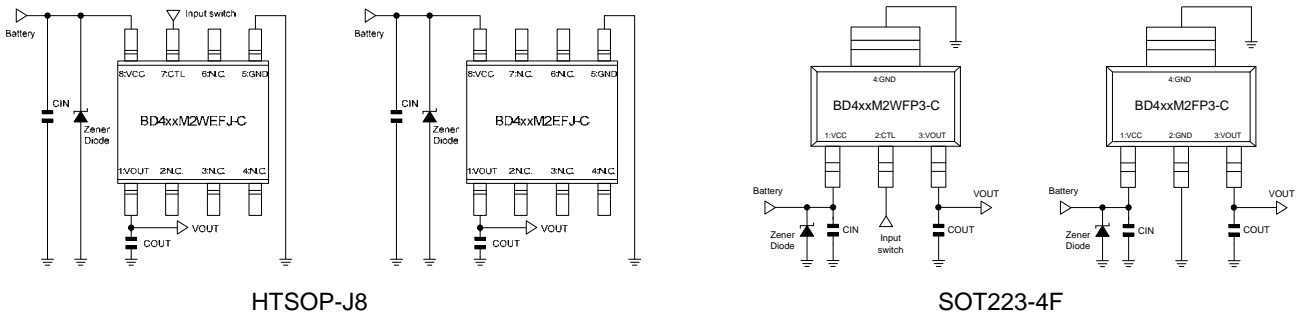

Figure 46. Sample Application Circuit 1

- Applying negative surge to the VCC pin

If the possibility exists that negative surges lower than the GND are applied to the VCC pin, a Shottky Diode should be placed between the VCC pin and GND pin as shown in the figure below.

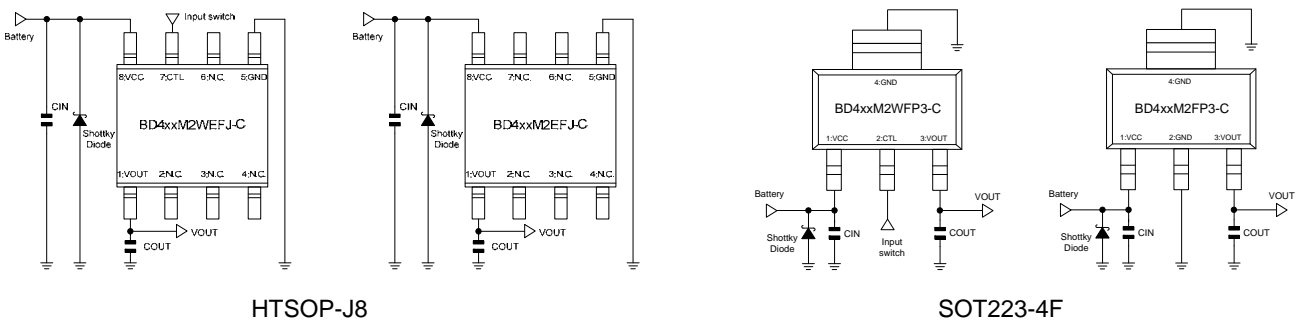

Figure 47. Sample Application Circuit 2

- Implementing a Protection Diode

If the possibility exists that a large inductive load is connected to the output pin resulting in back-EMF at time of startup and shutdown, a protection diode should be placed as shown in the figure below.

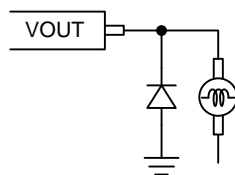

Figure 48. Sample Application Circuit 3

● I/O Equivalence Circuit

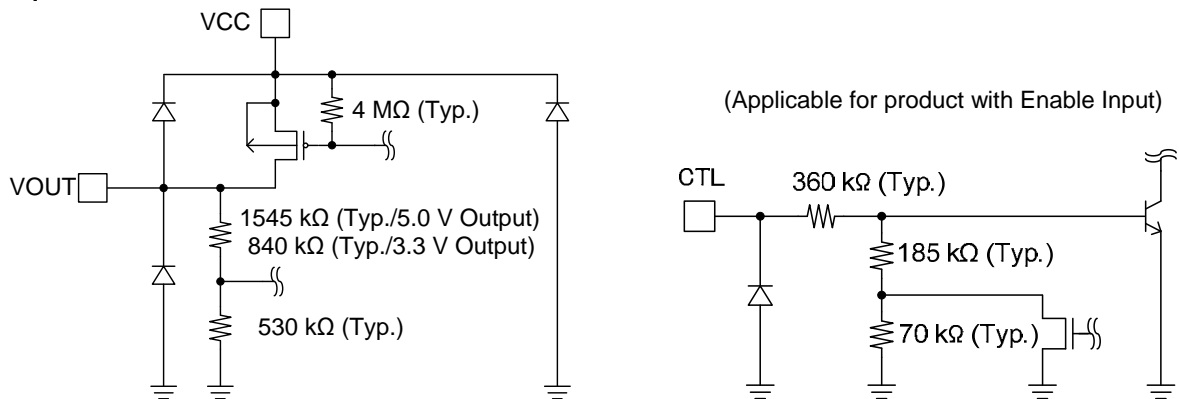

Figure 49. Input / Output Equivalence Circuit

●Operational Notes

1) Absolute Maximum Ratings

Exceeding the absolute maximum rating for supply voltage, operating temperature or other parameters can result in damages to or destruction of the chip. In this event it also becomes impossible to determine the cause of the damage (e.g. short circuit, open circuit, etc.). Therefore, if any special mode is being considered with values expected to exceed the absolute maximum ratings, implementing physical safety measures, such as adding fuses, should be considered.

2) The electrical characteristics given in this specification may be influenced by conditions such as temperature, supply voltage and external components. Transient characteristics should be sufficiently verified.

3) GND Electric Potential

Keep the GND pin potential at the lowest (minimum) level under any operating condition. Furthermore, ensure that, including the transient, none of the pin's voltages are less than the GND pin voltage.

4) GND Wiring Pattern

When both a small-signal GND and a high current GND are present, single-point grounding (at the set standard point) is recommended. This in order to separate the small-signal and high current patterns and to ensure that voltage changes stemming from the wiring resistance and high current do not cause any voltage change in the small-signal GND. Similarly, care must be taken to avoid wiring pattern fluctuations in any connected external component GND.

5) Inter-Pin Shorting and Mounting Errors

Ensure that when mounting the IC on the PCB the direction and position are correct. Incorrect mounting may result in damaging the IC. Also, shorts caused by dust entering between the output, input and GND pin may result in damaging the IC.

6) Inspection Using the Set Board

The IC needs to be discharged after each inspection process as, while using the set board for inspection, connecting a capacitor to a low-impedance pin may cause stress to the IC. As a protection from static electricity, ensure that the assembly setup is grounded and take sufficient caution with transportation and storage. Also, make sure to turn off the power supply when connecting and disconnecting the inspection equipment.

7) Power Dissipation (Pd)

Should by any chance the power dissipation rating be exceeded the rise in temperature of the chip may result in deterioration of the properties of the chip. The absolute maximum rating of the Pd stated in this specification is when the IC is mounted on a 114.3mm x 76.2mm x 1.6mm glass epoxy board. In case of exceeding this absolute maximum rating, increase the board size and copper area to prevent exceeding the Pd rating.

8) Thermal Design

The power dissipation under actual operating conditions should be taken into consideration and a sufficient margin should be allowed for in the thermal design. On the reverse side of the package this product has an exposed heat pad for improving the heat dissipation. Use both the front and reverse side of the PCB to increase the heat dissipation pattern as far as possible. The amount of heat generated depends on the voltage difference across the input and output, load current, and bias current. Therefore, when actually using the chip, ensure that the generated heat does not exceed the Pd rating.

(Tjmax: maximum junction temperature = 150°C, Ta: Ambient Temperature (°C), θja: Junction-to-Ambient Thermal Resistance (°C/W), Pd: Power Dissipation Rating (W), Pc: Power Consumption (W), VCC: Supply Voltage, VOUT: Output Voltage, IOU: Output Current, Icc: Circuit Current)

$$\begin{array}{ll} \text{Power Dissipation Rating} & Pd (W) = (T_{jmax} - T_a) / \theta_{ja} \\ \text{Power Consumption} & Pc (W) = (VCC - VOUT) \times IOU + VCC \times Icc \end{array}$$

9) Overcurrent Protection Circuit

This IC incorporates an integrated overcurrent protection circuit that is activated when the load is shorted. This protection circuit is effective in preventing damage due to sudden and unexpected incidents. However, the IC should not be used in applications characterized by continuous operation or transitioning of the protection circuit.

10) Thermal Shut Down (TSD)

This IC incorporates an integrated thermal shutdown circuit to prevent heat damage to the IC. Normal operation should be within the power dissipation rating, if however the rating is exceeded for a continued period, the junction temperature (Tj) will rise and the TSD circuit will be activated and turn all output pins OFF. After the Tj falls below the TSD threshold the circuits are automatically restored to normal operation.

Note that the TSD circuit operates in a situation that exceeds the absolute maximum ratings and therefore, under no circumstances, should the TSD circuit be used in a set design or for any purpose other than protecting the IC from heat damage.

11) In some applications, the VCC and pin potential might be reversed, possibly resulting in circuit internal damage or damage to the elements. For example, while the external capacitor is charged, the VCC shorts to the GND. Use a capacitor with a capacitance with less than 1000 μF . We also recommend using reverse polarity diodes in series or a bypass between all pins and the VCC pin.

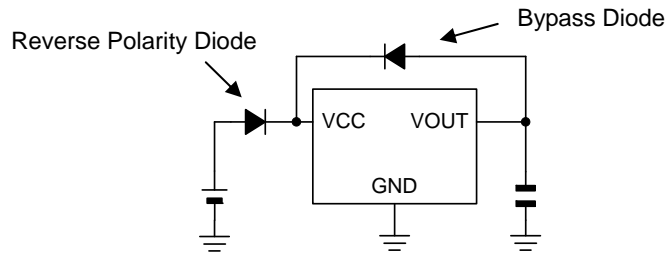

Figure 50.

12) This monolithic IC contains P+ isolation and P substrate layers between adjacent elements in order to keep them isolated. P/N junctions are formed at the intersection of these P layers with the N layers of other elements to create a variety of parasitic elements.

For example, in case a resistor and a transistor are connected to the pins as shown in the figure below then:

○The P/N junction functions as a parasitic diode when $\text{GND} > \text{pin A}$ for the resistor, or $\text{GND} > \text{pin B}$ for the transistor.

○Also, when $\text{GND} > \text{pin B}$ for the transistor (NPN), the parasitic diode described above combines with the N layer of the other adjacent elements to operate as a parasitic NPN transistor.

Parasitic diodes inevitably occur in the structure of the IC. Their operation can result in mutual interference between circuits and can cause malfunctions and, in turn, physical damage to or destruction of the chip. Therefore do not employ any method in which parasitic diodes can operate such as applying a voltage to an input pin that is lower than the (P substrate) GND.

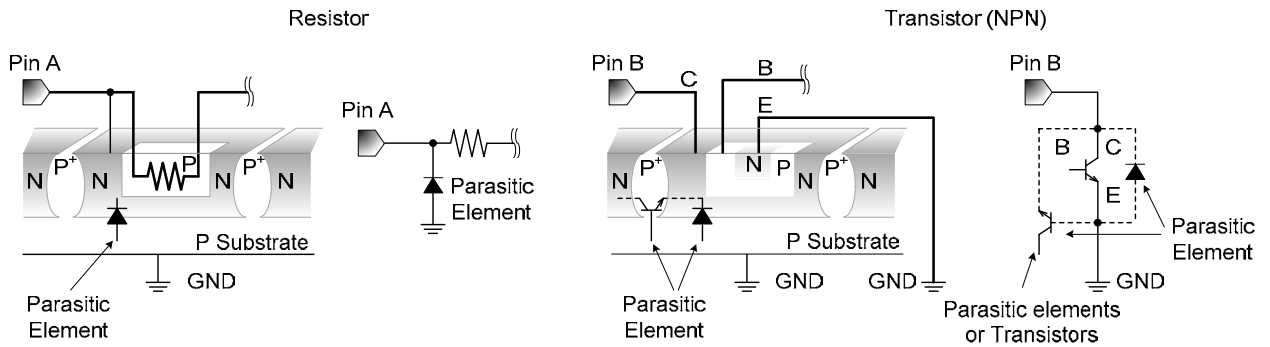
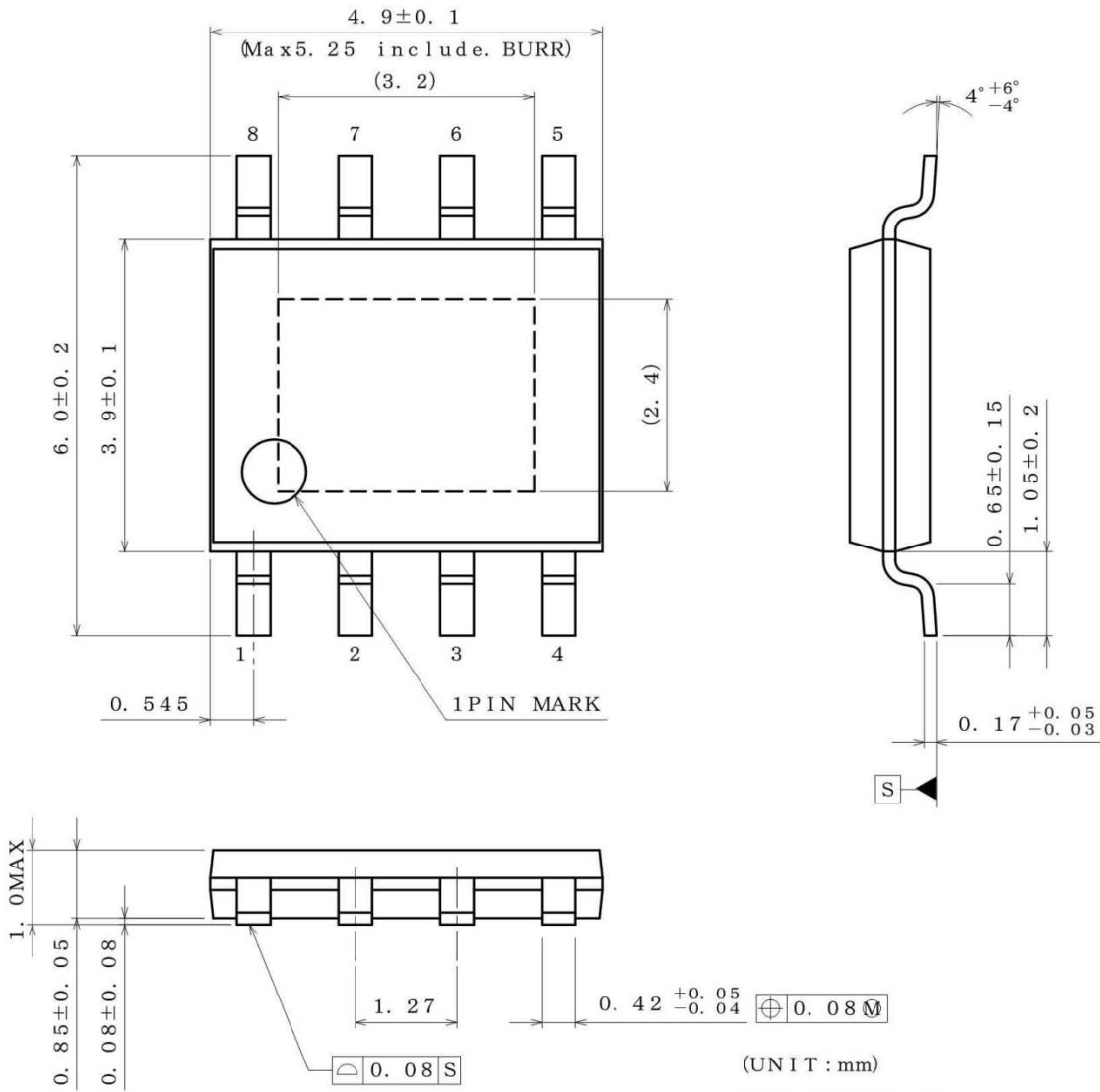

Figure 51.

●Physical Dimension, Tape and Reel Information (HTSOP-J8)

Package Name	HTSOP-J8
--------------	----------



(UNIT : mm)
 PKG : HTSOP-J8
 Drawing No. EX169-5002-2

<Tape and Reel information>

Tape	Embossed carrier tape
Quantity	2500pcs
Direction of feed	E2 (The direction is the 1pin of product is at the upper left when you hold reel on the left hand and you pull out the tape on the right hand)

1pin
 *Order quantity needs to be multiple of the minimum quantity.

●Physical Dimension, Tape and Reel Information (SOT223-4F)

Package Name	SOT223-4F
--------------	-----------

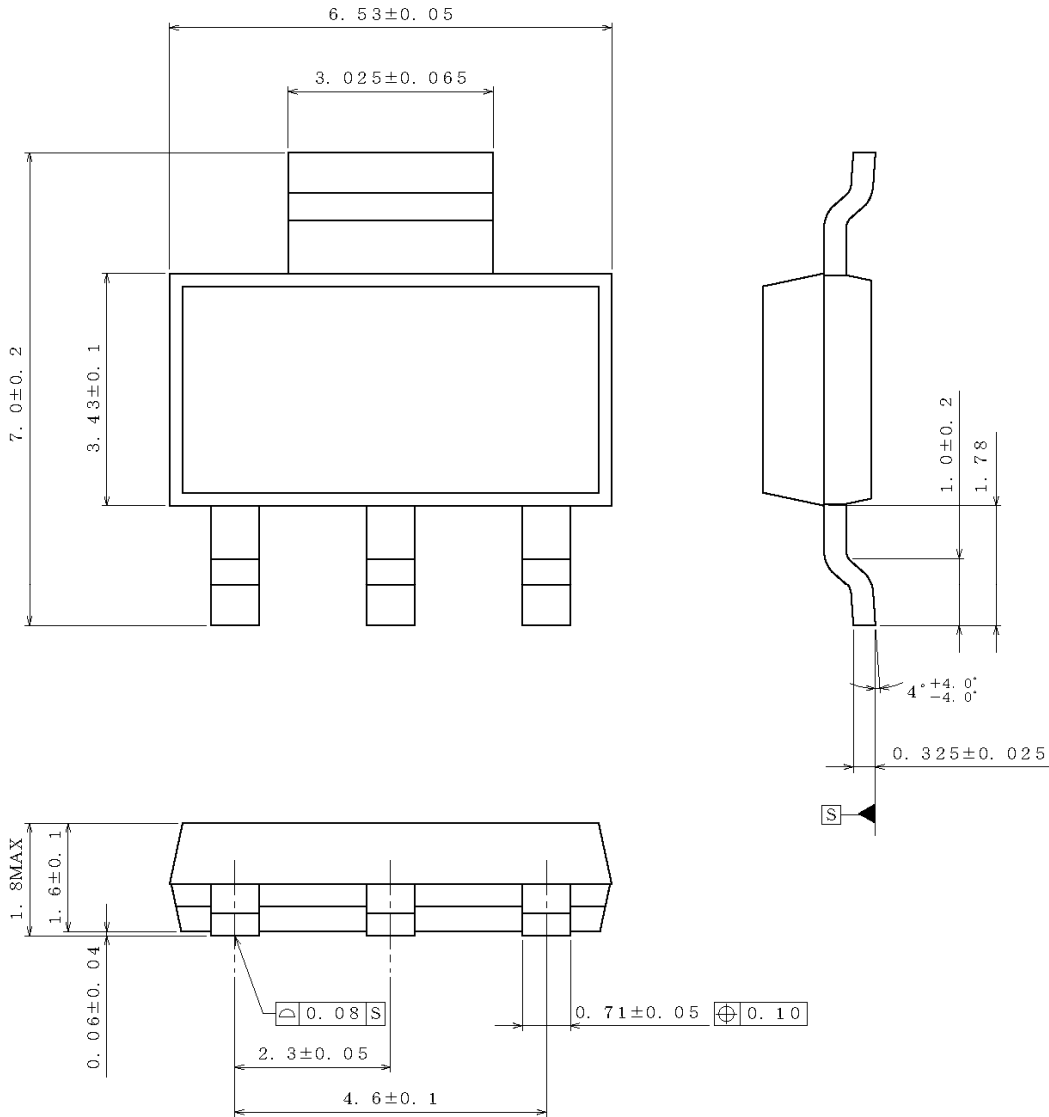

(UNIT:mm)

Drawing No. EX561-50C1

< Tape and Reel Information >

Tape	Embossed carrier tape
Quantity	2000pcs
Direction of feed	E2 (The direction is the 1 pin of product is at the lower left when you hold reel on the left hand and you pull out the tape on the right hand)

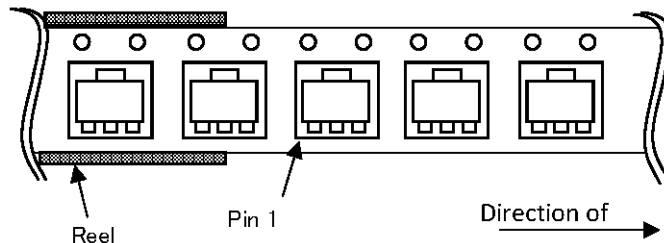

●Marking Diagrams (Top View)

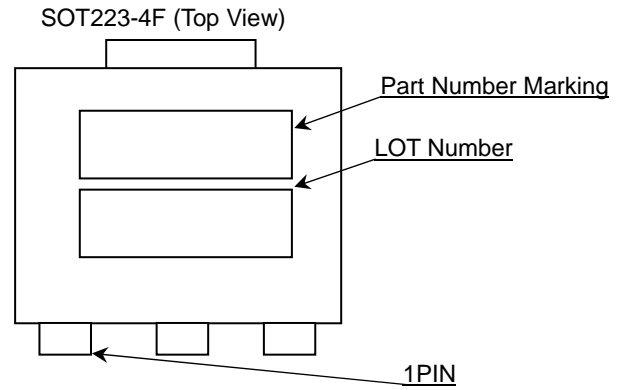
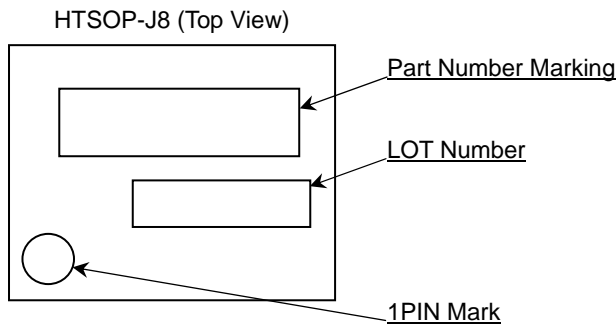

Part Number Marking	Output Voltage [V]	Enable Input ^{*1}
433M2W	3.3	○
450M2W	5.0	○
433M2	3.3	—
450M2	5.0	—

*1 ○: Includes Enable Input
 —: Not includes Enable Input

Part Number Marking	Output Voltage [V]	Enable Input ^{*1}
433M2W	3.3	○
450M2W	5.0	○
433M2	3.3	—
450M2	5.0	—

*1 ○: Includes Enable Input
 —: Not includes Enable Input

●Revision History

Date	Revision	Changes
05.Dec.2012	001	New Release (BD450M2WEFJ-C, BD450M2EFJ-C)
15.Jan.2013	002	Additional Entry (BD4xxM2-C Series)
29.Oct.2013	003	P.1 , P.3 Figure 3, P.4, P.5 Figure 4, P.9, P.13, P.23, P.24, P.26, P.29, P.30 Improve the explanation and corrected type. P.28, P.30 Improve the correct figure number because of sequence. Before) Figure 48, 49, 50, 51, 52, 53. After) Figure 46, 47, 48, 49, 50, 51.

Notice

Precaution on using ROHM Products

- If you intend to use our Products in devices requiring extremely high reliability (such as medical equipment ^(Note 1), aircraft/spacecraft, nuclear power controllers, etc.) and whose malfunction or failure may cause loss of human life, bodily injury or serious damage to property ("Specific Applications"), please consult with the ROHM sales representative in advance. Unless otherwise agreed in writing by ROHM in advance, ROHM shall not be in any way responsible or liable for any damages, expenses or losses incurred by you or third parties arising from the use of any ROHM's Products for Specific Applications.

(Note1) Medical Equipment Classification of the Specific Applications

JAPAN	USA	EU	CHINA
CLASS III	CLASS III	CLASS II b	CLASS III
CLASS IV		CLASS III	

- ROHM designs and manufactures its Products subject to strict quality control system. However, semiconductor products can fail or malfunction at a certain rate. Please be sure to implement, at your own responsibilities, adequate safety measures including but not limited to fail-safe design against the physical injury, damage to any property, which a failure or malfunction of our Products may cause. The following are examples of safety measures:
 - Installation of protection circuits or other protective devices to improve system safety
 - Installation of redundant circuits to reduce the impact of single or multiple circuit failure
- Our Products are not designed under any special or extraordinary environments or conditions, as exemplified below. Accordingly, ROHM shall not be in any way responsible or liable for any damages, expenses or losses arising from the use of any ROHM's Products under any special or extraordinary environments or conditions. If you intend to use our Products under any special or extraordinary environments or conditions (as exemplified below), your independent verification and confirmation of product performance, reliability, etc, prior to use, must be necessary:
 - Use of our Products in any types of liquid, including water, oils, chemicals, and organic solvents
 - Use of our Products outdoors or in places where the Products are exposed to direct sunlight or dust
 - Use of our Products in places where the Products are exposed to sea wind or corrosive gases, including Cl₂, H₂S, NH₃, SO₂, and NO₂
 - Use of our Products in places where the Products are exposed to static electricity or electromagnetic waves
 - Use of our Products in proximity to heat-producing components, plastic cords, or other flammable items
 - Sealing or coating our Products with resin or other coating materials
 - Use of our Products without cleaning residue of flux (even if you use no-clean type fluxes, cleaning residue of flux is recommended); or Washing our Products by using water or water-soluble cleaning agents for cleaning residue after soldering
 - Use of the Products in places subject to dew condensation
- The Products are not subject to radiation-proof design.
- Please verify and confirm characteristics of the final or mounted products in using the Products.
- In particular, if a transient load (a large amount of load applied in a short period of time, such as pulse. is applied, confirmation of performance characteristics after on-board mounting is strongly recommended. Avoid applying power exceeding normal rated power; exceeding the power rating under steady-state loading condition may negatively affect product performance and reliability.
- De-rate Power Dissipation (Pd) depending on Ambient temperature (Ta). When used in sealed area, confirm the actual ambient temperature.
- Confirm that operation temperature is within the specified range described in the product specification.
- ROHM shall not be in any way responsible or liable for failure induced under deviant condition from what is defined in this document.

Precaution for Mounting / Circuit board design

- When a highly active halogenous (chlorine, bromine, etc.) flux is used, the residue of flux may negatively affect product performance and reliability.
- In principle, the reflow soldering method must be used; if flow soldering method is preferred, please consult with the ROHM representative in advance.

For details, please refer to ROHM Mounting specification

Precautions Regarding Application Examples and External Circuits

1. If change is made to the constant of an external circuit, please allow a sufficient margin considering variations of the characteristics of the Products and external components, including transient characteristics, as well as static characteristics.
2. You agree that application notes, reference designs, and associated data and information contained in this document are presented only as guidance for Products use. Therefore, in case you use such information, you are solely responsible for it and you must exercise your own independent verification and judgment in the use of such information contained in this document. ROHM shall not be in any way responsible or liable for any damages, expenses or losses incurred by you or third parties arising from the use of such information.

Precaution for Electrostatic

This Product is electrostatic sensitive product, which may be damaged due to electrostatic discharge. Please take proper caution in your manufacturing process and storage so that voltage exceeding the Products maximum rating will not be applied to Products. Please take special care under dry condition (e.g. Grounding of human body / equipment / solder iron, isolation from charged objects, setting of Ionizer, friction prevention and temperature / humidity control).

Precaution for Storage / Transportation

1. Product performance and soldered connections may deteriorate if the Products are stored in the places where:
 - [a] the Products are exposed to sea winds or corrosive gases, including Cl₂, H₂S, NH₃, SO₂, and NO₂
 - [b] the temperature or humidity exceeds those recommended by ROHM
 - [c] the Products are exposed to direct sunshine or condensation
 - [d] the Products are exposed to high Electrostatic
2. Even under ROHM recommended storage condition, solderability of products out of recommended storage time period may be degraded. It is strongly recommended to confirm solderability before using Products of which storage time is exceeding the recommended storage time period.
3. Store / transport cartons in the correct direction, which is indicated on a carton with a symbol. Otherwise bent leads may occur due to excessive stress applied when dropping of a carton.
4. Use Products within the specified time after opening a humidity barrier bag. Baking is required before using Products of which storage time is exceeding the recommended storage time period.

Precaution for Product Label

QR code printed on ROHM Products label is for ROHM's internal use only.

Precaution for Disposition

When disposing Products please dispose them properly using an authorized industry waste company.

Precaution for Foreign Exchange and Foreign Trade act

Since our Products might fall under controlled goods prescribed by the applicable foreign exchange and foreign trade act, please consult with ROHM representative in case of export.

Precaution Regarding Intellectual Property Rights

1. All information and data including but not limited to application example contained in this document is for reference only. ROHM does not warrant that foregoing information or data will not infringe any intellectual property rights or any other rights of any third party regarding such information or data. ROHM shall not be in any way responsible or liable for infringement of any intellectual property rights or other damages arising from use of such information or data.:
2. No license, expressly or implied, is granted hereby under any intellectual property rights or other rights of ROHM or any third parties with respect to the information contained in this document.

Other Precaution

1. This document may not be reprinted or reproduced, in whole or in part, without prior written consent of ROHM.
2. The Products may not be disassembled, converted, modified, reproduced or otherwise changed without prior written consent of ROHM.
3. In no event shall you use in any way whatsoever the Products and the related technical information contained in the Products or this document for any military purposes, including but not limited to, the development of mass-destruction weapons.
4. The proper names of companies or products described in this document are trademarks or registered trademarks of ROHM, its affiliated companies or third parties.

General Precaution

1. Before you use our Products, you are requested to carefully read this document and fully understand its contents. ROHM shall not be in any way responsible or liable for failure, malfunction or accident arising from the use of any ROHM's Products against warning, caution or note contained in this document.
2. All information contained in this document is current as of the issuing date and subject to change without any prior notice. Before purchasing or using ROHM's Products, please confirm the latest information with a ROHM sales representative.
3. The information contained in this document is provided on an "as is" basis and ROHM does not warrant that all information contained in this document is accurate and/or error-free. ROHM shall not be in any way responsible or liable for any damages, expenses or losses incurred by you or third parties resulting from inaccuracy or errors of or concerning such information.



Компания «ЭлектроПласт» предлагает заключение долгосрочных отношений при поставках импортных электронных компонентов на взаимовыгодных условиях!

Наши преимущества:

- Оперативные поставки широкого спектра электронных компонентов отечественного и импортного производства напрямую от производителей и с крупнейших мировых складов;
- Поставка более 17-ти миллионов наименований электронных компонентов;
- Поставка сложных, дефицитных, либо снятых с производства позиций;
- Оперативные сроки поставки под заказ (от 5 рабочих дней);
- Экспресс доставка в любую точку России;
- Техническая поддержка проекта, помощь в подборе аналогов, поставка прототипов;
- Система менеджмента качества сертифицирована по Международному стандарту ISO 9001;
- Лицензия ФСБ на осуществление работ с использованием сведений, составляющих государственную тайну;
- Поставка специализированных компонентов (Xilinx, Altera, Analog Devices, Intersil, Interpoint, Microsemi, Aeroflex, Peregrine, Syfer, Eurofarad, Texas Instrument, Miteq, Cobham, E2V, MA-COM, Hittite, Mini-Circuits, General Dynamics и др.);

Помимо этого, одним из направлений компании «ЭлектроПласт» является направление «Источники питания». Мы предлагаем Вам помощь Конструкторского отдела:

- Подбор оптимального решения, техническое обоснование при выборе компонента;
- Подбор аналогов;
- Консультации по применению компонента;
- Поставка образцов и прототипов;
- Техническая поддержка проекта;
- Защита от снятия компонента с производства.



Как с нами связаться

Телефон: 8 (812) 309 58 32 (многоканальный)

Факс: 8 (812) 320-02-42

Электронная почта: org@eplast1.ru

Адрес: 198099, г. Санкт-Петербург, ул. Калинина, дом 2, корпус 4, литера А.