

Amphenol  
FCi

© 2016 AFci

|                                       |                     |         |              |            |                                |    |          |     |                        |          |
|---------------------------------------|---------------------|---------|--------------|------------|--------------------------------|----|----------|-----|------------------------|----------|
| spec ref                              | -                   | dr      | Hai-Ling Liu | 2016/03/09 | projection                     | MM | size     | A2  | scale                  | 1:1      |
| tolerance std                         | ISO 406<br>ISO 1101 | eng     | Sunny2 Liu   | 2016/06/16 |                                |    | ecn no   | -   | rel level              | Released |
| TOLERANCES UNLESS OTHERWISE SPECIFIED |                     | chr     | Terris Liu   | 2016/06/16 |                                |    |          |     |                        |          |
| surface                               | ASME Y14.5          | linear  | 0.X          | ±0.5       | product family                 |    | 10139003 | rev | A                      |          |
|                                       |                     |         | 0.XX         | ±0.25      | HPCE VT-ENHANCED WALLS         |    |          |     | Product - Customer Drw |          |
|                                       |                     |         | 0.XXX        | ±0.10      | P+S - UNIVERSAL DRAWING LOW HF |    |          |     | sheet 1 of 4           |          |
|                                       |                     | angular | 0°           | ±2°        | cat. no.                       |    |          |     | STATUS:Released        |          |

PDS: Rev :A

STATUS:Released

Printed: Jun 16, 2016

| CONTACT TYPE   | TOP LAYER DESCRIPTION | TABLE 1 (HPCE / SOLDER TAILS)<br>PLATED THROUGH-HOLE REQUIREMENTS |                  |                    |               |                        |
|----------------|-----------------------|---|------------------|--------------------|---------------|------------------------|
|                |                       | DRILLED HOLE DIAMETER   | COPPER THICKNESS | TIN-LEAD THICKNESS | TIN THICKNESS | FINISHED HOLE DIAMETER |
| POWER & SIGNAL | TIN-LEAD              | 1.10-1.16 (1.15 DRILL)  | 0.025 - 0.050    | 0.005 - 0.015      | --            | 0.94 - 1.10            |
|                | IMMERSION TIN         | 1.10-1.16 (1.15 DRILL)  | 0.025 - 0.050    | --                 | 0.9 - 1.5um   | 0.94 - 1.10            |
|                | COPPER                | 1.10-1.16 (1.15 DRILL)  | 0.025 - 0.050    | --                 | --            | 0.94 - 1.10            |

| CONTACT TYPE   | TOP LAYER DESCRIPTION | TABLE 2 (HPCE / PRESS-FIT TAILS)<br>PLATED THROUGH-HOLE REQUIREMENTS |                  |                    |               |                        |
|----------------|-----------------------|--|------------------|--------------------|---------------|------------------------|
|                |                       | DRILLED HOLE DIAMETER  | COPPER THICKNESS | TIN-LEAD THICKNESS | TIN THICKNESS | FINISHED HOLE DIAMETER |
| POWER & SIGNAL | TIN-LEAD              | 0.81-0.86 (0.85 DRILL)   | 0.025 - 0.050    | 0.005 - 0.015      | --            | 0.65 - 0.80            |
|                | IMMERSION TIN         | 0.81-0.86 (0.85 DRILL)   | 0.025 - 0.050    | --                 | 0.9 - 1.5um   | 0.70 - 0.80            |
|                | COPPER                | 0.81-0.86 (0.85 DRILL)   | 0.025 - 0.050    | --                 | --            | 0.70 - 0.80            |

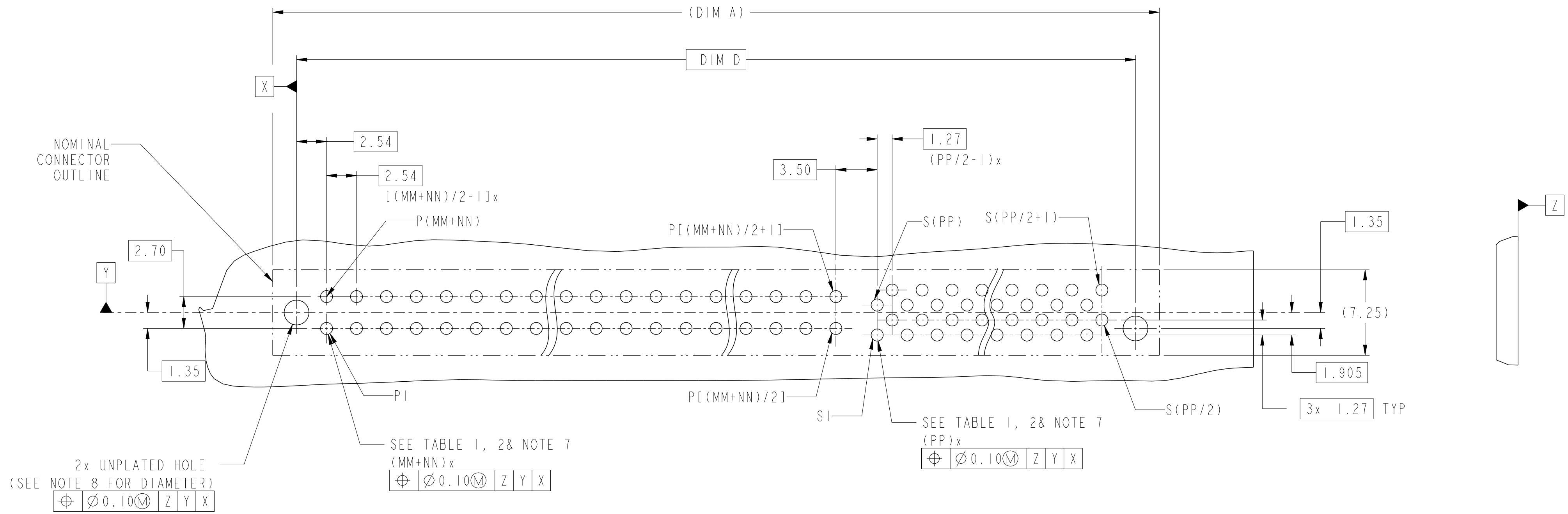

**RECOMMENDED PCB LAYOUT**  
DIMENSION TOLERANCE IS ± 0.05 mm

|                                       |                     |        |                |            |   |       |          |                        |           |              |     |
|---------------------------------------|---------------------|--------|----------------|------------|---|-------|----------|------------------------|-----------|--------------|-----|
| spec ref                              | -                   | dr     | Hai-Ling Liu   | 2016/03/09 | projection  | MM    | size     | A2                     | scale     | 1:1          |     |
| tolerance std                         | ISO 406<br>ISO 1101 | eng    | Sunny2 Liu     | 2016/06/16 |   |       | ecn no   | -                      | rel level | Released     |     |
| TOLERANCES UNLESS OTHERWISE SPECIFIED |                     | chr    | Terris Liu     | 2016/06/16 |   |       |          |                        |           |              |     |
|                                       |                     | appr   | Pai-Ming Zheng | 2016/06/16 |   |       |          |                        |           |              |     |
| surface                               | ASME Y14.5          | linear | 0.X            | ±0.5       | 0.XX  | ±0.25 | 0.XXX    | ±0.10                  | angular   | 0°           | ±2° |
|                                       |                     |        |                |            | <b>HPCE VT-ENHANCED WALLS</b><br>P+S - UNIVERSAL DRAWING LOW HF |       | cat. no. | Product - Customer Drw |           | sheet 2 of 4 |     |

Amphenol FCI

© 2016 APCI

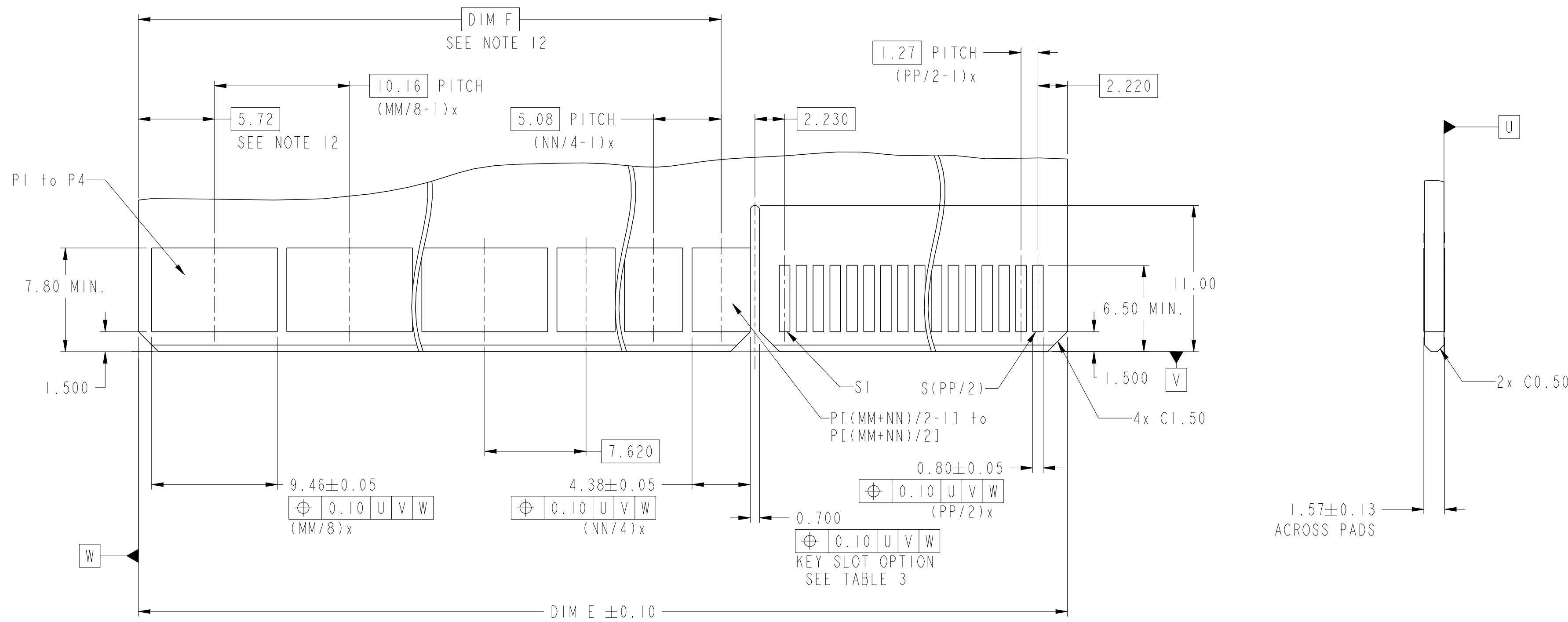

RECOMMENDED EDGE CARD LAYOUT  
DIMENSION TOLERANCE IS ± 0.05 mm

|                                       |                     |              |                |                        |            |                                |        |                       |                        |              |     |
|---------------------------------------|---------------------|--------------|----------------|------------------------|------------|--------------------------------|--------|-----------------------|------------------------|--------------|-----|
| spec ref                              | -                   | dr           | Hai-Ling Liu   | 2016/03/09             | projection | MM                             | size   | A2                    | scale                  | 1:1          |     |
| tolerance std                         | ISO 406<br>ISO 1101 | eng          | Sunny2 Liu     | 2016/06/16             |            |                                | ecn no | -                     | rel level              | Released     |     |
| TOLERANCES UNLESS OTHERWISE SPECIFIED |                     | chr          | Terris Liu     | 2016/06/16             |            |                                |        |                       |                        |              |     |
|                                       |                     | appr         | Pai-Ming Zheng | 2016/06/16             |            |                                |        |                       |                        |              |     |
| surface                               | ASME Y14.5          | linear       | 0.X            | ±0.5                   | 0.XX       | ±0.25                          | 0.XXX  | ±0.10                 | angular                | 0°           | ±2° |
|                                       |                     | Amphenol FCI |                | HPCE VT-ENHANCED WALLS |            | P+S - UNIVERSAL DRAWING LOW HF |        | cat. no.              | Product - Customer Drw | sheet 3 of 4 |     |
|                                       |                     |              |                | PDS: Rev :A            |            | STATUS:Released                |        | Printed: Jun 16, 2016 |                        |              |     |

10139003

MM

NN

PP

H

LF

LOW HALOGEN FREE

|                         |     |    |     |    |
|-------------------------|-----|----|-----|----|
|                         | A   | B  | C   | D  |
| Polarization Key Option | Y   | Y  | N   | N  |
| Tail Type<br>Note 10    | STB | PF | STB | PF |

QUAD PWR BEAM QTY  
(NEXT TO LEFT END)

DUAL PWR BEAM QTY  
(NEXT TO SIGNAL)

SIGNAL CONTACT QTY

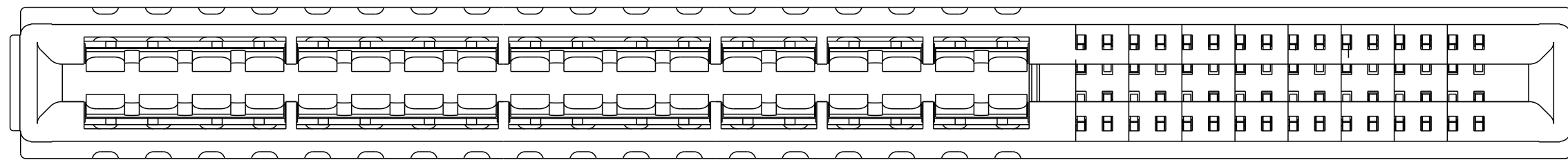

Example: The configuration above is 10139003241232BHLLF  
VERT Press fit 36P32S with polarization key. 24P is Quad beam contact, 12P is dual beam contact.

TABLE 3. PART NUMBER CODE. HPCE VERT P+S CONFIG

NOTES:

- CONNECTOR MATERIALS:  
HOUSING: HIGH TEMPERATURE THERMAL PLASTIC, BLACK  
UL 94V-0 COMPLIANT  
CONTACTS: HIGH PERFORMANCE COPPER ALLOY.
- CONTACT FINISH REF. GS-12-604 SECTION 5.2.
- PRODUCT SPECIFICATION: GS-12-604.
- APPLICATION SPECIFICATION: GS-20-128.
- PRODUCT MARKING ON HOUSING IN AREA SHOWN MEETS AFCI SPECIFICATION GS-24-007
- PACKAGING MEETS FCI SPECIFICATION GS-14-937.
- ALL HOLE SIZES ARE FINISHED HOLE SIZES.
- MOUNTING HOLES ARE UNPLATED  
Ø 2.40 +/- 0.1 FOR PRESS-FIT TAILS  
Ø 2.18 +/- 0.03 FOR SOLDER TAILS
- PRESS FIT APPLICATION TOOL DRAWING : 10119453.
- STB=SOLDER TO BOARD, 2.36MM PCB THICKNESS.  
PF=PRESS FIT, 1.57MM MINIMUM PCB THICKNESS.
- MAXIMUM OVERALL LENGTH IS 100mm.
- DIM IS NOT APPLICABLE IF NO 4 BEAM CONTACT OR 2 BEAM CONTACT.

| DIM   | TABLE 2. LENGTH FORMULAS.  |
|-------|--|
| DIM A | $(MM/8) \times 10.16 + (NN/4) \times 5.08 + (PP/2) \times 1.27 + 9.12$       |
| DIM B | DIM "A" - 5.00   |
| DIM C | DIM "A" - 0.94   |
| DIM D | DIM "A" - 4.04   |
| DIM E | DIM "A" - 5.30   |
| DIM F | $(MM/8-1) \times 10.16 + (NN/4-1) \times 5.08 + 13.34$ (WITH 4 BEAM CONTACT) |
|       | 3.18 (WITHOUT 4 BEAM CONTACT)  |

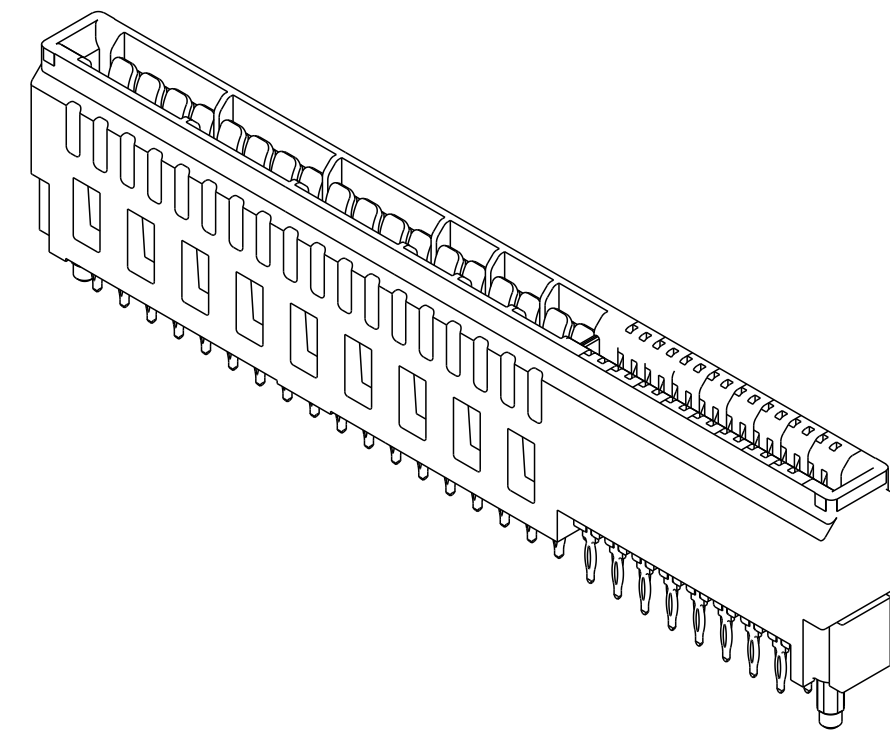

|                                       |                                       |      |                |            |            |    |          |                        |           |              |
|---------------------------------------|---------------------------------------|------|----------------|------------|------------|----|----------|------------------------|-----------|--------------|
| spec ref                              | -                                     | dr   | Hai-Ling Liu   | 2016/03/09 | projection | MM | size     | A2                     | scale     | 1:1          |
| tolerance std                         | ISO 406<br>ISO 1101                   | eng  | Sunny2 Liu     | 2016/06/16 |            |    | ecn no   | -                      | rel level | Released     |
| TOLERANCES UNLESS OTHERWISE SPECIFIED |                                       | chr  | Terris Liu     | 2016/06/16 |            |    |          |                        |           |              |
| surface                               | ASME Y14.5                            | appr | Pei-Ming Zheng | 2016/06/16 |            |    | cat. no. | Product - Customer Drw |           | sheet 4 of 4 |
| linear                                | 0.X ±0.5<br>0.XX ±0.25<br>0.XXX ±0.10 |      |                |            |            |    |          |                        |           |              |
| angular                               | 0° ±2°                                |      |                |            |            |    |          |                        |           |              |



Компания «ЭлектроПласт» предлагает заключение долгосрочных отношений при поставках импортных электронных компонентов на взаимовыгодных условиях!

Наши преимущества:

- Оперативные поставки широкого спектра электронных компонентов отечественного и импортного производства напрямую от производителей и с крупнейших мировых складов;
- Поставка более 17-ти миллионов наименований электронных компонентов;
- Поставка сложных, дефицитных, либо снятых с производства позиций;
- Оперативные сроки поставки под заказ (от 5 рабочих дней);
- Экспресс доставка в любую точку России;
- Техническая поддержка проекта, помощь в подборе аналогов, поставка прототипов;
- Система менеджмента качества сертифицирована по Международному стандарту ISO 9001;
- Лицензия ФСБ на осуществление работ с использованием сведений, составляющих государственную тайну;
- Поставка специализированных компонентов (Xilinx, Altera, Analog Devices, Intersil, Interpoint, Microsemi, Aeroflex, Peregrine, Syfer, Eurofarad, Texas Instrument, Miteq, Cobham, E2V, MA-COM, Hittite, Mini-Circuits, General Dynamics и др.);

Помимо этого, одним из направлений компании «ЭлектроПласт» является направление «Источники питания». Мы предлагаем Вам помощь Конструкторского отдела:

- Подбор оптимального решения, техническое обоснование при выборе компонента;
- Подбор аналогов;
- Консультации по применению компонента;
- Поставка образцов и прототипов;
- Техническая поддержка проекта;
- Защита от снятия компонента с производства.



#### Как с нами связаться

**Телефон:** 8 (812) 309 58 32 (многоканальный)

**Факс:** 8 (812) 320-02-42

**Электронная почта:** [org@eplast1.ru](mailto:org@eplast1.ru)

**Адрес:** 198099, г. Санкт-Петербург, ул. Калинина, дом 2, корпус 4, литера А.