

Piranha LEDs

LTL911VRKSA

LTL911VEKSA

LTL911VHKSA

LTL911VYKSA

LTL912VEKSA

LTL912VHKSA

LTL912VYKSA

**Selection Guide**

Part No.	Color	Φ_v (lm)	Va(deg.)	λ_d (nm)
LTL911VRKSA	Super Red	1.5	70	631
LTL911VEKSA	Red	2.0	70	624
LTL911VHKSA	Red-Orange	2.0	70	618
LTL911VYKSA	Amber	2.0	70	595
LTL912VEKSA	Red	2.0	50	624
LTL912VHKSA	Red-Orange	2.0	50	618
LTL912VYKSA	Amber	2.0	50	595

Benefits

- Fewer LEDs Required
- Lower lighting System Cost

Applications

- Signs and Signals
- Room Lighting



Features

- High Current Operation
- High Flux Output
- Low Thermal Resistance
- Low Profile
- Wide Viewing Angle
- Meet SAE/ ECE/ JIS Automotive Color Requirement
- Tube Package for Automatic Loading and Insertion Process

Description

These parts are designed for high current operation and high flux output applications. In order to solve the high temperature produced by the higher current operation, the package's design features better thermal management characteristics than other LED solutions coupled with an efficient optical design.

This package design allows the lighting designer to reduce the number of LEDs required as well as the overall lighting system cost. The low profile package can be easily coupled to reflectors or lenses to efficiently distribute light and provide the desired illuminated appearance. This product family employs the world's brightest red, red-orange, amber, blue, cyan, green, and white LED materials etc., which allow designers to match the color of popular lighting applications, such as automotive lighting and electronic signs.

Devices

Part No (LTL*)	Lens		Source	
	Color	Diffusion	Dice Source	Color
LTL911VRKSA	Water Clear	Non-Diffused	AllnGaP	Super Red
LTL911VEKSA	Water Clear	Non-Diffused	AllnGaP	Red
LTL911VHKSA	Water Clear	Non-Diffused	AllnGaP	Red-Orange
LTL911VYKSA	Water Clear	Non-Diffused	AllnGaP	Amber
LTL912VEKSA	Water Clear	Non-Diffused	AllnGaP	Red
LTL912VHKSA	Water Clear	Non-Diffused	AllnGaP	Red-Orange
LTL912VYKSA	Water Clear	Non-Diffused	AllnGaP	Amber

Package Dimensions

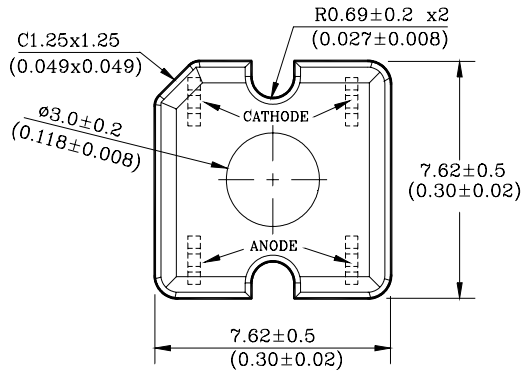

Part No.	H
LTL911XXXXX	1.50(0.059)
LTL912XXXXX	1.90(0.075)

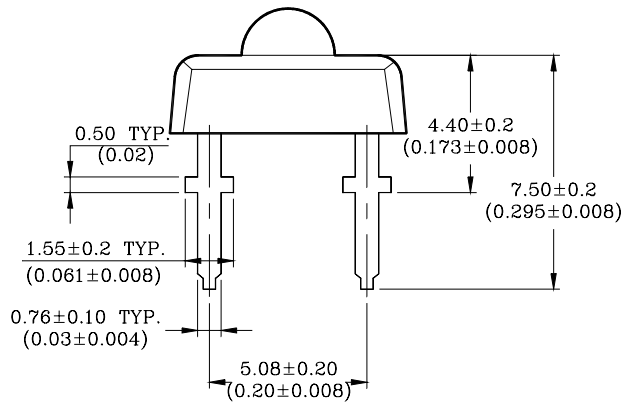
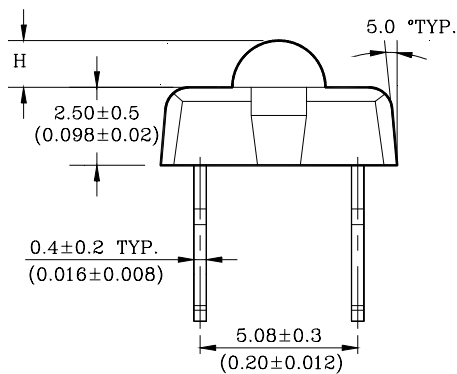

NOTES:

1. All dimensions are in millimeters (inches).
2. Protruded resin is 1.0mm(.04") max.
3. Lead spacing is measured where the leads emerge from the package.
4. Specifications are subject change to without notice.



LITE-ON TECHNOLOGY CORPORATION

Property of Lite-On Only

Absolute Maximum Ratings at $T_A=25^{\circ}\text{C}$

Parameter	Super Red	Red	Red-Orange	Amber	Unit
Power Dissipation	190	190	190	190	mW
Peak Forward Current (1/10 Duty Cycle, 0.1ms Pulse Width)	130	130	90	90	mA
Continuous Forward Current	70	70	70	70	mA
Derating Linear From 70°C	1.17	1.17	1.17	1.17	mA/ $^{\circ}\text{C}$
Reverse Voltage ($I_R = 100 \mu\text{A}$)	10	10	10	10	V
Operating Temperature Range	-40°C to $+100^{\circ}\text{C}$				
Storage Temperature Range	-55°C to $+100^{\circ}\text{C}$				
LED Junction Temperature	125°C				
Soldering Preheat Temperature Lead Soldering Temperature	100°C for 30 Seconds 260°C for 5 Seconds [1.5mm (.06") From Seating Plane]				

Notes:

1. Operation at currents below 10mA is not recommended.
2. Derating linear as shown in Fig. 3

Electrical / Optical Characteristics at TA=25°C

Parameter	Symbol	Part No.	Min.	Typ.	Max.	Unit	Test Condition
Total Flux <Note1>	Φ_V	LTL91xVRKSA LTL91xVEKSA LTL91xVHKSA LTL91xVYKSA	1.0 1.5 1.5 1.5	1.5 2.0 2.0 2.0		lm	IF=70mA
Luminous Intensity / Total Flux	I_v / Φ_V	LTL911VxKSA LTL912VxKSA		0.6 1.2		cd /lm	IF=70mA
Viewing Angle <Note2, Fig 5>	$2\theta_{1/2}$	LTL911VxKSA LTL912VxKSA		70 50		deg.	
Peak Emission Wavelength <Fig 1>	λ_P	LTL91xVRKSA LTL91xVEKSA LTL91xVHKSA LTL91xVYKSA		639 632 624 598		nm	IF=70mA
Dominant Wavelength <Note 3>	λ_d	LTL91xVRKSA LTL91xVEKSA LTL91xVHKSA LTL91xVYKSA		631 624 618 595		nm	IF=70mA
Spectral Line Half- Width	$\Delta\lambda$	LTL91xVRKSA LTL91xVEKSA LTL91xVHKSA LTL91xVYKSA		20 20 18 16		nm	
Forward Voltage	V _F		1.83	2.15	2.67	V	IF=70mA
Reverse Voltage	V _R		10	20		V	I _R = 100μA
Thermal resistance	R θ_{J-PIN}			160		°C/W	

- Note:
1. Φ_V is the total luminous flux output as measured with an integrating sphere.
 2. $\theta_{1/2}$ is the off-axis angle at which the luminous intensity is half the axial luminous intensity.
 3. The dominant wavelength, λ_d is derived from the CIE chromaticity diagram and represents the single wavelength which defines the color of the device.

Typical Electrical / Optical Characteristics Curves

(25°C Ambient Temperature Unless Otherwise Noted)

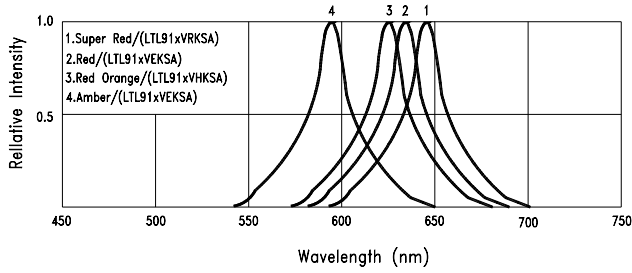

Fig.1 Relative Intensity v.s Wavelength

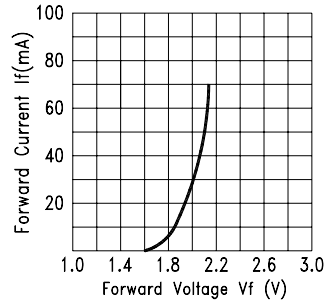

Fig.2 Forward Current v.s Forward Voltage

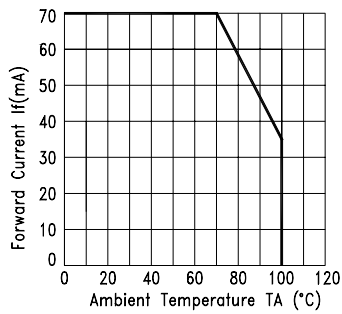

Fig.3 Forward Current v.s Ambient Temperature

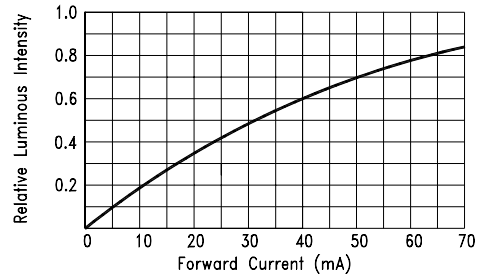

Fig.4 Relative Luminous Intensity v.s Forward Current

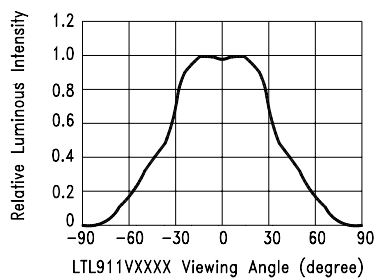

Fig.5-1 Relative Luminous Intensity v.s Off Axis Angle

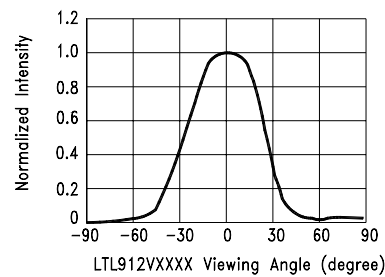

Fig.5-2 Relative Luminous Intensity v.s Off Axis Angle

Bin Code List For Reference

Category Code		
D	1	H2

Luminous Flux
(Light-output; lm)
@ $I_F=70\text{mA}$, $T_A=25^\circ\text{C}$

Bin Code	Minimum	Maximum
A	0.6	1.2
B	1.0	1.8
C	1.5	2.4
D	2.0	3.0
E	2.5	3.6
F	3.0	4.2
G	3.5	4.8
H	4.0	6.1
J	5.0	7.3
L	6.0	9.7

Hue
(nm)
@ $I_F=70\text{mA}$, $T_A=25^\circ\text{C}$

Bin Code	Minimum	Maximum
H1	611	618
H2	614	622
H3	616	631

For LTL91xVHKSA

Forward Voltage
(Volt)
@ $I_F=70\text{mA}$, $T_A=25^\circ\text{C}$

Bin Code	Minimum	Maximum
Y	1.83	2.07
Z	1.95	2.19
0	2.07	2.31
1	2.19	2.43
2	2.31	2.55
3	2.43	2.67

**For LTL911VHKSA
LTL912VEKSA
LTL912VYKSA**

Hue
(nm)
@ $I_F=70\text{mA}$, $T_A=25^\circ\text{C}$

H28	615	623
H29	619	627
H30	623	631

For LTL912VEKSA

Hue
(nm)
@ $I_F=70\text{mA}$, $T_A=25^\circ\text{C}$

Bin Code	Minimum	Maximum
Y0	585	589
Y1	587	591
Y2	589	594
Y3	592	597
Y4	595	600
Y5	598	603

For LTL91xVYKSA

Packing Spec

1. Tube: 65pcs

Dim: 520mm x 9.6mm x 13.3mm

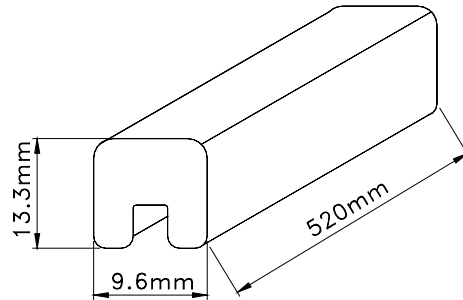

2. Inner carton: 153 tubes x 65 pcs = 9,945 pcs

Dim: 530mm x 175mm x 128mm

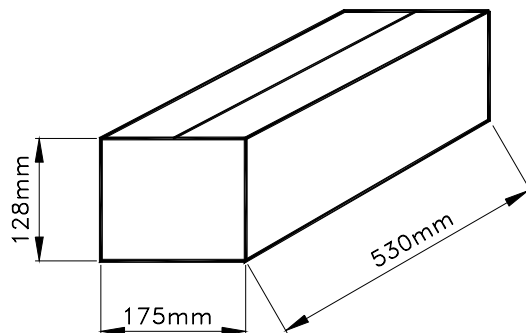

3. Outer carton: 4 inner cartons x 9,945 pcs = 39,780 pcs

Dim: 545mm x 370mm x 280mm

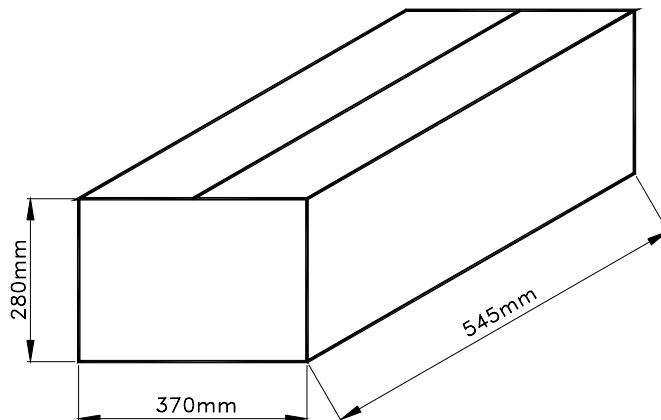

CAUTIONS**1. Application**

The LEDs described here are intended to be used for ordinary electronic equipment (such as office equipment, communication equipment and household applications). Consult Liteon's Sales in advance for information on applications in which exceptional reliability is required, particularly when the failure or malfunction of the LEDs may directly jeopardize life or health (such as in aviation, transportation, traffic control equipment, medical and life support systems and safety devices).

2. Storage

The storage ambient for the LEDs should not exceed 30°C temperature or 70% relative humidity.

It is recommended that LEDs out of their original packaging are used within three months.

For extended storage out of their original packaging, it is recommended that the LEDs be stored in a sealed container with appropriate desiccant or in desiccators with nitrogen ambient.

3. Cleaning

Use alcohol-based cleaning solvents such as isopropyl alcohol to clean the LEDs if necessary.

4. Lead Forming & Assembly

During lead forming, the leads should be bent at a point at least 3mm from the base of LED lens.

Do not use the base of the lead frame as a fulcrum during forming.

Lead forming must be done before soldering, at normal temperature.

During assembly on PCB, use minimum clinch force possible to avoid excessive mechanical stress.

5. Soldering

When soldering, leave a minimum of 2mm clearance from the base of the lens to the soldering point.

Dipping the lens into the solder must be avoided.

Do not apply any external stress to the lead frame during soldering while the LED is at high temperature.

Recommended soldering conditions :

Soldering iron		Wave soldering	
Temperature	300°C Max.	Pre-heat	100°C Max.
Soldering time	3 sec. Max. (one time only)	Pre-heat time	60 sec. Max.
		Solder wave	260°C Max.
		Soldering time	5 sec. Max.

Note: Excessive soldering temperature and/or time might result in deformation of the LED lens or catastrophic failure of the LED. IR re-flow is not suitable process for through whole type Piranha LED production.

The suggesting soldering conditions are listed in table which is on page 9. The wave solder temperature profile which is showed as below figure is taken on the bottom side of the PCB board. Both of the suggesting and maximum conditions are all shown in the figure as below.

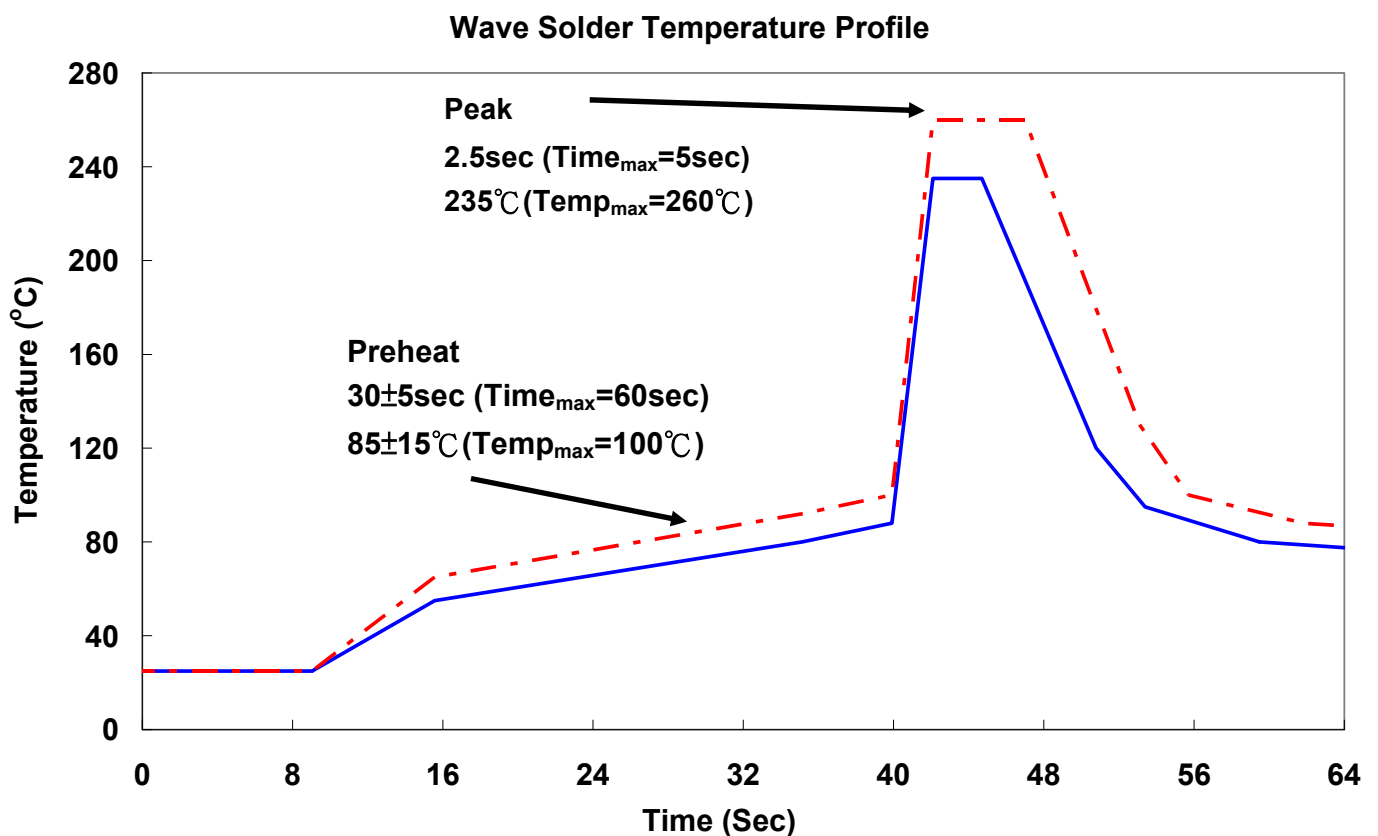

6. Drive Method

An LED is a current-operated device. In order to ensure intensity uniformity on multiple LEDs connected in parallel in an application, it is recommended that a current limiting resistor be incorporated in the drive circuit, in series with each LED as shown in Circuit A below.

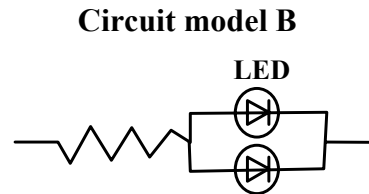
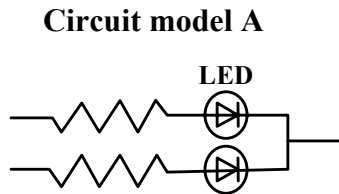

(A) Recommended circuit

(B) The brightness of each LED might appear different due to the differences in the I-V characteristics of those LEDs

7. ESD (Electrostatic Discharge)

Static Electricity or power surge will damage the LED.

Suggestions to prevent ESD damage:

- Use a conductive wrist band or anti- electrostatic glove when handling these LEDs
- All devices, equipment, and machinery must be properly grounded
- Work tables, storage racks, etc. should be properly grounded
- Use ion blower to neutralize the static charge which might have built up on surface of the LEDs plastic lens as a result of friction between LEDs during storage and handing

ESD-damaged LEDs will exhibit abnormal characteristics such as high reverse leakage current, low forward voltage, or “no light up” at low currents. To verify for ESD damage, check for “light up” and V_f of the suspect LEDs at low currents.

The V_f of “good” LEDs should be $>2.0V@0.1mA$ for InGaN product and $>1.4V@0.1mA$ for AlInGaP product.

Suggested checking list :

Training and Certification

1. Everyone working in a static-safe area is ESD-certified?
2. Training records kept and re-certification dates monitored?

Static-Safe Workstation & Work Areas

1. Static-safe workstation or work-areas have ESD signs?
2. All surfaces and objects at all static-safe workstation and within 1 ft measure less than 100V?
3. All ionizer activated, positioned towards the units?
4. Each work surface mats grounding is good?

Personnel Grounding

1. Every person (including visitors) handling ESD sensitive (ESDS) items wear wrist strap, heel strap or conductive shoes with conductive flooring?
2. If conductive footwear used, conductive flooring also present where operator stand or walk?
3. Garments, hairs or anything closer than 1 ft to ESD items measure less than 100V*?
4. Every wrist strap or heel strap/conductive shoes checked daily and result recorded for all DSL?
5. All wrist strap or heel strap checkers calibration up to date?

Note: *50V for Blue LED.

Device Handling

1. Every ESDS items identified by EIA-471 labels on item or packaging?
2. All ESDS items completely inside properly closed static-shielding containers when not at static-safe workstation?
3. No static charge generators (e.g. plastics) inside shielding containers with ESDS items?
4. All flexible conductive and dissipative package materials inspected before reuse or recycle?

Others

1. Audit result reported to entity ESD control coordinator?
2. Corrective action from previous audits completed?
3. Are audit records complete and on file?

8. Others

The appearance and specifications of the product may be modified for improvement, without prior notice. Liteon may make process or materials changes affecting the performance or other characteristics of our products. These products supplied after such changes will continue to meet published specifications, but may not be identical to products supplied as samples or under prior orders.



Компания «ЭлектроПласт» предлагает заключение долгосрочных отношений при поставках импортных электронных компонентов на взаимовыгодных условиях!

Наши преимущества:

- Оперативные поставки широкого спектра электронных компонентов отечественного и импортного производства напрямую от производителей и с крупнейших мировых складов;
- Поставка более 17-ти миллионов наименований электронных компонентов;
- Поставка сложных, дефицитных, либо снятых с производства позиций;
- Оперативные сроки поставки под заказ (от 5 рабочих дней);
- Экспресс доставка в любую точку России;
- Техническая поддержка проекта, помощь в подборе аналогов, поставка прототипов;
- Система менеджмента качества сертифицирована по Международному стандарту ISO 9001;
- Лицензия ФСБ на осуществление работ с использованием сведений, составляющих государственную тайну;
- Поставка специализированных компонентов (Xilinx, Altera, Analog Devices, Intersil, Interpoint, Microsemi, Aeroflex, Peregrine, Syfer, Eurofarad, Texas Instrument, Miteq, Cobham, E2V, MA-COM, Hittite, Mini-Circuits, General Dynamics и др.);

Помимо этого, одним из направлений компании «ЭлектроПласт» является направление «Источники питания». Мы предлагаем Вам помощь Конструкторского отдела:

- Подбор оптимального решения, техническое обоснование при выборе компонента;
- Подбор аналогов;
- Консультации по применению компонента;
- Поставка образцов и прототипов;
- Техническая поддержка проекта;
- Защита от снятия компонента с производства.



Как с нами связаться

Телефон: 8 (812) 309 58 32 (многоканальный)

Факс: 8 (812) 320-02-42

Электронная почта: org@eplast1.ru

Адрес: 198099, г. Санкт-Петербург, ул. Калинина, дом 2, корпус 4, литера А.