

98 42 937 0201



Pushing Performance

HARTING Han[®] GND



People | Power | Partnership

Han® GND - Mateable Potential Equalization

The new Han® GND series now enables pluggable grounding systems

Han® GND (Han® Ground) is the innovative HARTING solution for potential equalization. The new connector series makes it possible to execute grounding systems in a pluggable design for the first time.

The use of connectors has been well-established in the electrical cabling of machines and systems for many years. The advantage is quick and error-free commissioning. Potential equalization lines are still being permanently connected, which is relatively time-consuming and can be subject to errors. HARTING's remedy: the Han® GND. The single-pole connector in the robust IP 65 plastic housing is designed for stranded wires from 10 - 35 mm² and is optionally available in crimp or axial screw termination. The latter has the advantage that the lines can be connected without a special tool. A simple screwdriver is all it takes to achieve a quick and easy reliable connection. Extra connector mating security can be provided by the use of additional locking elements that prevent unintentional opening.

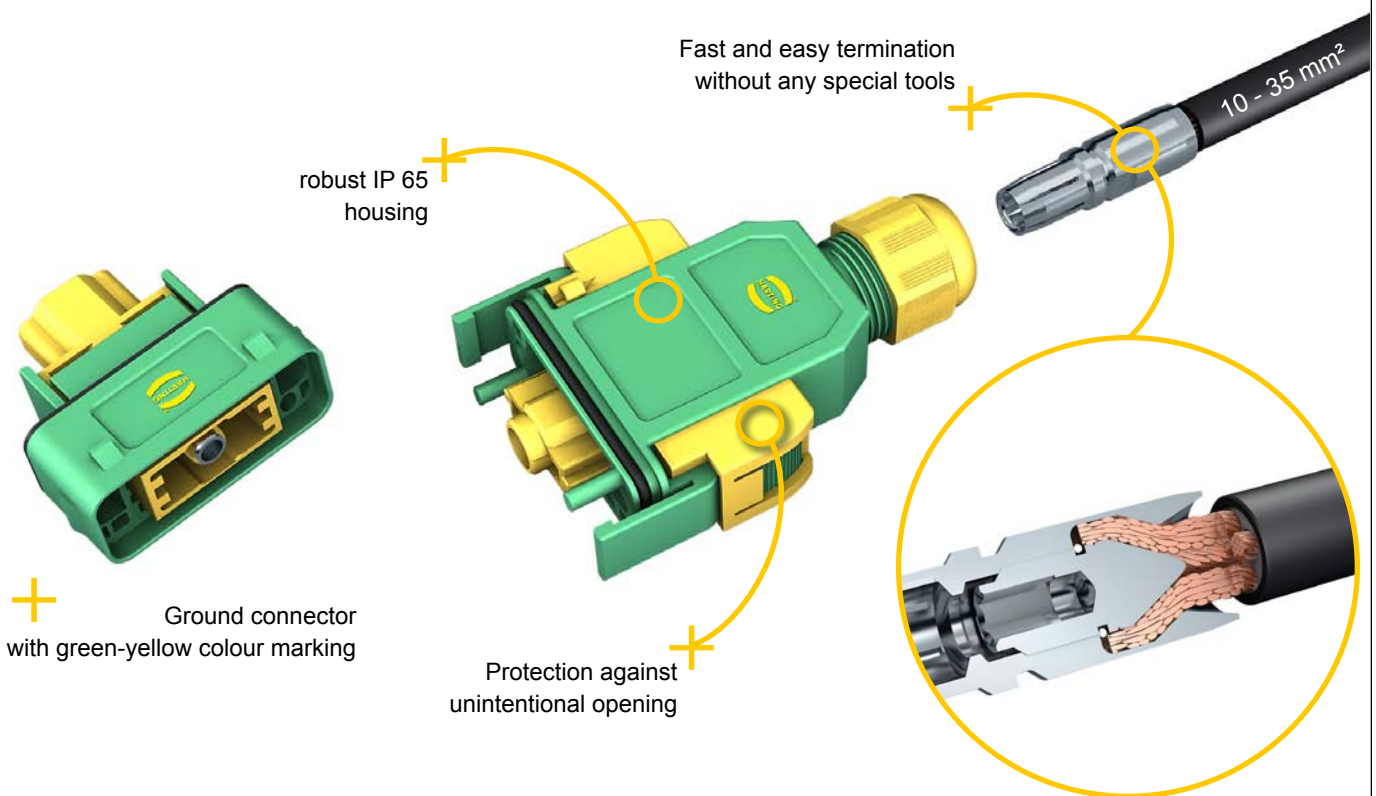

Features

- New: First connector for potential equalization
- Slim, space saving design
- Low cost plastic hoods and housings
- Colours: green and yellow
- Separate axial screw contacts can be terminated without any special tools directly to the wire.

Technical characteristics

Specifications	DIN EN 60 664-1 DIN EN 61 984
Hoods/Housings	
Material	polycarbonate
- hoods/housings	NBR
- seal	polyamide
- cable seal	
Limiting temperatures	-40 °C ... +85 °C
Flammability acc. to UL 94	V 0
Degree of protection according to DIN EN 60 529 for coupled connectors	IP 65
Mechanical working life	≥ 500 mating cycles
Cable diameter	7.5 - 14 mm
Modules	
Number of contacts	1
Material	polycarbonate
Limiting temperatures	-40 °C ... +125 °C
Flammability acc. to UL 94	V 0
Mechanical working life	≥ 500 mating cycles
Crimp Contacts	
Material	copper alloy
Surface	
- hard-silver plated	3 µm Ag
Contact resistance	≤ 0.3 mΩ
Crimp terminal	
- wire gauge ¹⁾	10 ... 35 mm ²
Axial Screw Contacts	
Material	copper alloy
Surface	
- hard-silver plated	3 µm Ag
Contact resistance	≤ 0.3 mΩ
Screw terminal	
- wire gauge ¹⁾	10 ... 35 mm ²
- AWG	6 ... 2
- hexagonal driver	SW 4
- tightening torque	

mm ²	10	16	25	35
Nm	6	6	7	8

1) geometric wire gauge

Number of contacts

1

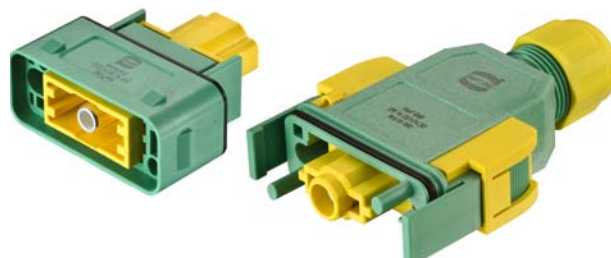

Mateable Potential Equalization

Identification Part-Number Drawings Dimensions in mm

Hood
top entry



09 14 001 0430

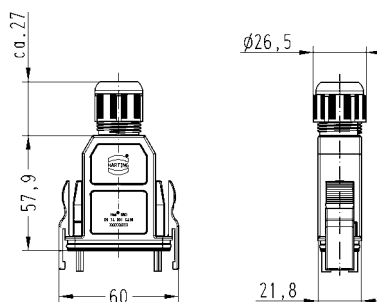

Unlocking Protection



09 14 000 9938

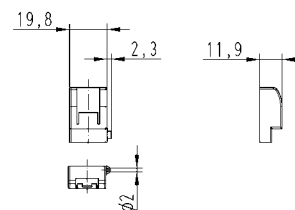

Housing



09 14 001 0330

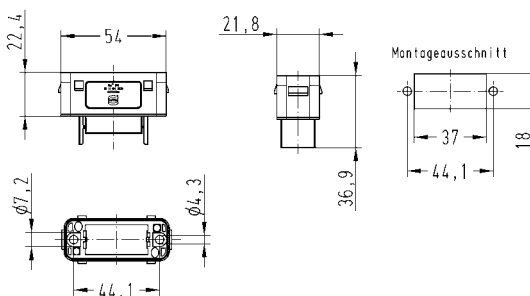

Hoods, cable to cable



09 14 001 0730

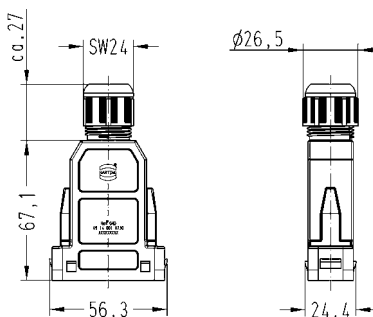





Gender changer / coupler
male / male

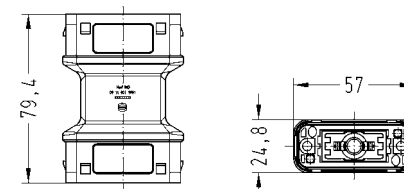

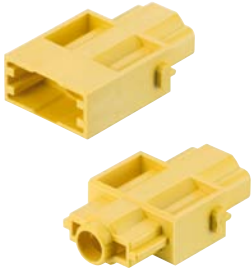
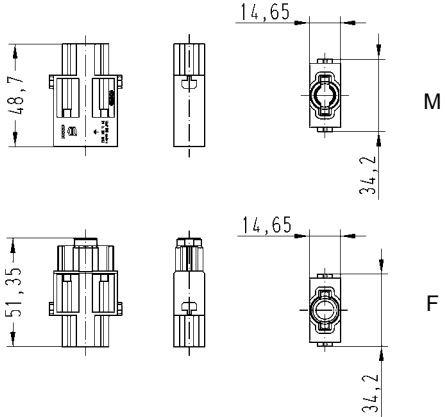

09 14 001 9901

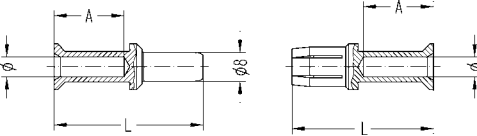

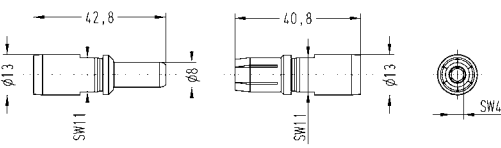
Identification	Part-Number		Drawings	Dimensions in mm
	Male module (M)	Female module (F)		
Modules order contacts separately 	09 14 001 3032	09 14 001 3132		M F

Identification	Wire gauge (mm ²)	Part number		Drawing	Dimensions in mm															
		Male contact	Female contact																	
Crimp contacts* 	10 16 25 35	09 11 000 6114 09 11 000 6116 09 11 000 6125 09 11 000 6135	09 11 000 6214 09 11 000 6216 09 11 000 6225 09 11 000 6235	 <table border="1" data-bbox="989 1198 1460 1366"> <thead> <tr> <th>Wire gauge</th> <th>Ø</th> <th>Stripping length (A)</th> </tr> </thead> <tbody> <tr> <td>10 mm²</td> <td>4.3</td> <td>19 mm</td> </tr> <tr> <td>16 mm²</td> <td>5.5</td> <td>19 mm</td> </tr> <tr> <td>25 mm²</td> <td>7.0</td> <td>19 mm</td> </tr> <tr> <td>35 mm²</td> <td>8.2</td> <td>16 mm</td> </tr> </tbody> </table> <p>for stranded wire acc. to IEC 60 228 Class 5</p>	Wire gauge	Ø	Stripping length (A)	10 mm ²	4.3	19 mm	16 mm ²	5.5	19 mm	25 mm ²	7.0	19 mm	35 mm ²	8.2	16 mm	
Wire gauge	Ø	Stripping length (A)																		
10 mm ²	4.3	19 mm																		
16 mm ²	5.5	19 mm																		
25 mm ²	7.0	19 mm																		
35 mm ²	8.2	16 mm																		
Axial screw contacts 	10-25 16-35	09 11 000 6112 09 11 000 6113	09 11 000 6212 09 11 000 6213	 <p>Stripping length 13 mm</p>																

Identification	Part number	Drawing	Dimensions in mm
Hex key SW 4 for axial setscrew with grip 	09 99 000 0363		
Bit 3/8" 	09 99 000 0370		

* Crimp zone acc. to DIN EN 46 235
 For further information see chapter 99 (Tools) in the main catalogue „Industrial Connectors Han®“

Assembly and construction

Assembly

Please use fine stranded wire (Class 5) which is recommend for the axial screw termination.

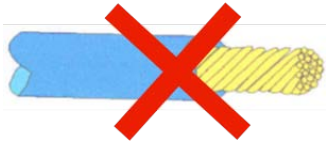

Do not twist the stripped wire!

1.

Please strip the wire. All suitable wire gauges have to be stripped with a length of 13 mm (acc. to Class 5 wire). Insert stripped wire into the terminal and push fully inside. Pay attention that all fine stranded wires are inserted in the contact.

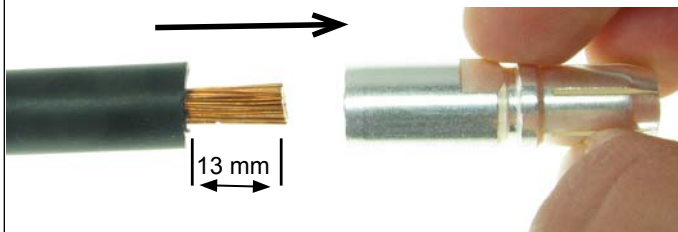

stripping length

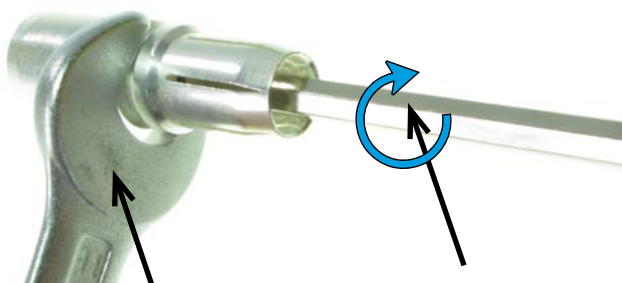
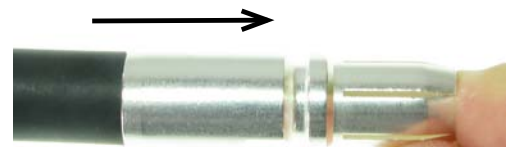

turn clockwise

Secure axial screw

2.

Please insert suitable torque key (SW 4) into the contact from mating side and turn the axial screw clockwise. For that purpose secure the axial screw with a spanner (SW 11). Tighten the screw to the specified torque value.

Assembly and construction



3. Insert the installed cable through the cable gland into the Han® GND housing! Push the axial screw contact into the module until you hear an audible click, which is the indicator that the contact snaps into position.



4. Push the module back into the housing and turn the cable gland clockwise.

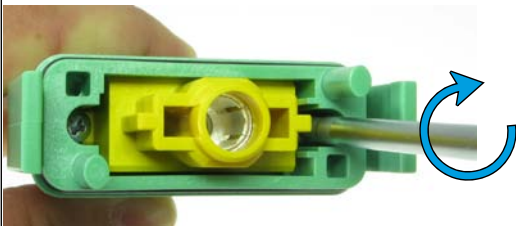

5. Mount the module in the housing with the enclosed screws.

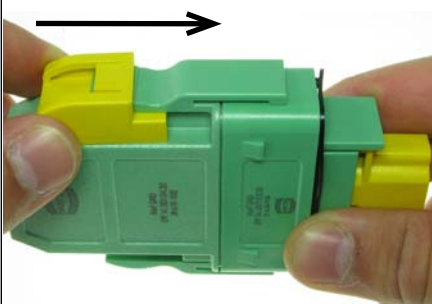

Protection against unintentional opening

1. Push the unlocking protection over the opening latches to prevent an unintentional opening (the connector can only be unma ted with a separate tool).

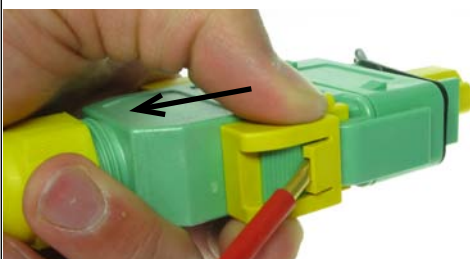

2. The removal of the unlocking protection can be done with a screwdriver for slotted screws (e.g. size 0.8 x 4.0). Insert the screwdriver in the unlocking protection slot and release the plastic latch until you are able to remove the unlocking protection with your fingers.



Pushing Performance

www.HARTING.com



Компания «ЭлектроПласт» предлагает заключение долгосрочных отношений при поставках импортных электронных компонентов на взаимовыгодных условиях!

Наши преимущества:

- Оперативные поставки широкого спектра электронных компонентов отечественного и импортного производства напрямую от производителей и с крупнейших мировых складов;
- Поставка более 17-ти миллионов наименований электронных компонентов;
- Поставка сложных, дефицитных, либо снятых с производства позиций;
- Оперативные сроки поставки под заказ (от 5 рабочих дней);
- Экспресс доставка в любую точку России;
- Техническая поддержка проекта, помощь в подборе аналогов, поставка прототипов;
- Система менеджмента качества сертифицирована по Международному стандарту ISO 9001;
- Лицензия ФСБ на осуществление работ с использованием сведений, составляющих государственную тайну;
- Поставка специализированных компонентов (Xilinx, Altera, Analog Devices, Intersil, Interpoint, Microsemi, Aeroflex, Peregrine, Syfer, Eurofarad, Texas Instrument, Miteq, Cobham, E2V, MA-COM, Hittite, Mini-Circuits, General Dynamics и др.);

Помимо этого, одним из направлений компании «ЭлектроПласт» является направление «Источники питания». Мы предлагаем Вам помощь Конструкторского отдела:

- Подбор оптимального решения, техническое обоснование при выборе компонента;
- Подбор аналогов;
- Консультации по применению компонента;
- Поставка образцов и прототипов;
- Техническая поддержка проекта;
- Защита от снятия компонента с производства.



Как с нами связаться

Телефон: 8 (812) 309 58 32 (многоканальный)

Факс: 8 (812) 320-02-42

Электронная почта: org@eplast1.ru

Адрес: 198099, г. Санкт-Петербург, ул. Калинина, дом 2, корпус 4, литера А.