

Precision Micropower Shunt Voltage Reference

■GENERAL DESCRIPTION

NJM2823 is a precision and low quiescent current shunt voltage reference.

Reference voltage form bandgap circuit has guaranteed the high accuracy of the $\pm 0.4\%$ with trimming. In addition the temperature drift of $15\text{ppm}/^\circ\text{C}$ typ. was actualized by the temperature compensating circuit. The reference voltage circuit operates by consumed low quiescent current of the $60\mu\text{A}$ for low power technology.

The Output capacitor is unnecessary by the phase compensating circuit which is built in. Tolerates capacitive loads, it is easy to use for application.

It is suitable for data converters, instrumentation, and other applications where precision reference is required.

■PACKAGE OUTLINE

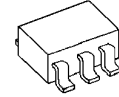

NJM2823F

■FEATURES

- Precision Reference Voltage $1136\text{mV}\pm 0.4\%$
- Low temperature coefficient $15\text{ppm}/^\circ\text{C}$ typ.
- Low Quiescent Current $60\mu\text{A}$ max.
- No Output Capacitor Required
- Tolerates Capacitive Loads
- Bipolar Technology
- Package Outline NJM2823F : SOT-23-5 (MTP5)

■PRODUCT VARIATION

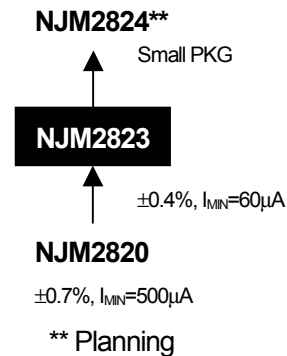

■BLOCK DIAGRAM

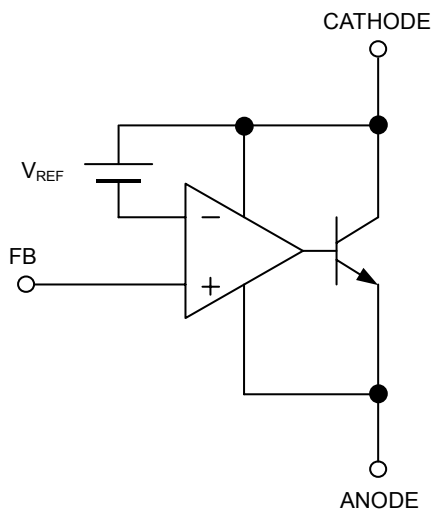

■PIN CONFIGURATION

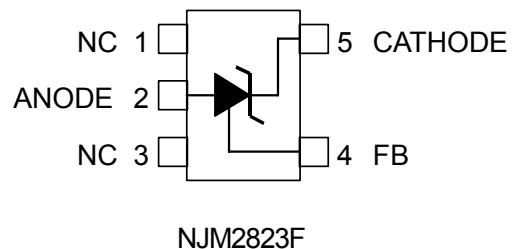

NJM2823

■ABSOLUTE MAXIMUM RATINGS (Ta=25°C)

PARAMETER	SYMBOL	MAXIMUM RATINGS	UNIT
Cathode Voltage	V_{KA}	14	V
Cathode Current	I_K	20	mA
Cathode-Anode Reverse Current	$-I_K$	10	mA
Power Dissipation	P_D	200	mW
Operating Temperature Range	T_{OPR}	-40 ~ +85	°C
Storage Temperature Range	T_{STG}	-40 ~ +125	°C

■RECOMMENDED OPERATING CONDITIONS (Ta=25°C)

PARAMETER	SYMBOL	MIN.	TYP.	MAX.	UNIT
Cathode Voltage	V_{KA}	V_{REF}	-	13	V
Cathode Current	I_K	0.06	-	12	mA

■ELECTRICAL CHARACTERISTICS ($I_K=100\mu A, T_a=25^\circ C$)

PARAMETER	SYMBOL	TEST CONDITION	MIN.	TYP.	MAX.	UNIT
Reference Voltage	V_{REF}	$V_{FB}=V_A$ (*)	1131.5	1136.0	1140.5	mV
Load Regulation	$\Delta V_{REF}/\Delta I_K$	$V_{FB}=V_A, I_{MIN} \leq I_K \leq 1mA$ (*)	-	0.15	1.1	mV
		$V_{FB}=V_A, 1mA \leq I_K \leq 12mA$ (*)	-	1.5	6	mV
Reference Voltage Change vs. Cathode Voltage Change	$\Delta V_{REF}/\Delta V_{KA}$	$ V_{REF} \leq V_{KA} \leq 13V,$ $R1=120k\Omega, R2=val$ (Note 1) (*)	-	-0.52	-2.8	mV/V
Minimum Operating Current	I_{MIN}	$V_{FB}=V_A$ (*)	-	20	60	μA
Feedback Current	I_{FB}	$R1=\infty, R2=120k\Omega$ (*)	-	100	200	nA
Dynamic Impedance	$ Z_{KA} $	$V_{FB}=V_A, f \leq 120Hz,$ $I_K=1mA, I_{AC}=0.1I_K$ (*)	-	0.1	-	Ω

■TEMPERATURE CHARACTERISTICS ($I_K=100\mu A, T_a=-40^\circ C \sim 85^\circ C$)

PARAMETER	SYMBOL	TEST CONDITION	MIN.	TYP.	MAX.	UNIT
Reference Voltage Change (Note 2)	ΔV_{REF_T}	$V_{FB}=V_A$ (*)	-	5.7 15	8.2 50	mV ppm/°C
Reference Input Current Change	ΔI_{FB_T}	$R1=\infty, R2=120k\Omega$ (*)	-	200	-	nA

Note 1: $|V_{REF}|$...Reference voltage includes error.

Note 2: Reference Voltage Change is defined as

$$\Delta V_{REF_T} [mV] = \pm <V_{REF} \times 0.4\%> \pm < \text{Reference Voltage Change [ppm/°C]} > \times <-40^\circ C \sim 25^\circ C> \times V_{REF}$$

The maximum value of "Reference Voltage Change" is determined based on sampling evaluation from the 5 initial production lots, and thus not tested in the production test. Therefore, these values are for the reference design purpose only.

(*1): Test Circuit (Fig.1)

(*2): Test Circuit (Fig.2)

TEST CIRCUIT

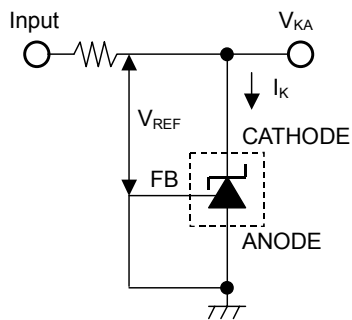

Fig.1 $V_{KA}=V_{REF}$ to test circuit

$$V_{FB}=V_A$$

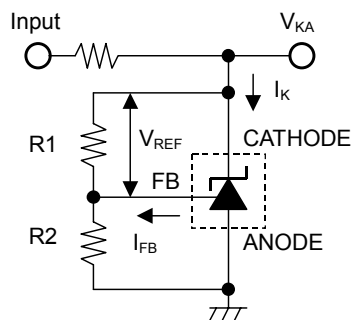
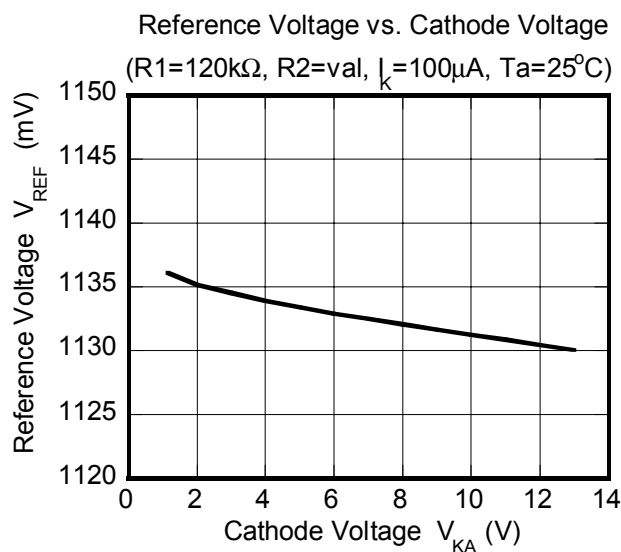
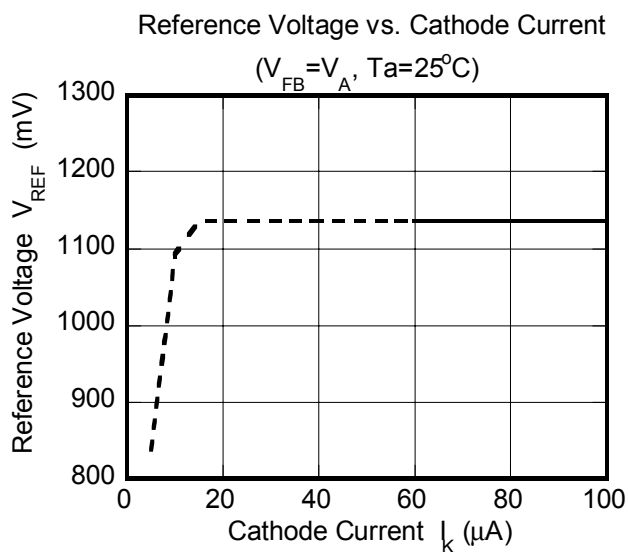
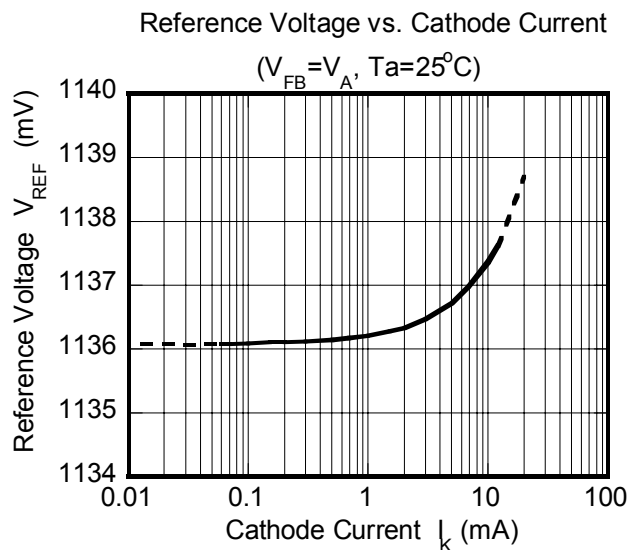
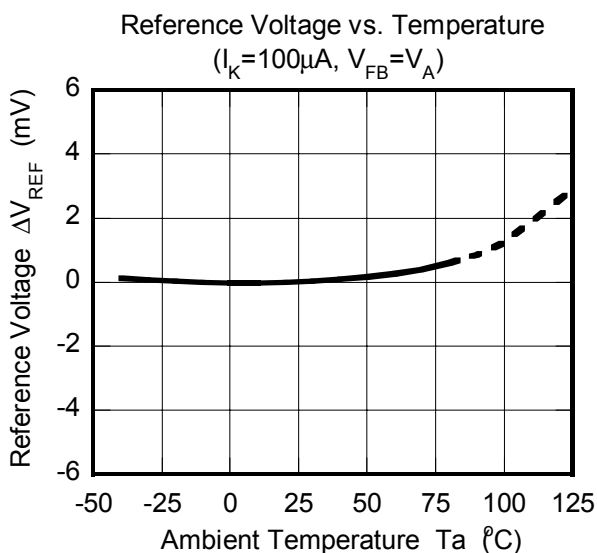

Fig.2 $V_{KA}>V_{REF}$ to test circuit

$$V_{KA} = V_{REF} \left(1 + \frac{R2}{R1} \right) + I_{FB} \times R2$$

TYPICAL CHARACTERISTICS



■ TYPICAL CHARACTERISTICS

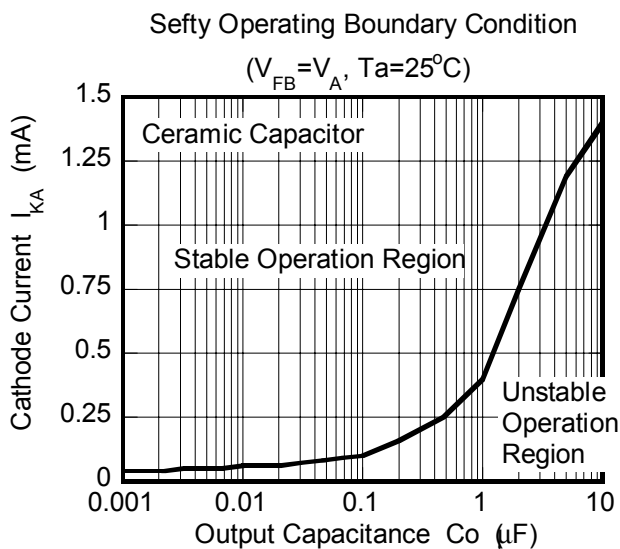
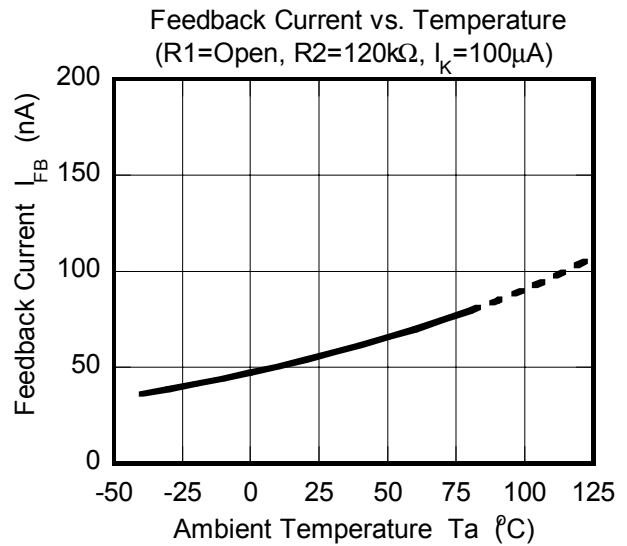
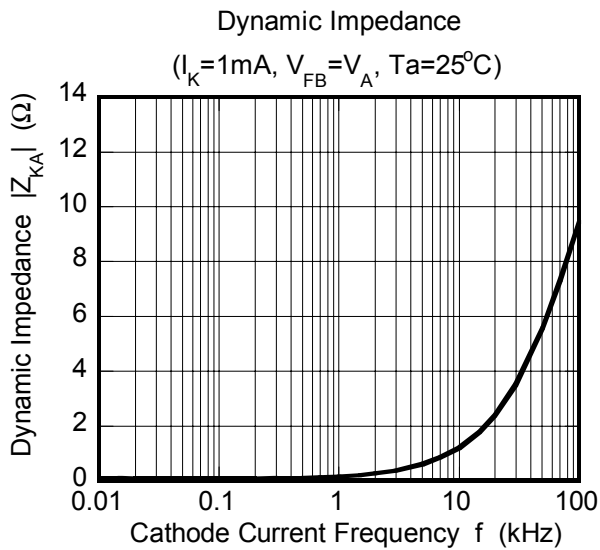

Note) Oscillation might occur while operating within the range of safety curve.
So that, it is necessary to make ample margins by taking considerations of fluctuation of the device.

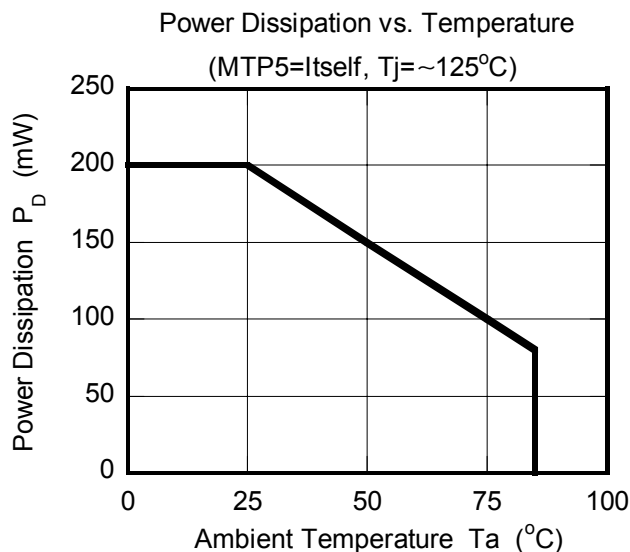

■Application Information

The NJM2823 creates a highly accurate reference voltage, enabling a low power consumption application circuit to be configured.

In the basic application (Fig.1) of the shunt regulator, a voltage drop is created by resistor R_S connected between the input voltage and the NJM2823, and the output voltage (cathode – anode voltage = V_{KA}) is controlled to a constant value. The voltage drop due to R_S is determined by the total of the output current and the cathode current. The feedback to the output voltage is controlled by the FB terminal, and the cathode current changes so that the set voltage is obtained.

As a result, R_S must conform to the following conditions.

*Minimum cathode current = 60 μ A min

Conditions under which the input voltage is a minimum and the output current is a maximum.

*Maximum cathode current = 12 mA max

Conditions under which the input voltage is a maximum and the output current is a minimum.

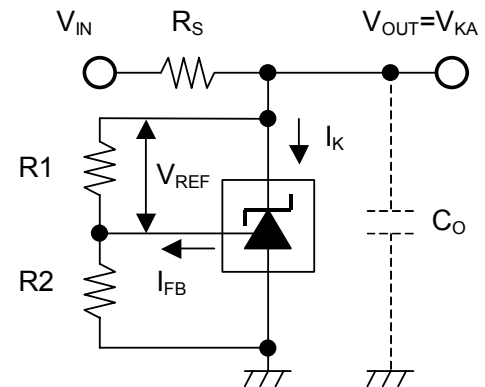

Fig.1 basic application

The value of resistor R_S is obtained by means of the following formula.

$$R_S = \frac{V_{IN} - V_{OUT}}{I_k + I_{OUT}} \quad [\Omega]$$

The output voltage can be set using any desired value between V_{REF} and 13 V.

The output voltage is set according to the ratio between the values of the two external resistors, however an error occurs depending upon the feedback current. The error can be minimized by combining two external resistors with low resistance values. The formula for calculating the output voltage setting is shown below.

$$V_{OUT} = \left(\frac{R_2}{R_1} + 1 \right) \times V_{REF} + I_{FB} \times R_2$$

As shown in the “reference voltage versus cathode voltage” characteristics example, the reference voltage value has negative characteristics. The reference voltage is corrected by using $\Delta V_{REF}/\Delta V_{KA}$ stipulated by the electrical characteristics.

$$\Delta V_{REF} = \left(\frac{\Delta V_{REF}}{\Delta V_{KA}} \right) \times V_{OUT}$$

V_{KA} (V)	R_1 (k Ω)	R_2 (k Ω)
1.20	Open	Short
1.50	120	38.2
1.80	120	69.5
2.50	120	142.8
3.30	120	226.4
5.00	120	404.3

Table.1 Examples of output voltage settings at the standard

Table 1 shows an example of combining constants in the case where R_1 is assumed to be 120 k Ω .

The error in the output voltage also varies with the accuracy of the resistors. In order to realize a highly accurate application, the relative accuracy can be improved by either using accurate resistors or combining integrated resistors.

The NJM2823 contains an optimized phase compensation circuit. Consequently, in the basic application a stable reference voltage is generated without the use of an output capacitor. As is indicated in the “dynamic impedance versus frequency” characteristics, the impedance increases in proportion to the frequency. If necessary, connect an output capacitor to reduce the high frequency impedance. You can connect a ceramic capacitor to obtain high stability, but in this case be sure to use the NJM2823 in the stable operation region while referring to the “stable operation boundary conditions” characteristics example.

MEMO

[CAUTION]

The specifications on this databook are only given for information, without any guarantee as regards either mistakes or omissions. The application circuits in this databook are described only to show representative usages of the product and not intended for the guarantee or permission of any right including the industrial rights.

Mouser Electronics

Authorized Distributor

Click to View Pricing, Inventory, Delivery & Lifecycle Information:

[NJR:](#)

[NJM2823F-TE2](#) [NJM2823F-TE1](#)



Компания «ЭлектроПласт» предлагает заключение долгосрочных отношений при поставках импортных электронных компонентов на взаимовыгодных условиях!

Наши преимущества:

- Оперативные поставки широкого спектра электронных компонентов отечественного и импортного производства напрямую от производителей и с крупнейших мировых складов;
- Поставка более 17-ти миллионов наименований электронных компонентов;
- Поставка сложных, дефицитных, либо снятых с производства позиций;
- Оперативные сроки поставки под заказ (от 5 рабочих дней);
- Экспресс доставка в любую точку России;
- Техническая поддержка проекта, помощь в подборе аналогов, поставка прототипов;
- Система менеджмента качества сертифицирована по Международному стандарту ISO 9001;
- Лицензия ФСБ на осуществление работ с использованием сведений, составляющих государственную тайну;
- Поставка специализированных компонентов (Xilinx, Altera, Analog Devices, Intersil, Interpoint, Microsemi, Aeroflex, Peregrine, Syfer, Eurofarad, Texas Instrument, Miteq, Cobham, E2V, MA-COM, Hittite, Mini-Circuits, General Dynamics и др.);

Помимо этого, одним из направлений компании «ЭлектроПласт» является направление «Источники питания». Мы предлагаем Вам помощь Конструкторского отдела:

- Подбор оптимального решения, техническое обоснование при выборе компонента;
- Подбор аналогов;
- Консультации по применению компонента;
- Поставка образцов и прототипов;
- Техническая поддержка проекта;
- Защита от снятия компонента с производства.



Как с нами связаться

Телефон: 8 (812) 309 58 32 (многоканальный)

Факс: 8 (812) 320-02-42

Электронная почта: org@eplast1.ru

Адрес: 198099, г. Санкт-Петербург, ул. Калинина, дом 2, корпус 4, литера А.