

# MAX5713/MAX5714/MAX5715

## Ultra-Small, Quad-Channel, 8-/10-/12-Bit Buffered Output DACs with Internal Reference and SPI Interface

### General Description

The MAX5713/MAX5714/MAX5715 4-channel, low-power, 8-/10-/12-bit, voltage-output digital-to-analog converters (DACs) include output buffers and an internal reference that is selectable to be 2.048V, 2.500V, or 4.096V. The MAX5713/MAX5714/MAX5715 accept a wide supply voltage range of 2.7V to 5.5V with extremely low power (3mW) consumption to accommodate most low-voltage applications. A precision external reference input allows rail-to-rail operation and presents a 100k $\Omega$  (typ) load to an external reference.

The MAX5713/MAX5714/MAX5715 have a 50MHz 3-wire SPI/QSPI™/MICROWIRE®/DSP-compatible serial interface that also includes a RDY output for daisy-chain applications. The DAC output is buffered and has a low supply current of less than 250 $\mu$ A per channel and a low offset error of  $\pm 0.5$ mV (typ). On power-up, the MAX5713/MAX5714/MAX5715 reset the DAC outputs to zero, providing additional safety for applications that drive valves or other transducers which need to be off on power-up. The internal reference is initially powered down to allow use of an external reference. The MAX5713/MAX5714/MAX5715 allow simultaneous output updates using software LOAD commands or the hardware load DAC logic input (LDAC).

A clear logic input ( $\overline{\text{CLR}}$ ) allows the contents of the CODE and the DAC registers to be cleared asynchronously and sets the DAC outputs to zero. The MAX5713/MAX5714/MAX5715 are available in a 14-pin TSSOP and an ultra-small, 12-bump WLP package and are specified over the -40°C to +125°C temperature range.

### Applications

- Programmable Voltage and Current Sources
- Gain and Offset Adjustment
- Automatic Tuning and Optical Control
- Power Amplifier Control and Biasing
- Process Control and Servo Loops
- Portable Instrumentation
- Data Acquisition

QSPI is a trademark of Motorola, Inc.

MICROWIRE is a registered trademark of National Semiconductor Corporation.

$\mu$ MAX is a registered trademark of Maxim Integrated Products, Inc.

**For pricing, delivery, and ordering information, please contact Maxim Direct at 1-888-629-4642, or visit Maxim's website at [www.maximintegrated.com](http://www.maximintegrated.com).**

### Benefits and Features

- ◆ **Four High-Accuracy DAC Channels**
  - ◇ 12-Bit Accuracy Without Adjustment
  - ◇  $\pm 1$  LSB INL Buffered Voltage Output
  - ◇ Monotonic Over All Operating Conditions
  - ◇ Independent Mode Settings for Each DAC
- ◆ **Three Precision Selectable Internal References**
  - ◇ 2.048V, 2.500V, or 4.096V
- ◆ **Internal Output Buffer**
  - ◇ Rail-to-Rail Operation with External Reference
  - ◇ 4.5 $\mu$ s Settling Time
  - ◇ Outputs Directly Drive 2k $\Omega$  Loads
- ◆ **Small 5mm x 4.4mm 14-Pin TSSOP or Ultra-Small 1.6mm x 2.2mm 12-Bump WLP Package**
- ◆ **Wide 2.7V to 5.5V Supply Range**
- ◆ **Separate 1.8V to 5.5V V<sub>DDIO</sub> Power-Supply Input**
- ◆ **50MHz 3-Wire SPI/QSPI/MICROWIRE/DSP Compatible Serial Interface with  $\overline{\text{RDY}}$  Output**
- ◆ **Power-On-Reset to Zero-Scale DAC Output**
- ◆  **$\overline{\text{LDAC}}$  and  $\overline{\text{CLR}}$  For Asynchronous Control**
- ◆ **Three Software-Selectable Power-Down Output Impedances**
  - ◇ 1k $\Omega$ , 100k $\Omega$ , or High Impedance

### Functional Diagram

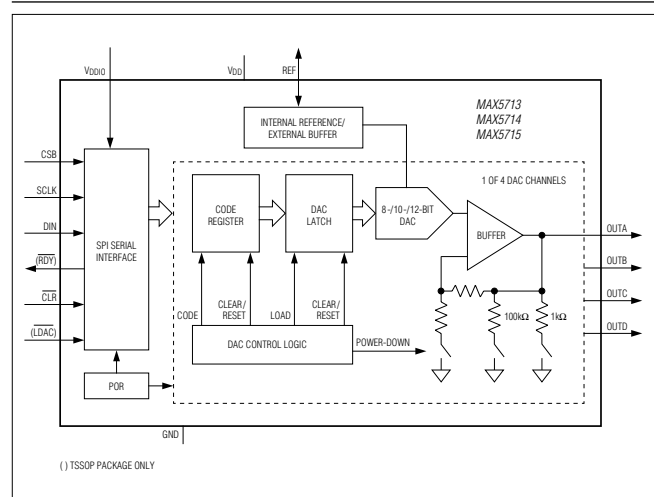

**Ordering Information** appears at end of data sheet.

For related parts and recommended products to use with this part, refer to: [www.maximintegrated.com/MAX5713.related](http://www.maximintegrated.com/MAX5713.related)

# MAX5713/MAX5714/MAX5715

## Ultra-Small, Quad-Channel, 8-/10-/12-Bit Buffered Output DACs with Internal Reference and SPI Interface

### ABSOLUTE MAXIMUM RATINGS

$V_{DD}$ , $V_{DDIO}$ to GND .....	-0.3V to +6V	Maximum Continuous Current into Any Pin .....	±50mA
$OUT_{-}$ , REF to GND .....	-0.3V to the lower of ( $V_{DD} + 0.3V$ ) and +6V	Operating Temperature Range .....	-40°C to +125°C
$CSB$ , $SCLK$ , $\overline{LDAC}$ , $\overline{CLR}$ to GND .....	-0.3V to +6V	Storage Temperature Range .....	-65°C to +150°C
$DIN$ , $\overline{RDY}$ to GND .....	-0.3V to the lower of ( $V_{DDIO} + 0.3V$ ) and +6V	Lead Temperature (TSSOP only)(soldering, 10s) .....	+300°C
Continuous Power Dissipation ( $T_A = +70^{\circ}C$ )		Soldering Temperature (reflow) .....	+260°C
TSSOP (derate at 10mW/°C above 70°C) .....	797mW		
WLP (derate at 16.1mW/°C above 70°C) .....	1288mW		

Stresses beyond those listed under "Absolute Maximum Ratings" may cause permanent damage to the device. These are stress ratings only, and functional operation of the device at these or any other conditions beyond those indicated in the operational sections of the specifications is not implied. Exposure to absolute maximum rating conditions for extended periods may affect device reliability.

### PACKAGE THERMAL CHARACTERISTICS (Note 1)

TSSOP		WLP	
Junction-to-Ambient Thermal Resistance ( $\theta_{JA}$ ) .....	100°C/W	Junction-to-Ambient Thermal Resistance ( $\theta_{JA}$ )	
Junction-to-Case Thermal Resistance ( $\theta_{JC}$ ) .....	30°C/W	(Note 2) .....	62°C/W

**Note 1:** Package thermal resistances were obtained using the method described in JEDEC specification JESD51-7, using a four-layer board. For detailed information on package thermal considerations, refer to [www.maximintegrated.com/thermal-tutorial](http://www.maximintegrated.com/thermal-tutorial).

**Note 2:** Visit [www.maximintegrated.com/app-notes/index.mvp/id/1891](http://www.maximintegrated.com/app-notes/index.mvp/id/1891) for information about the thermal performance of WLP packaging.

### ELECTRICAL CHARACTERISTICS

( $V_{DD} = 2.7V$  to 5.5V,  $V_{DDIO} = 1.8V$  to 5.5V,  $V_{GND} = 0V$ ,  $C_L = 200pF$ ,  $R_L = 2k\Omega$ ,  $T_A = -40^{\circ}C$  to +125°C, unless otherwise noted. Typical values are at  $T_A = +25^{\circ}C$ .) (Note 3)

PARAMETER	SYMBOL	CONDITIONS	MIN	TYP	MAX	UNITS
<b>DC PERFORMANCE (Note 4)</b>						
Resolution and Monotonicity	N	MAX5713	8			Bits
		MAX5714	10			
		MAX5715	12			
Integral Nonlinearity (Note 5)	INL	MAX5713	-0.25	±0.05	+0.25	LSB
		MAX5714	-0.5	±0.25	+0.5	
		MAX5715	-1	±0.5	+1	
Differential Nonlinearity (Note 5)	DNL	MAX5713	-0.25	±0.05	+0.25	LSB
		MAX5714	-0.5	±0.1	+0.5	
		MAX5715	-1	±0.2	+1	
Offset Error (Note 6)	OE		-5	±0.5	+5	mV
Offset Error Drift				±10		µV/°C
Gain Error (Note 6)	GE		-1.0	±0.1	+1.0	%FS
Gain Temperature Coefficient		With respect to $V_{REF}$		±3.0		ppm of FS/°C
Zero-Scale Error			0		10	mV
Full-Scale Error		With respect to $V_{REF}$	-0.5		+0.5	%FS

# MAX5713/MAX5714/MAX5715

## Ultra-Small, Quad-Channel, 8-/10-/12-Bit Buffered Output DACs with Internal Reference and SPI Interface

### ELECTRICAL CHARACTERISTICS (continued)

( $V_{DD} = 2.7V$  to  $5.5V$ ,  $V_{DDIO} = 1.8V$  to  $5.5V$ ,  $V_{GND} = 0V$ ,  $C_L = 200pF$ ,  $R_L = 2k\Omega$ ,  $T_A = -40^\circ C$  to  $+125^\circ C$ , unless otherwise noted. Typical values are at  $T_A = +25^\circ C$ .) (Note 3)

PARAMETER	SYMBOL	CONDITIONS		MIN	TYP	MAX	UNITS
<b>DAC OUTPUT CHARACTERISTICS</b>							
Output Voltage Range (Note 7)		No load		0		$V_{DD}$	V
		2k $\Omega$ load to GND		0		$V_{DD} - 0.2$	
		2k $\Omega$ load to $V_{DD}$		0.2		$V_{DD}$	
Load Regulation		$V_{OUT} = V_{FS}/2$	$V_{DD} = 3V \pm 10\%$ , $ I_{OUT}  \leq 5mA$		300		$\mu V/mA$
			$V_{DD} = 5V \pm 10\%$ , $ I_{OUT}  \leq 10mA$		300		
DC Output Impedance		$V_{OUT} = V_{FS}/2$	$V_{DD} = 3V \pm 10\%$ , $ I_{OUT}  \leq 5mA$		0.3		$\Omega$
			$V_{DD} = 5V \pm 10\%$ , $ I_{OUT}  \leq 10mA$		0.3		
Maximum Capacitive Load Handling	$C_L$				500		pF
Resistive Load Handling	$R_L$			2			k $\Omega$
Short-Circuit Output Current		$V_{DD} = 5.5V$	Sourcing (output shorted to GND)		30		mA
			Sinking (output shorted to $V_{DD}$ )		50		
DC Power-Supply Rejection		$V_{DD} = 3V \pm 10\%$ or $5V \pm 10\%$			100		$\mu V/V$
<b>DYNAMIC PERFORMANCE</b>							
Voltage-Output Slew Rate	SR	Positive and negative			1.0		V/ $\mu s$
Voltage-Output Settling Time		$1/4$ scale to $3/4$ scale, to $\leq 1$ LSB, MAX5713			2.2		$\mu s$
		$1/4$ scale to $3/4$ scale, to $\leq 1$ LSB, MAX5714			2.6		
		$1/4$ scale to $3/4$ scale, to $\leq 1$ LSB, MAX5715			4.5		
DAC Glitch Impulse		Major code transition			7		nV*s
Channel-to-Channel Feedthrough (Note 8)		External reference			3.5		nV*s
		Internal reference			3.3		
Digital Feedthrough		Code = 0, all digital inputs from 0V to $V_{DDIO}$			0.2		nV*s
Power-Up Time		Startup calibration time (Note 9)			200		$\mu s$
		From power-down			50		$\mu s$

# MAX5713/MAX5714/MAX5715

## Ultra-Small, Quad-Channel, 8-/10-/12-Bit Buffered Output DACs with Internal Reference and SPI Interface

### ELECTRICAL CHARACTERISTICS (continued)

( $V_{DD} = 2.7V$  to  $5.5V$ ,  $V_{DDIO} = 1.8V$  to  $5.5V$ ,  $V_{GND} = 0V$ ,  $C_L = 200pF$ ,  $R_L = 2k\Omega$ ,  $T_A = -40^\circ C$  to  $+125^\circ C$ , unless otherwise noted. Typical values are at  $T_A = +25^\circ C$ .) (Note 3)

PARAMETER	SYMBOL	CONDITIONS		MIN	TYP	MAX	UNITS
Output Voltage-Noise Density (DAC Output at Midscale)		External reference	f = 1kHz		90		nV/ $\sqrt{Hz}$
			f = 10kHz		82		
		2.048V internal reference	f = 1kHz		112		
			f = 10kHz		102		
		2.5V internal reference	f = 1kHz		125		
			f = 10kHz		110		
		4.096V internal reference	f = 1kHz		160		
			f = 10kHz		145		
Integrated Output Noise (DAC Output at Midscale)		External reference	f = 0.1Hz to 10Hz		12		$\mu V_{P-P}$
			f = 0.1Hz to 10kHz		76		
			f = 0.1Hz to 300kHz		385		
		2.048V internal reference	f = 0.1Hz to 10Hz		14		
			f = 0.1Hz to 10kHz		91		
			f = 0.1Hz to 300kHz		450		
		2.5V internal reference	f = 0.1Hz to 10Hz		15		
			f = 0.1Hz to 10kHz		99		
			f = 0.1Hz to 300kHz		470		
		4.096V internal reference	f = 0.1Hz to 10Hz		16		
			f = 0.1Hz to 10kHz		124		
			f = 0.1Hz to 300kHz		490		
Output Voltage-Noise Density (DAC Output at Full Scale)		External reference	f = 1kHz		114		nV/ $\sqrt{Hz}$
			f = 10kHz		99		
		2.048V internal reference	f = 1kHz		175		
			f = 10kHz		153		
		2.5V internal reference	f = 1kHz		200		
			f = 10kHz		174		
		4.096V internal reference	f = 1kHz		295		
			f = 10kHz		255		
Integrated Output Noise (DAC Output at Full Scale)		External reference	f = 0.1Hz to 10Hz		13		$\mu V_{P-P}$
			f = 0.1Hz to 10kHz		94		
			f = 0.1Hz to 300kHz		540		
		2.048V internal reference	f = 0.1Hz to 10Hz		19		
			f = 0.1Hz to 10kHz		143		
			f = 0.1Hz to 300kHz		685		
		2.5V internal reference	f = 0.1Hz to 10Hz		21		
			f = 0.1Hz to 10kHz		159		
			f = 0.1Hz to 300kHz		705		
		4.096V internal reference	f = 0.1Hz to 10Hz		26		
			f = 0.1Hz to 10kHz		213		
			f = 0.1Hz to 300kHz		750		

# MAX5713/MAX5714/MAX5715

## Ultra-Small, Quad-Channel, 8-/10-/12-Bit Buffered Output DACs with Internal Reference and SPI Interface

### ELECTRICAL CHARACTERISTICS (continued)

( $V_{DD} = 2.7V$  to  $5.5V$ ,  $V_{DDIO} = 1.8V$  to  $5.5V$ ,  $V_{GND} = 0V$ ,  $C_L = 200pF$ ,  $R_L = 2k\Omega$ ,  $T_A = -40^\circ C$  to  $+125^\circ C$ , unless otherwise noted. Typical values are at  $T_A = +25^\circ C$ .) (Note 3)

PARAMETER	SYMBOL	CONDITIONS	MIN	TYP	MAX	UNITS	
<b>REFERENCE INPUT</b>							
Reference Input Range	$V_{REF}$		1.24		$V_{DD}$	V	
Reference Input Current	$I_{REF}$	$V_{REF} = V_{DD} = 5.5V$		55	74	$\mu A$	
Reference Input Impedance	$R_{REF}$		75	100		$k\Omega$	
<b>REFERENCE OUTPUT</b>							
Reference Output Voltage	$V_{REF}$	$V_{REF} = 2.048V$ , $T_A = +25^\circ C$	2.043	2.048	2.053	V	
		$V_{REF} = 2.5V$ , $T_A = +25^\circ C$	2.494	2.500	2.506		
		$V_{REF} = 4.096V$ , $T_A = +25^\circ C$	4.086	4.096	4.106		
Reference Temperature Coefficient (Note 10)		MAX5715A		$\pm 3.7$	$\pm 10$	ppm/ $^\circ C$	
		MAX5713/MAX5714/MAX5715B		$\pm 10$	$\pm 25$		
Reference Drive Capacity		External load		25		$k\Omega$	
Reference Capacitive Load				200		pF	
Reference Load Regulation		$I_{SOURCE} = 0$ to $500\mu A$		2		mV/mA	
Reference Line Regulation				0.05		mV/V	
<b>POWER REQUIREMENTS</b>							
Supply Voltage	$V_{DD}$	$V_{REF} = 4.096V$	4.5		5.5	V	
		All other options	2.7		5.5		
I/O Supply Voltage	$V_{DDIO}$		1.8		5.5	V	
Supply Current (Note 11)	$I_{DD}$	Internal reference	$V_{REF} = 2.048V$		0.93	1.25	mA
			$V_{REF} = 2.5V$		0.98	1.30	
			$V_{REF} = 4.096V$		1.16	1.50	
		External reference	$V_{REF} = 3V$		0.85	1.15	
			$V_{REF} = 5V$		1.10	1.40	
Interface Supply Current (Note 11)	$I_{DDIO}$				1	$\mu A$	
Power-Down Mode Supply Current	$I_{PD}$	All DACs off, internal reference ON		140		$\mu A$	
		All DACs off, internal reference OFF, $T_A = -40^\circ C$ to $+85^\circ C$		0.5	1		
		All DACs off, internal reference OFF, $T_A = +125^\circ C$		1.2	2.5		
<b>DIGITAL INPUT CHARACTERISTICS (CSB, SCLK, DIN, LDAC, CLR)</b>							
Hysteresis Voltage	$V_H$			0.15		V	
Input High Voltage	$V_{IH}$	$2.2V < V_{DDIO} < 5.5V$		$0.7 \times V_{DDIO}$		V	
		$1.8V < V_{DDIO} < 2.2V$		$0.8 \times V_{DDIO}$			

# MAX5713/MAX5714/MAX5715

## Ultra-Small, Quad-Channel, 8-/10-/12-Bit Buffered Output DACs with Internal Reference and SPI Interface

### ELECTRICAL CHARACTERISTICS (continued)

( $V_{DD} = 2.7V$  to  $5.5V$ ,  $V_{DDIO} = 1.8V$  to  $5.5V$ ,  $V_{GND} = 0V$ ,  $C_L = 200pF$ ,  $R_L = 2k\Omega$ ,  $T_A = -40^\circ C$  to  $+125^\circ C$ , unless otherwise noted. Typical values are at  $T_A = +25^\circ C$ .) (Note 3)

PARAMETER	SYMBOL	CONDITIONS	MIN	TYP	MAX	UNITS
Input Low Voltage (Note 11)	$V_{IL}$	$2.2V < V_{DDIO} < 5.5V$			$0.3 \times V_{DDIO}$	V
		$1.8V < V_{DDIO} < 2.2V$			$0.2 \times V_{DDIO}$	
Input Leakage Current	$I_{IN}$	$V_{IN} = 0V$ or $V_{DDIO}$ (Note 11)		$\pm 0.1$	$\pm 1$	$\mu A$
Input Capacitance (Note 10)	$C_{IN}$				10	pF
<b>DIGITAL OUTPUT (<math>\overline{RDY}</math>)</b>						
Output High Voltage	$V_{OH}$	$V_{DDIO} > 2.5V$ , $I_{SOURCE} = 3mA$			$V_{DDIO} - 0.2$	V
		$V_{DDIO} > 1.8V$ , $I_{SOURCE} = 2mA$			$V_{DDIO} - 0.2$	V
Output Low Voltage	$V_{OL}$	$V_{DDIO} > 2.5V$ , $I_{SINK} = 3mA$			0.2	V
		$V_{DDIO} > 1.8V$ , $I_{SINK} = 2mA$			0.2	V
Output Short-Circuit Current	$I_{OSS}$	$I_{SINK}$ , $I_{SOURCE}$		$\pm 100$		mA
<b>SPI TIMING CHARACTERISTICS (CSB, SCLK, DIN, <math>\overline{RDY}</math>)</b>						
SCLK Frequency	$f_{SCLK}$	$2.7V < V_{DDIO} < 5.5V$ , standalone, daisy chain (Note 12)	0		50	MHz
			0		20	
		$1.8V < V_{DDIO} < 2.7V$ , standalone, daisy chain (Note 12)	0		33	
			0		20	
SCLK Period	$t_{SCLK}$	$2.7V < V_{DDIO} < 5.5V$	20			ns
		$1.8V < V_{DDIO} < 2.7V$	30			
SCLK Pulse Width High	$t_{CH}$		8			ns
SCLK Pulse Width Low	$t_{CL}$		8			ns
CSB Fall to SCLK Fall Setup Time	$t_{CSS0}$	To first SCLK falling edge	8			ns
CSB Fall to SCLK Fall Hold Time	$t_{CSH0}$	Applies to inactive SCLK falling edge preceding the first SCLK falling edge	0			ns
CSB Rise to SCLK Fall Hold Time	$t_{CSH1}$	Applies to the 24th SCLK falling edge	0			ns
CSB Rise to SCLK Fall	$t_{CSA}$	Applies to the 24th SCLK falling edge, aborted sequence	12			ns
SCLK Fall to CSB Fall	$t_{CSF}$	Applies to 24th SCLK falling edge	100			ns
CSB Pulse Width High	$t_{CSPW}$		20			ns
DIN to SCLK Fall Setup Time	$t_{DS}$		5			ns
DIN to SCLK Fall Hold Time	$t_{DH}$		4.5			ns
$\overline{CLR}$ Pulse Width Low	$t_{CLPW}$		20			ns
$\overline{CLR}$ Rise to CSB Fall	$t_{CSC}$	Required for command to be executed	20			ns
$\overline{LDAC}$ Pulse Width Low	$t_{LDPW}$		20			ns
$\overline{LDAC}$ Fall to SCLK Fall Hold	$t_{LDH}$	Applies to 24th SCLK falling edge,	20			ns

# MAX5713/MAX5714/MAX5715

## Ultra-Small, Quad-Channel, 8-/10-/12-Bit Buffered Output DACs with Internal Reference and SPI Interface

### ELECTRICAL CHARACTERISTICS (continued)

( $V_{DD} = 2.7V$  to  $5.5V$ ,  $V_{DDIO} = 1.8V$  to  $5.5V$ ,  $V_{GND} = 0V$ ,  $C_L = 200pF$ ,  $R_L = 2k\Omega$ ,  $T_A = -40^\circ C$  to  $+125^\circ C$ , unless otherwise noted. Typical values are at  $T_A = +25^\circ C$ .) (Note 3)

PARAMETER	SYMBOL	CONDITIONS	MIN	TYP	MAX	UNITS
SCLK Fall to $\overline{RDY}$ Fall	$t_{CRF}$	Applies to 24th SCLK falling edge, $C_{LOAD} = 20pF$			40	ns
SCLK Fall to $\overline{RDY}$ Hold	$t_{CRH}$	Applies to 24th SCLK falling edge, $C_{LOAD} = 0pF$	2			ns
CSB Rise to $\overline{RDY}$ Rise	$t_{CSR}$	$C_{LOAD} = 20pF$ (Note 13)			40	ns

**Note 3:** Electrical specifications are production tested at  $T_A = +25^\circ C$ . Specifications over the entire operating temperature range are guaranteed by design and characterization. Typical specifications are at  $T_A = +25^\circ C$  and are not guaranteed.

**Note 4:** DC Performance is tested without load.

**Note 5:** Linearity is tested with unloaded outputs to within 20mV of GND and  $V_{DD}$ .

**Note 6:** Offset and gain errors are calculated from measurements made with  $V_{REF} = V_{DD}$  at code 30 and 4065 for MAX5715, code 8 and 1016 for MAX5714, and code 2 and 254 for MAX5713.

**Note 7:** Subject to zero and full-scale error limits and  $V_{REF}$  settings.

**Note 8:** Measured with all other DAC outputs at midscale with one channel transitioning 0 to full scale.

**Note 9:** On power-up, the device initiates an internal 200 $\mu s$  (typ) calibration sequence. All commands issued during this time will be ignored.

**Note 10:** Guaranteed by design.

**Note 11:** All channels active at  $V_{FS}$ , unloaded. Static logic inputs with  $V_{IL} = V_{GND}$  and  $V_{IH} = V_{DDIO}$ .

**Note 12:** Daisy-chain speed is relaxed to accommodate ( $t_{CRF} + t_{CSS0}$ ) with margin (derived specification, not production tested).

**Note 13:** This specification and its propagation through the chain limits how quickly an aborted daisy-chain command can be followed by another daisy-chain command, to be applied on a per-device basis.

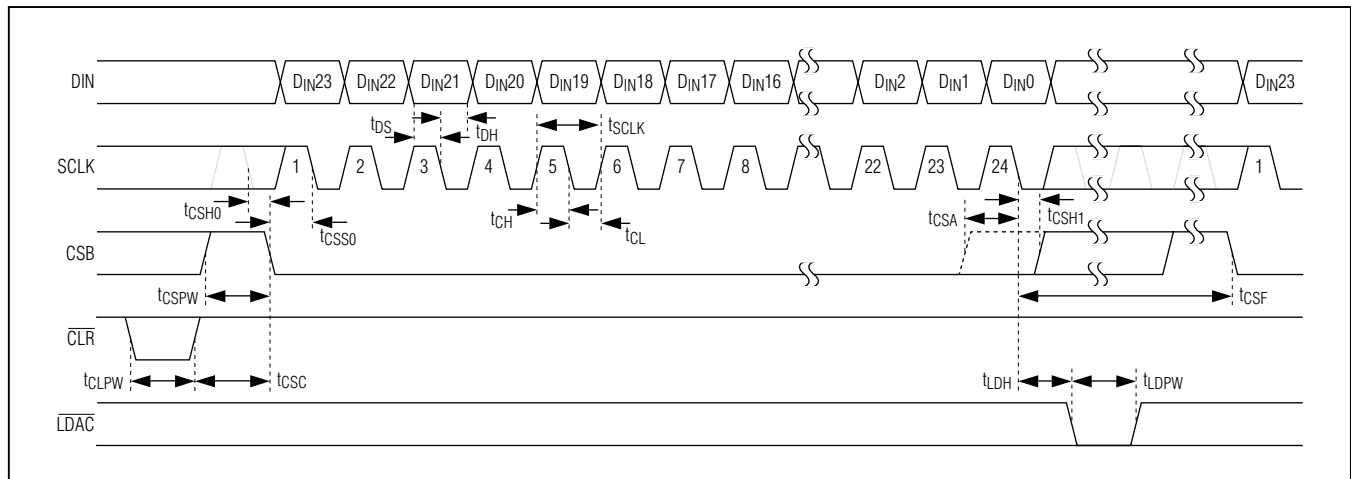

Figure 1. SPI Serial Interface Timing Diagram

# MAX5713/MAX5714/MAX5715

## Ultra-Small, Quad-Channel, 8-/10-/12-Bit Buffered Output DACs with Internal Reference and SPI Interface

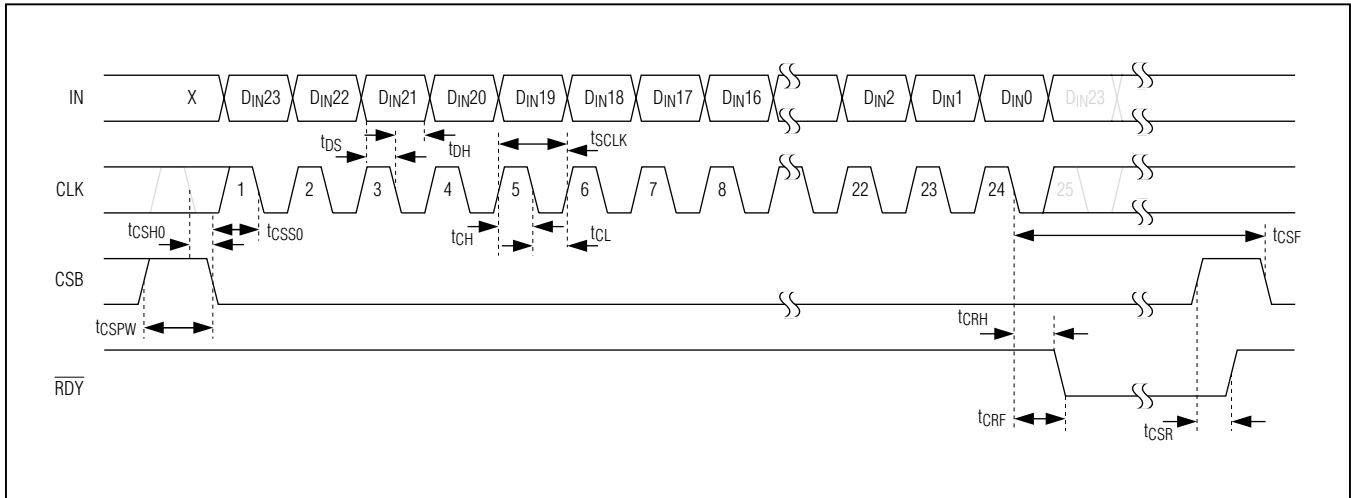
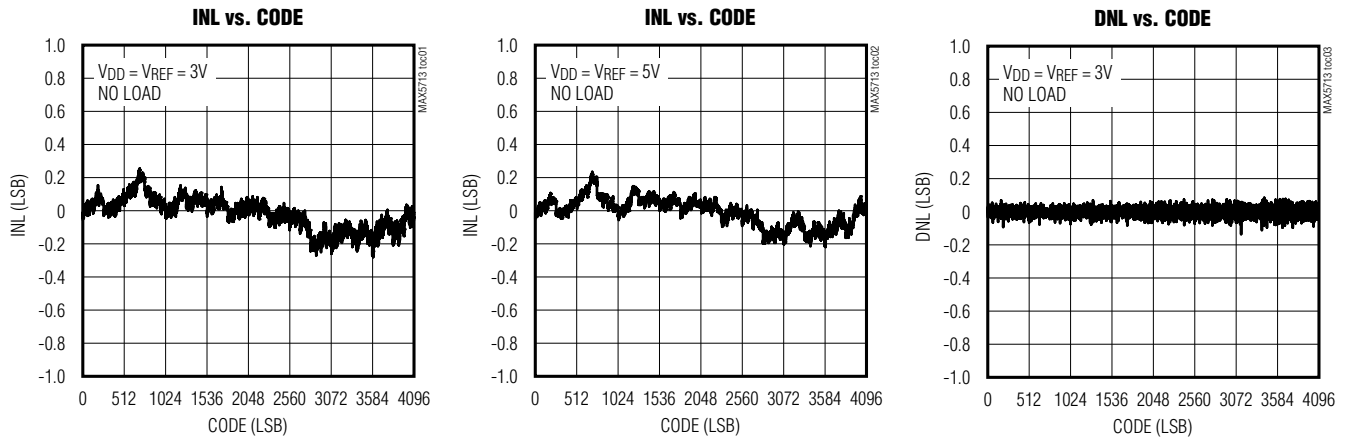

Figure 2. Elongated SPI Serial Interface Timing Diagram (Daisy-Chain Applications, TSSOP Package Only)

### Typical Operating Characteristics

(MAX5715, 12-bit performance,  $T_A = +25^\circ\text{C}$ , unless otherwise noted.)





# MAX5713/MAX5714/MAX5715

## Ultra-Small, Quad-Channel, 8-/10-/12-Bit Buffered Output DACs with Internal Reference and SPI Interface

### Typical Operating Characteristics (continued)

(MAX5715, 12-bit performance,  $T_A = +25^\circ\text{C}$ , unless otherwise noted.)

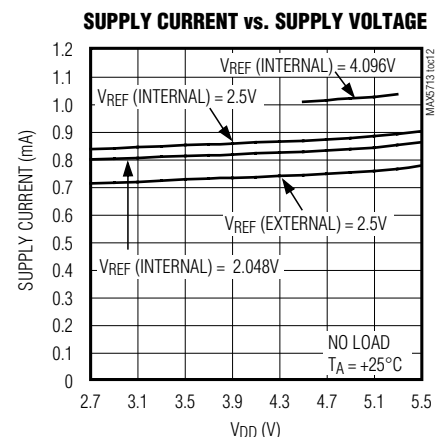
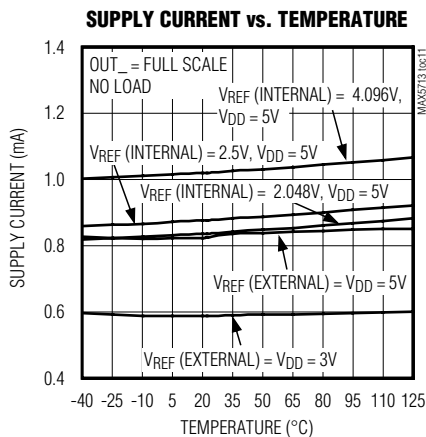
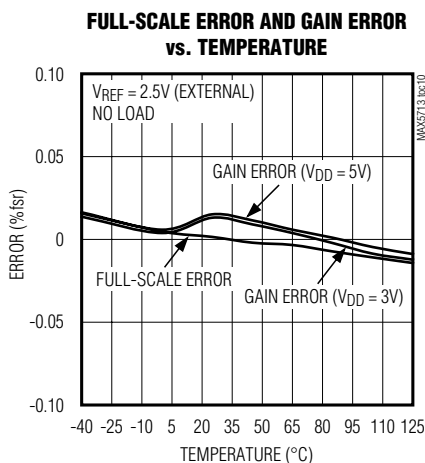
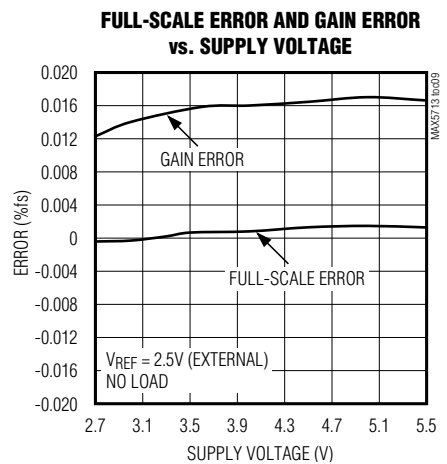
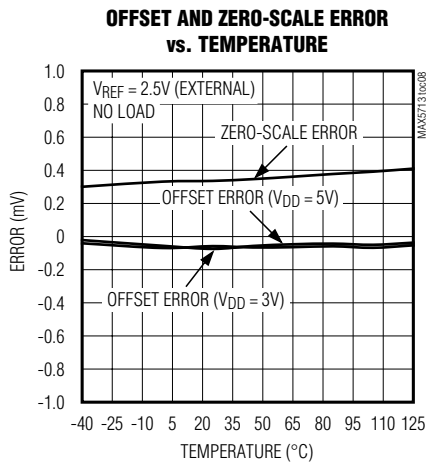
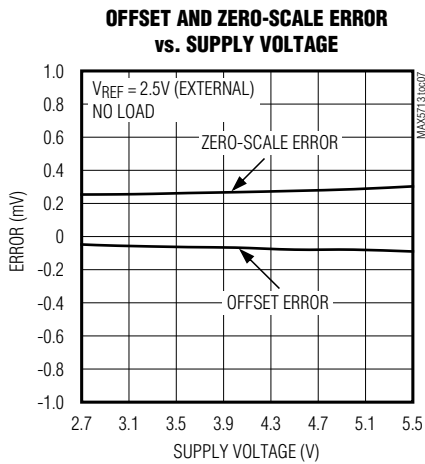
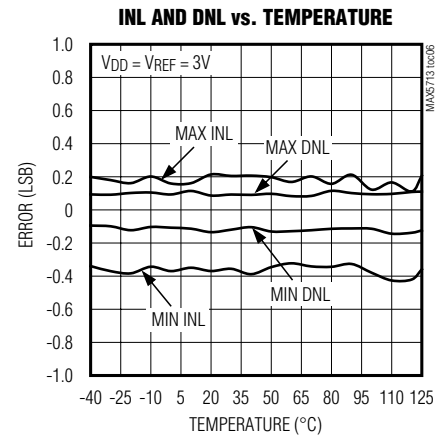
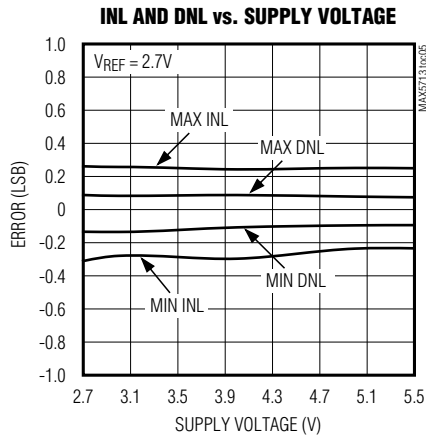
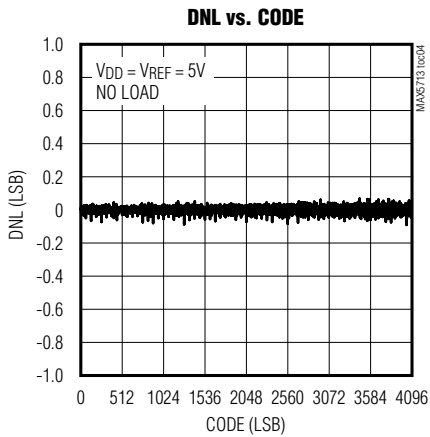

# MAX5713/MAX5714/MAX5715

## Ultra-Small, Quad-Channel, 8-/10-/12-Bit Buffered Output DACs with Internal Reference and SPI Interface

### Typical Operating Characteristics (continued)

(MAX5715, 12-bit performance,  $T_A = +25^\circ\text{C}$ , unless otherwise noted.)

**POWER-DOWN MODE SUPPLY CURRENT vs. TEMPERATURE**

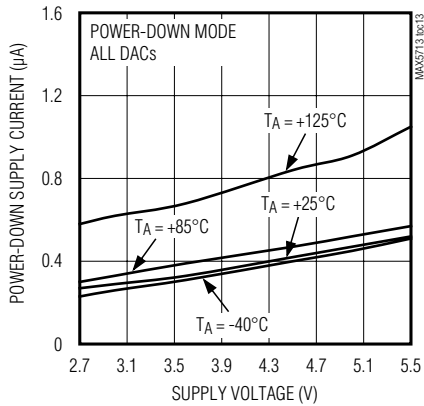

**SUPPLY CURRENT vs. CODE**

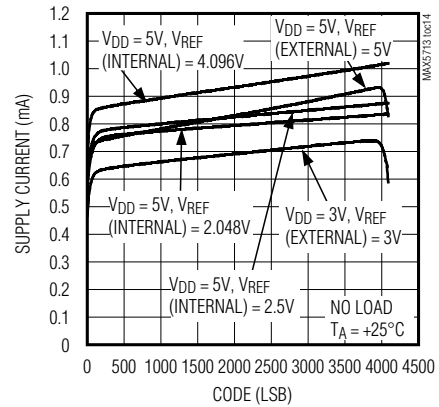

**IREF (EXTERNAL) vs. CODE**

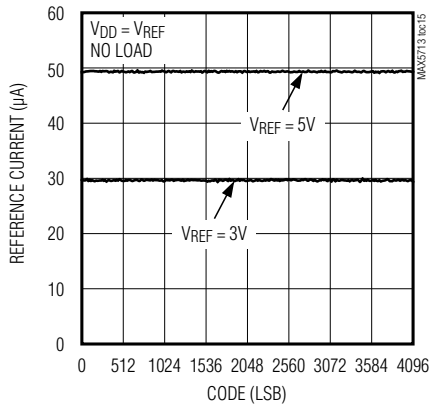

**SETTLING TO  $\pm 1$  LSB**  
( $V_{DD} = V_{REF} = 5\text{V}$ ,  $R_L = 2\text{k}\Omega$ ,  $C_L = 200\text{pF}$ )

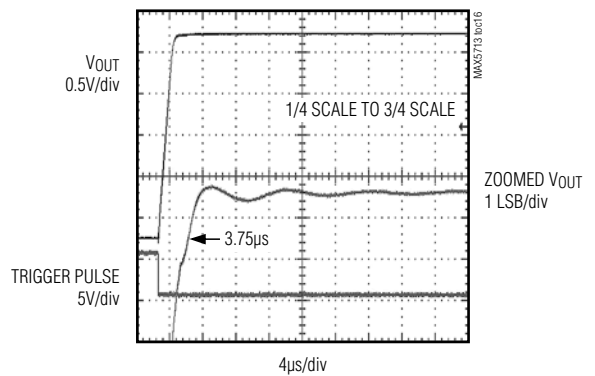

**SETTLING TO  $\pm 1$  LSB**  
( $V_{DD} = V_{REF} = 5\text{V}$ ,  $R_L = 2\text{k}\Omega$ ,  $C_L = 200\text{pF}$ )

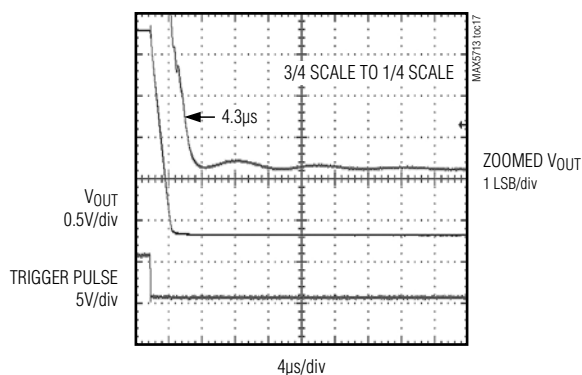

**MAJOR CODE TRANSITION**  
**GLITCH ENERGY**  
( $V_{DD} = V_{REF} = 5\text{V}$ ,  $R_L = 2\text{k}\Omega$ ,  $C_L = 200\text{pF}$ )

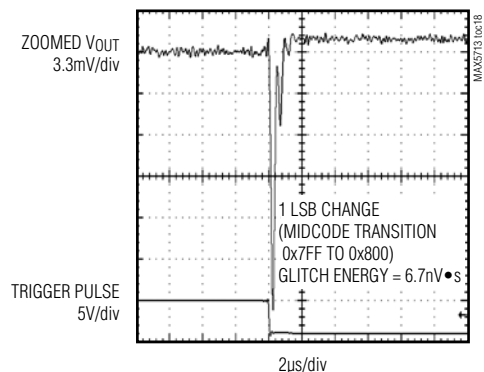

# MAX5713/MAX5714/MAX5715

## Ultra-Small, Quad-Channel, 8-/10-/12-Bit Buffered Output DACs with Internal Reference and SPI Interface

### Typical Operating Characteristics (continued)

(MAX5715, 12-bit performance,  $T_A = +25^\circ\text{C}$ , unless otherwise noted.)

**MAJOR CODE TRANSITION  
GLITCH ENERGY**  
( $V_{DD} = V_{REF} = 5\text{V}$ ,  $R_L = 2\text{k}\Omega$ ,  $C_L = 200\text{pF}$ )

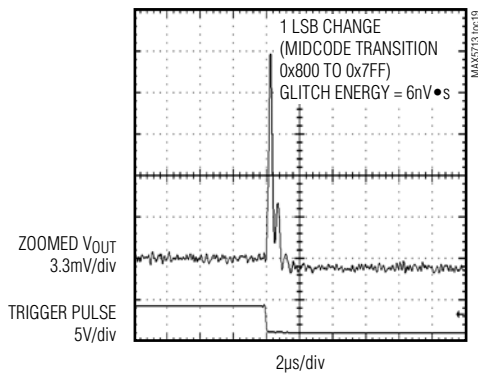

**$V_{OUT}$  vs. TIME TRANSIENT  
EXITING POWER-DOWN**

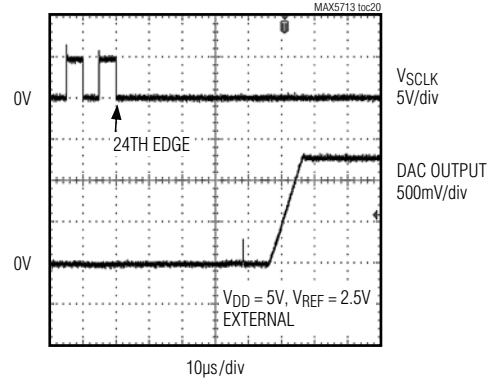

**POWER-ON RESET TO 0V**

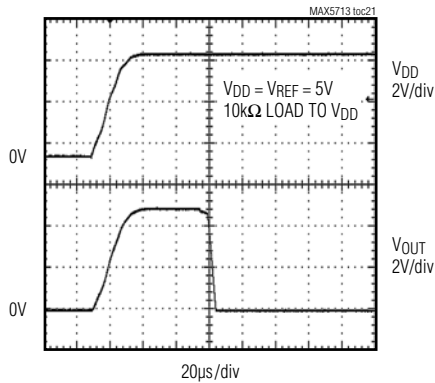

**CHANNEL-TO-CHANNEL FEEDTHROUGH**  
( $V_{DD} = V_{REF} = 5\text{V}$ ,  $T_A = +25^\circ\text{C}$ ,  
 $R_L = 2\text{k}\Omega$ ,  $C_L = 200\text{pF}$ )

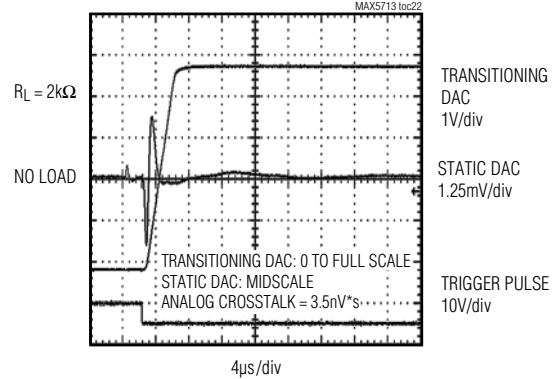

**CHANNEL-TO-CHANNEL FEEDTHROUGH**  
( $V_{DD} = V_{REF} = 5\text{V}$ ,  $T_A = +25^\circ\text{C}$ , NO LOAD)

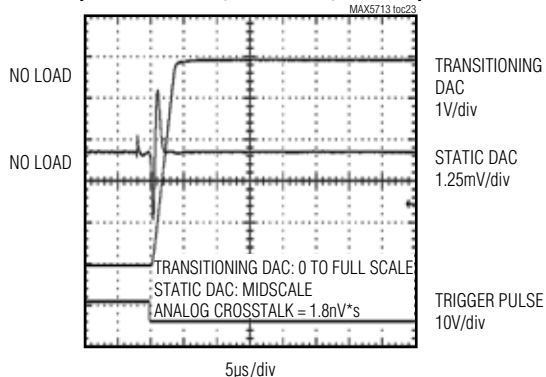

**CHANNEL-TO-CHANNEL FEEDTHROUGH**  
( $V_{DD} = 5\text{V}$ ,  $V_{REF} = 4.096\text{V}$  (INTERNAL),  
 $T_A = +25^\circ\text{C}$ ,  $R_L = 2\text{k}\Omega$ ,  $C_L = 200\text{pF}$ )

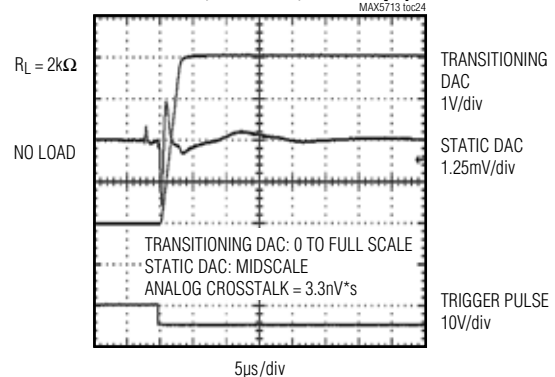

# MAX5713/MAX5714/MAX5715

## Ultra-Small, Quad-Channel, 8-/10-/12-Bit Buffered Output DACs with Internal Reference and SPI Interface

### Typical Operating Characteristics (continued)

(MAX5715, 12-bit performance,  $T_A = +25^\circ\text{C}$ , unless otherwise noted.)

**CHANNEL-TO-CHANNEL FEEDTHROUGH**  
**( $V_{DD} = 5\text{V}$ ,  $V_{REF} = 4.096\text{V}$  (INTERNAL),  
 $T_A = +25^\circ\text{C}$ , NO LOAD)**

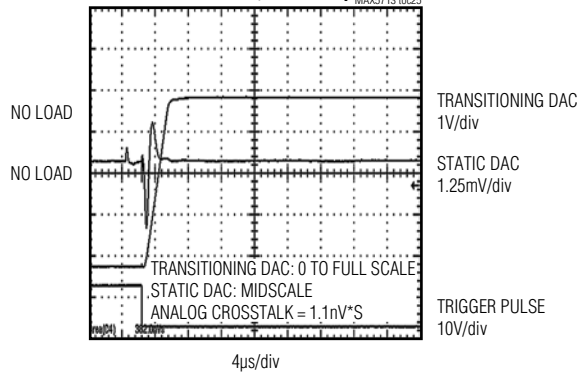

**DIGITAL FEEDTHROUGH**

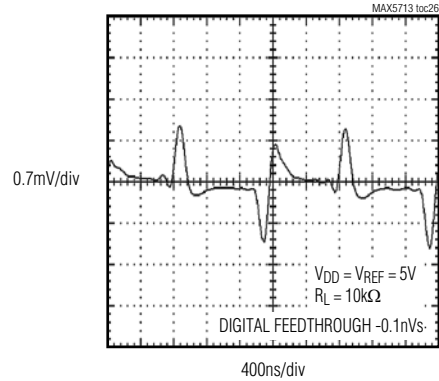

**OUTPUT LOAD REGULATION**

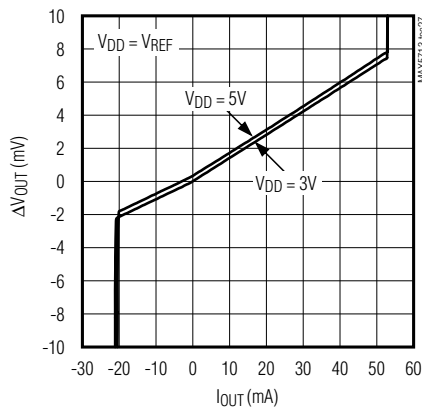

**OUTPUT CURRENT LIMITING**

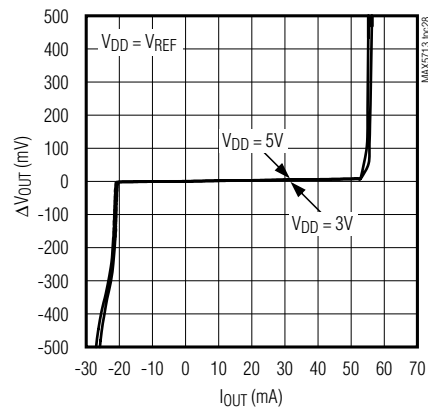

**HEADROOM AT RAILS**  
**vs. OUTPUT CURRENT ( $V_{DD} = V_{REF}$ )**

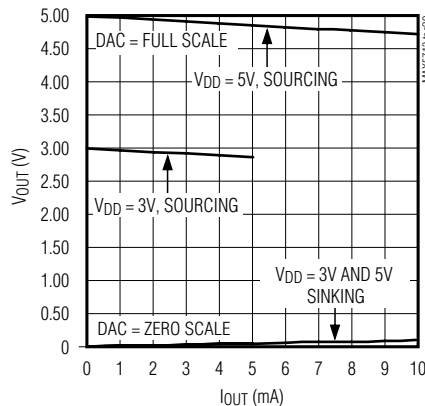

**NOISE-VOLTAGE DENSITY**  
**vs. FREQUENCY (DAC AT MIDSACLE)**

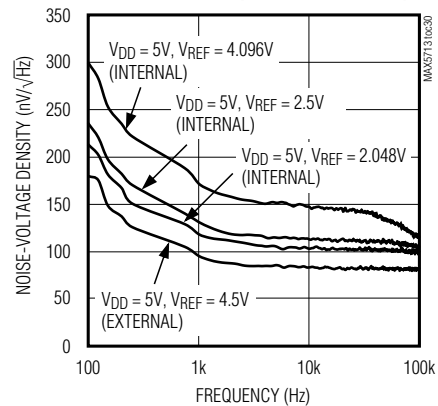

# MAX5713/MAX5714/MAX5715

## Ultra-Small, Quad-Channel, 8-/10-/12-Bit Buffered Output DACs with Internal Reference and SPI Interface

### Typical Operating Characteristics (continued)

(MAX5715, 12-bit performance,  $T_A = +25^\circ\text{C}$ , unless otherwise noted.)

**0.1Hz TO 10Hz OUTPUT NOISE, EXTERNAL REFERENCE ( $V_{DD} = 5V$ ,  $V_{REF} = 4.5V$ )**

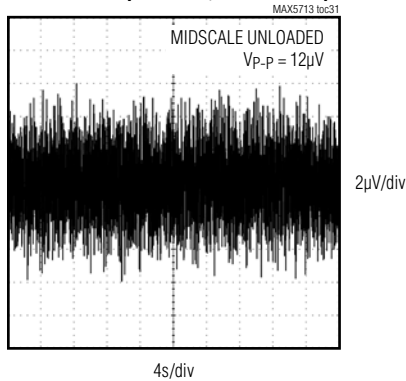

**0.1Hz TO 10Hz OUTPUT NOISE, INTERNAL REFERENCE ( $V_{DD} = 5V$ ,  $V_{REF} = 2.048V$ )**

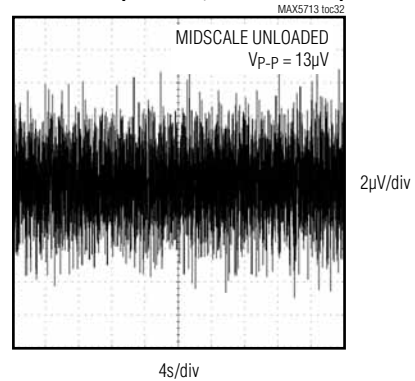

**0.1Hz TO 10Hz OUTPUT NOISE, INTERNAL REFERENCE ( $V_{DD} = 5V$ ,  $V_{REF} = 2.5V$ )**

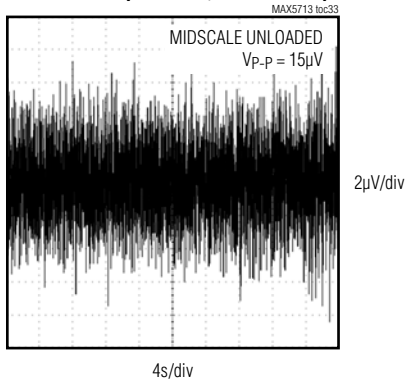

**0.1Hz TO 10Hz OUTPUT NOISE, INTERNAL REFERENCE ( $V_{DD} = 5V$ ,  $V_{REF} = 4.096V$ )**

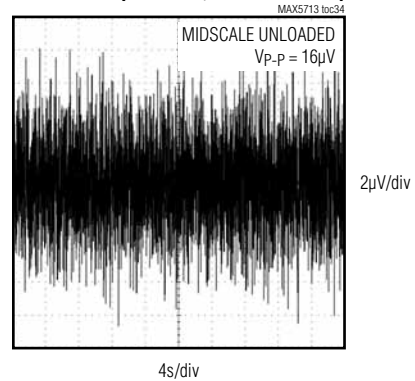

**VREF DRIFT vs. TEMPERATURE**

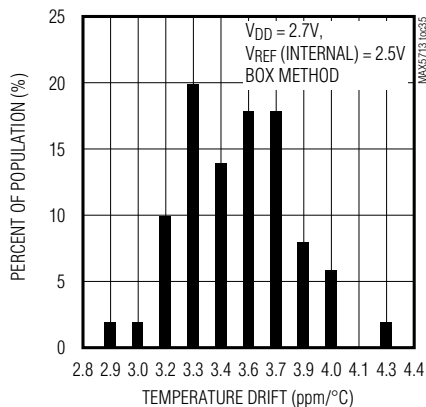

**REFERENCE LOAD REGULATION**

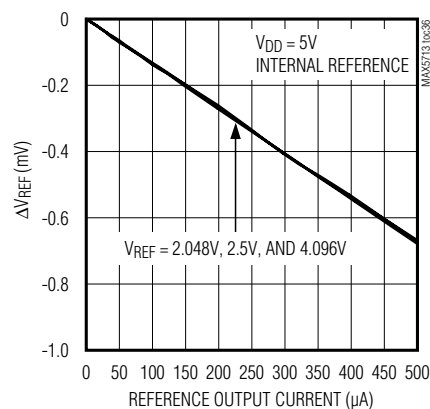

**SUPPLY CURRENT vs. LOGIC VOLTAGE**

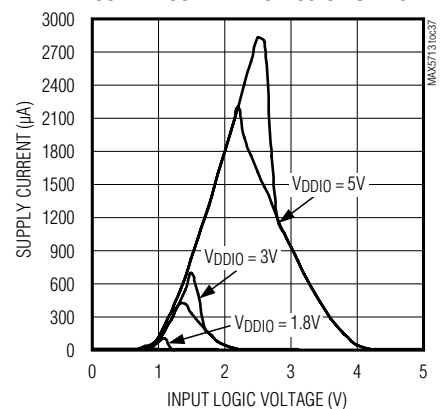

# MAX5713/MAX5714/MAX5715

## Ultra-Small, Quad-Channel, 8-/10-/12-Bit Buffered Output DACs with Internal Reference and SPI Interface

### Pin/Bump Configurations

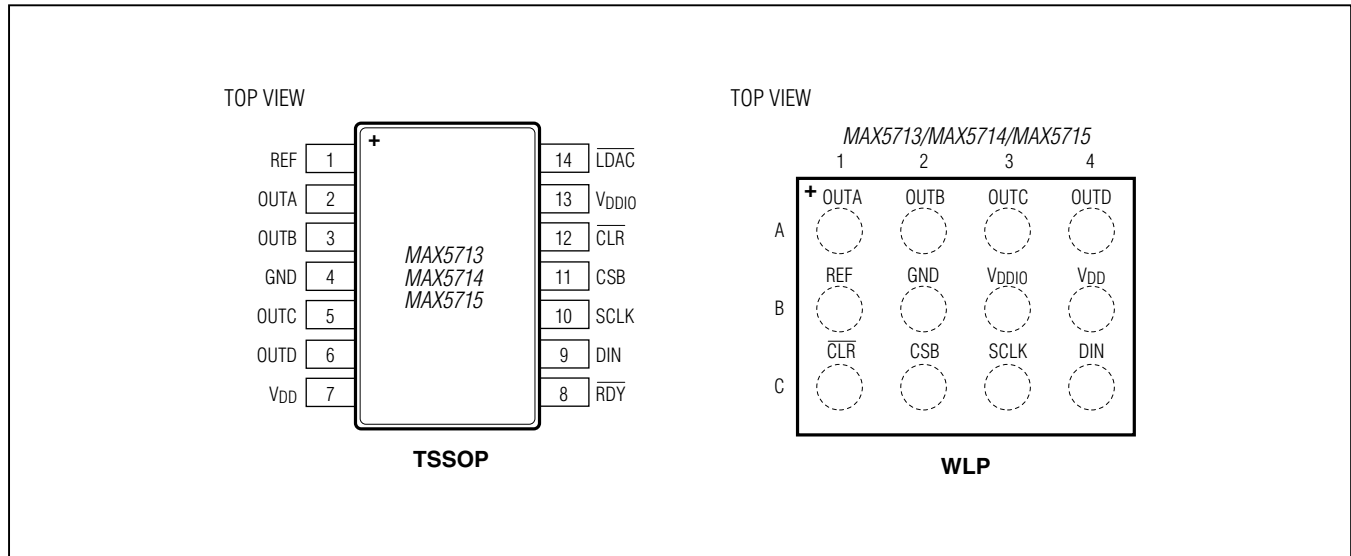

### Pin/Bump Description

PIN	BUMP	NAME	FUNCTION
TSSOP	WLP		
1	B1	REF	Reference Voltage Input/Output
2	A1	OUTA	Buffered Channel A DAC Output
3	A2	OUTB	Buffered Channel B DAC Output
4	B2	GND	Ground
5	A3	OUTC	Buffered Channel C DAC Output
6	A4	OUTD	Buffered Channel D DAC Output
7	B4	V <sub>DD</sub>	Supply Voltage Input. Bypass V <sub>DD</sub> with a 0.1μF capacitor to GND.
8	—	$\overline{\text{RDY}}$	SPI $\overline{\text{RDY}}$ Output. In daisy-chained applications connect $\overline{\text{RDY}}$ to the CSB of the next device in the chain.
9	C4	DIN	SPI Interface Data Input
10	C3	SCLK	SPI Interface Clock Input
11	C2	CSB	SPI Chip-Select Input
12	C1	$\overline{\text{CLR}}$	Active-Low Clear Input
13	B3	V <sub>DDIO</sub>	Digital Interface Power-Supply Input
14	—	$\overline{\text{LDAC}}$	Load DAC. Active-low hardware load DAC input.

# MAX5713/MAX5714/MAX5715

## Ultra-Small, Quad-Channel, 8-/10-/12-Bit Buffered Output DACs with Internal Reference and SPI Interface

### **Detailed Description**

The MAX5713/MAX5714/MAX5715 are 4-channel, low-power, 8-/10-/12-bit buffered voltage-output DACs. The 2.7V to 5.5V wide supply voltage range and low-power consumption accommodates most low-power and low-voltage applications. The devices present a 100k $\Omega$  load to the external reference. The internal output buffers allow rail-to-rail operation. An internal voltage reference is available with software selectable options of 2.048V, 2.5V, or 4.096V. The devices feature a 50MHz, 3-wire SPI/QSPI/MICROWIRE/DSP-compatible serial interface to save board space and reduce the complexity in isolated applications. The MAX5713/MAX5714/MAX5715 include a serial-in/parallel-out shift register, internal CODE and DAC registers, a power-on-reset (POR) circuit to initialize the DAC outputs to code zero, and control logic.  $\overline{\text{CLR}}$  is available to asynchronously clear the device independent of the serial interface.

### **DAC Outputs (OUT<sub>n</sub>)**

The MAX5713/MAX5714/MAX5715 include internal buffers on all DAC outputs. The internal output buffers provide improved load regulation for the DAC outputs. The output buffers slew at 1V/ $\mu\text{s}$  (typ) and drive resistive loads as low as 2k $\Omega$  in parallel with as much as 500pF of capacitance. The analog supply voltage ( $V_{\text{DD}}$ ) determines the maximum output voltage range of the devices as  $V_{\text{DD}}$  powers the output buffer. Under no-load conditions, the output buffers drive from GND to  $V_{\text{DD}}$ , subject to offset and gain errors. With a 2k $\Omega$  load to GND, the output buffers drive from GND to within 200mV of  $V_{\text{DD}}$ . With a 2k $\Omega$  load to  $V_{\text{DD}}$ , the output buffers drive from  $V_{\text{DD}}$  to within 200mV of GND.

The DAC ideal output voltage is defined by:

$$V_{\text{OUT}} = V_{\text{REF}} \times \frac{D}{2^N}$$

where D = code loaded into the DAC register,  $V_{\text{REF}}$  = reference voltage, N = resolution.

### **Internal Register Structure**

The user interface is separated from the DAC logic to minimize digital feedthrough. Within the serial interface is an input shift register, the contents of which can be routed to control registers, individual, or multiple DACs as determined by the user command.

Within each DAC channel there is a CODE register followed by a DAC latch register (see the *Detailed Functional Diagram*). The contents of the CODE register

hold pending DAC output settings which can later be loaded into the DAC registers. The CODE register can be updated using both CODE and CODE\_LOAD user commands. The contents of the DAC register hold the current DAC output settings. The DAC register can be updated directly from the serial interface using the CODE\_LOAD commands or can upload the current contents of the CODE register using LOAD commands or the  $\overline{\text{LDAC}}$  hardware pin.

The contents of both CODE and DAC registers are maintained during power-down states, so that when the DACs are powered on, they return to their previously stored output settings. Any CODE or LOAD commands issued during power-down states continue to update the register contents. SW\_CLEAR and SW\_RESET commands reset the contents of all CODE and DAC registers to their zero-scale defaults.

### **Internal Reference**

The MAX5713/MAX5714/MAX5715 include an internal precision voltage reference that is software selectable to be 2.048V, 2.500V, or 4.096V. When an internal reference is selected, that voltage is available on the REF pin for other external circuitry (see the [Typical Operating Circuits](#)) and can drive a 25k $\Omega$  load.

### **External Reference**

The external reference input has a typical input impedance of 100k $\Omega$  and accepts an input voltage from +1.24V to  $V_{\text{DD}}$ . Connect an external voltage supply between REF and GND to apply an external reference. The MAX5713/MAX5714/MAX5715 power up and reset to external reference mode. Visit [www.maximintegrated.com/products/references](http://www.maximintegrated.com/products/references) for a list of available external voltage-reference devices.

### **Load DAC ( $\overline{\text{LDAC}}$ ) Input (TSSOP Package Only)**

The MAX5713/MAX5714/MAX5715 feature an active-low  $\overline{\text{LDAC}}$  logic input that allows the outputs to update asynchronously. Connect  $\overline{\text{LDAC}}$  to  $V_{\text{DDIO}}$  or keep  $\overline{\text{LDAC}}$  high during normal operation when the device is controlled only through the serial interface. Drive  $\overline{\text{LDAC}}$  low to simultaneously update the DAC outputs with data from the CODE registers. Holding  $\overline{\text{LDAC}}$  low causes the DAC registers to become transparent and CODE data is passed through to the DAC registers immediately updating the DAC outputs. A software CONFIG command can be used to configure the  $\overline{\text{LDAC}}$  operation of each DAC independently.

# MAX5713/MAX5714/MAX5715

## Ultra-Small, Quad-Channel, 8-/10-/12-Bit Buffered Output DACs with Internal Reference and SPI Interface

### Clear Input ( $\overline{\text{CLR}}$ )

The MAX5713/MAX5714/MAX5715 feature an asynchronous active-low  $\overline{\text{CLR}}$  logic input that simultaneously sets all four DAC outputs to zero. Driving  $\overline{\text{CLR}}$  low clears the contents of both the CODE and DAC registers and also aborts the on-going SPI command. To allow a new SPI command, drive  $\overline{\text{CLR}}$  high, satisfying the  $t_{\text{CSC}}$  timing requirement.

### Interface Power Supply ( $V_{\text{DDIO}}$ )

The MAX5713/MAX5714/MAX5715 feature a separate supply pin ( $V_{\text{DDIO}}$ ) for the digital interface (1.8V to 5.5V). Connect  $V_{\text{DDIO}}$  to the I/O supply of the host processor.

### SPI Serial Interface

The MAX5713/MAX5714/MAX5715 3-wire serial interface is compatible with MICROWIRE, SPI, QSPI, and DSPs. The interface provides three inputs, SCLK, CSB, and DIN. The chip-select input (CSB, active low) frames the data loaded through the serial data input (DIN). Following a CSB input high-to-low transition, the data is shifted in synchronously and latched into the input register on each falling edge of the serial clock input (SCLK). Each serial operation word is 24-bits long. The DAC data is left justified as shown in Table 1. The serial input register transfers its contents to the destination registers after loading 24 bits of data on the 24th SCLK falling edge. To initiate a new SPI operation, drive CSB high and then low to begin the next operation sequence, being sure to meet all relevant timing requirements. During CSB high periods, SCLK is ignored, allowing communication to other devices on the same bus. SPI operations consist-

ing of more than 24 SCLK cycles are executed on the 24th SCLK falling edge, using the first three bytes of data available. SPI operations consisting of less than 24 SCLK cycles will not be executed. The content of the SPI operation consists of a command byte followed by a two byte data word.

Figure 1 shows the timing diagram for the complete 3-wire serial interface transmission. The DAC code settings (D) for the MAX5713/MAX5714/MAX5715 are accepted in an offset binary format (see Table 1). Otherwise, the expected data format for each command is listed in Table 2. See Figure 3 for an example of a typical SPI circuit application.

### SPI Daisy Chain/ $\overline{\text{RDY}}$ Output (TSSOP Package Only)

The elongated programming operation is typically used for devices in daisy-chain applications. The  $\overline{\text{RDY}}$  output in the TSSOP version of the MAX5713/MAX5714/MAX5715 feeds the CSB input of the next device in the daisy-chain. The MAX5713/MAX5714/MAX5715 pulls the  $\overline{\text{RDY}}$  output low on the 24th SCLK falling edge, allowing the next device in the chain to begin its SPI operation, commencing with the 25th SCLK falling edge. See Figure 2 for timing characteristics of the elongated SPI programming operation. In practice ( $t_{\text{CRF}} + t_{\text{CSS0}}$ ) requirements will limit the daisy-chain SPI speed. Also in daisy-chain applications, a partial write to the chain is possible as long as the  $t_{\text{CSA}}$  is met for the first device the user chooses not to program. See Figure 4 for an example of a daisy-chain circuit application.

**Table 1. Format DAC Data Bit Positions**

PART	B15	B14	B13	B12	B11	B10	B9	B8	B7	B6	B5	B4	B3	B2	B1	B0
MAX5713	D7	D6	D5	D4	D3	D2	D1	D0	x	x	x	x	x	x	x	x
MAX5714	D9	D8	D7	D6	D5	D4	D3	D2	D1	D0	x	x	x	x	x	x
MAX5715	D11	D10	D9	D8	D7	D6	D5	D4	D3	D2	D1	D0	x	x	x	x



# MAX5713/MAX5714/MAX5715

## Ultra-Small, Quad-Channel, 8-/10-/12-Bit Buffered Output DACs with Internal Reference and SPI Interface

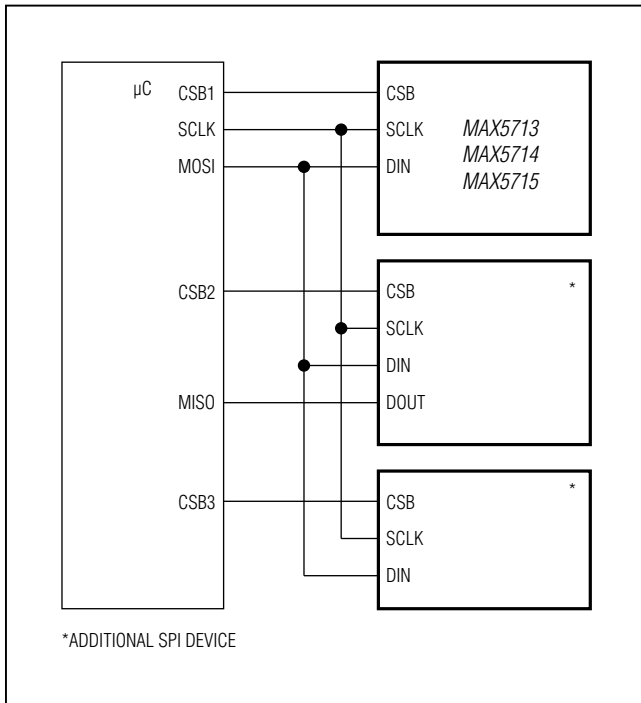

Figure 3. Typical SPI Application Circuit

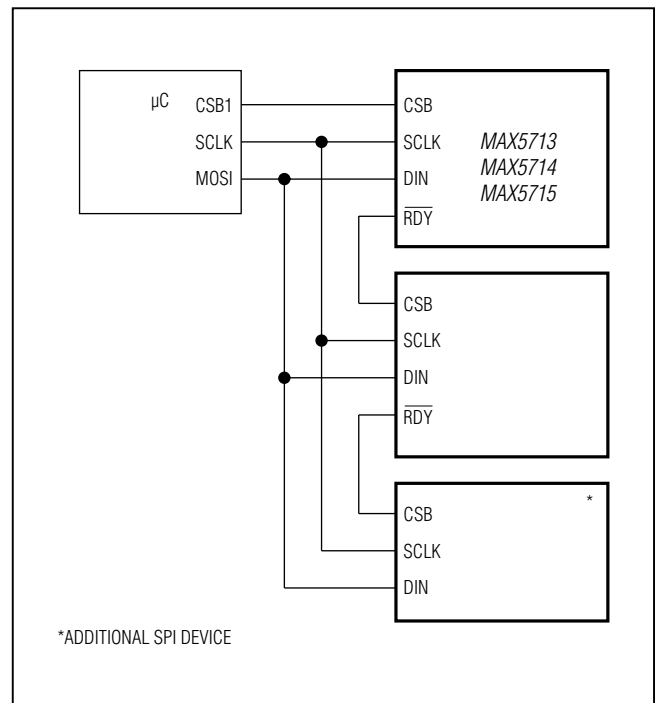

Figure 4. Typical SPI Daisy-Chain Application Circuit

### SPI User-Command Register Map

This section lists the user accessible commands and registers for the MAX5713/MAX5714/MAX5715.

[Table 2](#) provides detailed information about the Command Registers.

# MAX5713/MAX5714/MAX5715

## Ultra-Small, Quad-Channel, 8-/10-/12-Bit Buffered Output DACs with Internal Reference and SPI Interface

**Table 2. SPI Commands Summary**

COMMAND	B23	B22	B21	B20	B19	B18	B17	B16	B15	B14	B13	B12	B11	B10	B9	B8	B7	B6	B5	B4	B3	B2	B1	B0	DESCRIPTION	
<b>DAC COMMANDS</b>																										
CODEn	0	0	0	0															CODE REGISTER DATA [3:0]					X	Writes data to the selected CODE register(s)	
LOADn	0	0	0	1		DAC SELECTION			X	X	X	X	X	X	X	X	X	X	X					X	Transfers data from the selected CODE register(s) to the selected DAC register(s)	
CODEn_LOAD_ALL	0	0	1	0		DAC SELECTION													CODE REGISTER DATA [3:0]					X	Simultaneously writes data to the selected CODE register(s) while updating all DAC registers	
CODEn_LOADn	0	0	1	1		DAC SELECTION			X	X	X	X	X	X	X	X	X	X	CODE REGISTER DATA [3:0]					X	Simultaneously writes data to the selected CODE register(s) while updating selected DAC register(s)	
<b>CONFIGURATION COMMANDS</b>																										
POWER	0	1	0	0	0				X	X	X	X	X	X	DAC D	DAC C	DAC B	DAC A	X	X	X	X	X	X	X	Sets the power mode of the selected DACs (DACs selected with a 1 in the corresponding DACn bit are updated, DACs with a 0 in the corresponding DACn bit are not impacted)
SW_CLEAR	0	1	0	1	0	0	0	0	X	X	X	X	X	X					X	X	X	X	X	X	X	Executes a software clear (all CODE and DAC registers cleared to their default values)
SW_RESET	0	1	0	1	0	0	1	0	X	X	X	X	X	X					X	X	X	X	X	X	X	Executes a software reset (all CODE, DAC, and control registers returned to their default values)

# MAX5713/MAX5714/MAX5715

## Ultra-Small, Quad-Channel, 8-/10-/12-Bit Buffered Output DACs with Internal Reference and SPI Interface

Table 2. SPI Commands Summary (continued)

COMMAND	B23	B22	B21	B20	B19	B18	B17	B16	B15	B14	B13	B12	B11	B10	B9	B8	B7	B6	B5	B4	B3	B2	B1	B0	DESCRIPTION	
CONFIG	0	1	1	0	All DACs	0	0	LD_EN	X	X	X	X	DAC D	DAC C	DAC B	DAC A	X	X	X	X	X	X	X	X	Sets the DAC Latch Mode of the selected DACs. Only DACs with a 1 in the selection bit are updated by the command. LD_EN = 0: DAC latch is operational (LOAD and LDAC controlled) LD_EN = 1: DAC latch is transparent	
REF	0	1	1	1	0	REF Power 0 = DAC 1 = CN	REF Mode 00 = EXT 01 = 2.5V 10 = 2.0V 11 = 4.1V		X	X	X	X	X	X	X	X	X	X	X	X	X	X	X	X	Sets the reference operating mode. REF Power (B18): 0 = Internal reference is only powered if at least one DAC is powered 1 = Internal reference is always powered	
<b>ALL DAC COMMANDS</b>																										
CODE_ALL	1	0	0	0	0	0	0	0					CODE REGISTER DATA [11:4]												Writes data to all CODE registers	
LOAD_ALL	1	0	0	0	0	0	1		X	X	X	X	X	X	X	X	X	X	X	X	X	X	X	X	Updates all DAC latches with current CODE register data	
CODE_ALL_LOAD_ALL	1	0	0	0	0	0	1	X					CODE REGISTER DATA [11:4]												Simultaneously writes data to all CODE registers while updating all DAC registers	
<b>NO OPERATION COMMANDS</b>																										
No Operation	1	0	0	1	X	X	X	X	X	X	X	X	X	X	X	X	X	X	X	X	X	X	X	X	X	These commands will have no effect on the device
Reserved Commands: Any commands not specifically listed above are reserved for Maxim internal use only.																										

# MAX5713/MAX5714/MAX5715

## Ultra-Small, Quad-Channel, 8-/10-/12-Bit Buffered Output DACs with Internal Reference and SPI Interface

### **CODEn Command**

The CODEn command (B[23:20] = 0000) updates the CODE register contents for the selected DAC(s). Changes to the CODE register content based on this command will not affect DAC outputs directly unless the  $\overline{\text{LDAC}}$  is in a low state or the DAC latch has been configured to be transparent. Issuing the CODEn command with DAC SELECTION = ALL DACs is equivalent to CODE\_ALL (B[23:16] = 10000000). See [Table 2](#) and [Table 3](#).

### **LOADn Command**

The LOADn command (B[23:20] = 0001) updates the DAC register content for the selected DAC(s) by uploading the current contents of the CODE register. The LOADn command can be used with DAC SELECTION = ALL DACs to issue a software load for all DACs, which is equivalent to the LOAD\_ALL (B[23:16] = 10000001) command. See [Table 2](#) and [Table 3](#).

### **CODEn\_LOAD\_ALL Command**

The CODEn\_LOAD\_ALL command (B[23:20] = 0010) updates the CODE register contents for the selected DAC(s) as well as the DAC register content of all DACs. Channels for which the CODE register content has not been modified since the last load to DAC register or  $\overline{\text{LDAC}}$  operation will not be updated to reduce digital crosstalk. Issuing this command with DAC\_ADDRESS = ALL is equivalent to the CODE\_ALL\_LOAD\_ALL (B[23:16] = 1000001x) command. The CODEn\_LOAD\_ALL command by definition will modify at least one CODE reg-

ister. To avoid this, use the LOADn command with DAC SELECTION = ALL DACs or use the LOAD\_ALL command. See [Table 2](#) and [Table 3](#).

### **CODEn\_LOADn Command**

The CODEn\_LOADn command (B[23:20] = 0011) updates the CODE register contents for the selected DAC(s) as well as the DAC register content of the selected DAC(s). Channels for which the CODE register content has not been modified since the last load to DAC register or  $\overline{\text{LDAC}}$  operation will not be updated to reduce digital crosstalk. Issuing this command with DAC SELECTION = ALL DACs is equivalent to the CODE\_ALL\_LOAD\_ALL command. See [Table 2](#) and [Table 3](#).

### **CODE\_ALL Command**

The CODE\_ALL command (B[23:16] = 10000000) updates the CODE register contents for all DACs. See [Table 2](#).

### **LOAD\_ALL Command**

The LOAD\_ALL command (B[23:16] = 10000001) updates the DAC register content for all DACs by uploading the current contents of the CODE registers. See [Table 2](#).

### **CODE\_ALL\_LOAD\_ALL Command**

The CODE\_ALL\_LOAD\_ALL command (B[23:16] = 1000001x) updates the CODE register contents for all DACs as well as the DAC register content of all DACs. See [Table 2](#).

**Table 3. DAC Selection**

B19	B18	B17	B16	DAC SELECTED
0	0	0	0	DAC A
0	0	0	1	DAC B
0	0	1	0	DAC C
0	0	1	1	DAC D
X	1	X	X	ALL DACs
1	X	X	X	ALL DACs

# MAX5713/MAX5714/MAX5715

## Ultra-Small, Quad-Channel, 8-/10-/12-Bit Buffered Output DACs with Internal Reference and SPI Interface

### POWER Command

The MAX5713/MAX5714/MAX5715 feature a software-controlled power-mode (POWER) command (B[23:20] = 0100). The POWER command updates the power-mode settings of the selected DACs while the power settings of the rest of the DACs remain unchanged. The new power setting is determined by bits B[17:16] while the affected DAC(s) are selected by bits B[11:8]. If all DACs are powered down, the device enters a STANDBY mode.

In power-down, the DAC output is disconnected from the buffer and is grounded with either one of the two selectable internal resistors or set to high impedance. See [Table 5](#) for the selectable internal resistor values in power-down mode. In power-down mode, the DAC register retains its value so that the output is restored when the device powers up. The serial interface remains active in power-down mode.

In STANDBY mode, the internal reference can be powered down or it can be set to remain powered-on for external use. Also, in STANDBY mode, devices using the external reference do not load the REF pin. See [Table 4](#).

### SW\_RESET and SW\_CLEAR Command

The SW\_RESET (B[23:16] = 01010001) and SW\_CLEAR (B[23:16] = 01010000) commands provide a means of issuing a software reset or software clear operation. Use SW\_CLEAR to issue a software clear operation to return all CODE and DAC registers to the zero-scale value. Use SW\_RESET to reset all CODE, DAC, and configuration registers to their default values.

**Table 4. POWER (100) Command Format**

B23	B22	B21	B20	B19	B18	B17	B16	B15	B14	B13	B12	B11	B10	B9	B8	B7	B6	B5	B4	B3	B2	B1	B0	
0	1	0	0	0	0	PD1	PD0	X	X	X	X	D	C	B	A	X	X	X	X	X	X	X	X	
POWER Command						Power Mode: 00 = Normal 01 = 1kΩ 10 = 100kΩ 11 = Hi-Z		Don't Care				Multiple DAC Selection: 1 = DAC Selected 0 = DAC Not Selected				Don't Care								
Default Values (all DACs)						0	0	X	X	X	X	1	1	1	1	X	X	X	X	X	X	X	X	X

**Table 5. Selectable DAC Output Impedance in Power-Down Mode**

PD1 (B17)	PD0 (B16)	OPERATING MODE
0	0	Normal operation
0	1	Power-down with internal 1kΩ pulldown resistor to GND.
1	0	Power-down with internal 100kΩ pulldown resistor to GND.
1	1	Power-down with high-impedance output.

# MAX5713/MAX5714/MAX5715

## Ultra-Small, Quad-Channel, 8-/10-/12-Bit Buffered Output DACs with Internal Reference and SPI Interface

### CONFIG Command

The CONFIG command (B[23:20] = 0110) updates the LDAC and LOAD functions of selected DACs. Issue the command with B16 = 0 to allow the DAC latches to operate normally or with B16 = 1 to disable the DAC latches, making them perpetually transparent. Mode settings of the selected DACs are updated while the mode settings of the rest of the DACs remain unchanged; DAC(s) are selected by bits B[11:8]. See [Table 6](#).

### REF Command

The REF command updates the global reference setting used for all DAC channels. Set B[17:16] = 00 to use an external reference for the DACs or set B[17:16] to 01, 10, or 11 to select either the 2.5V, 2.048V, or 4.096V internal reference, respectively.

If RF2 (B18) is set to zero (default) in the REF command, the reference will be powered down any time all DAC channels are powered down (in STANDBY mode). If RF2 (B18 = 1) is set to one, the reference will remain powered even if all DAC channels are powered down, allowing continued operation of external circuitry. In this mode, the 1µA shutdown state is not available. See [Table 7](#).

**Table 6. CONFIG Command Format**

B23	B22	B21	B20	B19	B18	B17	B16	B15	B14	B13	B12	B11	B10	B9	B8	B7	B6	B5	B4	B3	B2	B1	B0	
0	1	1	0	All	0	0	LDB	X	X	X	X	D	C	B	A	X	X	X	X	X	X	X	X	
CONFIG Command				0 = Select Individual DACs 1 = Select All DACs	CONFIG Command		0 = Normal 1 = Transparent	Don't Care				Multiple DAC Selection: 1 = DAC Selected 0 = DAC Not Selected				Don't Care								
Default Values (all DACs)							0	X	X	X	X	1	1	1	1	X	X	X	X	X	X	X	X	X

**Table 7. REF Command Format**

B23	B22	B21	B20	B19	B18	B17	B16	B15	B14	B13	B12	B11	B10	B9	B8	B7	B6	B5	B4	B3	B2	B1	B0
0	1	1	1	0	RF2	RF1	RF0	X	X	X	X	X	X	X	X	X	X	X	X	X	X	X	X
REF Command				0 = Off in Standby 1 = On in Standby	REF Mode: 00 = EXT 01 = 2.5V 10 = 2.0V 11 = 4.0V			Don't Care								Don't Care							
Default Values					0	0	0	X	X	X	X	X	X	X	X	X	X	X	X	X	X	X	X

# MAX5713/MAX5714/MAX5715

## Ultra-Small, Quad-Channel, 8-/10-/12-Bit Buffered Output DACs with Internal Reference and SPI Interface

### Applications Information

---

#### Power-On Reset (POR)

When power is applied to  $V_{DD}$  and  $V_{DDIO}$ , the DAC output is set to zero scale. To optimize DAC linearity, wait until the supplies have settled and the internal setup and calibration sequence completes (200 $\mu$ s, typ).

#### Power Supplies and Bypassing Considerations

Bypass  $V_{DD}$  and  $V_{DDIO}$  with high-quality ceramic capacitors to a low-impedance ground as close as possible to the device. Minimize lead lengths to reduce lead inductance. Connect the GND to the analog ground plane.

#### Layout Considerations

Digital and AC transient signals on GND can create noise at the output. Connect GND to form the star ground for the DAC system. Refer remote DAC loads to this system ground for the best possible performance. Use proper grounding techniques, such as a multilayer board with a low-inductance ground plane, or star connect all ground return paths back to the MAX5713/MAX5714/MAX5715 GND. Carefully layout the traces between channels to reduce AC cross-coupling. Do not use wire-wrapped boards and sockets. Use shielding to minimize noise immunity. Do not run analog and digital signals parallel to one another, especially clock signals. Avoid routing digital lines underneath the MAX5713/MAX5714/MAX5715 package.

### Definitions

---

#### Integral Nonlinearity (INL)

INL is the deviation of the measured transfer function from a straight line drawn between two codes once offset and gain errors have been nullified.

#### Differential Nonlinearity (DNL)

DNL is the difference between an actual step height and the ideal value of 1 LSB. If the magnitude of the  $DNL \leq 1$  LSB, the DAC guarantees no missing codes and is monotonic. If the magnitude of the  $DNL \geq 1$  LSB, the DAC output may still be monotonic.

#### Offset Error

Offset error indicates how well the actual transfer function matches the ideal transfer function. The offset error is calculated from two measurements near zero code and near maximum code.

#### Gain Error

Gain error is the difference between the ideal and the actual full-scale output voltage on the transfer curve, after nullifying the offset error. This error alters the slope of the transfer function and corresponds to the same percentage error in each step.

#### Zero-Scale Error

Zero-scale error is the difference between the DAC output voltage when set to code zero and ground. This includes offset and other die level nonidealities.

#### Full-Scale Error

Full-scale error is the difference between the DAC output voltage when set to full scale and the reference voltage. This includes offset, gain error, and other die level nonidealities.

#### Settling Time

The settling time is the amount of time required from the start of a transition, until the DAC output settles to the new output value within the converter's specified accuracy.

#### Digital Feedthrough

Digital feedthrough is the amount of noise that appears on the DAC output when the DAC digital control lines are toggled.

#### Digital-to-Analog Glitch Impulse

A major carry transition occurs at the midscale point where the MSB changes from low to high and all other bits change from high to low, or where the MSB changes from high to low and all other bits change from low to high. The duration of the magnitude of the switching glitch during a major carry transition is referred to as the digital-to-analog glitch impulse.

The digital-to-analog power-up glitch is the duration of the magnitude of the switching glitch that occurs as the device exits power-down mode.

# MAX5713/MAX5714/MAX5715

## Ultra-Small, Quad-Channel, 8-/10-/12-Bit Buffered Output DACs with Internal Reference and SPI Interface

### Detailed Functional Diagram

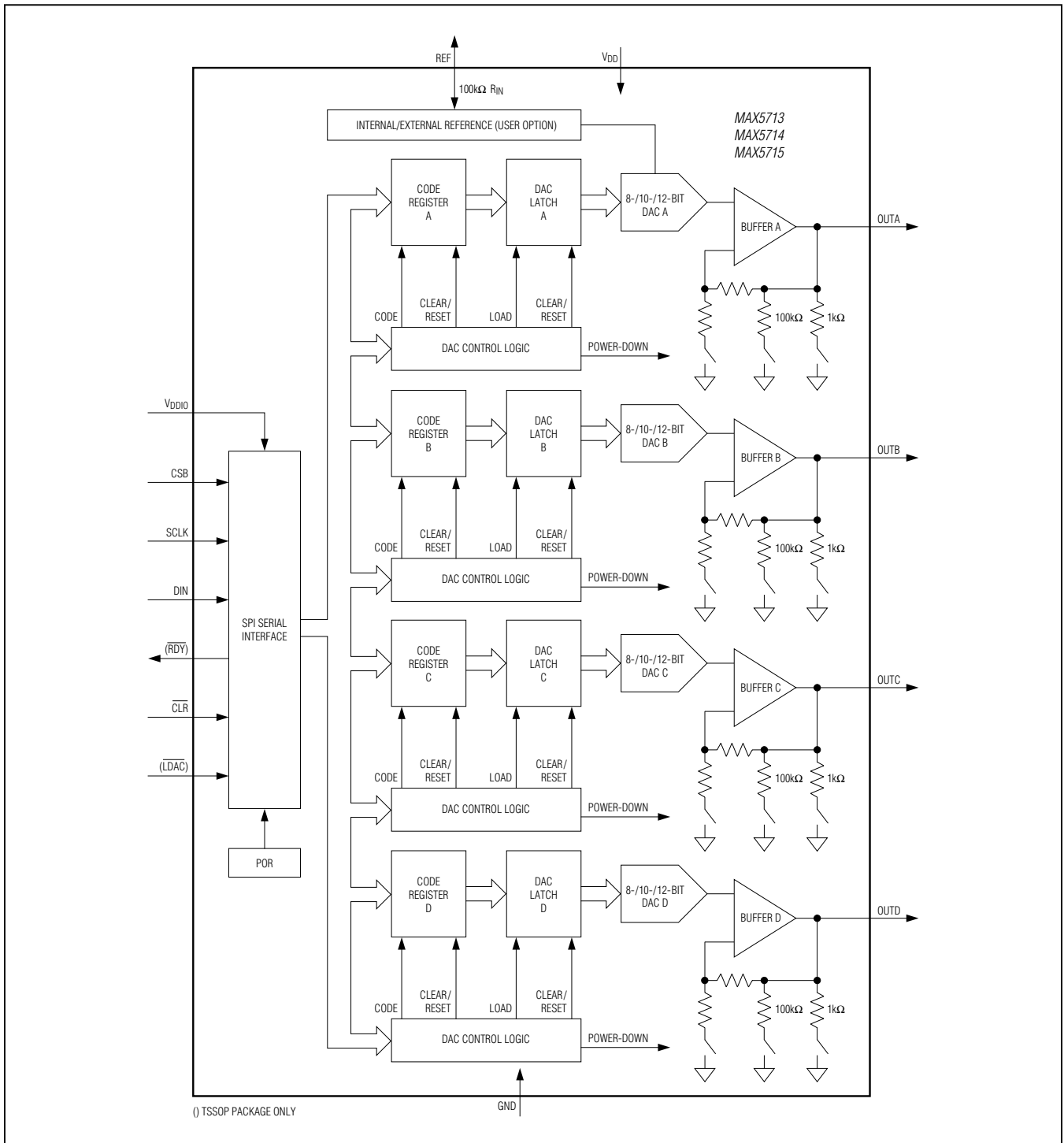



# MAX5713/MAX5714/MAX5715

## Ultra-Small, Quad-Channel, 8-/10-/12-Bit Buffered Output DACs with Internal Reference and SPI Interface

### Typical Operating Circuits

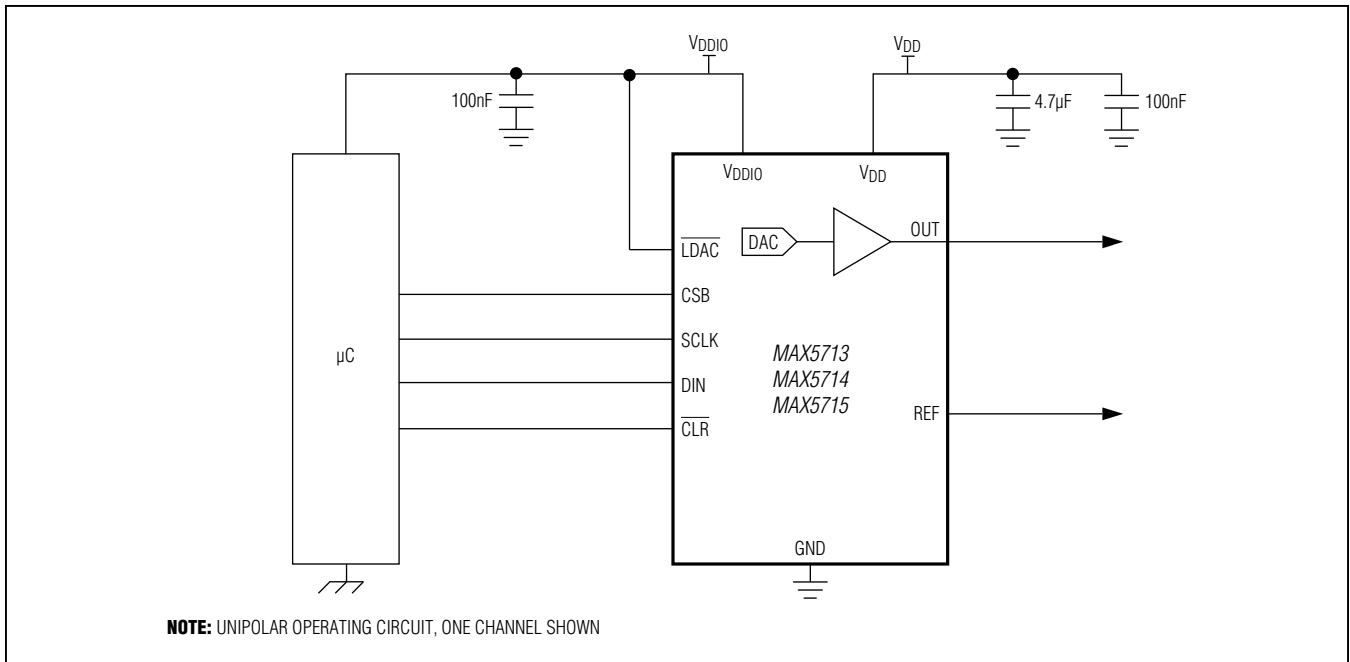
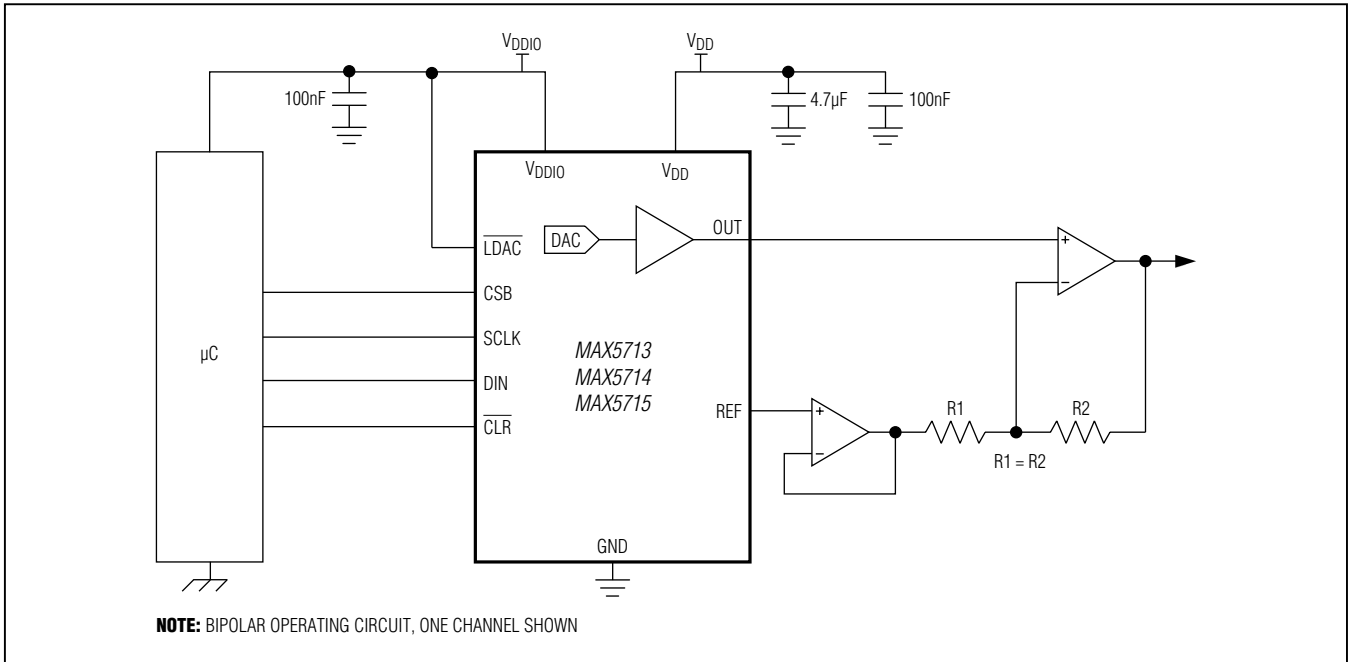

# MAX5713/MAX5714/MAX5715

## Ultra-Small, Quad-Channel, 8-/10-/12-Bit Buffered Output DACs with Internal Reference and SPI Interface

### Ordering Information

PART	PIN-PACKAGE	RESOLUTION (BIT)	INTERNAL REFERENCE TEMPCO (ppm/°C)
MAX5713AUD+T*	14 TSSOP	8	10 (typ)
MAX5714AUD+T*	14 TSSOP	10	10 (typ)
MAX5715AAUD+T	14 TSSOP	12	3 (typ), 10 (max)
MAX5715BAUD+T*	14 TSSOP	12	10 (typ)
MAX5715AWC+T	12 WLP	12	3 (typ), 10 (max)

**Note:** All devices are specified over the -40°C to +125°C temperature range.

+Denotes a lead(Pb)-free/RoHS-compliant package.

T = Tape and reel.

\*Future product—Contact factory for availability.

### Chip Information

PROCESS: BiCMOS

### Package Information

For the latest package outline information and land patterns (footprints), go to [www.maximintegrated.com/packages](http://www.maximintegrated.com/packages). Note that a "+", "#", or "-" in the package code indicates RoHS status only. Package drawings may show a different suffix character, but the drawing pertains to the package regardless of RoHS status.

PACKAGE TYPE	PACKAGE CODE	OUTLINE NO.	LAND PATTERN NO.
14 TSSOP	U14+1	<a href="#">21-0066</a>	<a href="#">90-0113</a>
12 WLP	W121B2+1	<a href="#">21-0009</a>	Refer to <a href="#">Application Note 1891</a>

# MAX5713/MAX5714/MAX5715

## Ultra-Small, Quad-Channel, 8-/10-/12-Bit Buffered Output DACs with Internal Reference and SPI Interface

### Revision History

REVISION NUMBER	REVISION DATE	DESCRIPTION	PAGES CHANGED
0	7/12	Initial release	—
1	11/12	Updated the <i>Electrical Characteristics</i> , <i>Typical Operating Characteristics</i> , <i>Typical Operating Characteristics</i> , and the <i>Ordering Information</i> .	5, 7, 9, 10, 12, 13, 25, 26
2	1/13	Updated the <i>Electrical Characteristics</i> and the <i>Ordering Information</i> .	7, 26



Maxim Integrated cannot assume responsibility for use of any circuitry other than circuitry entirely embodied in a Maxim Integrated product. No circuit patent licenses are implied. Maxim Integrated reserves the right to change the circuitry and specifications without notice at any time. The parametric values (min and max limits) shown in the Electrical Characteristics table are guaranteed. Other parametric values quoted in this data sheet are provided for guidance.

**Maxim Integrated 160 Rio Robles, San Jose, CA 95134 USA 1-408-601-1000**

27



Компания «ЭлектроПласт» предлагает заключение долгосрочных отношений при поставках импортных электронных компонентов на взаимовыгодных условиях!

Наши преимущества:

- Оперативные поставки широкого спектра электронных компонентов отечественного и импортного производства напрямую от производителей и с крупнейших мировых складов;
- Поставка более 17-ти миллионов наименований электронных компонентов;
- Поставка сложных, дефицитных, либо снятых с производства позиций;
- Оперативные сроки поставки под заказ (от 5 рабочих дней);
- Экспресс доставка в любую точку России;
- Техническая поддержка проекта, помощь в подборе аналогов, поставка прототипов;
- Система менеджмента качества сертифицирована по Международному стандарту ISO 9001;
- Лицензия ФСБ на осуществление работ с использованием сведений, составляющих государственную тайну;
- Поставка специализированных компонентов (Xilinx, Altera, Analog Devices, Intersil, Interpoint, Microsemi, Aeroflex, Peregrine, Syfer, Eurofarad, Texas Instrument, Miteq, Cobham, E2V, MA-COM, Hittite, Mini-Circuits, General Dynamics и др.);

Помимо этого, одним из направлений компании «ЭлектроПласт» является направление «Источники питания». Мы предлагаем Вам помощь Конструкторского отдела:

- Подбор оптимального решения, техническое обоснование при выборе компонента;
- Подбор аналогов;
- Консультации по применению компонента;
- Поставка образцов и прототипов;
- Техническая поддержка проекта;
- Защита от снятия компонента с производства.



#### Как с нами связаться

**Телефон:** 8 (812) 309 58 32 (многоканальный)

**Факс:** 8 (812) 320-02-42

**Электронная почта:** [org@eplast1.ru](mailto:org@eplast1.ru)

**Адрес:** 198099, г. Санкт-Петербург, ул. Калинина, дом 2, корпус 4, литера А.