



The engineer's choice

ebmpapst

4416 M

INDEX

1	General	3
2	Mechanics	3
2.1	General	3
2.2	Connections	3
3	Operating Data	4
3.1	Operating Data - Electrical Interface - Input	4
3.2	Electrical Operating Data	5
3.3	Operating Data - Electrical Interface -Output	5
3.4	Electrical Features	6
3.5	Aerodynamic	7
3.6	Sound Data	8
4	Environment	8
4.1	General	8
4.2	Climatic requirements*)	8
5	Safety	9
5.1	Electrical Safety	9
5.2	Approval Tests	9
6	Reliability	9
6.1	General	9

1 General

Fan type	Fan	
Rotational direction looking at rotor	clockwise	
Airflow direction	Air outlet over struts	
Bearing system	Ball bearing	
Mounting position	any	

2 Mechanics

2.1 General

Width	119,0 mm	
Height	119,0 mm	
Depth	38,0 mm	
Weight	0,270 kg	
Housing material	Plastic	
Impeller material	Plastic	
Max. torque when mounted across both mounting flanges	wire outlet corner: 80 Ncm remaining corners: 80 Ncm	
Screw size	ISO 4762 - M4 degreased, without an additional brace and without washer	

2.2 Connections

Electrical connection	Wires	
Length of lead wire	310 mm	
Tolerance	+/- 10,0 mm	
Wire gauge (AWG)	24	
Insulation diameter	1,10 mm	

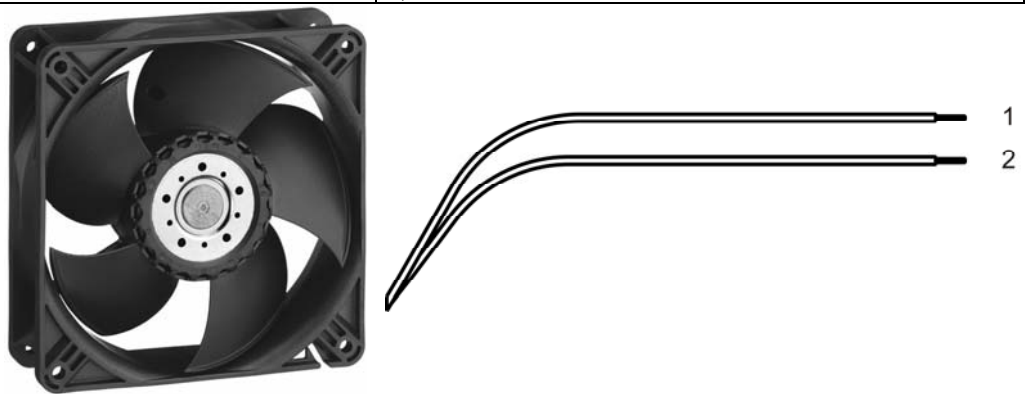

	Colour	Operation
Wire 1	red	+ UB
Wire 2	blue	- GND

3 Operating Data

3.1 Operating Data - Electrical Interface - Input

Control input	None
---------------	------

3.2 Electrical Operating Data

Measurement conditions: Normal air density = 1,2 kg/m³; Temperature 23°C +/- 3°C; Motor axis horizontal; warm-up time before measuring 5 minutes (unless otherwise specified). In the intake and outlet area should not be any solid obstruction within 0,5 m.

$\Delta p = 0$: corresp. to free air flow (see section 3.5)
I: corresp. to arithm. mean current value

Features	Condition	Symbol	Values		
Voltage range	$\Delta p = 0$	U	30,0 V		45,0 V
Nominal voltage	$\Delta p = 0$	U_N		36,0 V	
Power consumption	$\Delta p = 0$	P	2,9 W	4,2 W	6,8 W
Tolerance	0001		+/- 17,5 %	+/- 12,5 %	+/- 15,0 %
Current consumption	$\Delta p = 0$	I	97 mA	116 mA	151 mA
Tolerance	0001		+/- 17,5 %	+/- 12,5 %	+/- 15,0 %
Speed	$\Delta p = 0$	n	2.850 1/min	3.300 1/min	4.000 1/min
Tolerance	0001		+/- 12,5 %	+/- 7,5 %	+/- 10,0 %
Inrush current				740 mA	

3.3 Operating Data - Electrical Interface -Output

Tacho type	None
------------	------

Alarm type	None
------------	------

3.4 Electrical Features

Electronic function	None	
Reversed polarity protection	Rectifying diode	
Max. residual current at U_n	$I_F < 500 \mu A$	
Locked rotor protection	Auto restart	
Locked rotor current at U_n	approx. 740 mA	
Clock signal t_3/t_4 at locked rotor	Typical: 0,4 s / 10 s	

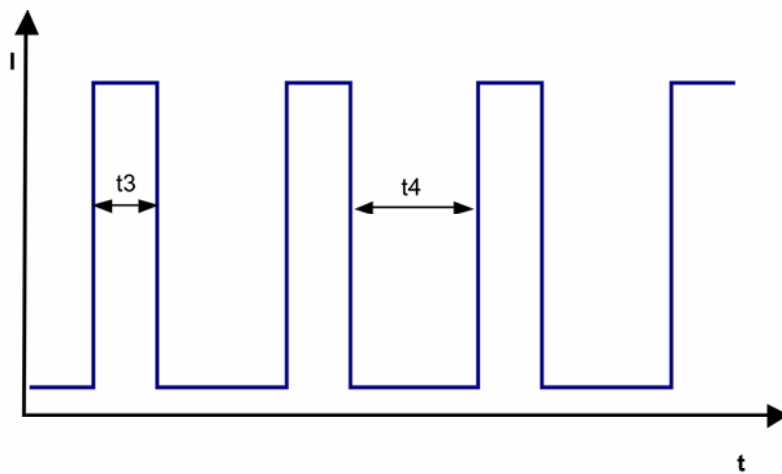

3.5 Aerodynamic

Measurement conditions: Measured with a double chamber intake rig acc. to DIN EN ISO 5801.
 Normal air density = 1,2 kg/m³; Temperature 23°C +/- 3°C;
 In the intake and outlet area should not be any solid obstruction within 0,5 m.

a.) Operation condition:

3.300 1/min at free air flow		
Max. free-air flow ($\Delta p = 0 / \dot{V} = \text{max.}$)	184,0 m ³ /h	
Max. static pressure ($\Delta p = \text{max.} / \dot{V} = 0$)	103 Pa	

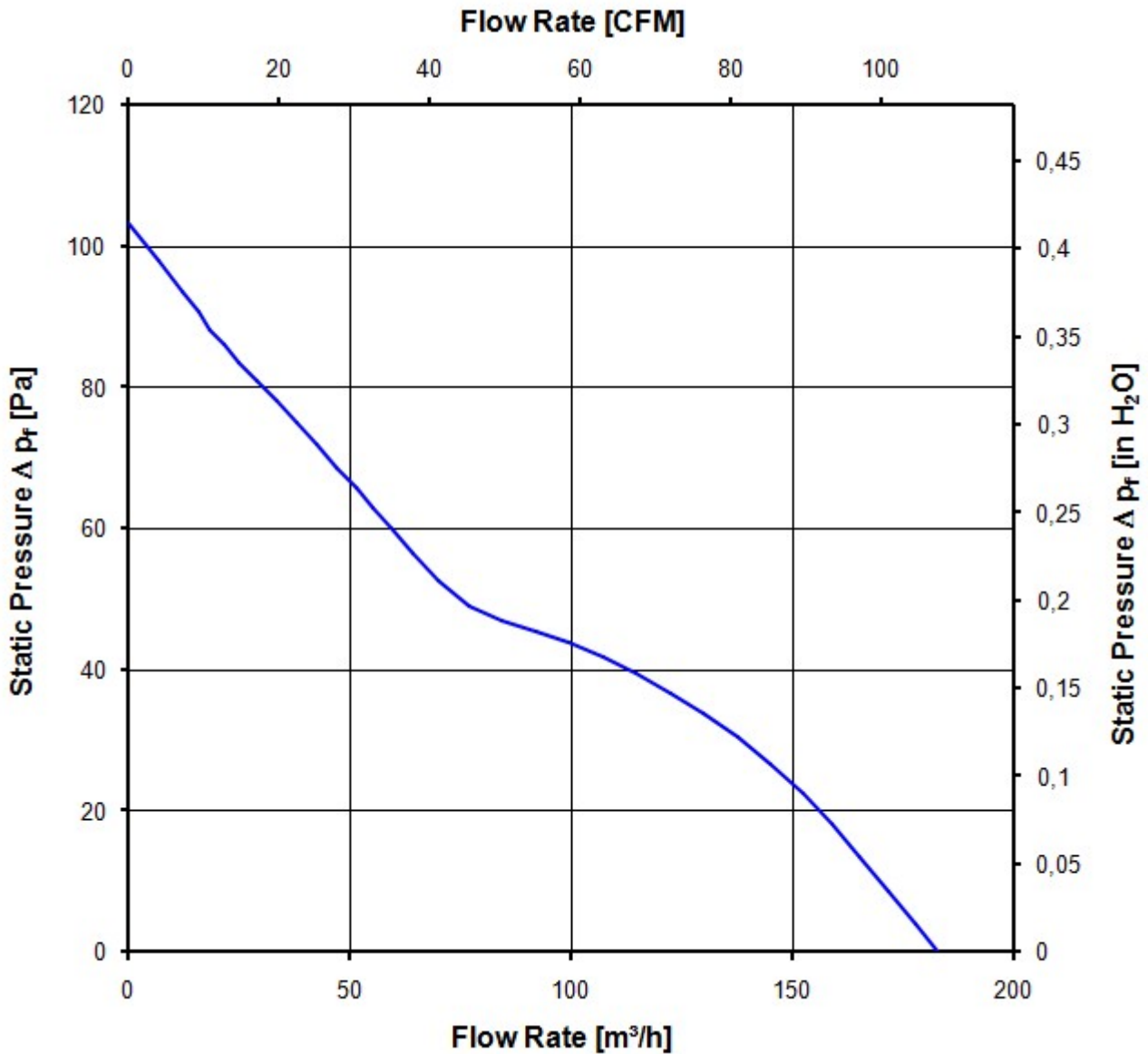

3.6 Sound Data

Measurement conditions: Sound pressure level: 1 Meter distance between microphone and the air intake.
 Sound power level: Acc. to DIN 45635 part 38 (ISO 10302)
 Measured in a semianchoic chamber with a background noise level of $L_p(A) < 5 \text{ dB(A)}$
 For further measurement conditions see section 3.5

a.) Operation condition:

3.300 1/min at free air flow		
Optimal operating point	106,0 m ³ /h @ 38 Pa	
Sound power level at the optimal operating point	5,3 bel(A)	
Sound pressure level at free air flow, measured in rubber bands	43,0 dB(A)	

4 Environment

4.1 General

Min. permitted ambient temperature TU min.	-20 °C	
Max. permitted ambient temperature TU max.	70 °C	
Min. permitted storage temperature TL min.	-40 °C	
Max. permitted storage temperature TL max.	80 °C	

4.2 Climatic requirements*)

Humidity requirements	humid heat, constant; according to DIN EN 60068-2-78, 14 days	
Water exposure	None	
Radiation exposure	None	
Dust requirements	None	
Salt fog requirements	None	
Harmful gas requirements	None	

*) Permitted application area:

The product is intended for use in sheltered rooms with controlled temperature and controlled humidity. Directly exposure to water must be avoided.

Pollution degree 1 (according DIN EN 60664-1)

There is either no pollution or it occurs only dry, non-conductive pollution. The pollution has no negative impact.

5 Safety

5.1 Electrical Safety

Dielectric strength DIN EN 60950 (VDE 0805) and DIN EN 60335 (VDE 0700) A.) Type test Measuring conditions: After 48h of storage at 95% R.H. and 25°C. No arcing or breakdown is allowed! All connections together to ground.	500 VAC / 1 Min.	
B.) Routine test Measuring conditions: At indoor climate. No arcing or breakdown is allowed! All connections together to ground.	500 VAC / 1 Sec.	
Isolation resistance Measuring conditions: After 48h of storage at 95% R.H. and 25°C measured with U=500 VDC for 1 min.	RI > 10 MOhm	
Air and leakage distances	1,0 mm / 1,2 mm	
Protection class	III	

5.2 Approval Tests

UL	Yes / UL507, Electric Fans
CSA	Yes

The approval tests are observed to:

Maximal permitted operating voltage (see section 3.1) and max. permitted ambient temperature TU max.

6 Reliability

6.1 General

Life expectancy L10 at TU = 40 °C	65.000 h	
Life expectancy L10 at TU max.	32.500 h	
Life expectancy L10 Delta (40 °C)	130.000 h	

Quality of this document, and clarity of values and the use or consideration of this document, does not constitute a warranty or liability for the manufacturer. It is the user's responsibility to ensure that the use of this document is in accordance with the applicable laws and regulations.

Informationen zum 3D-Modell (Modell-ID: 9283510500) finden Sie unter: www.ebmpapst.com

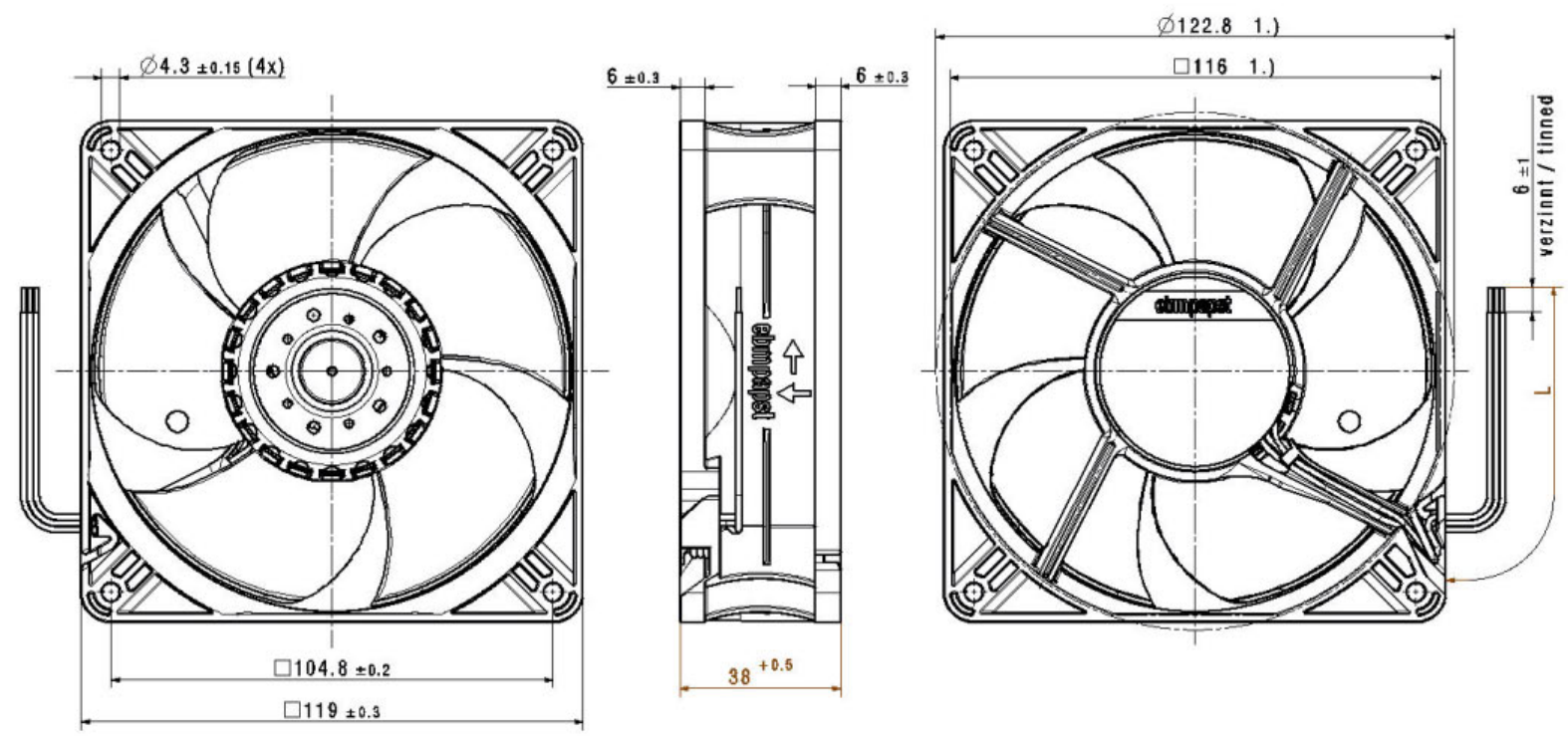

Zeichnung entspricht 3D-Modell:
 Drawing is equivalent to 3D-Model:
 9283510500_CPA_000_A

- A**
- 1.) Maße fuer Montageausschnitt
 - max. Anziehdrehmoment = 0.8Nm
 - Axialspiel: mit Feder spielfrei verspannt
 - Anzahl und Länge der Litzen siehe BV- Bl. 1
- A**
- 1.) measures for mounting cut-out
 - max. tightening torque = 0.8Nm
 - without axial clearance by a pre-loaded spring
 - length and number of wires see design specification page 1

MP-Status/Date 	DWG-Verf./ Drawing-Verf.	DWG-Gezeichnet/ DWG-Gezeichnet	DWG-Geprüft/ DWG-Geprüft	Material / Material: Volume / Volumen (m³): Masse / Mass (g):
Toleranzang. / Tolerances: Allg. Toleranzklasse / allg. Toleranzklasse	Datum Name Bearb./ Drawn: Gepr./ Checked: Freigegeben/ Released:	Artikel / Title: Züg.-Nr. / Drawing No.: Dr.-F.Zugl. / Revision:	ebmpapst ebm-papst st.-georgien GmbH & Co KG	Zeichn.-Typ / Type of Drawing: Teil-Anzahl / Part (1/1) (1/1): Zeichn. / Drawing: Format / Size: Blattzahl/Blätter / 2/1



Компания «ЭлектроПласт» предлагает заключение долгосрочных отношений при поставках импортных электронных компонентов на взаимовыгодных условиях!

Наши преимущества:

- Оперативные поставки широкого спектра электронных компонентов отечественного и импортного производства напрямую от производителей и с крупнейших мировых складов;
- Поставка более 17-ти миллионов наименований электронных компонентов;
- Поставка сложных, дефицитных, либо снятых с производства позиций;
- Оперативные сроки поставки под заказ (от 5 рабочих дней);
- Экспресс доставка в любую точку России;
- Техническая поддержка проекта, помощь в подборе аналогов, поставка прототипов;
- Система менеджмента качества сертифицирована по Международному стандарту ISO 9001;
- Лицензия ФСБ на осуществление работ с использованием сведений, составляющих государственную тайну;
- Поставка специализированных компонентов (Xilinx, Altera, Analog Devices, Intersil, Interpoint, Microsemi, Aeroflex, Peregrine, Syfer, Eurofarad, Texas Instrument, Miteq, Cobham, E2V, MA-COM, Hittite, Mini-Circuits, General Dynamics и др.);

Помимо этого, одним из направлений компании «ЭлектроПласт» является направление «Источники питания». Мы предлагаем Вам помощь Конструкторского отдела:

- Подбор оптимального решения, техническое обоснование при выборе компонента;
- Подбор аналогов;
- Консультации по применению компонента;
- Поставка образцов и прототипов;
- Техническая поддержка проекта;
- Защита от снятия компонента с производства.



Как с нами связаться

Телефон: 8 (812) 309 58 32 (многоканальный)

Факс: 8 (812) 320-02-42

Электронная почта: org@eplast1.ru

Адрес: 198099, г. Санкт-Петербург, ул. Калинина, дом 2, корпус 4, литера А.