

THIS DRAWING IS UNPUBLISHED. RELEASED FOR PUBLICATION 20
 © COPYRIGHT 20 BY - ALL RIGHTS RESERVED.

REVISIONS				
P	LTR	DESCRIPTION	DATE	APVD
A		INITIAL RELEASE	22JUN2015	DL CW
AI		ECR-17-018760	29DEC2017	CH CW

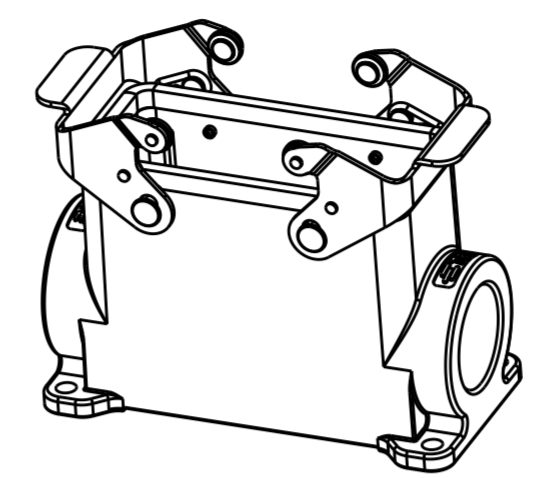
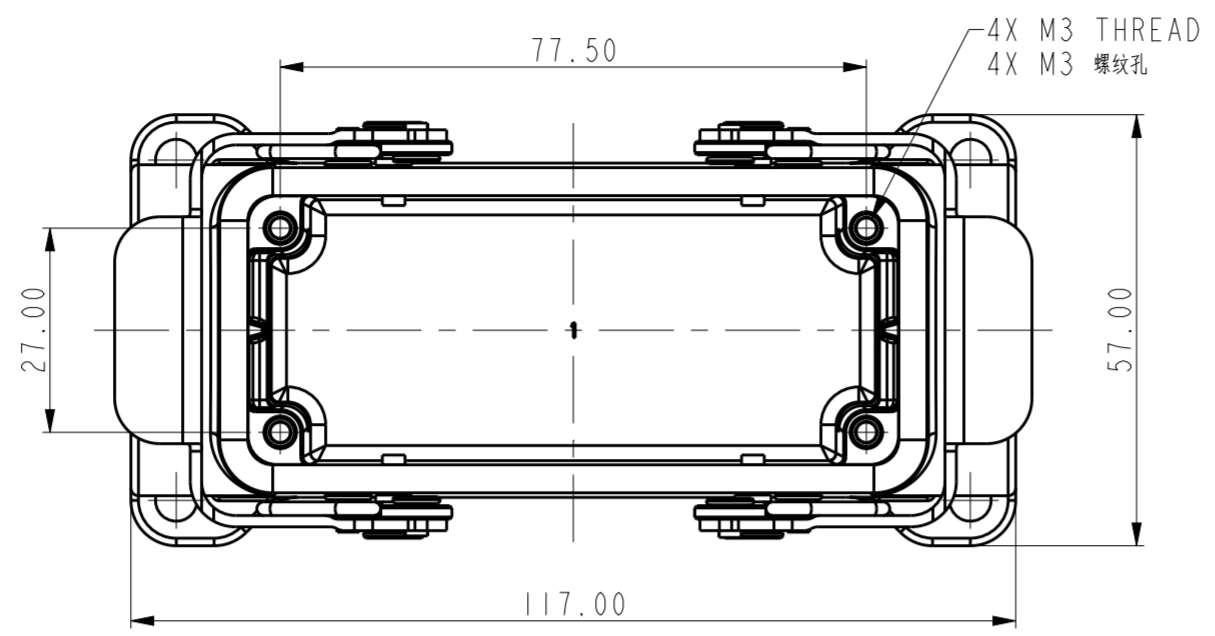

SCALE 1:2

NOTES:
 1. TECHNICAL CHARACTERISTICS:
 HOUSING MATERIAL: DIE CAST ALUMINIUM ALLOY
 SURFACE TREATMENT: POWDER COATED, GREY
 DEGREE OF PROTECTION: IP65 (MATED)

注释:
 1. 技术参数:
 主体材料: 铝合金
 表面处理: 灰色粉末喷涂
 防护等级: IP65(配合)

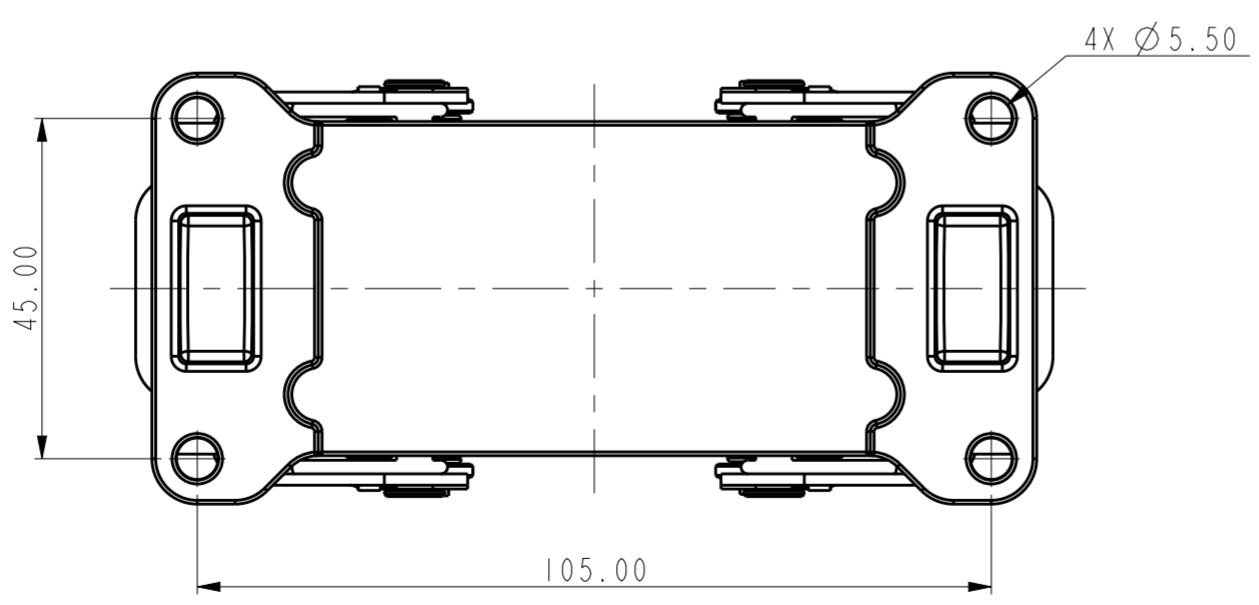
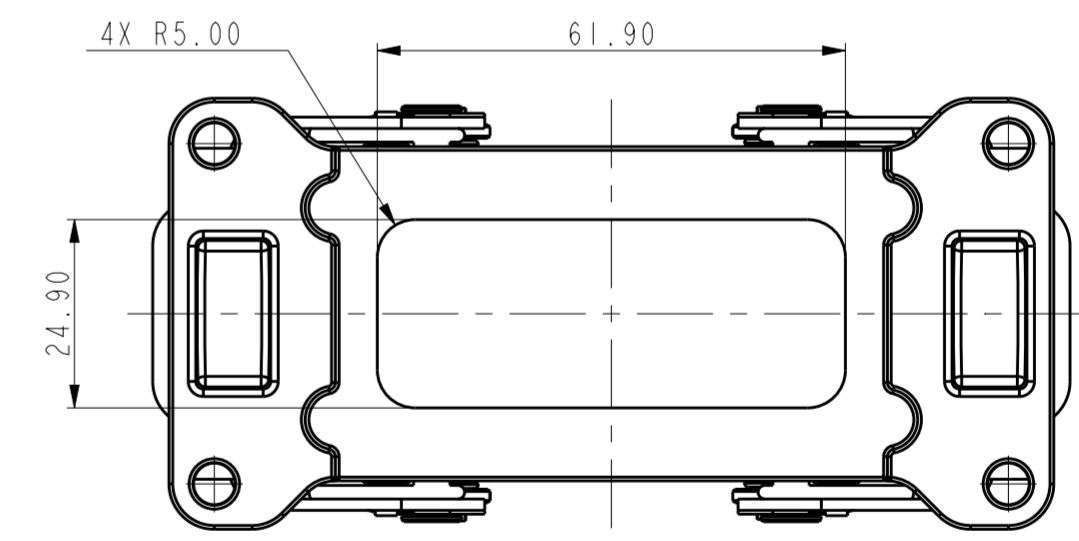
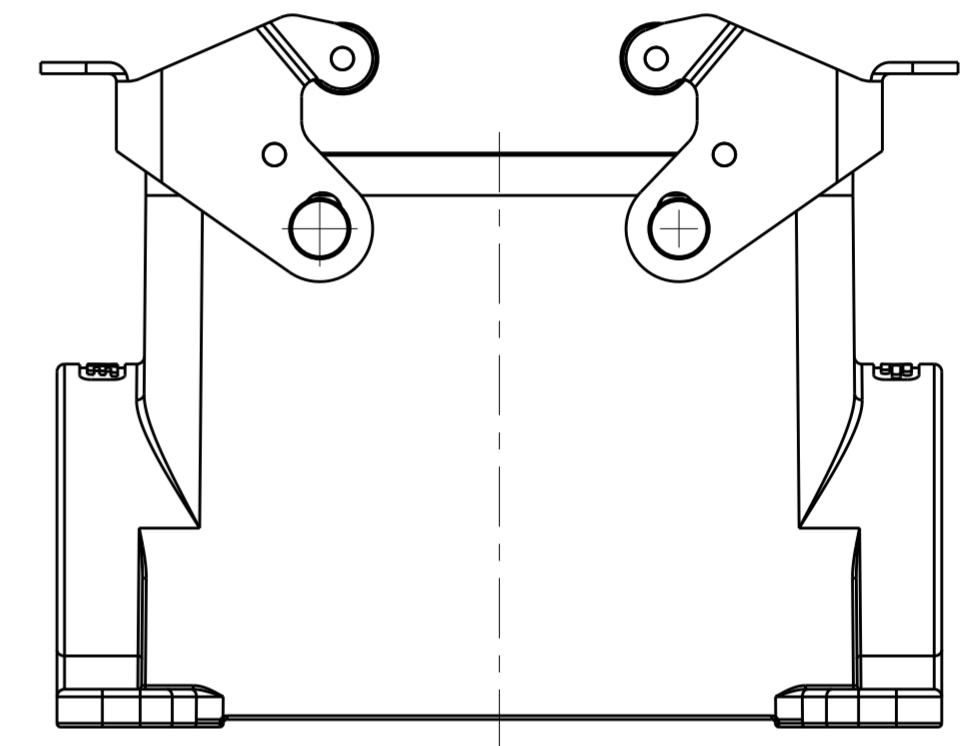
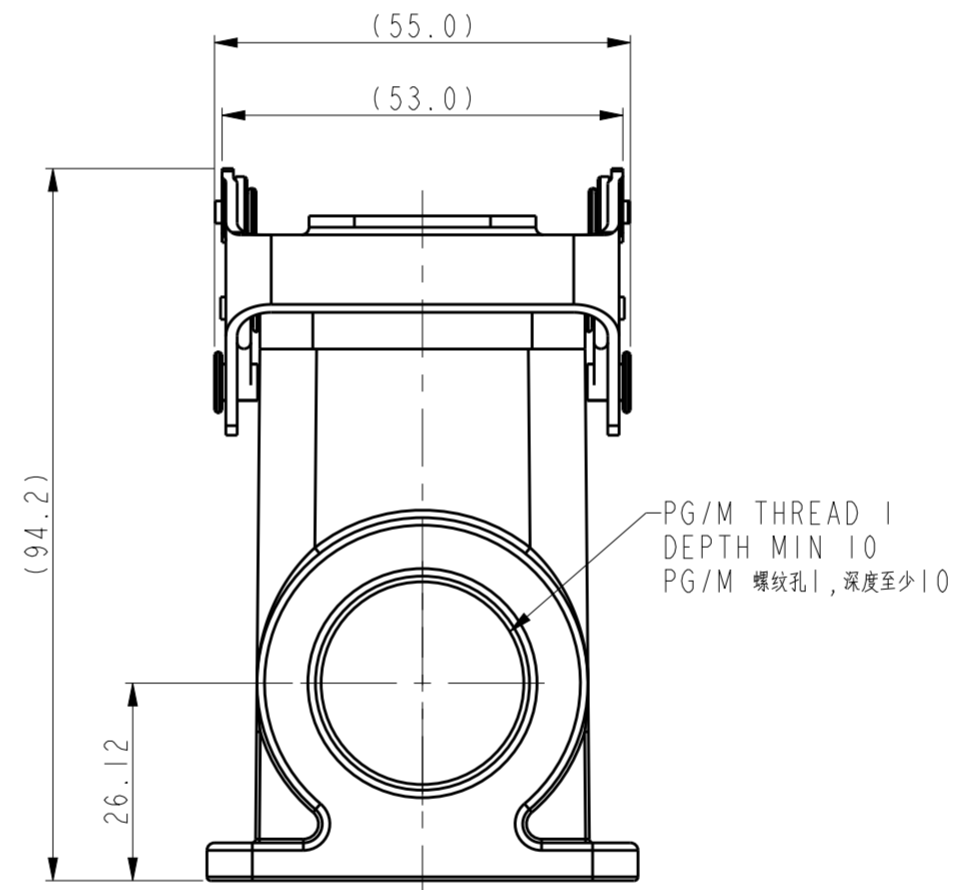
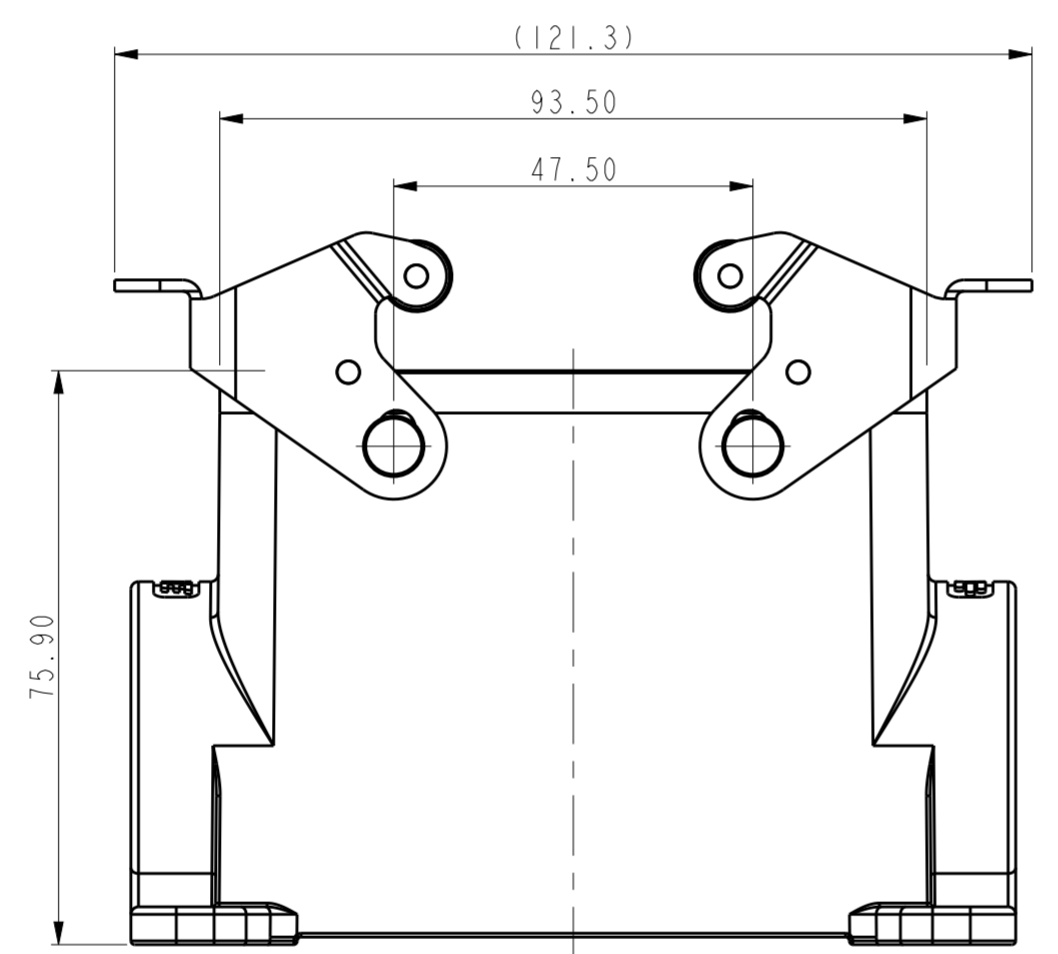
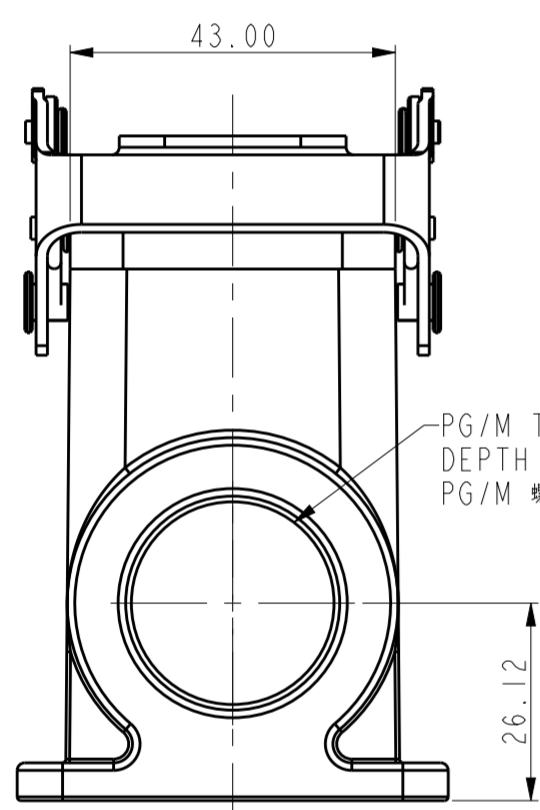

TYPE 1: HIGH CONSTRUCTION + STAINLESS STEEL
 DOUBLE LOCKING, SIDE ENTRY
 类型1: 高结构+不锈钢双扣, 侧出

TYPE 2: HIGH CONSTRUCTION + STAINLESS STEEL
 DOUBLE LOCKING, SIDE ENTRY + BOTTOM CUT OUT,
 OTHER SPEC REFER TO TYPE 1.
 类型2: 高结构+不锈钢双扣, 侧出+底部开孔, 其它参照类型1.

THIS DRAWING IS A CONTROLLED DOCUMENT.		DWN DAVID.LI 22JUN2015	TE Connectivity	
		CHK CHRIS.WANG 22JUN2015		
		APVD XIANG.XU 22JUN2015	NAME HI6B-SGRHS-PG/M	
DIMENSIONS: mm		PRODUCT SPEC 108-137013	SIZE A2	
TOLERANCES UNLESS OTHERWISE SPECIFIED:		APPLICATION SPEC 114-137013	CAGE CODE -	
0 PLC ±		WEIGHT -	DRAWING NO. C-TI47016XXXX000	
1 PLC ±		CUSTOMER DRAWING	RESTRICTED TO -	
2 PLC ±		SCALE 1:1	SHEET 1 OF 3	
3 PLC ±			REV AI	
4 PLC ±				
ANGLES ±				
FINISH -				

THIS DRAWING IS UNPUBLISHED. RELEASED FOR PUBLICATION 20
 © COPYRIGHT 20 BY - ALL RIGHTS RESERVED.

REVISIONS				
P	LTR	DESCRIPTION	DATE	APVD
-		SEE SHEET 1	-	-

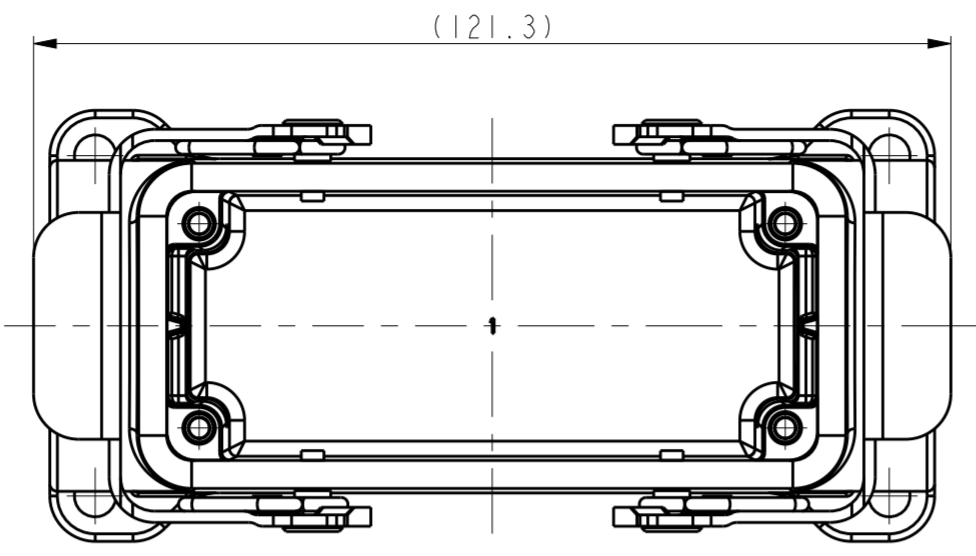

NOTES:
SEE SHEET 1

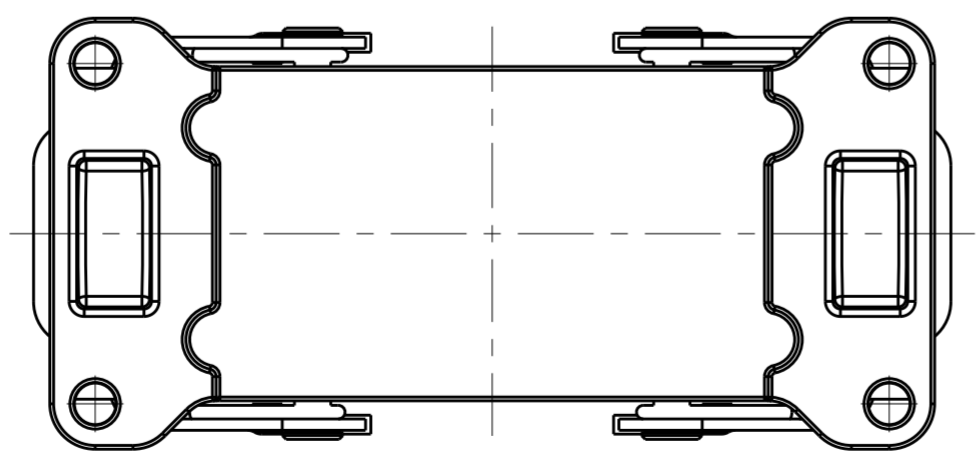
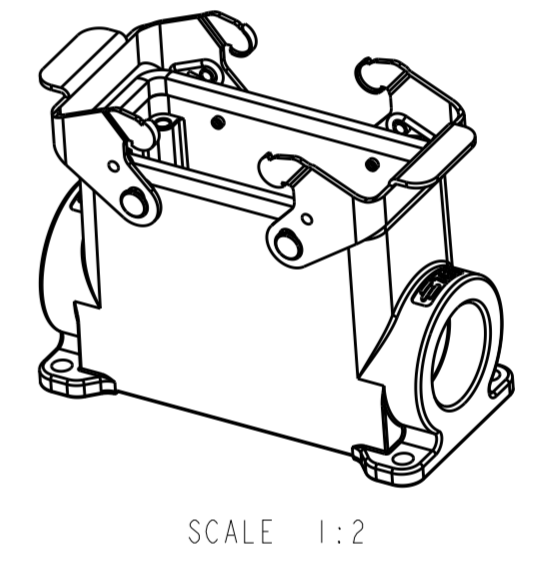
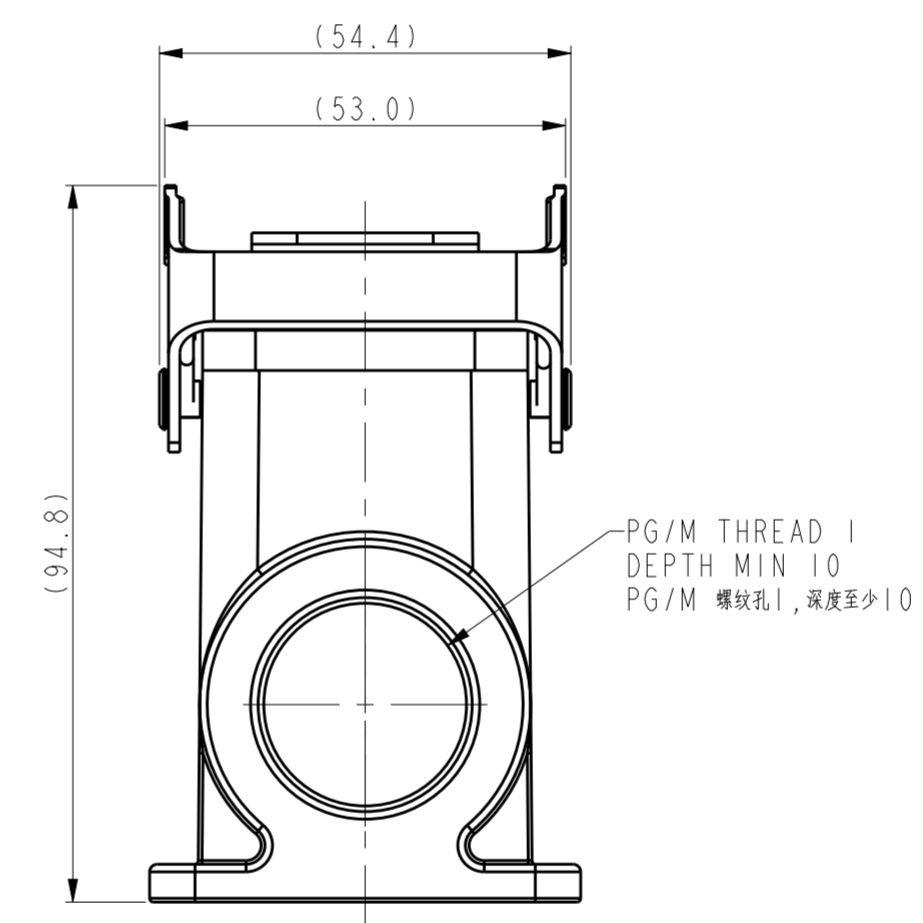
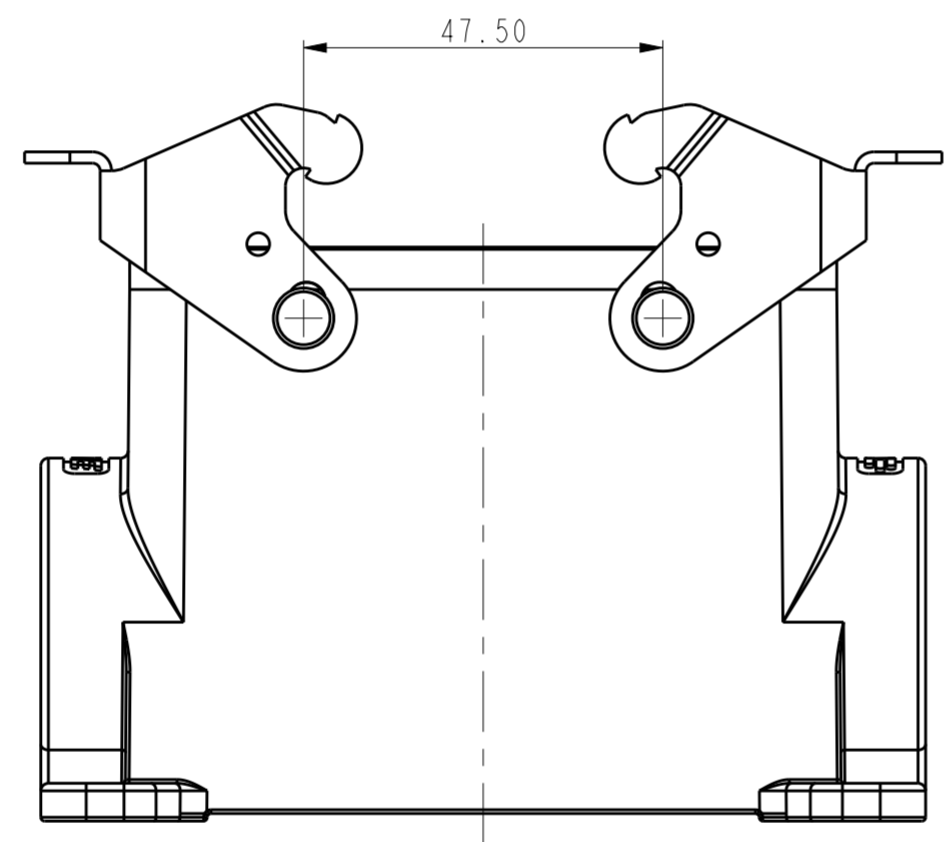
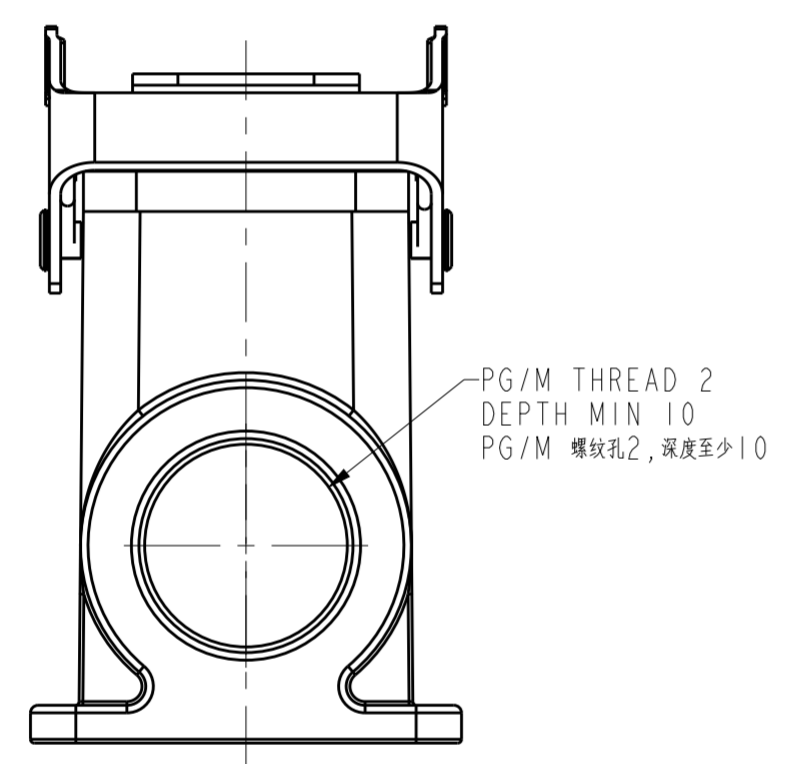

TYPE 3: HIGH CONSTRUCTION + METAL DOUBLE LOCKING, SIDE ENTRY, OTHER SPEC REFER TO TYPE 1.
 类型3: 高结构+彩锌双扣, 侧出, 其它参照类型1.

THIS DRAWING IS A CONTROLLED DOCUMENT.		DWN DAVID.LI 22JUN2015	STE TE Connectivity	
		CHK CHRIS.WANG 22JUN2015		
		APVD XIANG.XU 22JUN2015	NAME HI6B-SGRHS-PG/M	
DIMENSIONS: mm		PRODUCT SPEC 108-137013	SIZE A2	
TOLERANCES UNLESS OTHERWISE SPECIFIED:		APPLICATION SPEC 114-137013	CAGE CODE -	
0 PLC ±	1 PLC ±	WEIGHT -	DRAWING NO. C-TI47016XXXX000	
2 PLC ±	3 PLC ±	CUSTOMER DRAWING	RESTRICTED TO -	
4 PLC ±	ANGLES ±	SCALE 1:2	SHEET 2 OF 3	
FINISH -	-		REV A1	

THIS DRAWING IS UNPUBLISHED. RELEASED FOR PUBLICATION 20
 © COPYRIGHT 20 BY - ALL RIGHTS RESERVED.

REVISIONS				
P	LTR	DESCRIPTION	DATE	APVD
-		SEE SHEET 1	-	-

NOTES:
SEE SHEET 1

PART NUMBER 料号	PART DESCRIPTION 描述	PG/M THREAD 1 PG/M 螺纹孔1	PG/M THREAD 2 PG/M 螺纹孔2	TYPE 类型
TI470162232-000	HI6B-SGRH-2M32 HI6B HOUSING, SURFACE MOUNTED, METAL DOUBLE LOCKING, 2M32, HIGH CONSTRUCTION, POWDER COATED, GREY HI6B下壳, 表面安装, 彩钢双扣, 2M32, 高结构, 灰色粉末喷涂	M32	M32	TYPE 3 类型 3
TI470162229-000	HI6B-SGRH-2PG29 HI6B HOUSING, SURFACE MOUNTED, METAL DOUBLE LOCKING, 2PG29, HIGH CONSTRUCTION, POWDER COATED, GREY HI6B下壳, 表面安装, 彩钢双扣, 2PG29, 高结构, 灰色粉末喷涂	PG29	PG29	
TI470162225-000	HI6B-SGRH-2M25 HI6B HOUSING, SURFACE MOUNTED, METAL DOUBLE LOCKING, 2M25, HIGH CONSTRUCTION, POWDER COATED, GREY HI6B下壳, 表面安装, 彩钢双扣, 2M25, 高结构, 灰色粉末喷涂	M25	M25	
TI470162221-000	HI6B-SGRH-2PG21 HI6B HOUSING, SURFACE MOUNTED, METAL DOUBLE LOCKING, 2PG21, HIGH CONSTRUCTION, POWDER COATED, GREY HI6B下壳, 表面安装, 彩钢双扣, 2PG21, 高结构, 灰色粉末喷涂	PG21	PG21	
TI470162132-000	HI6B-SGRH-M32 HI6B HOUSING, SURFACE MOUNTED, METAL DOUBLE LOCKING, M32, HIGH CONSTRUCTION, POWDER COATED, GREY HI6B下壳, 表面安装, 彩钢双扣, M32, 高结构, 灰色粉末喷涂	M32	-	
TI470162129-000	HI6B-SGRH-PG29 HI6B HOUSING, SURFACE MOUNTED, METAL DOUBLE LOCKING, PG29, HIGH CONSTRUCTION, POWDER COATED, GREY HI6B下壳, 表面安装, 彩钢双扣, PG29, 高结构, 灰色粉末喷涂	PG29	-	
TI470162125-000	HI6B-SGRH-M25 HI6B HOUSING, SURFACE MOUNTED, METAL DOUBLE LOCKING, M25, HIGH CONSTRUCTION, POWDER COATED, GREY HI6B下壳, 表面安装, 彩钢双扣, M25, 高结构, 灰色粉末喷涂	M25	-	
TI470162121-000	HI6B-SGRH-PG21 HI6B HOUSING, SURFACE MOUNTED, METAL DOUBLE LOCKING, PG21, HIGH CONSTRUCTION, POWDER COATED, GREY HI6B下壳, 表面安装, 彩钢双扣, PG21, 高结构, 灰色粉末喷涂	PG21	-	TYPE 2 类型2
TI470165121-000	HI6B-SGRHS-PG21 HI6B HOUSING, SURFACE MOUNTED, STAINLESS STEEL DOUBLE LOCKING, PG21, HIGH CONSTRUCTION, MILL ON BOTTOM, POWDER COATED, GREY HI6B下壳, 表面安装, 不锈钢双扣, PG21, 高结构, 底部铣槽, 灰色粉末喷涂	PG21	-	
TI470161232-000	HI6B-SGRHS-2M32 HI6B HOUSING, SURFACE MOUNTED, STAINLESS STEEL DOUBLE LOCKING, 2M32, HIGH CONSTRUCTION, POWDER COATED, GREY HI6B下壳, 表面安装, 不锈钢双扣, 2M32, 高结构, 灰色粉末喷涂	M32	M32	TYPE 1 类型1
TI470161229-000	HI6B-SGRHS-2PG29 HI6B HOUSING, SURFACE MOUNTED, STAINLESS STEEL DOUBLE LOCKING, 2PG29, HIGH CONSTRUCTION, POWDER COATED, GREY HI6B下壳, 表面安装, 不锈钢双扣, 2PG29, 高结构, 灰色粉末喷涂	PG29	PG29	
TI470161221-000	HI6B-SGRHS-2PG21 HI6B HOUSING, SURFACE MOUNTED, STAINLESS STEEL DOUBLE LOCKING, 2PG21, HIGH CONSTRUCTION, POWDER COATED, GREY HI6B下壳, 表面安装, 不锈钢双扣, 2PG21, 高结构, 灰色粉末喷涂	PG21	PG21	
TI470161140-000	HI6B-SGRHS-M40 HI6B HOUSING, SURFACE MOUNTED, STAINLESS STEEL DOUBLE LOCKING, M40, HIGH CONSTRUCTION, POWDER COATED, GREY HI6B下壳, 表面安装, 不锈钢双扣, M40, 高结构, 灰色粉末喷涂	M40	-	
TI470161132-000	HI6B-SGRHS-M32 HI6B HOUSING, SURFACE MOUNTED, STAINLESS STEEL DOUBLE LOCKING, M32, HIGH CONSTRUCTION, POWDER COATED, GREY HI6B下壳, 表面安装, 不锈钢双扣, M32, 高结构, 灰色粉末喷涂	M32	-	
TI470161129-000	HI6B-SGRHS-PG29 HI6B HOUSING, SURFACE MOUNTED, STAINLESS STEEL DOUBLE LOCKING, PG29, HIGH CONSTRUCTION, POWDER COATED, GREY HI6B下壳, 表面安装, 不锈钢双扣, PG29, 高结构, 灰色粉末喷涂	PG29	-	
TI470161121-000	HI6B-SGRHS-PG21 HI6B HOUSING, SURFACE MOUNTED, STAINLESS STEEL DOUBLE LOCKING, PG21, HIGH CONSTRUCTION, POWDER COATED, GREY HI6B下壳, 表面安装, 不锈钢双扣, PG21, 高结构, 灰色粉末喷涂	PG21	-	
TI470160000-000	HI6B-SGRHS-T HI6B HOUSING, SURFACE MOUNTED, STAINLESS STEEL DOUBLE LOCKING, NO ENTRY, HIGH CONSTRUCTION, POWDER COATED, GREY HI6B下壳, 表面安装, 不锈钢双扣, 不开孔, 高结构, 灰色粉末喷涂	-	-	

THIS DRAWING IS A CONTROLLED DOCUMENT.		DWN DAVID.LI 22 JUN 2015	STE TE Connectivity	
		CHK CHRIS.WANG 22 JUN 2015		
DIMENSIONS: mm		APVD XIANG.XU 22 JUN 2015	NAME HI6B-SGRHS-PG/M	
TOLERANCES UNLESS OTHERWISE SPECIFIED:		PRODUCT SPEC 108-137013	RESTRICTED TO	
0 PLC ±-		APPLICATION SPEC 114-137013	SIZE A2	CAGE CODE -
1 PLC ±-		WEIGHT -	DRAWING NO. C-TI47016XXXX000	
2 PLC ±-		CUSTOMER DRAWING	SCALE 1:1	SHEET 3 OF 3
3 PLC ±-				REV A1
4 PLC ±-				
ANGLES ±-				
FINISH -				
MATERIAL -				



Компания «ЭлектроПласт» предлагает заключение долгосрочных отношений при поставках импортных электронных компонентов на взаимовыгодных условиях!

Наши преимущества:

- Оперативные поставки широкого спектра электронных компонентов отечественного и импортного производства напрямую от производителей и с крупнейших мировых складов;
- Поставка более 17-ти миллионов наименований электронных компонентов;
- Поставка сложных, дефицитных, либо снятых с производства позиций;
- Оперативные сроки поставки под заказ (от 5 рабочих дней);
- Экспресс доставка в любую точку России;
- Техническая поддержка проекта, помощь в подборе аналогов, поставка прототипов;
- Система менеджмента качества сертифицирована по Международному стандарту ISO 9001;
- Лицензия ФСБ на осуществление работ с использованием сведений, составляющих государственную тайну;
- Поставка специализированных компонентов (Xilinx, Altera, Analog Devices, Intersil, Interpoint, Microsemi, Aeroflex, Peregrine, Syfer, Eurofarad, Texas Instrument, Miteq, Cobham, E2V, MA-COM, Hittite, Mini-Circuits, General Dynamics и др.);

Помимо этого, одним из направлений компании «ЭлектроПласт» является направление «Источники питания». Мы предлагаем Вам помощь Конструкторского отдела:

- Подбор оптимального решения, техническое обоснование при выборе компонента;
- Подбор аналогов;
- Консультации по применению компонента;
- Поставка образцов и прототипов;
- Техническая поддержка проекта;
- Защита от снятия компонента с производства.



Как с нами связаться

Телефон: 8 (812) 309 58 32 (многоканальный)

Факс: 8 (812) 320-02-42

Электронная почта: org@eplast1.ru

Адрес: 198099, г. Санкт-Петербург, ул. Калинина, дом 2, корпус 4, литера А.