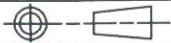

HIGH DENSITY YHLZ TERMINAL BLOCK MODULES

9	ON SH 2. CORRECTED MATL CALLOUT. WAS ZYTEL 151. (ECN3616)	TJ	FDH	09-27-96
8	REVISED AND REDRAWN ON CAD. DWG WAS SD84122. SEE REV. REF. PRINT. (ECN3556)	FDH	JK	06-10-96
REV	REVISION DESCRIPTION	BY	CHKD	DATE

SUPERSEDES: SD84122-7

HIGH DENSITY YHLZ TERMINAL BLOCK MODULES	
CAT NO.	YHLZ16- (SEE TABLE)

LINEAR MEASURE:	INCH mm	INCH [mm]
THIRD ANGLE PROJECTION		
		
- TOLERANCES - UNLESS OTHERWISE SPECIFIED		
NO OF DECIMAL PLACES IN INCHES	INCH [mm]	
ONE PLACE	±.1 [±3]	
TWO PLACES	±.02 [±0.5]	
THREE PLACES	±.005 [±0.13]	
ANGLES ±1°		

DWG RELEASED TO CENTRAL FILE 06-10-96		
CAGE NO. 09922	ECN 3556	PC 862
© FRAMATOME CONNECTORS USA INC. 1996		



APPROVAL	DRWN	DWJ	05-31-80
	CHKD	SFP	10-16-80
	DSGN	LAS	10-24-80
	MKT	FG	05-31-96
	QC	ZR	06-05-96
DRAWING SCALE NONE			
DRAWING NO		REV	
SA84122		9	
SHEET 1 OF 5			

NOTES: UNLESS OTHERWISE SPECIFIED.

1. INTERPRET THIS DRAWING IN ACCORDANCE WITH ANSI Y14.5M-1982.
2. TERMINAL BLOCKS ACCOMODATES FCI 'ARM20W-1D_-' PIN CONTACTS. (REF: MIL-C-39029/11-145) SEE DRAWING SD84121. PIN CONTACTS ACCOMODATE WIRE RANGE #24-22-20 AWG. USE INSERTION/REMOVAL TOOL PER MIL-I-81969/1-02.
3. TERMINAL BLOCK CAN BE INSTALLED IN ANY POSITION OF AMM____T____AND AMY____T____ TRACK BY ROTATING CLOCKWISE. SEE DRAWINGS SE66784, BRSE66604, SD83863, AND SD83864.
4. MODULES ARE INTERCHANGEABLE WITH THE YHLZ8 (BACM15C2A) TERMINAL BLOCK MODULE (SEE DWG SA60450) AND ARE USED IN THE SAME TRACK.
5. UPPER AND LOWER BODIES SEALED AROUND PERIPHERY OF ALL UNBUSSED CAVITIES.
6. BARRIER IDENTIFICATION MARKING. (NON CONDUCTIVE BLACK INK)

MATERIAL:

BODY - NYLON 612 PER MIL-M-20693, TYPE III, COLOR - WHITE.
 CONTACT SPRING & RETENTION SPRING - BERYLLIUM COPPER ALLOY

FINISH:

CONTACT SPRING - .000030 [0,00076] MIN. GOLD OVER .000100 [0,00254] MIN. COPPER.

WEIGHT: .46 OZ. [13 GRAMS] MAX.

CATALOG NO. TABLE		
FCI CAT. NO.	BUSSING ARRANGEMENT	CUST. PART NO.
YHLZ16-2	8 UNITS X 2 BUSSED	BACM15C3A
YHLZ16-4	4 UNITS X 4 BUSSED	BACM15C3B
YHLZ16-8	2 UNITS X 8 BUSSED	BACM15C3C

---	ALL REV. RECORDED ON SHT 1	---	---	---
REV	REVISION DESCRIPTION	BY	CHKD	DATE

HIGH DENSITY YHLZ TERMINAL BLOCK MODULES			
CAT NO. YHLZ16- (SEE TABLE)			
DWG RELEASED TO CENTRAL FILE 06-10-96			
CAGE NO. 09922		ECN XXX	PC 862
© FRAMATOME CONNECTORS USA INC. 1996			
APP RO VAL	DRWN	DWJ	05-31-80
	CHKD	SFP	10-16-80
	DSGN	LAS	10-24-80
	MKT	FG	05-31-96
	QC	ZR	06-05-96
DRAWING SCALE: NONE			
DRAWING NO.		REV	
SA84122		9	
SHEET 2 OF 5			

LINEAR MEASURE:	INCH mm	INCH [mm]
THIRD ANGLE PROJECTION		
- TOLERANCES - UNLESS OTHERWISE SPECIFIED		
NO OF DECIMAL PLACES IN INCHES	INCH [mm]	
ONE PLACE	±.1 [±3]	
TWO PLACES	±.02 [±0.5]	
THREE PLACES	±.005 [±0.13]	
ANGLES ±1°		



PERFORMANCE CHARACTERISTICS

MECHANICAL:

CONTACT INSERTION FORCES: 2 LBS [8,90N] MAX.
 CONTACT SEPARATION FORCES: .125 LB [0,56N] MIN.
 CONTACT RETENTION: 20 LBS [88,96N] MIN.
 BUS RETENTION: 25 LBS [111,20N] MIN.

ELECTRICAL:

CONTACT RESISTANCE: SIZE 20-20: 30 MILLIVOLTS MAX AT 7.5 AMPS WITH
 20 AWG SILVER PLATED WIRE.
 LOW LEVEL CONTACT RESISTANCE: SIZE 20-20: .006 OHMS MAX WITH 20 AWG SILVER PLATED WIRE.
 DIELECTRIC WITHSTANDING VOLTAGE: 1500 VRMS
 (SEA LEVEL)
 DIELECTRIC WITHSTANDING VOLTAGE: 1000 VRMS
 (60,000 FT.)
 INSULATION RESISTANCE: 5000 MEGOHMS MIN.
 CASE INTEGRITY (WET DIELECTRIC): 1500 VRMS

ENVIRONMENTAL:

SALT SPRAY: 48 HOURS IN ACCORDANCE WITH MIL-STD-202, METHOD 101, TEST CONDITION B.
 VIBRATION: IN ACCORDANCE WITH MIL-STD-202, METHOD 204, TEST CONDITION D, LETTER E.
 THERMAL SHOCK: IN ACCORDANCE WITH MIL-STD-202, METHOD 107, TEST CONDITION B.
 EXCEPT TEMPERATURE EXTREMES ARE -55°C TO 65°C [-67°F TO 149°F]
 HUMIDITY: IN ACCORDANCE WITH MIL-STD-202, METHOD 106, (OMIT STEP 7B).
 TENSILE PULL: 10 LBS [44,48N] MIN. AT RIGHT ANGLES TO LONGITUDINAL AXIS OF CONTACT.

---	ALL REV. RECORDED ON SHT 1	---	---	---
REV	REVISION DESCRIPTION	BY	CHKD	DATE

HIGH DENSITY YHLZ TERMINAL BLOCK MODULES			
CAT NO. YHLZ16- (SEE TABLE)			

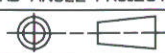
LINEAR MEASURE:	INCH mm	INCH [mm]
THIRD ANGLE PROJECTION		
		
- TOLERANCES -		
UNLESS OTHERWISE SPECIFIED		
NO OF DECIMAL PLACES IN INCHES	INCH	[mm]
ONE PLACE	±.1	[±.3]
TWO PLACES	±.02	[±0.5]
THREE PLACES	±.005	[±0.13]
ANGLES ±1°		

DWG RELEASED TO CENTRAL FILE 06-10-96
 CAGE NO. 09922 ECN 3556 PC 862

© FRAMATOME CONNECTORS USA INC. 1996



A P P R O V A L	DRWN	DWJ	05-31-80
	CHKD	SFP	10-16-80
	DSGN	LAS	10-24-80
	MKT	FG	05-31-96
	QC	ZR	06-05-96
DRAWING SCALE: NONE			
DRAWING NO.		REV	
SA84122		9	
SHEET 3 OF 5			

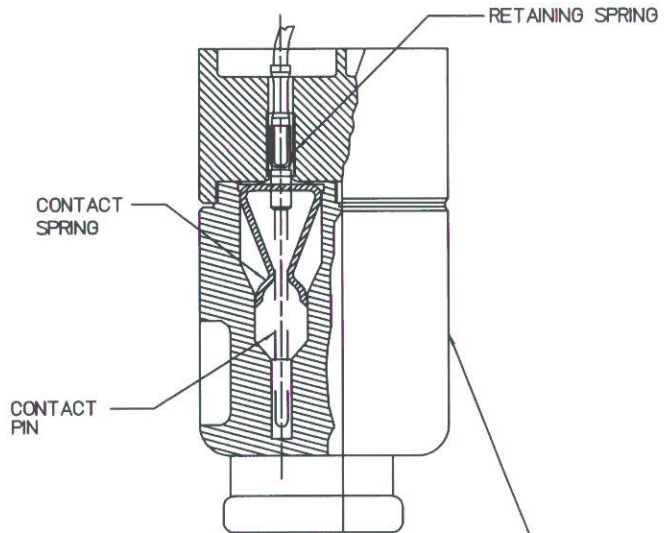
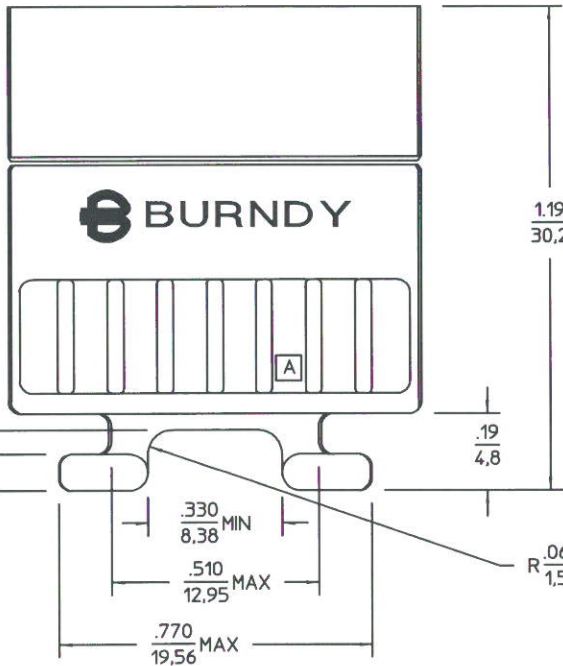

CUSTOMER PART NUMBER
FCI CAT. NUMBER

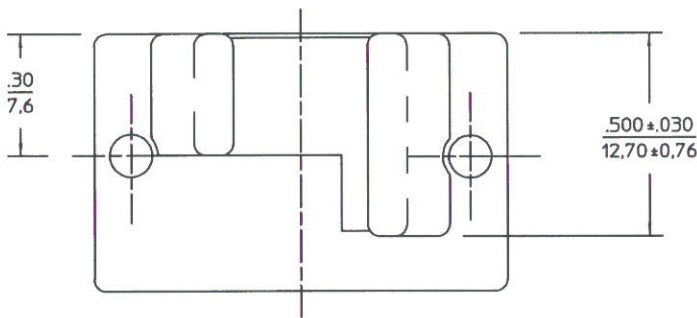

---	ALL REV. RECORDED ON SHT 1	---	---	---
REV	REVISION DESCRIPTION	BY	CHKD	DATE

HIGH DENSITY YHLZ TERMINAL BLOCK MODULES

CAT NO. YHLZ16- (SEE TABLE)

DWG RELEASED TO CENTRAL FILE 06-10-96

CAGE NO. 09922 ECN 3556 PC 862

© FRAMATOME CONNECTORS USA INC. 1996

LINEAR MEASURE:	INCH mm	INCH [mm]
THIRD ANGLE PROJECTION		
- TOLERANCES - UNLESS OTHERWISE SPECIFIED		
NO OF DECIMAL PLACES IN INCHES	INCH [mm]	
ONE PLACE	±.1 [±3]	
TWO PLACES	±.02 [±0.5]	
THREE PLACES	±.005 [±0.13]	
ANGLES ±1°		

APPROVAL	DRWN	DWJ	05-31-80
	CHKD	SFP	10-16-80
	DSGN	LAS	10-24-80
	MKT	FG	05-31-96
	QC	ZR	06-05-96
DRAWING SCALE 2 : 1			
DRAWING NO		REV	
SA84122		9	
SHEET 4 OF 5			

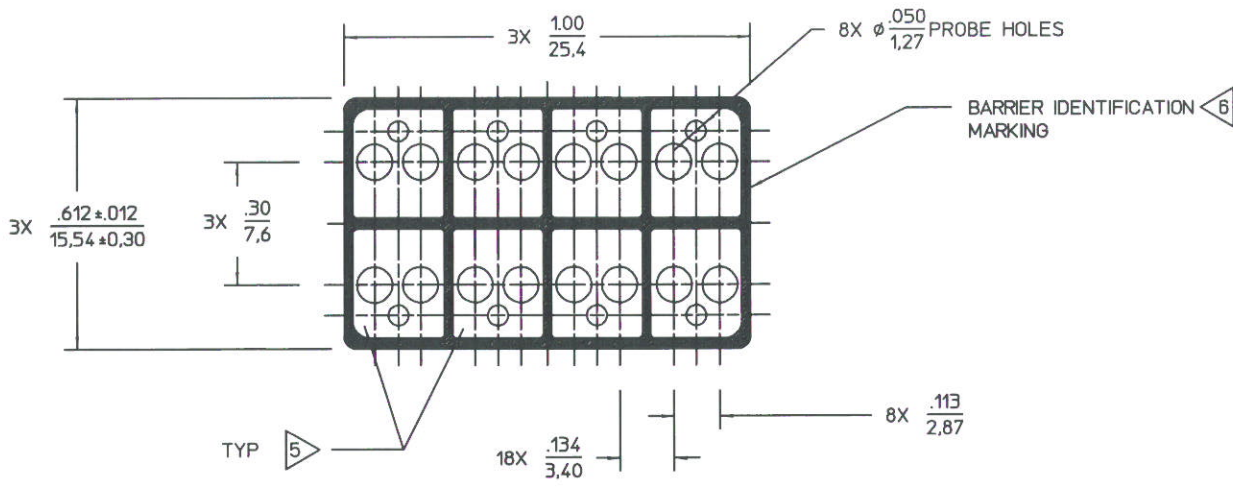

YHLZ16-2 (BACM15C3A)
8 UNITS OF 2 BUSSED TOGETHER

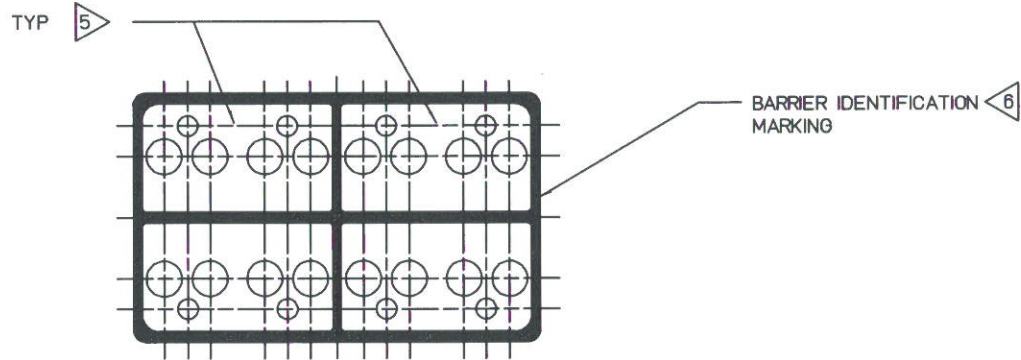

YHLZ16-4 (BACM15C3B)
4 UNITS OF 4 BUSSED TOGETHER

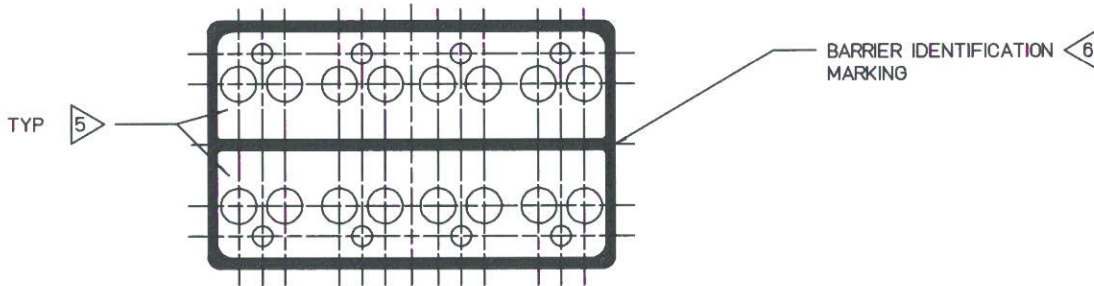

YHLZ16-8 (BACM15C3C)
2 UNITS OF 8 BUSSED TOGETHER

---	ALL REV. RECORDED ON SHT 1	---	---	---
REV	REVISION DESCRIPTION	BY	CHKD	DATE

HIGH DENSITY YHLZ TERMINAL BLOCK MODULES

CAT NO. YHLZ16- (SEE TABLE)

DWG RELEASED TO CENTRAL FILE XX-XX-XX

CAGE NO. 09922 | ECN 3556 | PC 862

© FRAMATOME CONNECTORS USA INC. 1996

LINEAR MEASURE:	INCH mm	INCH [mm]
THIRD ANGLE PROJECTION		
- TOLERANCES - UNLESS OTHERWISE SPECIFIED		
NO OF DECIMAL PLACES IN INCHES	INCH [mm]	
ONE PLACE	±.1 [±3]	
TWO PLACES	±.02 [±0.5]	
THREE PLACES	±.005 [±0.13]	
ANGLES ±1°		



A P P R O V A L	DRWN DWJ 05-31-80
	CHKD SFP 10-16-80
	DSGN LAS 10-24-80
	MKT FG 05-31-96
	QC ZR 06-05-96
DRAWING SCALE 2 : 1	
DRAWING NO	REV
SA84122	9
SHEET 5 OF 5	



Компания «ЭлектроПласт» предлагает заключение долгосрочных отношений при поставках импортных электронных компонентов на взаимовыгодных условиях!

Наши преимущества:

- Оперативные поставки широкого спектра электронных компонентов отечественного и импортного производства напрямую от производителей и с крупнейших мировых складов;
- Поставка более 17-ти миллионов наименований электронных компонентов;
- Поставка сложных, дефицитных, либо снятых с производства позиций;
- Оперативные сроки поставки под заказ (от 5 рабочих дней);
- Экспресс доставка в любую точку России;
- Техническая поддержка проекта, помощь в подборе аналогов, поставка прототипов;
- Система менеджмента качества сертифицирована по Международному стандарту ISO 9001;
- Лицензия ФСБ на осуществление работ с использованием сведений, составляющих государственную тайну;
- Поставка специализированных компонентов (Xilinx, Altera, Analog Devices, Intersil, Interpoint, Microsemi, Aeroflex, Peregrine, Syfer, Eurofarad, Texas Instrument, Miteq, Cobham, E2V, MA-COM, Hittite, Mini-Circuits, General Dynamics и др.);

Помимо этого, одним из направлений компании «ЭлектроПласт» является направление «Источники питания». Мы предлагаем Вам помощь Конструкторского отдела:

- Подбор оптимального решения, техническое обоснование при выборе компонента;
- Подбор аналогов;
- Консультации по применению компонента;
- Поставка образцов и прототипов;
- Техническая поддержка проекта;
- Защита от снятия компонента с производства.



Как с нами связаться

Телефон: 8 (812) 309 58 32 (многоканальный)

Факс: 8 (812) 320-02-42

Электронная почта: org@eplast1.ru

Адрес: 198099, г. Санкт-Петербург, ул. Калинина, дом 2, корпус 4, литера А.