

# QR/P SERIES PLUG-IN CRIMP CONNECTORS

## General

QR/P series connectors have been developed for Plug-in Connection Power and Signal Circuits in copier machine or other equipments which impose the connectors repeated insertion and extraction for maintenance work of them Available number of pins are 4, 8,

12, 16, and 24. Wire termination is done by crimping which offers higher reliability, Especially, the unique sexless contact assures soft and smooth coupling operation which is the most appropriate for Plug-in connection by machine itself.

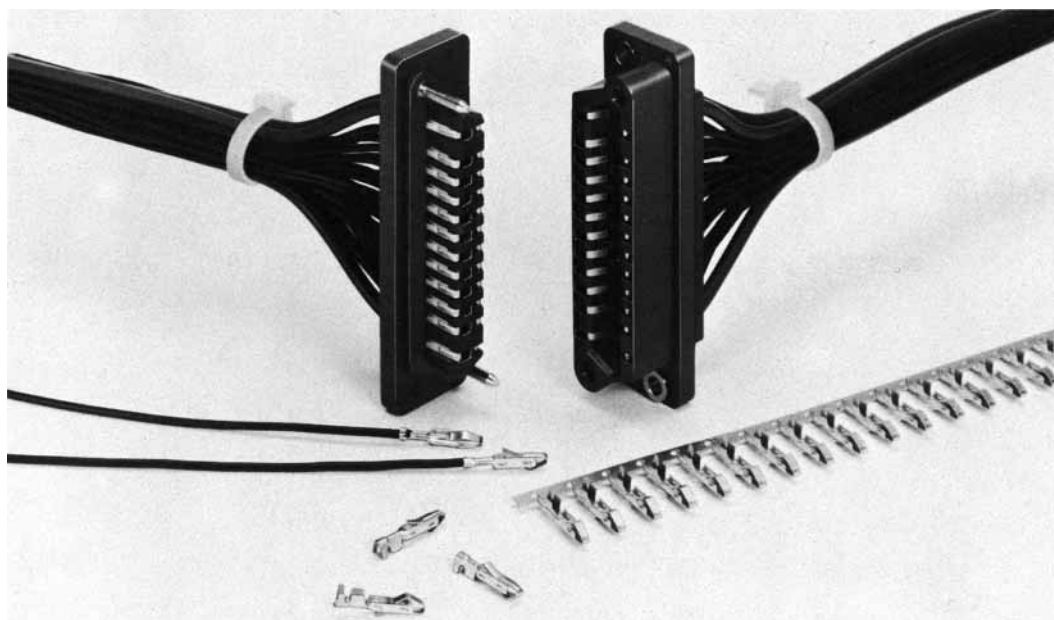

## Features

- (1) The selective plating sexless contact is commonly used for plug and receptacle housings.
- (2) As QR/P series are crimp type connectors their housing and contacts are supplied separately. The sexless feature of the contact offers customers higher utilization and easier inventory control.
- (3) The two pairs of contacts at both ends are sequenced for power circuits. They are longer than the others.

The molding material is UL94V-0 glass-reinforced polyester.

- (4) The Guide Pin is made of steel nickel plated to be strong enough against accidental coupling shock.
- (5) The mount of a receptacle housing is done through Floating Bushes. Thus, they may help to give smoother coupling of connectors by a self-adjusting function.

## Applications

Main applications are PPC, Data Communications, Vending Machines, Instrument, Automatic Equipment, etc.

## Material and Finish

QR/P Main Rating		
Contact resistance	10 Ω or less at DC1A	
Insulation resistance	5000M Ω or less at DC 500V	
Withstand voltage (1 min.)	Power	AC 3000V
	Signal	AC 1000V
Current rating	Power	13A Max (AWG#14 use)
	Signal	7A Max (AWG#14 use)
Voltage rating	Power	AC 600V
	Signal	AC 250V

Material		
Insulator	PBT*	Blue
Contact	Phosphor bronze	Selective gold over Nickel Plating

※UL94V-0

Ratings authorized by QR/P safety standards				
Standard safety		UL	CSA	TÜV
operating temperature		- 10~ +60°C		
Rated voltage	Power	AC120V	AC125V	AC250V, DC300V
	Signal			AC125V, DC150V
Rated current	AWG#14	10A	—	10A
	AWG#16		5A	
	AWG#18	3A	3A	5A
	AWG#20		2A	2.5A
	AWG#22		1A	1A
AWG#24				

## Ordering Information

### ▲ Connector Unit

QR / P — 8 P — C (01)  
 (1) (2)(3) (4) (9)

### ▲ Contact

QR / P — X C — 1 1 1  
 (1) (5)(4) (6)(7)(8)

- (1) Series Name
- (2) No. of Pin 4, 8, 12, 16, 24
- (3) Type of Housing  
 P: Plug Housing  
 S: Receptacle Housing
- (4) Type of Termination  
 C: Crimping
- (5) Sexless Contact
- (6) Contact Type  
 1: Loose Contact  
 2: Chain Contact
- (7) Applicable Wire  
 1: AWG # 14 - # 16  
 2: AWG # 18 - # 24
- (8) Finish  
 1: Selective Gold over Nickel plating
- (9) UL, CSA, TÜV Approved Spec.

## Plug Housing

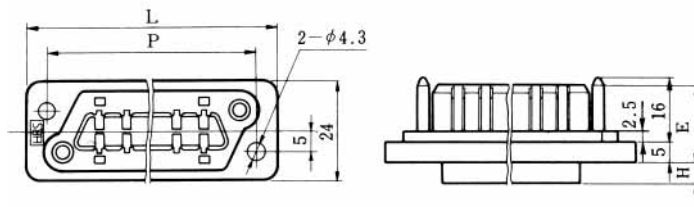

Unit: mm

HRS No.	No. of Pin	Part No.	L	P	H	E	RoHS
CL221-0013-0-01	4	QR/P- 4P-C (01)	41	31	5	18.5	○
CL221-0001-0-01	8	QR/P- 8P-C (01)	52	42	5	18.5	
CL221-0002-3-01	12	QR/P-12P-C (01)	61	51	5	18.5	
CL221-0003-6-01	16	QR/P-16P-C (01)	70	60	5	18.5	
CL221-0004-9-01	24	QR/P-24P-C (01)	86.5	77	5.5	18	

## Receptacle Housing

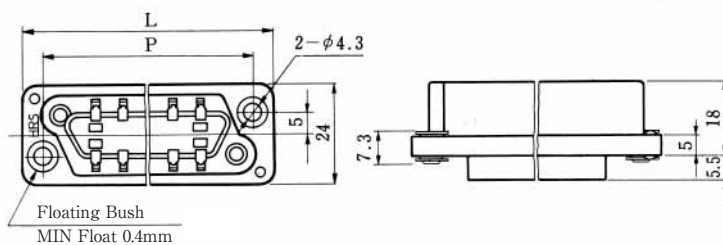

Unit: mm

HRS No.	No. of Pin	Part No.	L	P	RoHS
CL221-0014-2-51	4	QR/P- 4S-C (51)	41	31	○
CL221-0005-1-51	8	QR/P- 8S-C (51)	52	42	
CL221-0006-4-51	12	QR/P-12S-C (51)	61	51	
CL221-0007-7-51	16	QR/P-16S-C (51)	70	60	
CL221-0008-0-51	24	QR/P-24S-C (51)	86.5	77	

## Sexless Crimp Contact

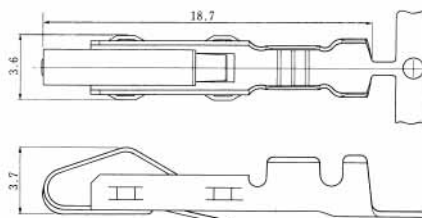
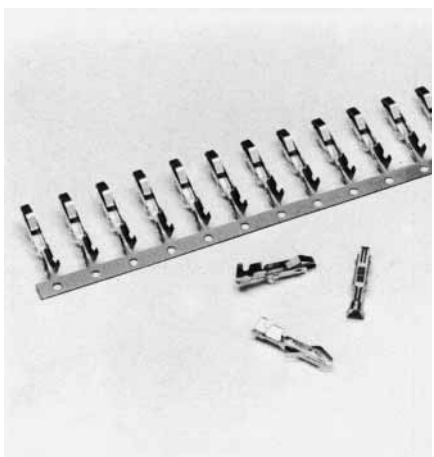

Unit: mm

Applicable Wire	HRS No.	Part No.	Type	Plating	RoHS
AWG#14 - 16	CL221-0009-2-12	QR/P-XC-111 (12)	Loose	Selective gold over Nickel Plating	○
	CL221-0011-4-12	QR/P-XC-211 (12)	Chain		
AWG#18 - 24	CL221-0010-1-12	QR/P-XC-121 (12)	Loose		
	CL221-0012-7-12	QR/P-XC-221 (12)	Chain		

Note\* Loose-piece terminals are available in packs. Each pack contains 100 terminals. Strip terminals are available in reels. Each reel contains QR/P-XC-221 Pin 3,500. QR/P-XC-221 Pin 5,000 terminals.

## How To Use Connectors

QR/P series connectors are primarily used in Plug-in Connection and the use is shown below.

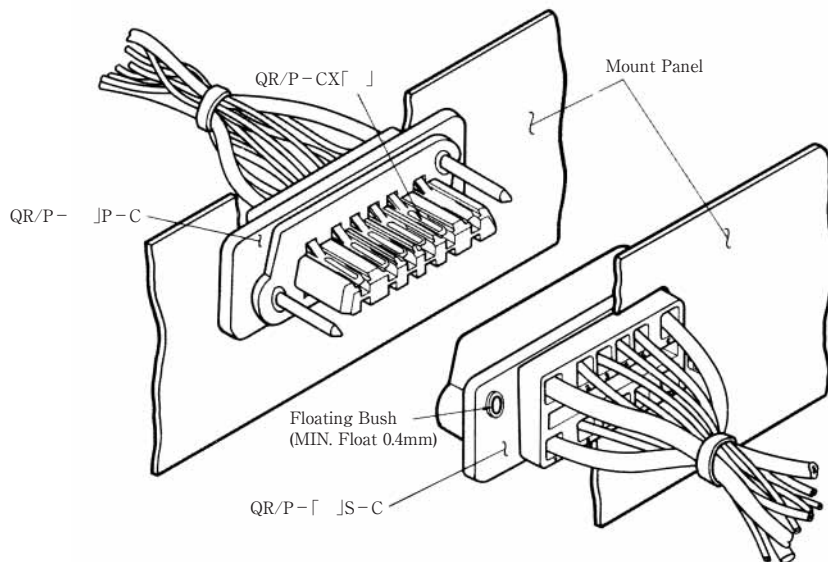

Note: Determine the combinations with the panel so that the mating clearance between the P side and S side is 2 mm or less.

## Recommended Mounting Hole (for S Insulation Case)

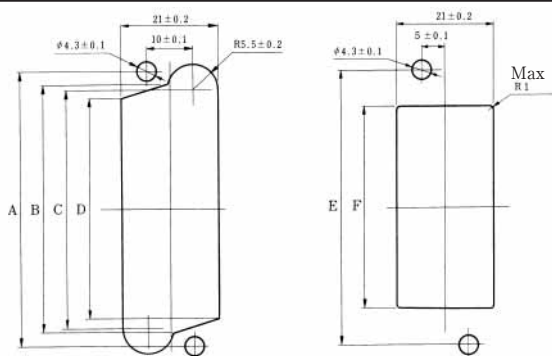

No. of pin		4 pin	8 pin	12 pin	16 pin	24 pin
Rear Mounting	A	31	42	51	60	70
	B	26.5	37.5	46.5	55.5	73.5
	C	23	34	43	52	70
	D	18.5	29.5	38.5	47.5	65.5
Front Mounting	E	31	42	51	60	77
	F	15.5	26.5	35.5	44.5	62.5

Note: Panel mounting dimensions for the P insulation case are symmetrical with request to the vertical axis, in relation to the S insulation case.

## Tools

Item	HRS No.	Part No.	Applicable Contact	Applicable Cable
Hand Crimp Tool	CL250-0027-0	TC-2100-111	QR/P-XC-111	AWG#14 - #16
	CL250-0028-2	TC-2100-121	QR/P-XC-121	AWG#18 - #24
Applicator	CL901-2531-8	AP105-QR/P-XC-221	QR/P-XC-221	AWG#18 - #24
Contact Extraction Tool	CL250-0009-8	TC-2100-21	—	—

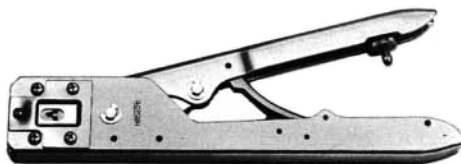

Hand Crimp Tool



Contact Extraction Tool

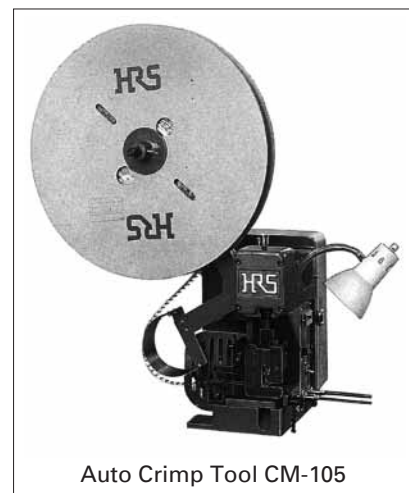

Auto Crimp Tool CM-105

## Assembling Procedure

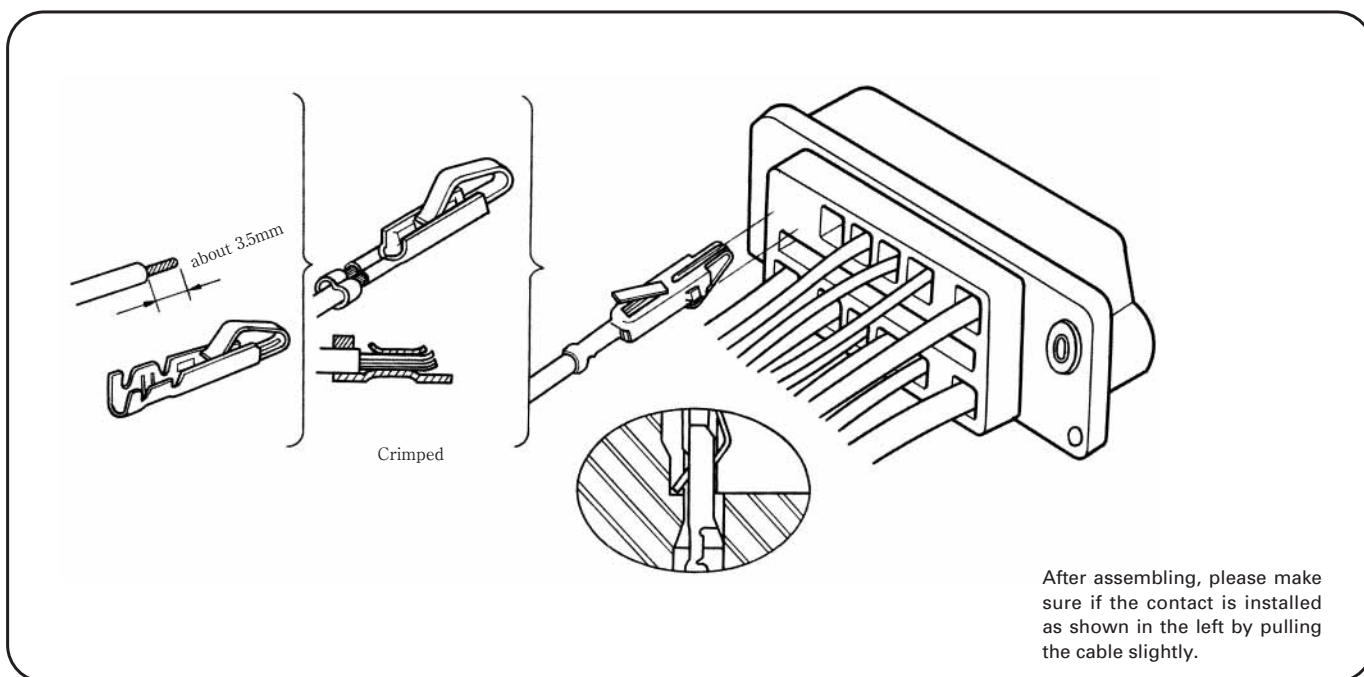

## Procedure for Contact Extraction

In case of extracting a contact from the housing in insertion error or in circuit change, follow the steps as shown below.

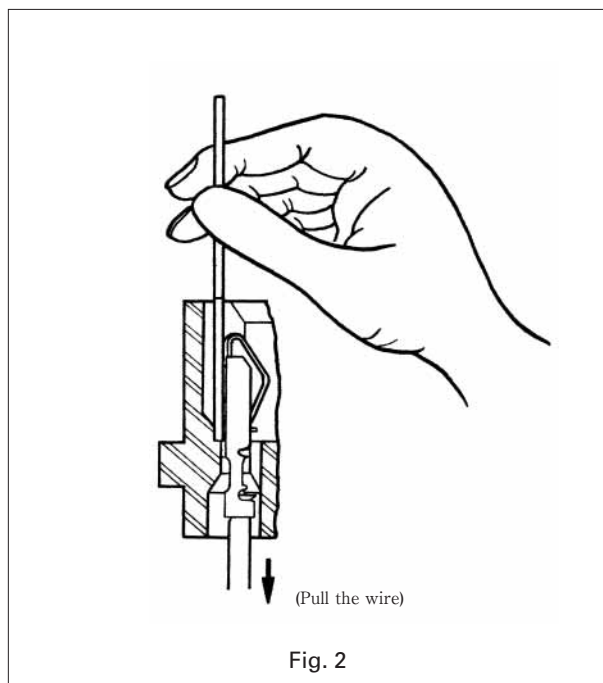
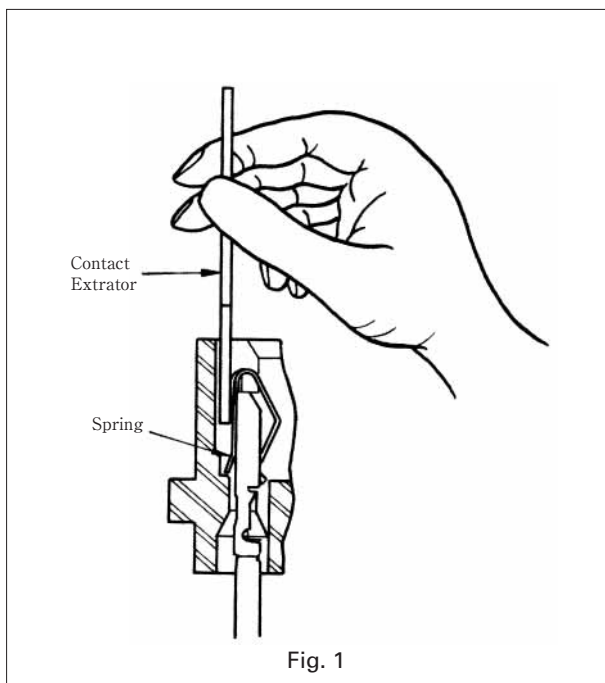

1. Hold the Contact Extractor, placing the tip of the Extractor on the tip of a contact, then insert it between the contact and the housing, following to the Fig. 1.
2. When the tip of the Extractor comes into contact with a stepped part in the housing, the spring will come off from the stepped part with a snap which is felt. Then, extract the contact by pulling the wire.
3. Above Fig. 1 and Fig. 2 show how to extract a contact from socket housing. The same procedure can be employed to extract a contact from pin housing.
4. When the extracted contact is installed again in the housing, do not forget to raise up the contact spring to the original position.



Компания «ЭлектроПласт» предлагает заключение долгосрочных отношений при поставках импортных электронных компонентов на взаимовыгодных условиях!

Наши преимущества:

- Оперативные поставки широкого спектра электронных компонентов отечественного и импортного производства напрямую от производителей и с крупнейших мировых складов;
- Поставка более 17-ти миллионов наименований электронных компонентов;
- Поставка сложных, дефицитных, либо снятых с производства позиций;
- Оперативные сроки поставки под заказ (от 5 рабочих дней);
- Экспресс доставка в любую точку России;
- Техническая поддержка проекта, помощь в подборе аналогов, поставка прототипов;
- Система менеджмента качества сертифицирована по Международному стандарту ISO 9001;
- Лицензия ФСБ на осуществление работ с использованием сведений, составляющих государственную тайну;
- Поставка специализированных компонентов (Xilinx, Altera, Analog Devices, Intersil, Interpoint, Microsemi, Aeroflex, Peregrine, Syfer, Eurofarad, Texas Instrument, Miteq, Cobham, E2V, MA-COM, Hittite, Mini-Circuits, General Dynamics и др.);

Помимо этого, одним из направлений компании «ЭлектроПласт» является направление «Источники питания». Мы предлагаем Вам помощь Конструкторского отдела:

- Подбор оптимального решения, техническое обоснование при выборе компонента;
- Подбор аналогов;
- Консультации по применению компонента;
- Поставка образцов и прототипов;
- Техническая поддержка проекта;
- Защита от снятия компонента с производства.



#### Как с нами связаться

**Телефон:** 8 (812) 309 58 32 (многоканальный)

**Факс:** 8 (812) 320-02-42

**Электронная почта:** [org@eplast1.ru](mailto:org@eplast1.ru)

**Адрес:** 198099, г. Санкт-Петербург, ул. Калинина, дом 2, корпус 4, литера А.