

# AMIS-42700

## Dual High Speed CAN Transceiver

### General Description

Controller area network (CAN) is a serial communication protocol, which supports distributed real-time control and multiplexing with high safety level. Typical applications of CAN-based networks can be found in automotive and industrial environments.

The AMIS-42700 Dual-CAN transceiver is the interface between up to two physical bus lines and the protocol controller and will be used for serial data interchange between different electronic units at more than one bus line. It can be used for both 12 V and 24 V systems.

The circuit consists of following blocks:

- Two differential line transmitters
- Two differential line receivers
- Interface to the CAN protocol handler
- Interface to expand the number of CAN busses
- Logic block including repeater function and the feedback suppression
- Thermal shutdown circuit (TSD)
- Short to battery treatment circuit

Due to the wide common-mode voltage range of the receiver inputs, the AMIS-42700 is able to reach outstanding levels of electromagnetic susceptibility (EMS). Similarly, extremely low electromagnetic emission (EME) is achieved by the excellent matching of the output signals.

### Key Features

- Fully compatible with the ISO 11898-2 standard
- Certified “Authentication on CAN Transceiver Conformance (d1.1)”
- High speed (up to 1 Mbit/s in function of the bus topology)
- Ideally suited for 12 V and 24 V industrial and automotive applications
- Low EME common-mode-choke is no longer required
- Differential receiver with wide common-mode range ( $\pm 35$  V) for high EMS
- No disturbance of the bus lines with an un-powered node
- Dominant time-out function
- Thermal protection
- Bus pins protected against transients in an automotive environment
- Short circuit proof to supply voltage and ground



ON Semiconductor®

<http://onsemi.com>

### PIN CONFIGURATION

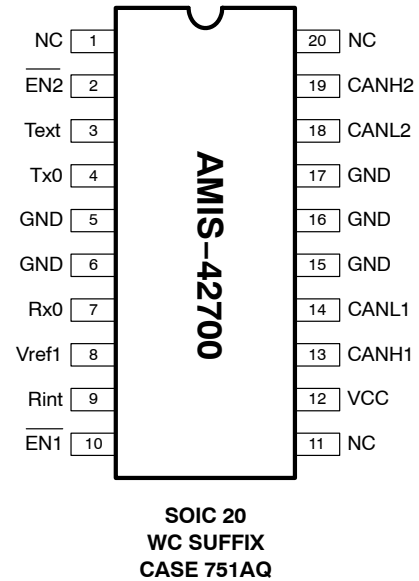

### ORDERING INFORMATION

See detailed ordering and shipping information in the package dimensions section on page 12 of this data sheet.

# AMIS-42700

**Table 1. Technical Characteristics**

Symbol	Parameter	Conditions	Min.	Max.	Unit
$V_{CANHx}$	DC voltage at pin CANH1/2	$0 < V_{CC} < 5.25 \text{ V}$ ; no time limit	-45	+45	V
$V_{CANLx}$	DC voltage at pin CANL1/2	$0 < V_{CC} < 5.25 \text{ V}$ ; no time limit	-45	+45	V
$V_{O(dif)(bus\_dom)}$	Differential bus output voltage in dominant state	$42.5 \Omega < R_{LT} < 60 \Omega$	1.5	3	V
CM-range	Input common-mode range for comparator	Guaranteed differential receiver threshold and leakage current	-35	+35	V
$V_{CM-peak}$	Common-mode peak	See Figures 9 and 10 (Note 1)	-1000	1000	mV
$V_{CM-step}$	Common-mode step	See Figures 9 and 10 (Note 1)	-250	250	mV

1. The parameters  $V_{CM-peak}$  and  $V_{CM-step}$  guarantee low EME.

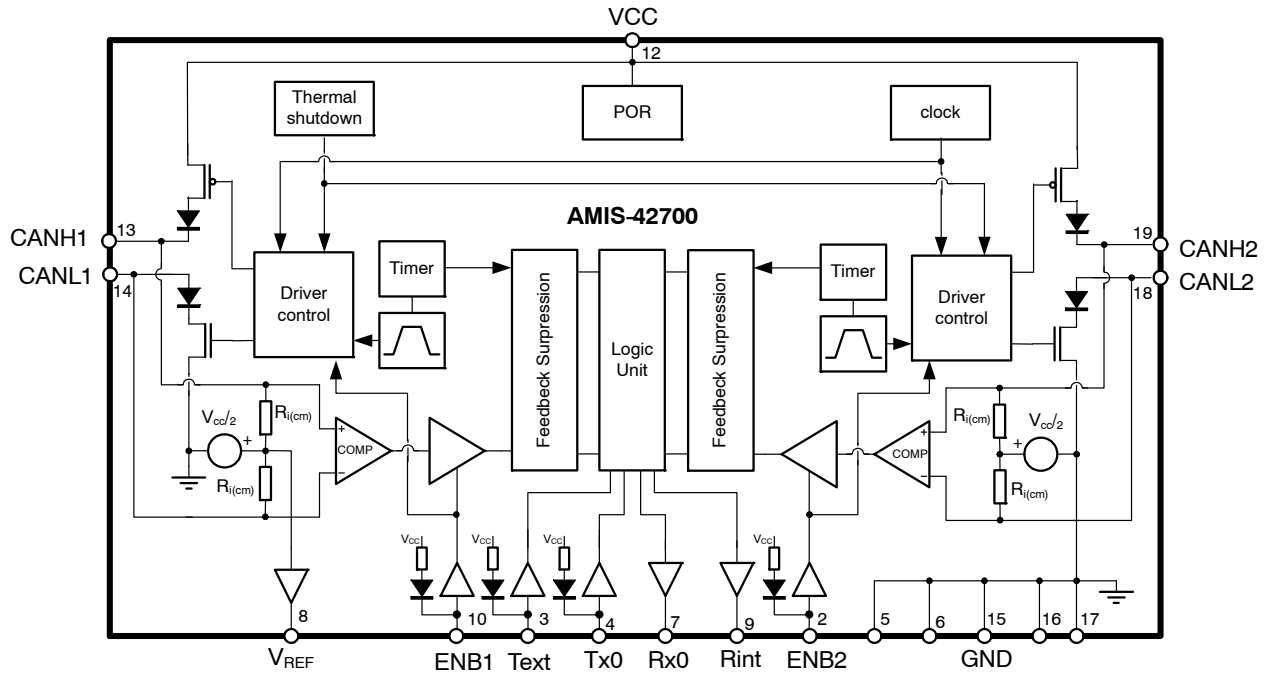

**Figure 1. Block Diagram**

## Typical Application

### Application Description

AMIS-42700 is especially designed to provide the link between a CAN controller (protocol IC) and two physical busses. It is able to operate in three different modes:

- Dual CAN
- A CAN-bus extender
- A CAN-bus repeater

# AMIS-42700

## Application Schematics

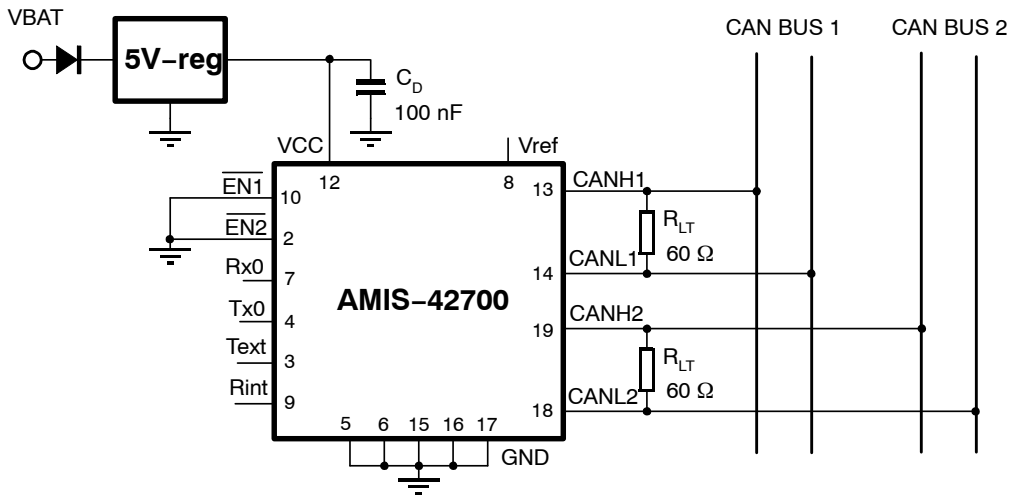

Figure 2. Application Diagram CAN-bus Repeater

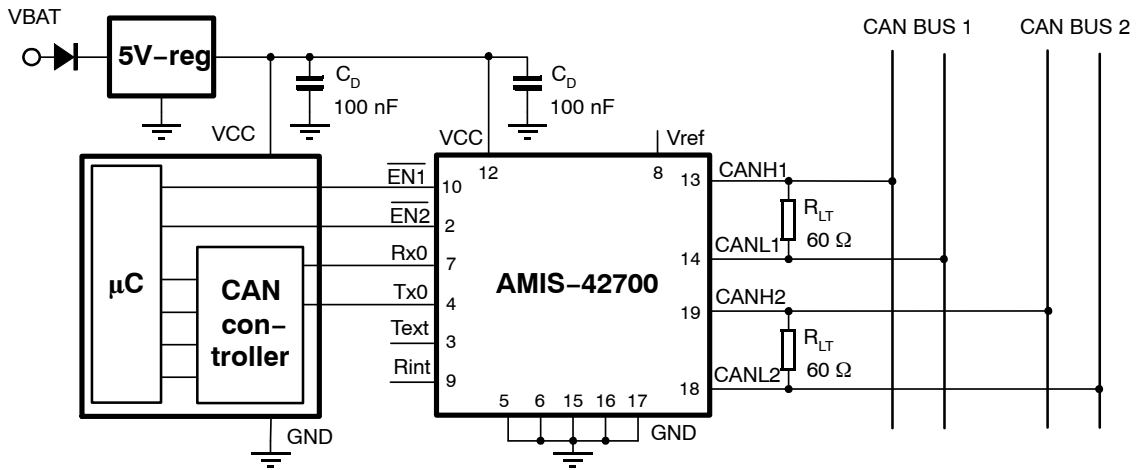
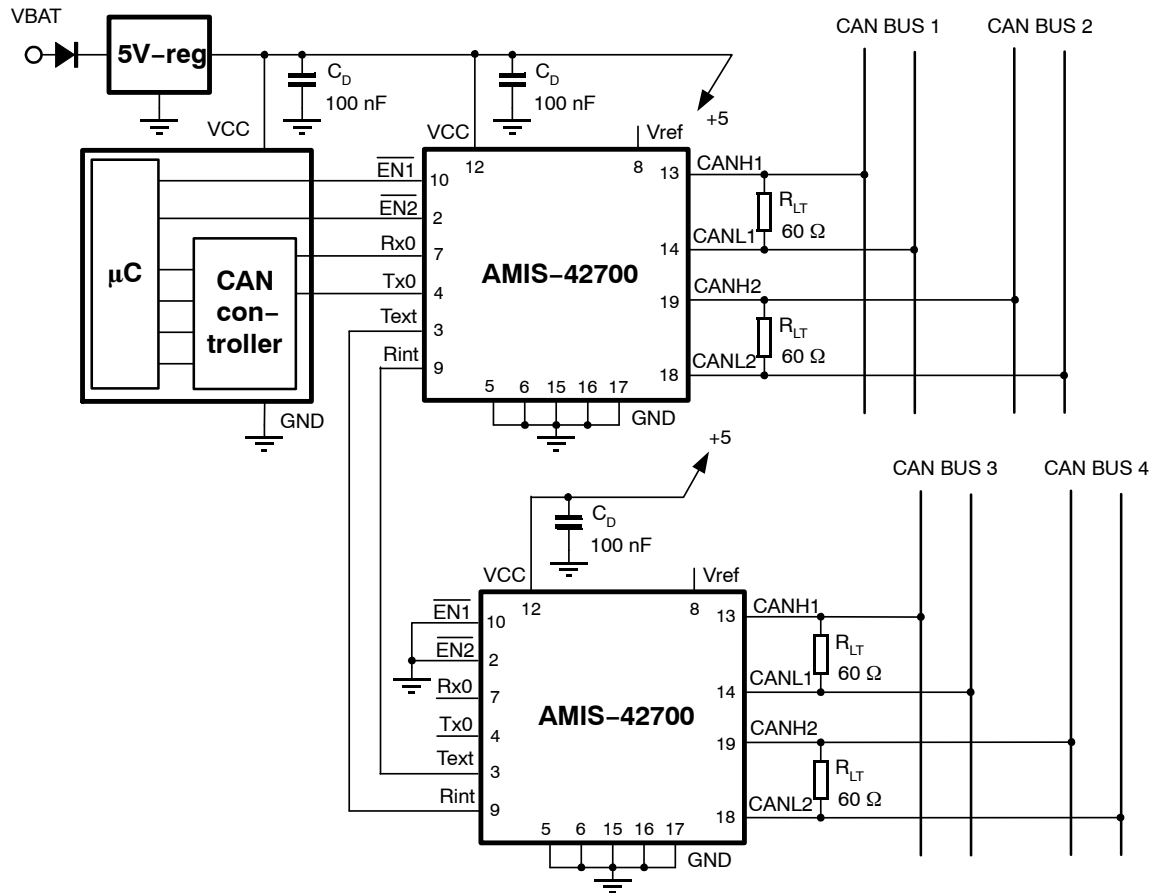

Figure 3. Application Diagram Dual-CAN

## AMIS-42700



**Figure 4. Application Diagram CAN-bus Extender**

**Table 2. Pin Out**

Pin	Name	Description
1	NC	Not connected
2	ENB2	Enable input, bus system 2; internal pull-up
3	Text	Multi-system transmitter Input; internal pull-up
4	Tx0	Transmitter input; internal pull-up
5	GND	Ground connection (Note 2)
6	GND	Ground connection (Note 2)
7	Rx0	Receiver output
8	V <sub>REF1</sub>	Reference voltage
9	Rint	Multi-system receiver output
10	ENB1	Enable input, bus system 1; internal pull-up
11	NC	Not connected
12	VCC	Positive supply voltage
13	CANH1	CANH transceiver I/O bus system 1
14	CANL1	CANL transceiver I/O bus system 1
15	GND	Ground connection (Note 2)
16	GND	Ground connection (Note 2)
17	GND	Ground connection (Note 2)
18	CANL2	CANL transceiver I/O bus system 2
19	CANH2	CANH transceiver I/O bus system 2
20	NC	Not connected

2. In order to ensure the chip performance, all these pins need to be connected to GND on the PCB.

## Functional Description

### Overall Functional Description

AMIS-42700 is specially designed to provide the link between the protocol IC (CAN controller) and two physical bus lines. Data interchange between those two bus lines is realized via the logic unit inside the chip. To provide an independent switch-off of the transceiver units for both bus systems by a third device (e.g. the  $\mu$ C), enable-inputs for the corresponding driving and receiving sections are provided. As long as both lines are enabled, they appear as one logical bus to all nodes connected to either of them.

The bus lines can have two logical states, dominant or recessive. A bus is in the recessive state when the driving sections of all transceivers connected to the bus are passive. The differential voltage between the two wires is approximately zero. If at least one driver is active, the bus changes into the dominant state. This state is represented by a differential voltage greater than a minimum threshold and therefore by a current flow through the terminating resistors of the bus line. The recessive state is overwritten by the dominant state.

In case of a fault (like short circuit) is present on one of the bus lines, it remains limited to that bus line where it occurs. Data interchange from the protocol IC to the other bus system and on this bus system itself can be continued.

AMIS-42700 can be also used for only one bus system. If the connections for the second bus system are simply left open it serves as a single transceiver for an electronic unit. For correct operation, it is necessary to terminate the open bus by the proper termination resistor.

### Logic Unit and CAN Controller Interface

The logic unit inside AMIS-42700 provides data transfer from/to the digital interface to/from the two busses and from one bus to the other bus. The detailed function of the logic unit is described in Table 3.

All digital input pins, including ENBx, have an internal pull-up resistor to ensure a recessive state when the input is

not connected or is accidentally interrupted. A dominant state on the bus line is represented by a low-level at the digital interface; a recessive state is represented by a high-level.

Dominant state received on any bus (if enabled) causes a dominant state on both busses, pin Rint and pin Rx0. Dominant signal on any of the input pins Tx0 and Text causes transmission of dominant on both bus lines (if enabled).

Digital inputs Tx0 and Text are used for connecting the internal logic's of several IC's to obtain versions with more than two bus outputs (see Figure 4: Application Diagram CAN-bus Extender). They have also a direct logical link to pins Rx0 and Rint independently on the EN1x pins – dominant on Tx0 is directly transferred to both Rx0 and Rint pins, dominant on Text is only transferred to Rx0.

### Transmitters

The transceiver includes two transmitters, one for each bus line, and a driver control circuit. Each transmitter is implemented as a push and a pull driver. The drivers will be active if the transmission of a dominant bit is required. During the transmission of a recessive bit all drivers are passive. The transmitters have a built-in current limiting circuit that protects the driver stages from damage caused by accidental short circuit to either positive supply voltage or to ground. Additionally a thermal protection circuit is integrated.

The driver control circuit ensures that the drivers are switched on and off with a controlled slope to limit EME. The driver control circuit will be controlled itself by the thermal protection circuit, the timer circuit and the logic unit.

The enable signal ENBx allows the transmitter to be switched off by a third device (e.g. the  $\mu$ C). In the disabled state (ENBx = high) the corresponding transmitter behaves as in the recessive state.

**Table 3. Function of the Logic Unit** (bold letters describe input signals)

EN1B	EN2B	TX0	TEXT	Bus 1 State	Bus 2 State	RX0	RINT
0	0	0	0	dominant	dominant	0	0
0	0	0	1	dominant	dominant	0	0
0	0	1	0	dominant	dominant	0	1
0	0	1	1	recessive	recessive	1	1
0	0	1	1	<b>dominant</b> (Note 3)	dominant	0	0
0	0	1	1	dominant	<b>dominant</b> (Note 3)	0	0
0	1	0	0	dominant	recessive	0	0
0	1	0	1	dominant	recessive	0	0
0	1	1	0	dominant	recessive	0	1
0	1	1	1	recessive	recessive	1	1
0	1	1	1	<b>dominant</b> (Note 3)	recessive	0	0

3. Dominant detected by the corresponding receiver.

**Table 3. Function of the Logic Unit** (bold letters describe input signals)

EN1B	EN2B	TX0	TEXT	Bus 1 State	Bus 2 State	RX0	RINT
0	1	1	1	recessive	<b>dominant</b> (Note 3)	1	1
1	0	0	0	recessive	dominant	0	0
1	0	0	1	recessive	dominant	0	0
1	0	1	0	recessive	dominant	0	1
1	0	1	1	recessive	recessive	1	1
1	0	1	1	<b>dominant</b> (Note 3)	recessive	1	1
1	0	1	1	recessive	<b>dominant</b> (Note 3)	0	0
1	1	0	0	recessive	recessive	0	0
1	1	0	1	recessive	recessive	0	0
1	1	1	0	recessive	recessive	0	1
1	1	1	1	recessive	recessive	1	1
1	1	1	1	<b>dominant</b> (Note 3)	recessive	1	1
1	1	1	1	recessive	<b>dominant</b> (Note 3)	1	1

3. Dominant detected by the corresponding receiver.

### Receivers

Two bus receiving sections sense the states of the bus lines. Each receiver section consists of an input filter and a fast and accurate comparator. The aim of the input filter is to improve the immunity against high-frequency disturbances and also to convert the voltage at the bus lines CANHx and CANLx, which can vary from -12 V to +12 V, to voltages in the range 0 to 5 V, which can be applied to the comparators.

The output signal of the comparators is gated by the ENBx signal. In the disabled state (ENBx = high), the output signal of the comparator will be replaced by a permanently recessive state and does not depend on the bus voltage. In the enabled state the receiver signal sent to the logic unit is identical to the comparator output signal.

### Time-out Counters

To avoid that the transceiver drives a permanent dominant state on either of the bus lines (blocking all communication), time-out function is implemented. Signals on pins Tx0 and Text as well as both bus receivers are connected to the logic unit through independent timers. If the input of the timer stays dominant for longer than parameter tdom, it's replaced by a recessive signal on the timer output.

### Feedback Suppression

The logic unit described in Table 3 constantly ensures that dominant symbols on one bus line are transmitted to the other bus line without imposing any priority on either of the lines. This feature would lead to an "interlock" state with permanent dominant signal transmitted to both bus lines, if no extra measure is taken.

Therefore a feedback suppression is included inside the logic unit of the transceiver. This block masks-out reception

on that bus line, on which a dominant is actively transmitted. The reception becomes active again only with certain delay after the dominant transmission on this line is finished.

### Power-on-Reset (POR)

While Vcc voltage is below the POR level, the POR circuit makes sure that:

- The counters are kept in the reset mode and stable state without current consumption
- Inputs are disabled (don't care)
- Outputs are high impedant; only Rx0 = high-level
- Analog blocks are in power down
- Oscillator not running and in power down
- CANHx and CANLx are recessive
- VREF output high impedant for POR not released

### Over Temperature Detection

A thermal protection circuit is integrated to prevent the transceiver from damage if the junction temperature exceeds thermal shutdown level. Because the transmitters dissipate most of the total power, the transmitters will be switched off only to reduce power dissipation and IC temperature. All other IC functions continue to operate.

### Fault Behavior

A fault like a short circuit is limited to that bus line where it occurs; hence data interchange from the protocol IC to the other bus system is not affected.

When the voltage at the bus lines is going out of the normal operating range (-12 V to +12 V), the receiver is not allowed to erroneously detect a dominant state.

**Short Circuits**

As specified in the maximum ratings, short circuits of the bus wires CANHx and CANLx to the positive supply voltage Vbat or to ground must not destroy the transceiver. A short circuit between CANHx and CANLx must not destroy the IC as well.

The dedicated comparator (L2VBAT) on CANL pin detects the short to battery and after debounce time-out switches off the affected driver only. The receiver of the affected driver has to operate normally.

**Faulty Supply**

In case of a faulty supply (missing connection of the electronic unit or the transceiver to ground, missing connection of the electronic unit to Vbat or missing connection of the transceiver to Vcc), the power supply module of the electronic unit will operate such that the transceiver is not supplied, i.e. the voltage Vcc is below the POR level. In this condition the bus connections of the transceiver must be in the POR state.

If the ground line of the electronic unit is interrupted, Vbat may be applied to the Vcc pin (measured relative to the original ground potential, to which the other units on the bus are connected).

**Reverse Electronic Unit (ECU) Supply**

If the connections for ground and supply voltage of an electronic unit (ECU) (max. 50 V) which provides Vcc for the transceiver are exchanged, this transceiver has a ground potential which may be up to 50 V higher than that of the other transceivers. In this case no transceiver must be destroyed even if several of them are connected via the bus system.

Any exchange among the six connections CANH1, CANH2, CANL1, CANL2, ground, and supply voltage of the electronic unit at the connector of the unit must never lead to the destruction of any transceiver of the bus system.

**Electrical Characteristics**

**Definitions**

All voltages are referenced to GND. Positive currents flow into the IC. Sinking current means that the current is flowing into the pin. Sourcing current means that the current is flowing out of the pin.

**Absolute Maximum Ratings**

Stresses above those listed in Table 4 may cause permanent device failure. Exposure to absolute maximum ratings for extended periods may affect device reliability.

**Table 4. Absolute Maximum Ratings**

Symbol	Parameter	Conditions	Min.	Max.	Unit
V <sub>CC</sub>	Supply voltage		-0.3	+7	V
V <sub>CANHx</sub>	DC voltage at pin CANH1/2	0 < V <sub>CC</sub> < 5.25 V; no time limit	-45	+45	V
V <sub>CANLx</sub>	DC voltage at pin CANL1/2	0 < V <sub>CC</sub> < 5.25 V; no time limit	-45	+45	V
V <sub>digIO</sub>	DC voltage at digital IO pins (EN1B, EN2B, Rint, Rx0, Text, Tx0)		-0.3	V <sub>CC</sub> + 0.3	V
V <sub>REF</sub>	DC voltage at pin V <sub>REF</sub>		-0.3	V <sub>CC</sub> + 0.3	V
V <sub>tran(CANHx)</sub>	Transient voltage at pin CANH1/2	(Note 4)	-150	+150	V
V <sub>tran(CANLx)</sub>	Transient voltage at pin CANL1/2	(Note 4)	-150	+150	V
V <sub>esd(CANLx/CANHx)</sub>	ESD voltage at CANH1/2 and CANL1/2 pins	(Note 5) (Note 7)	-4 -500	+4 +500	kV V
V <sub>esd</sub>	ESD voltage at all other pins	(Note 5) (Note 7)	-2 -250	+2 +250	kV V
Latch-up	Static latch-up at all pins	(Note 6)		100	mA
T <sub>stg</sub>	Storage temperature		-55	+155	°C
T <sub>amb</sub>	Ambient temperature		-40	+125	°C
T <sub>junc</sub>	Maximum junction temperature		-40	+150	°C

4. Applied transient waveforms in accordance with "ISO 7637 part 3", test pulses 1, 2, 3a, and 3b (see Figure 5).
5. Standardized human body model (HBM) ESD pulses in accordance to MIL883 method 3015. Supply pin 8 is ±2 kV.
6. Static latch-up immunity: static latch-up protection level when tested according to EIA/JESD78.
7. Standardized charged device model ESD pulses when tested according to EOS/ESD DS5.3-1993.

# AMIS-42700

**Table 5. Thermal Characteristics**

Symbol	Parameter	Conditions	Value	Unit
$R_{th(vj-a)}$	Thermal resistance from junction to ambient in SO20 package	In free air	85	K/W
$R_{th(vj-s)}$	Thermal resistance from junction to substrate of bare die	In free air	45	K/W

**Table 6. DC and Timing Characteristics** ( $V_{CC} = 4.75$  to  $5.25$  V;  $T_{junc} = -40$  to  $+150^{\circ}C$ ;  $R_{LT} = 60$  W unless specified otherwise.)

Symbol	Parameter	Conditions	Min.	Typ.	Max.	Unit
<b>SUPPLY (pin V<sub>CC</sub>)</b>						
$I_{CC}$	Supply current, no loads on digital outputs, both busses enabled	Dominant transmitted Recessive transmitted		45	137.5 19.5	mA
PORL_VCC	Power-on-reset level on V <sub>CC</sub>		2.2		4.7	V
<b>DIGITAL INPUTS (Tx0, Text, EN1B, EN2B)</b>						
$V_{IH}$	High-level input voltage		$0.7 \times V_{CC}$	-	$V_{CC}$	V
$V_{IL}$	Low-level input voltage		-0.3	-	$0.3 \times V_{CC}$	V
$I_{IH}$	High-level input current	$V_{IN} = V_{CC}$	-5	0	+5	μA
$I_{IL}$	Low-level input current	$V_{IN} = 0$ V	-75	-200	-350	μA
$C_i$	Input capacitance	Not tested	-	5	10	pF
<b>DIGITAL OUTPUTS (pin Rx0, Rint)</b>						
$I_{oh}$	High-level output current	$V_o = 0.7 \times V_{CC}$	-5	-10	-15	mA
$I_{ol}$	Low-level output current	$V_o = 0.3 \times V_{CC}$	5	10	15	mA
<b>REFERENCE VOLTAGE OUTPUT (pin V<sub>REF1</sub>)</b>						
$V_{REF}$	Reference output voltage	$-50 \mu A < I_{VREF} < +50 \mu A$	$0.45 \times V_{CC}$	$0.50 \times V_{CC}$	$0.55 \times V_{CC}$	V
$V_{REF\_CM}$	Reference output voltage for full common mode range	$-35 V < V_{CANHx} < +35 V$ ; $-35 V < V_{CANLx} < +35 V$	$0.40 \times V_{CC}$	$0.50 \times V_{CC}$	$0.60 \times V_{CC}$	V
<b>BUS LINES (pins CANH1/2 and CANL1/2)</b>						
$V_{o(reces)} (CANHx)$	Recessive bus voltage at pin CANH1/2	$V_{Tx0} = V_{CC}$ ; no load	2.0	2.5	3.0	V
$V_{o(reces)} (CANLx)$	Recessive bus voltage at pin CANL1/2	$V_{Tx0} = V_{CC}$ ; no load	2.0	2.5	3.0	V
$I_{o(reces)} (CANHx)$	Recessive output current at pin CANH1/2	$-35 V < V_{CANHx} < +35 V$ ; $0 V < V_{CC} < 5.25 V$	-2.5	-	+2.5	mA
$I_{o(reces)} (CANLx)$	Recessive output current at pin CANL1/2	$-35 V < V_{CANLx} < +35 V$ ; $0 V < V_{CC} < 5.25 V$	-2.5	-	+2.5	mA
$V_{o(dom)} (CANHx)$	Dominant output voltage at pin CANH1/2	$V_{Tx0} = 0$ V	3.0	3.6	4.25	V
$V_{o(dom)} (CANLx)$	Dominant output voltage at pin CANL1/2	$V_{Tx0} = 0$ V	0.5	1.4	1.75	V
$V_{o(dif)} (bus)$	Differential bus output voltage ( $V_{CANHx} - V_{CANLx}$ )	$V_{Tx0} = 0$ V; dominant; $42.5 \Omega < R_{LT} < 60 \Omega$	1.5	2.25	3.0	V
		$V_{TxD} = V_{CC}$ ; recessive; no load	-120	0	+50	mV
$I_{o(sc)} (CANHx)$	Short circuit output current at pin CANH1/2	$V_{CANHx} = 0$ V; $V_{Tx0} = 0$ V	-45	-70	-120	mA
$I_{o(sc)} (CANLx)$	Short circuit output current at pin CANL1/2	$V_{CANLx} = 36$ V; $V_{Tx0} = 0$ V (Note 8)	45	70	120	mA

8. Guaranteed by design for VBAT = 36 V; measured in production for VBAT = 7 V to avoid short-2-VBAT detection



# AMIS-42700

**Table 6. DC and Timing Characteristics** ( $V_{CC} = 4.75$  to  $5.25$  V;  $T_{junc} = -40$  to  $+150^{\circ}\text{C}$ ;  $R_{LT} = 60$  W unless specified otherwise.)

Symbol	Parameter	Conditions	Min.	Typ.	Max.	Unit
<b>BUS LINES (pins CANH1/2 and CANL1/2)</b>						
$V_{i(dif)}(th)$	Differential receiver threshold voltage	$-5\text{ V} < V_{CANLx} < +12\text{ V}$ ; $-5\text{ V} < V_{CANHx} < +12\text{ V}$ ; see Figure 6	0.5	0.7	0.9	V
$V_{ihcm(dif)}(th)$	Differential receiver threshold voltage for high common-mode	$-35\text{ V} < V_{CANLx} < +35\text{ V}$ ; $-35\text{ V} < V_{CANHx} < +35\text{ V}$ ; see Figure 6	0.3	0.7	1.05	V
$V_{i(dif)}(hys)$	Differential receiver input voltage hysteresis	$-35\text{ V} < V_{CANL} < +35\text{ V}$ ; $-35\text{ V} < V_{CANH} < +35\text{ V}$ ; see Figure 6	50	70	100	mV
$R_{i(cm)}(CANHx)$	Common-mode input resistance at pin CANH1/2		15	26	37	K $\Omega$
$R_{i(cm)}(CANLx)$	Common-mode input resistance at pin CANL1/2		15	26	37	K $\Omega$
$R_{i(cm)}(m)$	Matching between pin CANH1/2 and pin CANL1/2 common-mode input resistance	$V_{CANHx} = V_{CANLx}$	-3	0	+3	%
$R_{i(dif)}$	Differential input resistance		25	50	75	K $\Omega$
$C_{i(CANHx)}$	Input capacitance at pin CANH1/2	$V_{Tx0} = V_{CC}$ ; not tested		7.5	20	pF
$C_{i(CANLx)}$	Input capacitance at pin CANL1/2	$V_{Tx0} = V_{CC}$ ; not tested		7.5	20	pF
$C_{i(dif)}$	Differential input capacitance	$V_{Tx0} = V_{CC}$ ; not tested		3.75	10	pF
$I_{LI}(CANHx)$	Input leakage current at pin CANH1/2	$V_{CC} < \text{PORL\_VCC}$ ; $-5.25\text{ V} < V_{CANHx} < 5.25\text{ V}$	-350	170	350	$\mu\text{A}$
$I_{LI}(CANLx)$	Input leakage current at pin CANL1/2	$V_{CC} < \text{PORL\_VCC}$ ; $-5.25\text{ V} < V_{CANLx} < 5.25\text{ V}$	-350	170	350	$\mu\text{A}$
$V_{CM-peak}$	Common-mode peak during transition from dom $\rightarrow$ rec or rec $\rightarrow$ dom	see Figure 10	-1000		1000	mV
$V_{CM-step}$	Difference in common-mode between dominant and recessive state	see Figure 10	-250		250	mV
$V_{CANL2VBAT}$	Detection level for CANL1/2 short to VBAT		7		9.5	V

### THERMAL SHUTDOWN

$T_{j(sd)}$	Shutdown junction temperature		150			$^{\circ}\text{C}$
-------------	-------------------------------	--	-----	--	--	--------------------

### TIMING CHARACTERISTICS (see Figures 7 and 8)

$t_d(Tx-BUSon)$	Delay Tx0/Text to bus active		40	85	120	ns
$t_d(Tx-BUSoff)$	Delay Tx0/Text to bus inactive		30	60	115	ns
$t_d(BUSon-Rx)$	Delay bus active to Rx0/Rint		25	55	115	ns
$t_d(BUSoff-Rx)$	Delay bus inactive to Rx0/Rint		65	100	145	ns
$t_d(ENxB)$	Delay from EN1B to bus active/inactive			100	200	ns
$t_d(Tx-Rx)$	Delay from Tx0 to Rx0/Rint and from Text to Rx0 (direct logical path)	15 pF on the digital output	4	10	35	ns
$t_d(CAN2VBAT)$	Reaction time of the CANL-to-VBAT short detector	Short occurring	1		4	$\mu\text{s}$
		Short disappearing	1		5.5	$\mu\text{s}$
$t_{dom}$	Time out counter interval		250	450	750	$\mu\text{s}$
$t_d(FBS)$	Delay for feedback suppression release		5+		330	ns

8. Guaranteed by design for VBAT = 36 V; measured in production for VBAT = 7 V to avoid short-2-VBAT detection

# AMIS-42700

## Measurement Set-ups and Definitions

Schematics are given for single CAN transceiver.

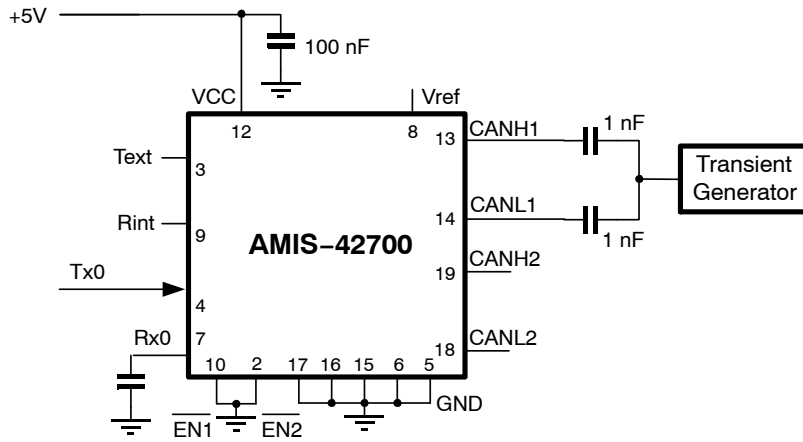

Figure 5. Test Circuit for Automotive Transients

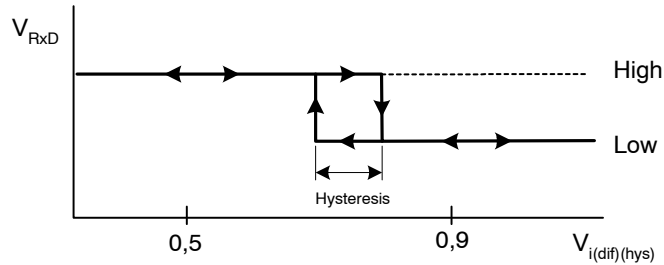

Figure 6. Hysteresis of the Receiver

# AMIS-42700

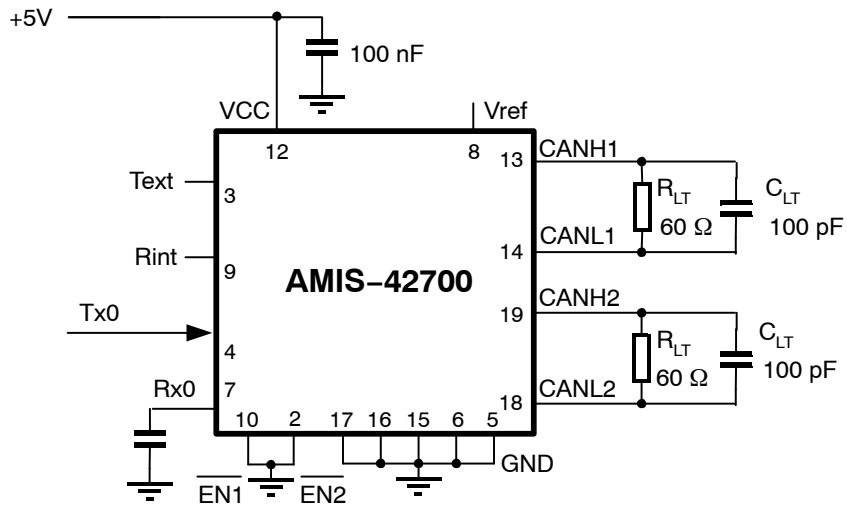

Figure 7. Test Circuit for Timing Characteristics

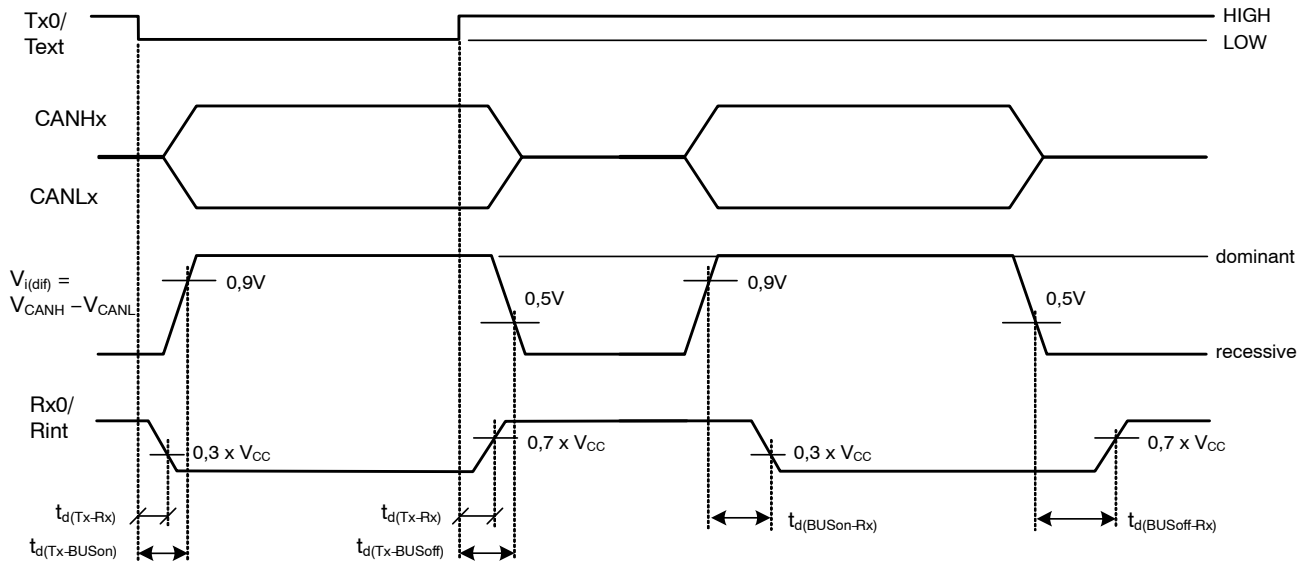

Figure 8. Timing Diagram for AC Characteristics

# AMIS-42700

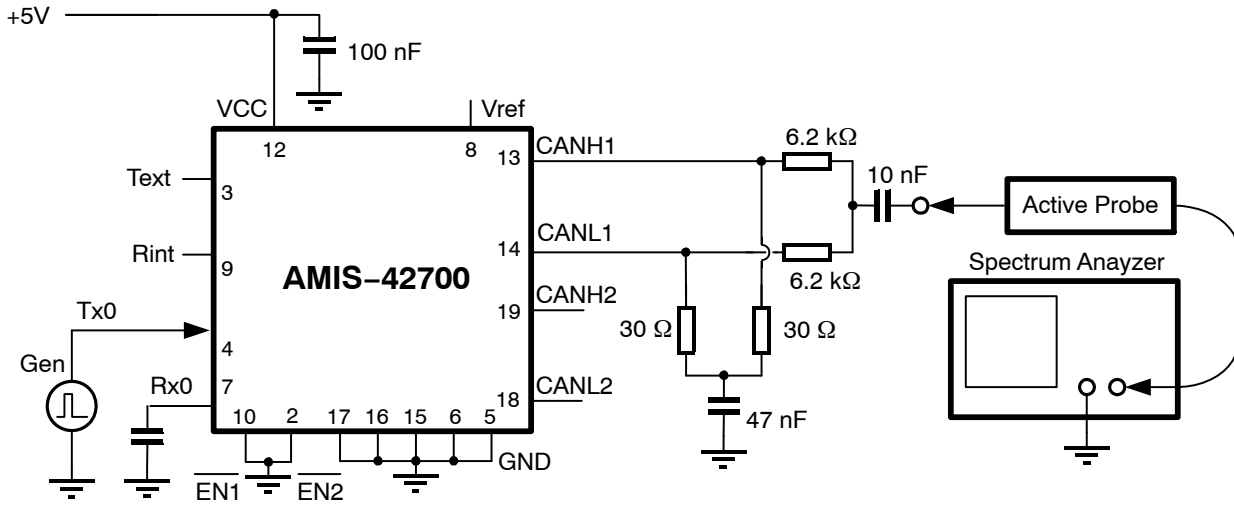

Figure 9. Basic Test Set-up for Electromagnetic Measurement

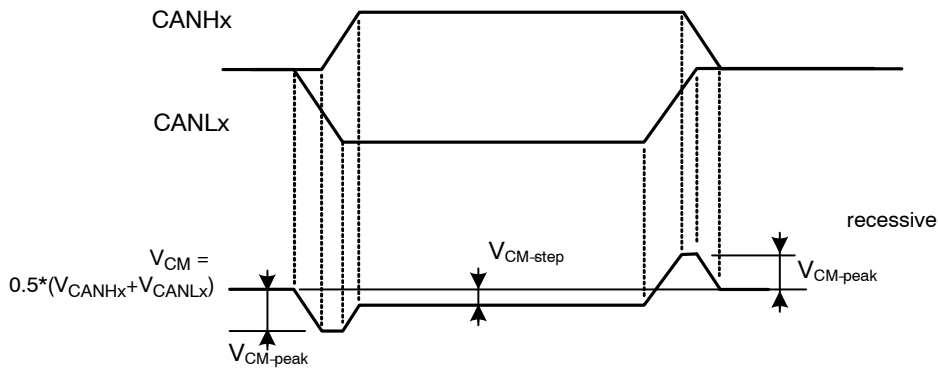

Figure 10. Common-mode Voltage Peaks (see measurement set-up Figure 9)

## ORDERING INFORMATION

Part Number	Package	Container		Temperature Range
		Shipping Configuration	Quantity	
AMIS42700WCGA4H	SOIC 150 20 300 GREEN	Rail	38	-40°C to 125°C
AMIS42700WCGA4RH	SOIC 150 20 300 GREEN	Tape & Reel	1500	-40°C to 125°C

**Soldering**

**Introduction to Soldering Surface Mount Packages**

This text gives a very brief insight to a complex technology. A more in-depth account of soldering ICs can be found in the ON Semiconductor “Data Handbook IC26; Integrated Circuit Packages” (document order number 9398 652 90011). There is no soldering method that is ideal for all surface mount IC packages. Wave soldering is not always suitable for surface mount ICs, or for printed-circuit boards with high population densities. In these situations reflow soldering is often used.

**Re-flow Soldering**

Re-flow soldering requires solder paste (a suspension of fine solder particles, flux and binding agent) to be applied to the printed-circuit board by screen printing, stenciling or pressure-syringe dispensing before package placement. Several methods exist for re-flowing; for example, infrared/convection heating in a conveyor type oven. Throughput times (preheating, soldering and cooling) vary between 100 and 200 seconds depending on heating method. Typical re-flow peak temperatures range from 215°C to 260°C.

**Wave Soldering**

Conventional single wave soldering is not recommended for surface mount devices (SMDs) or printed-circuit boards with a high component density, as solder bridging and non-wetting can present major problems. To overcome these problems the double-wave soldering method was specifically developed.

If wave soldering is used the following conditions must be observed for optimal results:

- Use a double-wave soldering method comprising a turbulent wave with high upward pressure followed by a smooth laminar wave.
- For packages with leads on two sides and a pitch (e):
  - Larger than or equal to 1.27 mm, the footprint longitudinal axis is preferred to be parallel to the transport direction of the print-circuit board;
  - Smaller than 1.27 mm, the footprint longitudinal axis must be parallel to the transport direction of the printed-circuit board. The footprint must incorporate solder thieves at the downstream end.
- For packages with leads on four sides, the footprint must be placed at a 45° angle to the transport direction of the printed-circuit board. The footprint must incorporate solder thieves downstream and at the side corners.
 

During placement and before soldering, the package must be fixed with a droplet of adhesive. The adhesive can be applied by screen printing, pin transfer or syringe dispensing. The package can be soldered after the adhesive is cured. Typical dwell time is four seconds at 250°C. A mildly-activated flux will eliminate the need for removal of corrosive residues in most applications.

**Manual Soldering**

Fix the component by first soldering two diagonally-opposite end leads. Use a low voltage (24 V or less) soldering iron applied to the flat part of the lead. Contact time must be limited to 10 seconds at up to 300°C.

When using a dedicated tool, all other leads can be soldered in one operation within two to five seconds between 270°C and 320°C.

**Table 7. Soldering Process**

Package	Soldering Method	
	Wave	Re-flow (Note 9)
BGA, SQFP	Not suitable	Suitable
HLQFP, HSQFP, HSOP, HTSSOP, SMS	Not suitable (Note 10)	Suitable
PLCC (Note 11), SO, SOJ	Suitable	Suitable
LQFP, QFP, TQFP	Not recommended (Notes 11 and 12)	Suitable
SSOP, TSSOP, VSO	Not recommended (Note 13)	Suitable

9. All SMD packages are moisture sensitive. Depending upon the moisture content, the maximum temperature (with respect to time) and body size of the package, there is a risk that internal or external package cracks may occur due to vaporization of the moisture in them (the so called popcorn effect). For details, refer to the dry pack information in the “Data Handbook IC26; Integrated Circuit Packages; Section: Packing Methods”.
10. These packages are not suitable for wave soldering as a solder joint between the printed-circuit board and heatsink (at bottom version) can not be achieved, and as solder may stick to the heatsink (on top version).
11. If wave soldering is considered, then the package must be placed at a 45° angle to the solder wave direction. The package footprint must incorporate solder thieves downstream and at the side corners.
12. Wave soldering is only suitable for LQFP, TQFP and QFP packages with a pitch (e) equal to or larger than 0.8 mm; it is definitely not suitable for packages with a pitch (e) equal or smaller than 0.65 mm.
13. Wave soldering is only suitable for SSOP and TSSOP packages with a pitch (e) equal to or larger than 0.65 mm; it is definitely not suitable for packages with a pitch (e) equal to or smaller than 0.5 mm.

# AMIS-42700

## PACKAGE DIMENSIONS

SOIC 20 W  
CASE 751AQ-01  
ISSUE O

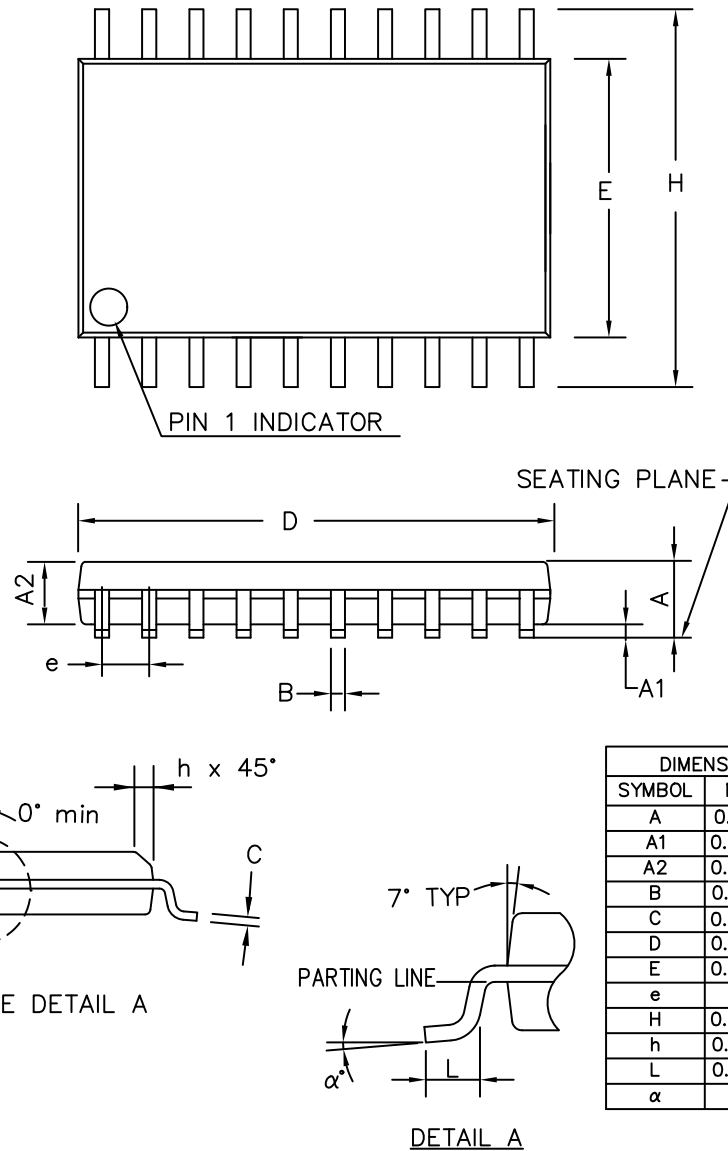

DIMENSIONS IN INCHES			
SYMBOL	MIN.	NOM.	MAX.
A	0.093	0.099	0.104
A1	0.004	0.008	0.012
A2	0.088	0.094	0.100
B	0.013	0.016	0.020
C	0.0090	0.0100	0.0125
D	0.496	0.503	0.510
E	0.292	0.296	0.299
e	.050 BSC.		
H	0.394	0.402	0.419
h	0.010	0.015	0.019
L	0.016	0.033	0.050
α	0°	5°	8°

**ON Semiconductor** and  are registered trademarks of Semiconductor Components Industries, LLC (SCILLC). SCILLC reserves the right to make changes without further notice to any products herein. SCILLC makes no warranty, representation or guarantee regarding the suitability of its products for any particular purpose, nor does SCILLC assume any liability arising out of the application or use of any product or circuit, and specifically disclaims any and all liability, including without limitation special, consequential or incidental damages. "Typical" parameters which may be provided in SCILLC data sheets and/or specifications can and do vary in different applications and actual performance may vary over time. All operating parameters, including "Typicals" must be validated for each customer application by customer's technical experts. SCILLC does not convey any license under its patent rights nor the rights of others. SCILLC products are not designed, intended, or authorized for use as components in systems intended for surgical implant into the body, or other applications intended to support or sustain life, or for any other application in which the failure of the SCILLC product could create a situation where personal injury or death may occur. Should Buyer purchase or use SCILLC products for any such unintended or unauthorized application, Buyer shall indemnify and hold SCILLC and its officers, employees, subsidiaries, affiliates, and distributors harmless against all claims, costs, damages, and expenses, and reasonable attorney fees arising out of, directly or indirectly, any claim of personal injury or death associated with such unintended or unauthorized use, even if such claim alleges that SCILLC was negligent regarding the design or manufacture of the part. SCILLC is an Equal Opportunity/Affirmative Action Employer. This literature is subject to all applicable copyright laws and is not for resale in any manner.

### PUBLICATION ORDERING INFORMATION

**LITERATURE FULFILLMENT:**  
Literature Distribution Center for ON Semiconductor  
P.O. Box 5163, Denver, Colorado 80217 USA  
**Phone:** 303-675-2175 or 800-344-3860 Toll Free USA/Canada  
**Fax:** 303-675-2176 or 800-344-3867 Toll Free USA/Canada  
**Email:** orderlit@onsemi.com

**N. American Technical Support:** 800-282-9855 Toll Free  
USA/Canada  
**Europe, Middle East and Africa Technical Support:**  
Phone: 421 33 790 2910  
**Japan Customer Focus Center**  
Phone: 81-3-5773-3850

**ON Semiconductor Website:** [www.onsemi.com](http://www.onsemi.com)  
**Order Literature:** <http://www.onsemi.com/orderlit>  
For additional information, please contact your local Sales Representative



Компания «ЭлектроПласт» предлагает заключение долгосрочных отношений при поставках импортных электронных компонентов на взаимовыгодных условиях!

Наши преимущества:

- Оперативные поставки широкого спектра электронных компонентов отечественного и импортного производства напрямую от производителей и с крупнейших мировых складов;
- Поставка более 17-ти миллионов наименований электронных компонентов;
- Поставка сложных, дефицитных, либо снятых с производства позиций;
- Оперативные сроки поставки под заказ (от 5 рабочих дней);
- Экспресс доставка в любую точку России;
- Техническая поддержка проекта, помощь в подборе аналогов, поставка прототипов;
- Система менеджмента качества сертифицирована по Международному стандарту ISO 9001;
- Лицензия ФСБ на осуществление работ с использованием сведений, составляющих государственную тайну;
- Поставка специализированных компонентов (Xilinx, Altera, Analog Devices, Intersil, Interpoint, Microsemi, Aeroflex, Peregrine, Syfer, Eurofarad, Texas Instrument, Miteq, Cobham, E2V, MA-COM, Hittite, Mini-Circuits, General Dynamics и др.);

Помимо этого, одним из направлений компании «ЭлектроПласт» является направление «Источники питания». Мы предлагаем Вам помощь Конструкторского отдела:

- Подбор оптимального решения, техническое обоснование при выборе компонента;
- Подбор аналогов;
- Консультации по применению компонента;
- Поставка образцов и прототипов;
- Техническая поддержка проекта;
- Защита от снятия компонента с производства.



#### Как с нами связаться

**Телефон:** 8 (812) 309 58 32 (многоканальный)

**Факс:** 8 (812) 320-02-42

**Электронная почта:** [org@eplast1.ru](mailto:org@eplast1.ru)

**Адрес:** 198099, г. Санкт-Петербург, ул. Калинина, дом 2, корпус 4, литера А.