

COOPER Bussmann



TRANSPORTATION PRODUCTS

Solutions for the Transportation Industry

Circuit Protection • Power Distribution • Wiring Accessories

Contents

	Page
Custom Solutions for Power Distribution	1
SERIES 31000/32000	
Vehicle Electrical Centers	2-3
Vehicle Electrical Center Connectors	4
Vehicle Electrical Center Accessories	5
SERIES 15300 RTMR	
Rear Terminal Mini Fuse & Relay Panels	6-7
SERIES 37700 PRM/PFM	
Power Relay Module/Power Fuse Module	8-9
SERIES 15710 RTA	
Rear Terminal ATC® Fuse Block	10
SERIES 15600	
ATC® Blade-Type Fuse Panels	11
HMG	
Automotive Bolt-In Fuseholder for the AMG Fuse	12
FMG	
Automotive Bolt-In Fuseholder for the AMG Fuse	13
Inline Fuseholders	14
SERIES 15250	
Battery Disconnect Switch	15
Stud Type Junction Blocks	16
Stud Type Junction Blocks (Non-Feed-Thru)	17
Basic Overcurrent Technology	18-19
MINI Blade Fuses	20
SERIES 21X MINI Circuit Breakers	21
ATC® Blade Fuses	22
SERIES 22X ATC® Circuit Breakers	23
SERIES 227 ATC® Circuit Breakers (Low Profile)	24
MAXI® Blade Fuses	25
SERIES 19X MAXI® Circuit Breakers	26
SERIES 3200/32013	
Insertion/Extraction Tool	27
SERIES 174 FLAT-PAK	
Manual Reset Circuit Breakers	28-29
SERIES 12X SHORTSTOP®	
Auto, Manual & Modified Reset Circuit Breakers	30
SERIES 25X MID-RANGE	
Auto, Manual Reset, & Manual Reset w/ Push-to-Trip Circuit Breakers	31
SERIES 18X HI-AMP	
Auto, Manual Reset & Switchable Circuit Breakers	32
SERIES 187 MRCB	
Switchable Circuit Breakers	33
AMI SERIES	
Bolt In Automotive Fuses	34
AMG SERIES	
Bolt In Automotive Fuses	35
NOTES	36-37



Custom Solutions For Power Distribution

Cooper Bussmann plays a key role in developing custom solutions for vehicle power distribution applications.

Once a product need is identified, an innovative team of design engineers works closely with the customer to discuss their needs. This enables our team to design and develop custom solutions tailored to meet specific customer requirements.

Many custom solutions include developing linkage systems to join two or more of our products together. This allows the customer “one-stop shopping” to create their vehicle electrical system. Other examples include bussing/jumpering, color-coding, and changing thread sizes.

If you are in need of a custom solution, please contact your Bussmann sales representative for assistance.

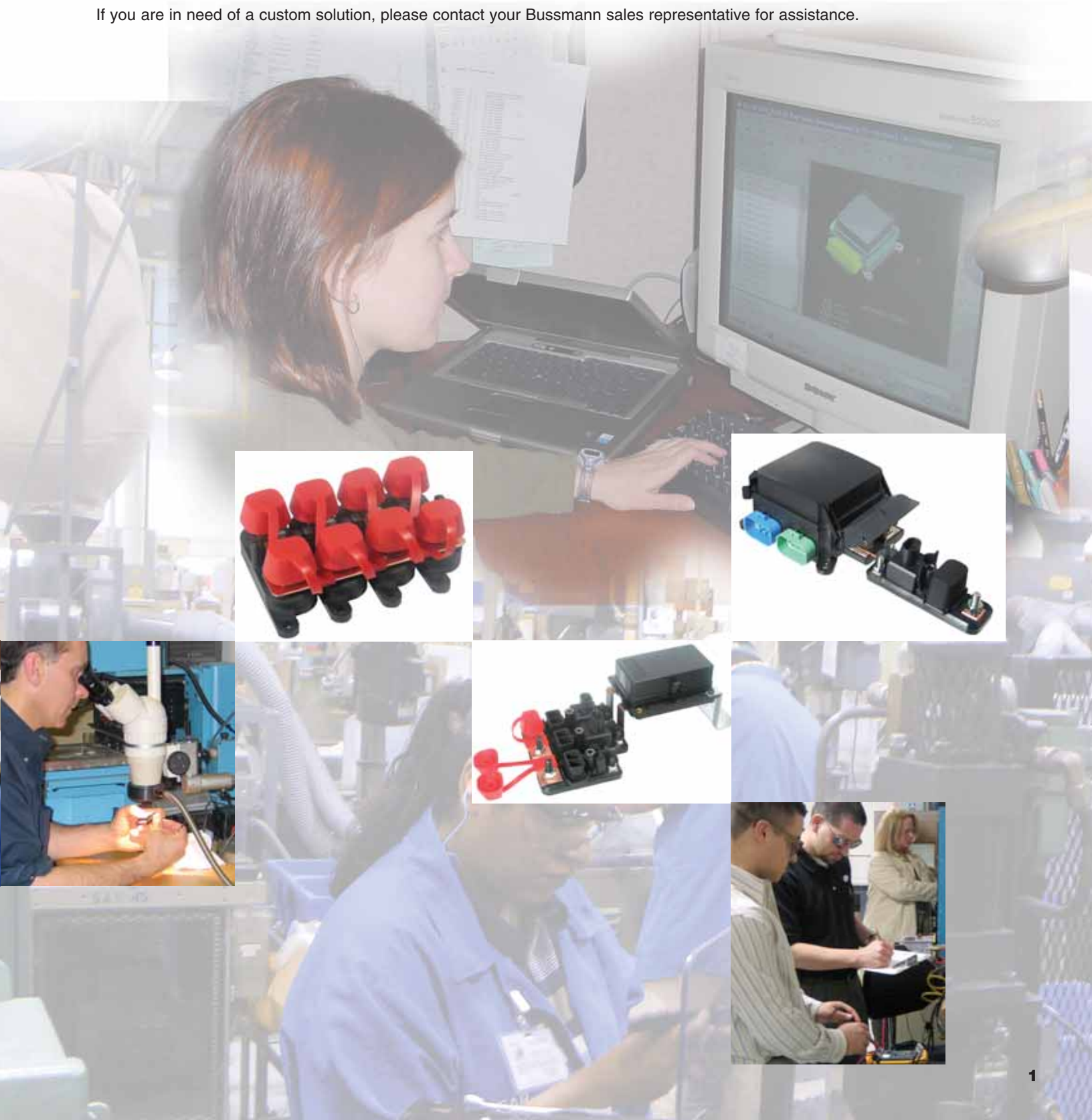

SERIES 31000/32000 VEHICLE ELECTRICAL CENTERS

Cooper Bussmann's Single Vehicle Electrical Center (VEC) and Dual Vehicle Electrical Center (DVEC) are widely used Transportation Industry power distribution modules. The VEC & DVEC use patented programmable 3D matrix technologies that can be easily modified to accommodate changes to an electrical system. These can be customized for each specific electrical system, but require no tooling for implementation.

The VEC & DVEC accept automotive components including fuses, relays, circuit breakers, diodes, and other devices that have 2.8mm wide terminals on 8.1mm center-line spacing. (See page 5 for additional available components.) The compact size of the VEC (about 4"x4") and larger size of the DVEC (approximately 8"x4") provide for high component density. VEC's provide either 8.0mm bladed inputs or M8/M6 stud inputs. The VEC can accommodate up to 2 input connectors - 4 bladed inputs or 2 studs - and 4 output connectors. The DVEC can accommodate up to twice this amount. (Some designs may limit the number of connectors available for use.)

SPECIFICATIONS

Input Terminal Rating: 8.0mm blade terminals (60A max per terminal); M8/M6 input studs (100A max per terminal). 200A max total for VEC, 400A max total for DVEC.

Output Terminal Rating: 2.8mm blade terminals (30A max per terminal).

Temperature Rating: -40°F (-40°C) to 260°F (125°C).

Materials: Thermoplastic housing and connectors; Tin-plated copper internal grid.

Termination: Delphi Packard Metri-Pack® 280 Series terminals (sealed/unsealed & tanged/tangless) or AMP® terminals.* Delphi Packard 280 Series cavity plugs are installed where wires are not used.* Accepts #10-22 AWG wire sizes.

Mounting Torque Rating: 24in-lb (2.7Nm) max.

Mounting Orientation: Unit cannot be installed upside-down. Consult factory for proper mounting orientations.

Ingress Protection Rating: IP55.

OPTIONS

Cover: Vented (VEC), Solid with gasket (VEC/DVEC), Solid without gasket (DVEC), or none provided.

Cover Label: Inside cover, outside cover (VEC only), or none provided.

Input Style: 8.0mm blade terminals or studs (M8/M6).

Mounting: External feet with mounting holes (VEC/DVEC) or internal mounting holes (VEC only).

Components: Fuse, breaker, relay, etc. installation to be specified by customer.

Severe Service: Added environmental protection available. Consult factory.

Fuse/breaker Extraction Tool: See page 27.

Each design is customer specific. Consult your sales rep today for your application.

*Electrical terminals, cable seals & cavity plugs are NOT supplied by Cooper Bussmann.

APPLICATIONS

The VEC/DVEC is ideal for distributed main power as well as auxiliary "add-on" applications. Current VEC/DVEC applications include Class 3-8 trucks, buses, chassis and RV, Con-Ag equipment, marine specialty vehicles, and automotive power distribution systems.

BENEFITS

The customizable designs of the VEC/DVEC enable them to incorporate many different devices and multiple design variations. Splices in the harness can also be eliminated by internally programming them into the grid matrix. The inputs (connector or stud) and outputs (connector) of the VEC/DVEC are color-coded and keyed, and provide quick installation. This makes the module easy to service. The largest benefit of these modules are the reduced lead times and **zero** tooling cost.



Transparent cover for illustration purposes only.



SERIES 31000/32000 VEHICLE ELECTRICAL CENTERS

DIMENSIONS 31000 SERIES VEC (Dims. shown are for reference only. Consult factory for latest prints)

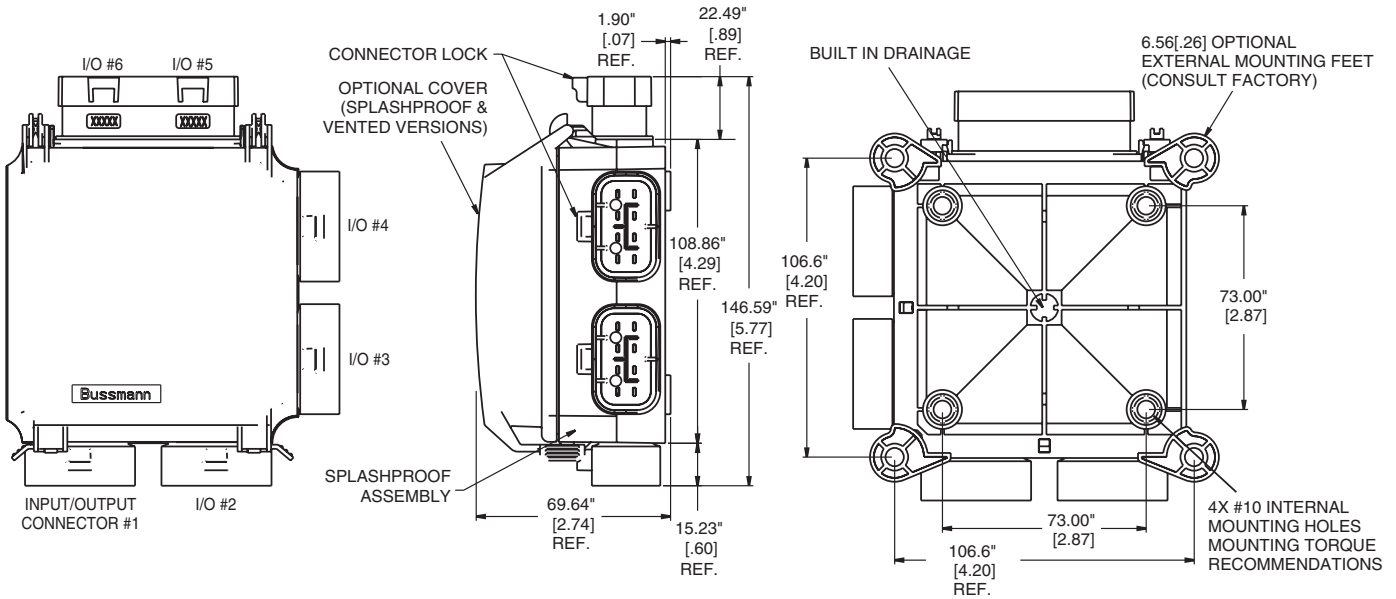

DIMENSIONS 32000 SERIES DVEC (Dims. shown are for reference only. Consult factory for latest prints)

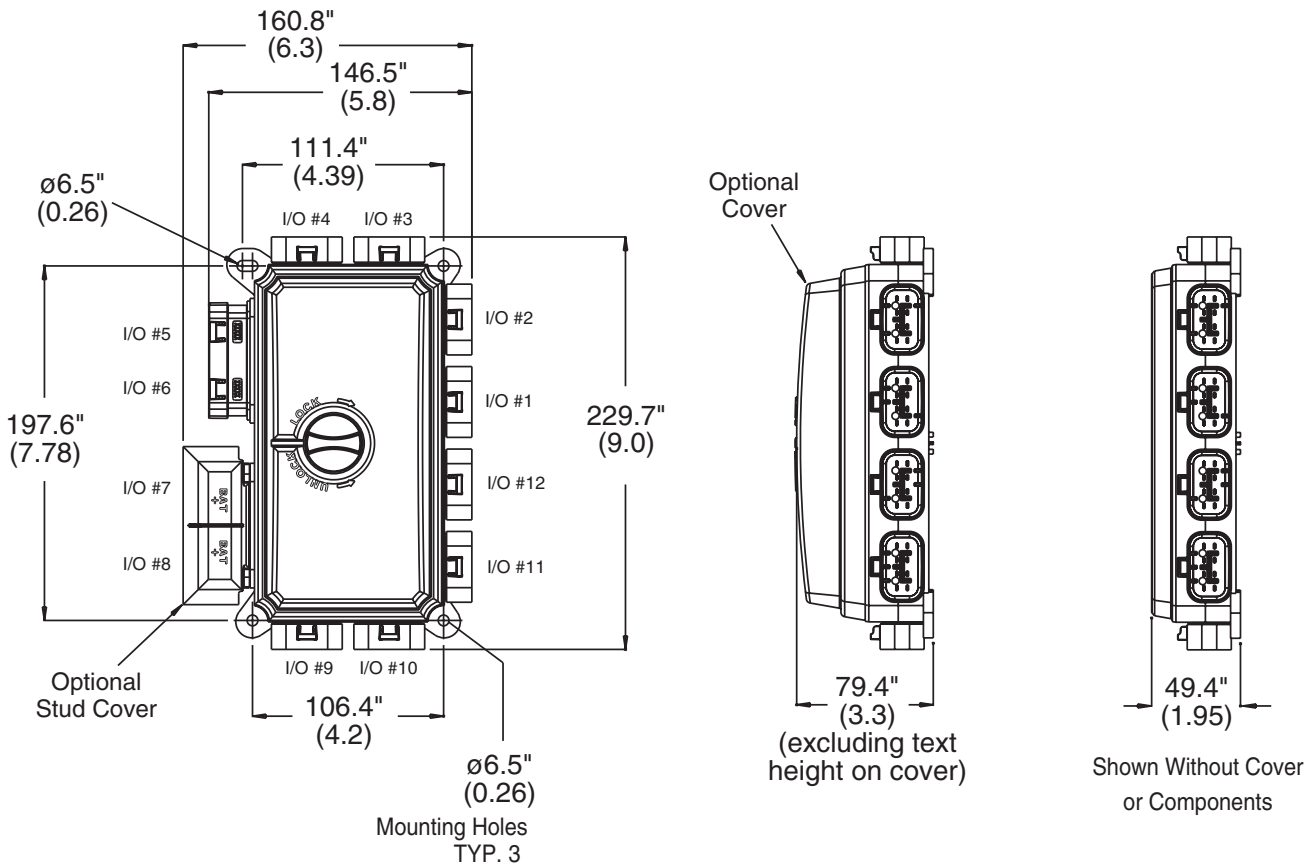

VEHICLE ELECTRICAL CENTER CONNECTORS

MALE INPUT CONNECTOR
32004 - X X

- Sealed / Non-Sealed Configuration
 - 1 = Non-Sealed Version
 - 2 = Sealed Version
- Color of Part
 - A = Black
 - B = Gray

TERMINAL POSITION ASSURANCE
32004 -TPX

- Sealed / Non-Sealed Configuration
 - 1 = Non-Sealed Version
 - 2 = Sealed Version

CONNECTOR POSITION ASSURANCE
32004 - CP (Ship in Bulk)

Note: Terminals and Terminal Seal Components are not provided with connectors. Available from Delphi Packard. Contact factory for part list and terminal removal tool. Sealed connector option includes outer body seal.

(Dims.shown are for reference only. Consult factory for latest prints)

MALE OUTPUT CONNECTOR
32006 - X X X

- Sealed / Non-Sealed Configuration
 - 1 = Non-Sealed Version
 - 2 = Sealed Version
- Connector Cavity Configuration
 - 1 = Tang-less Female Connector (Delphi 280)
 - 2 = with Tang Female Connector (Delphi 280)
 - 3 = AMP®
 - P = all cavities plugged
- Color of Part
 - A = Black
 - B = Gray
 - C = Green
 - D = Blue
 - E = Yellow
 - F = Red
 - G = Orange
 - H = Brown
 - J = Neutral (only available for -JP2 option)

TERMINAL POSITION ASSURANCE
32006 - TPX

- Sealed / Non-Sealed Configuration
 - 1 = Non-Sealed Version
 - 2 = Sealed Version

CONNECTOR POSITION ASSURANCE
32006 - CP (Ship in Bulk)

Note: Terminals and Terminal Seal Components are not provided with connectors. Available from Delphi Packard. Contact factory for part list and terminal removal tool. Sealed connector option includes outer body seal.

(Dims.shown are for reference only. Consult factory for latest prints)



Series 229 Diode, Resistor, and Transorb

SPECIFICATIONS (Dims. shown are for reference only. Consult factory for latest prints)

Ratings: Consult Factory for Available Ratings and part numbers

Materials: Grey 94V-0 thermoplastic housing with metal cover.

Termination Type: Compatible with 280 Type fuse blocks using 8.1mm centerline.

Diode Key Feature: Standard key denotes installation direction. Extended key available for error-proof installation in VEC.

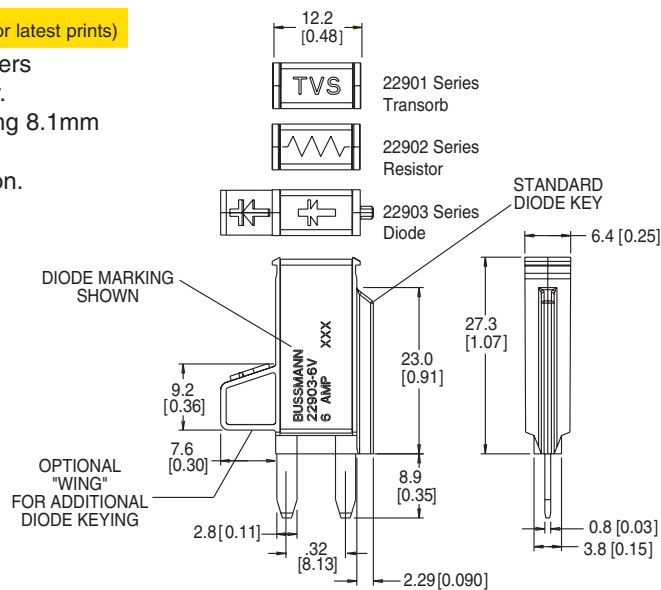

Relays (Only Available for VEC, DVEC, or RTMR Applications.)

SPECIFICATIONS

Types: 5-pin mini-relay, 12 VDC & 24 VDC

5-pin micro-relay, 12 VDC & 24 VDC

4-pin mini-micro relay, 12 VDC

Consult Factory for Available Amperage Ratings

Termination Type: Compatible with 280 Type fuse blocks using 8.1mm centerline.

Sealed versions of some relays also available.

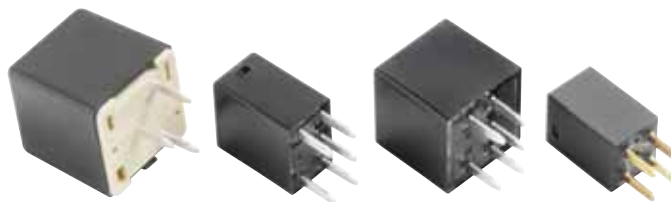

VEC ACCESSORIES

Series 32016 (Terminal Seals) & Series 32017 (Cavity Plugs)

Used in conjunction with the VEC input connector (Series 32004), terminal seals provide a sealed fit between the wire terminals and connector. Cavity plugs can be used to seal unused terminal positions.



Series 32011 (Input Connector Cap) & Series 32012 (Output Connector Cap)

Connector caps can be assembled to the mating VEC harness connectors (Series 32004 & 32006) when not in use.



DVEC Cover Tether

Tether available for use with Series 32000 DVEC cover. Consult factory.



Series 32018 (for use with Series 32000 DVEC)

External bus bar can be used with the Dual VEC to bus together studded power inputs.

SERIES 15300 RTMR

Rear Terminal Mini Fuse & Relay Power Distribution Module

NEW
IP66/67 Rated

The Rear Terminal Mini Fuse and Relay panel (RTMR) provides efficient power distribution in a rugged compact form for applications in marine, construction, agriculture, heavy trucking, specialty vehicles, etc. This innovative product offers a weather tight enclosure (**IP66/67**) for various MINI (2.8mm) blade components when cover, cable seals, and cavity plugs are installed. It is available with various degrees of internal electrical bussing. Additionally, custom labels and multiple hardware configurations are available to solve any application need.

SPECIFICATIONS

Input Terminal Rating: M6 input studs on bussed/partially bussed inputs: 80A max input on bussed fuse side, 80A max input on bussed relay side.

Output Terminal Rating: 2.8mm blade terminals (30A max per terminal)

Temperature Rating: -40°F (-40°C) to 260°F (125°C).

Materials: Black thermoplastic housing; Tin-plated copper internal bussing; Bright nickel-plated brass studs (on bussed versions).

Termination: Delphi Packard Metri-Pack® 280 Series terminals (sealed/tangless) or AMP® terminals.* Delphi Packard 280 Series cavity plugs are installed where wires are not used.* Accepts #12-22 AWG wire sizes.

Torque Rating: 75in-lb (8.5Nm) max.

Mounting Torque Rating: #10-32 or M5 threaded inserts; 24in-lb (2.7Nm) max torque.

Ingress Protection Rating: IP66-IEC 60529 (Valid when properly installed with cover, sealed terminals, and cavity plugs.) IP67 (Same requirements as IP66, but also needs a periodic - 3-9 months - coating of silicone lubricant applied to green base seal.)

OPTIONS

End Caps: Protective silicone end caps available for studed versions.

Mounting: Mounting brackets available for surface-mounting RTMR. (See page 7.)

Labels: Consult factory for custom label options.

Replacement Accessories: Consult factory for available service parts.

***Electrical terminals, cable seals & cavity plugs are NOT supplied by Cooper Bussmann.**



SERIES 15300 RTMR

DIMENSIONS (Dims. shown are for reference only. Consult factory for latest prints)

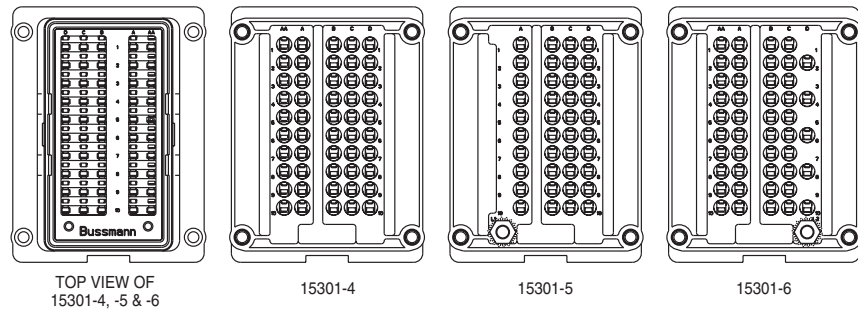
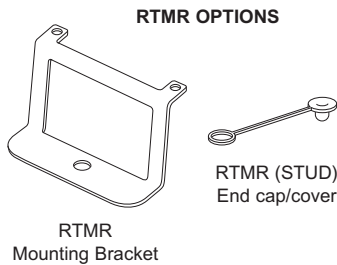
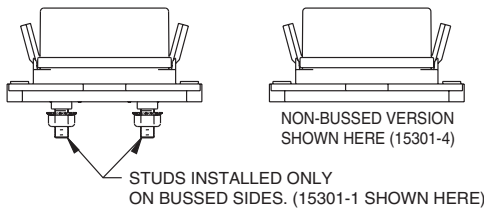
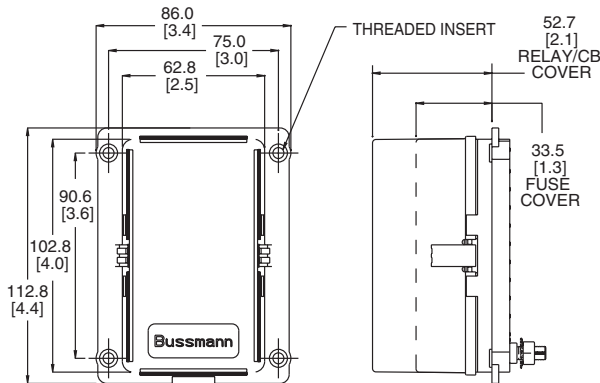

PART NUMBERING SYSTEM

Series	Mounting	Base	Terminal Cavity	Hardware	Cover	Marking Options
1530	—	□	□ —	□ —	□	□
1 – #10-32 threaded insert	1 – Fuse / C.B. Base 20 Fuse Positions (10 on each side)	Blank – Standard Delphi 280® A – AMP® series	0 – No nuts 1 – Nuts (bulk) 2 – Nuts (assembled) 3 – No nuts, end caps (bulk) 4 – No nuts, end caps (assembled) 5 – Nuts and end caps (in bulk) 6 – Nuts and end caps (assembled)	0 – No cover 1 – Fuse cover 2 – Relay / circuit breaker (C.B.) cover	Blank – Std. marking (Consult factory for special options.)	
2 – M5x0.8 threaded insert	2 – Micro Relay Base 5 Micro Relays with 10 Fuses / C.B.					
	3 – Mini Relay Base 3 Mini (or Micro) Relays with 10 Fuses / C.B.					
	4 – Non Bussed Version 3 Mini or 5 Micro Relays and 10 Fuses/C.B.					
	5 – Partially Bussed Version 3 Unbussed Mini or 5 Unbussed Micro Relays and 10 Bussed Fuses/C.B.					
	6 – Partially Bussed Version 3 Bussed Mini or 5 Bussed Micro Relays and 10 Unbussed Fuses/C.B.					

Mounting Brackets

B028 – 7012 – □

Material

O – Plated steel
P – Stainless steel

RTMR Stud End Cap

B066 – 7008

SERIES 37700 PRM/PFM



Power Relay Module Power Distribution Module & Fuse Block

Cooper Bussmann offers a **sealed** Power Relay Module (PRM) along with an accompanying Power Fuse Module (PFM). These compact power distribution modules are designed for high current applications, and are suitable for placement in extreme moisture and high vibration environments. The PRM contains a 70A relay and two female fuse positions. One of these fuses protects the relay and the other is a single-circuit inline fuse. The PFM contains only two fuses - each a separate circuit. A silicone seal and removable cover offer a weather-tight enclosure for the fuse positions. PRMs/PFMs also feature rugged M8 power input studs. Multiple units may be connected together via a custom buss bar, or can be bussed to any of Cooper Bussmann's PDMs (i.e. 31000/32000 Series VEC/DVEC, 15300 Series RTMR, etc.)



SPECIFICATIONS

PRM Rating: 70A, 12VDC steady-state relay; 24VDC relay also available. Relay protection fuse: up to 60A; Non-switched inline fuse: up to 60A.

PFM Rating: Each inline fuse rated up to 60A.

Temperature Rating: -40°F (-40°C) to 185°F (85°C).

Materials: UL-Rated 94V-0 thermoplastic (excluding cover); Silicone seal; Tin-plated copper terminals; Plated steel studs.

Input Termination: M8 threaded stud. PRM Switching/Trigger Signal: Delphi Packard Metri-Pack® 150 Series; AMPSEAL® 16.*

Output Termination Option: Bussmann Series 32004 sealed connector (see page 4); Accepts Delphi Packard 800 series terminals.* Two M6 threaded studs.

Torque Rating: Input stud: 144in-lb (16.3Nm) max.; Output stud: 48in-lb (5.4Nm) max.

Mounting Torque Rating: 48in-lb (5.4Nm) max.

Ingress Protection Rating: IP66 (excluding stud connections)

OPTIONS

Mounting: Counter rotation feature (CRF) available to prevent rotation on single bolt installations.

Bussing: Custom bussing available for joining multiple PRMs/PFMs. Options also available for bussing PRMs/PFMs to other Bussmann power distribution modules.

Accessories: Stud caps, separators, service components. Consult factory for details.

***Electrical terminals are NOT supplied by Cooper Bussmann.**

PART NUMBERING SYSTEM

Series/ Module Type	Output/Signal Connector Type	Signal Key (PRM only)	Output Key	Nonswitched Value	Switched Fuse (Right Side)	Cover Option	Hardware Option
37701	1	N					
PFM							
37702							
12V PRM							
37703							
24V PRM							
*1 - Stud/Delphi	A - Black (Delphi only)	N - Stud output (no key)	0 - None	2 - 20 amps	0 - None	0 - No cover	0 - None
2 - Connector/Delphi	B - Grey (AMP® or Delphi)	A - Black	3 - 30 amps	3 - 30 amps	2 - 20 amps	1 - Cover (bulk)	1 - Nuts (bulk)
3 - Stud/AMP®	C - Green (AMP® only)	B - Grey	4 - 40 amps	4 - 40 amps	3 - 30 amps	2 - Cover (installed)	2 - Nuts (installed)
4 - Connector/AMP®	F - Red (AMP® only)		5 - 50 amps	5 - 50 amps	4 - 40 amps		3 - CRF
	Y - Yellow (AMP® only)		6 - 60 amps	6 - 60 amps	5 - 50 amps		4 - CRF, nuts (bulk)
					6 - 60 amps		5 - CRF, nuts (installed)

*PFM always uses this option.

SERIES 37700 PRM/PFM (Dims. shown are for reference only. Consult factory for latest prints)

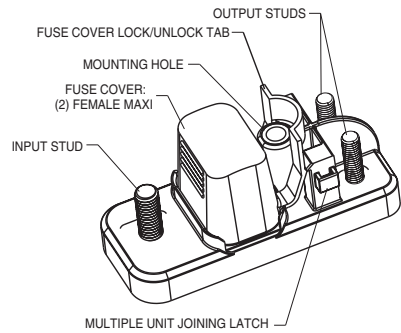
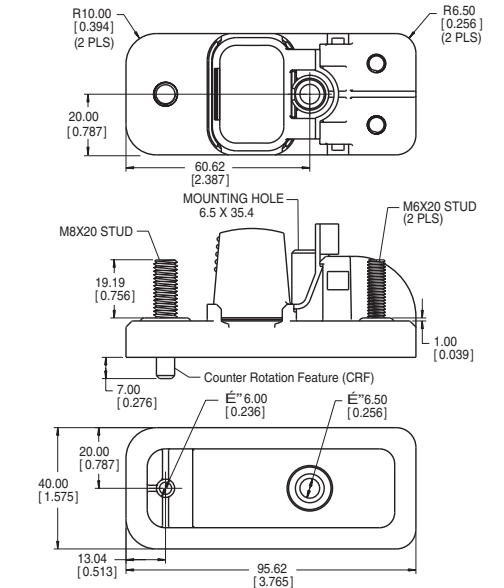
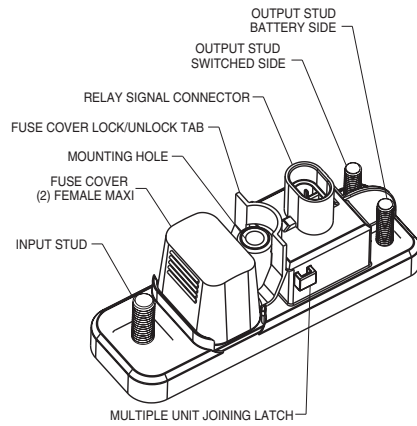
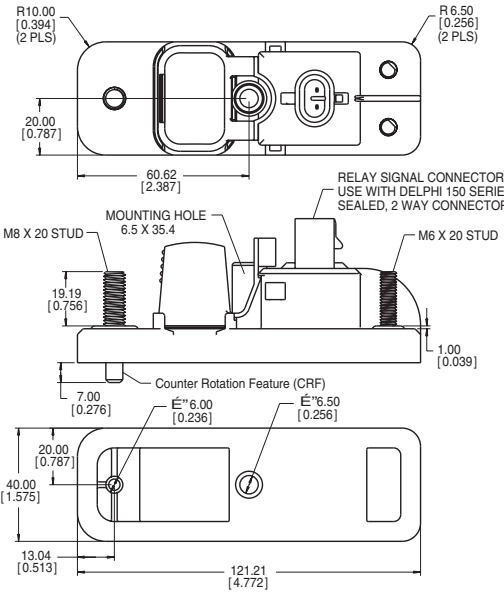
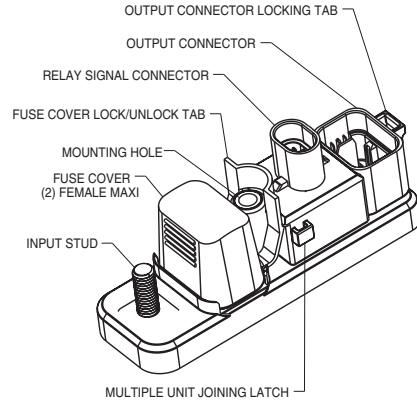
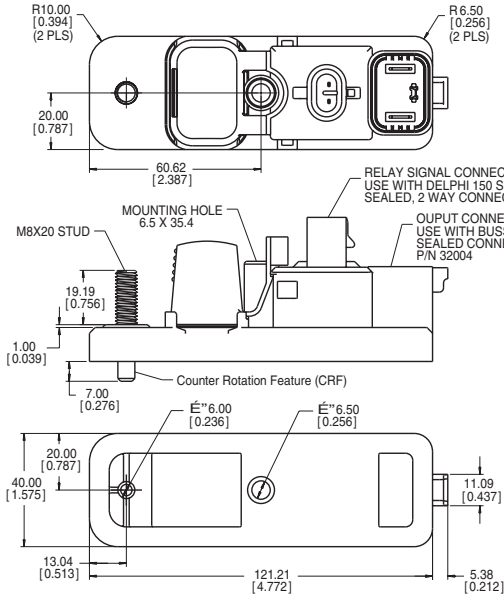

SERIES 15710 REAR TERMINAL ATC® FUSE BLOCK

The Rear Terminal ATC® Fuse Block (RTA) is a rear-fed panel with high component retention, which makes it an ideal choice for high vibration environments including construction, agriculture, bus, RV, heavy trucking equipment, etc. It is available in multiple lengths and internal bussing configurations. This allows for up to three separate power input circuits and 32 individual output circuits.



SPECIFICATIONS

- Input Terminal Rating:** 1/4-20 stud; Quick-connect terminals provided on middle bus (Series 15713). 200A max total input for unit.
- Output Terminal Rating:** 30A max load per circuit.
- Temperature Rating:** -40°F (-40°C) to 260°F (125°C).
- Materials:** Black thermoplastic.
- Termination:** Delphi Packard Pack-Con® Series 3 & 5.* Input Wire Size: #4-6 AWG. Output Wire Size: #10-16 AWG.
- Torque Rating:** 50in-lb (5.6Nm) max.
- Mounting Torque Rating:** #10-32 threaded inserts, 24in-lb (2.7Nm) max torque.

OPTIONS

- Positions:** 8-32 circuits available.
- Split Power:** Single, dual, or triple bus options.
- Cover:** Splash-resistant covers available. Short cover for fuses only, and taller cover for use with circuit breakers.
- Locks:** Secondary locks available for securing of output terminals (#15710-TP). (Comes in multiples of 8 positions. Must order multiple strips to cover length of selected RTA.)
- Tools:** Output terminal removal tool (#HT15710-01). Secondary lock removal tool (#HT15710-02).

*Electrical Terminals are NOT supplied by Cooper Bussmann.

DIMENSIONS (Dims. shown are for reference only. Consult factory for latest prints)

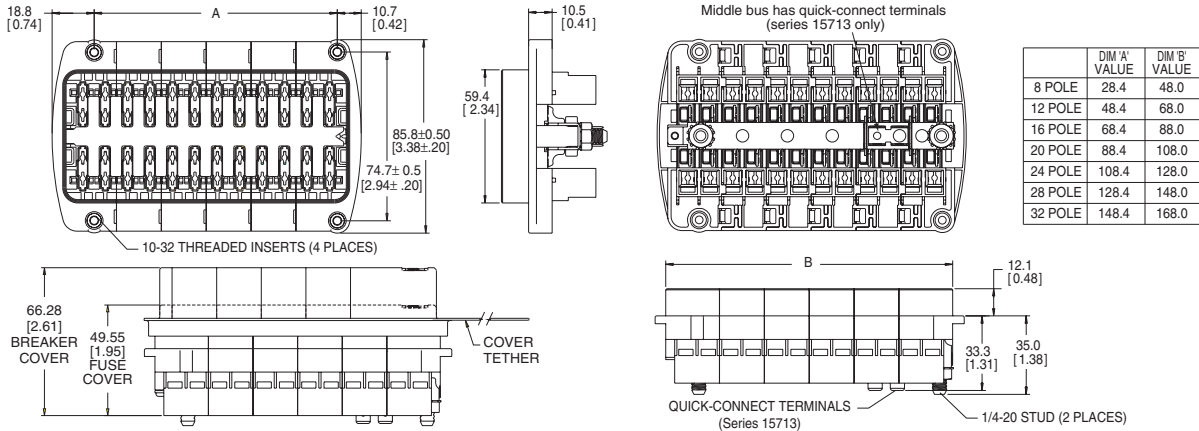

PART NUMBERING SYSTEM

Series	No. of Positions	Hardware Options	Cover Option	Marking Option
1	08-32	—	—	—
1 5 7 1	Left Side / Right Side 06-28 / 04-28 (max. tot 32) (increments of 4)	—	—	—
3	Total Pos / Left Side 14-32 / 06-24 (max. total of 32) (increments of 4)	—	—	—
1 – Single Stud, Single Supply Circuit 2 – Double Stud, Split Supply Circuit 3 – Triple Buss, Split Supply Circuit				
0 – W/O nuts 1 – Nuts shipped bulk 2 – Nuts assembled				
0 – No cover 1 – w/ fuse cover 2 – w/ CB cover				
A-Standard (consult factory for special marking)				

SERIES 15600 ATC® Blade-Type Fuse Panels



The 15600 ATC® fuse block is a compact, yet rugged, power distribution module. It is available in a single or dual internal buss electrical configuration featuring an optional ground pad terminal strip. The 15600 fuse block is surface mounted, uses convenient quick-connect terminals, and is recommended as a supplemental power distribution module. It can be used to accompany main PDMs such as the Bussmann 31000/32000 Series VEC/DVEC, 15710 Series RTA, and the 15301 Series RTMR.

SPECIFICATIONS

- Input Terminal Rating:** #10-32 threaded studs (100A max).
- Output Terminal Rating:** 30A max per circuit.
- Temperature Rating:** -20°F (0°C) to 150°F (65°C).
- Materials:** Black thermoplastic.
- Termination:** .250" x .032" quick-connect terminals.
- Ground terminal pad option available. Input wire size: #4-6 AWG. Output wire size: #12-16 AWG.
- Torque Rating:** 20in-lb (2.25Nm) max.
- Mounting Torque Rating:** 8in-lb (0.9Nm) max.

OPTIONS

- Positions:** 4-20 circuits available.
- Split Power:** Single or dual buss options.

DIMENSIONS (Dims. shown are for reference only. Consult factory for latest prints)

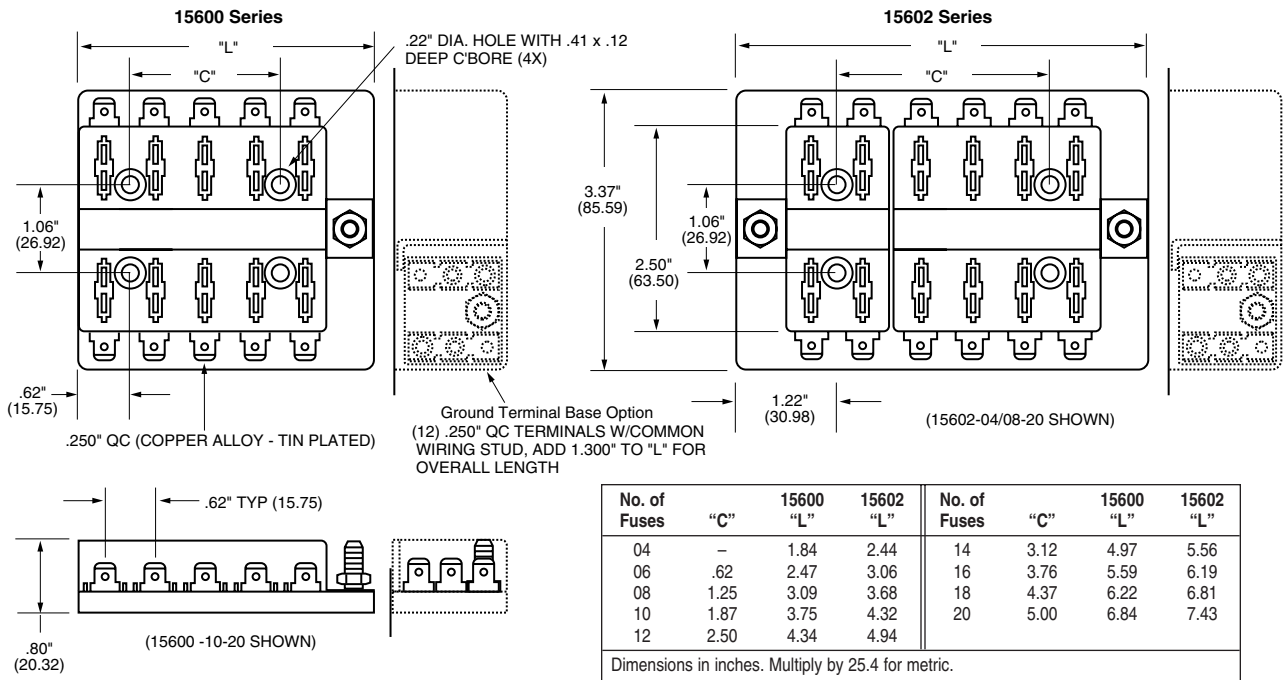

PART NUMBERING SYSTEM

Series	No. of Fuses &/or Circuit Breaker Positions	Hardware Options	Ground Terminal Base
0	□□	□	□
1560	04-20		
2	□□ / □□	□	□
0 - Single Stud, Single Supply Circuit	Left Side Right Side	0 - W/O nuts	0 - None
2 - Double Stud, Split Supply Circuits	04-16 04-16	1 - Nuts shipped bulk	1 - Include Ground Pad
	(max. combination of 20)	2 - Nuts assembled	

HMG FUSEHOLDER

Automotive Bolt-In Fuseholder for the AMG Fuse



The HMG fuse holder accepts industry standard AMG fuses for primary fusing applications. The narrow rugged body makes it ideal for demanding environments such as 'under the hood' locations in construction, agriculture, heavy trucking, and specialty vehicle applications.

SPECIFICATIONS

- Rating:** For use with AMG fuses from 100-300A.
- Temperature Rating:** -40°F (-40°C) to 260°F (125°C).
- Materials:** Black thermoplastic with zinc-plated steel studs.
- Termination:** M8 or 5/16-18 threaded studs and hex nuts for fuse mounting. Wire sizes: #2-8 AWG.
- Torque Rating:** 150in-lb (17Nm) max.
- Mounting Torque Rating:** Optional mounting hole patterns, 44in-lb (5Nm) max.

FEATURES

- Side-stackable
- Bottom side insulated from mounting panel.
- Splash resistant cover.

DIMENSIONS (Dims.shown are for reference only. Consult factory for latest prints)

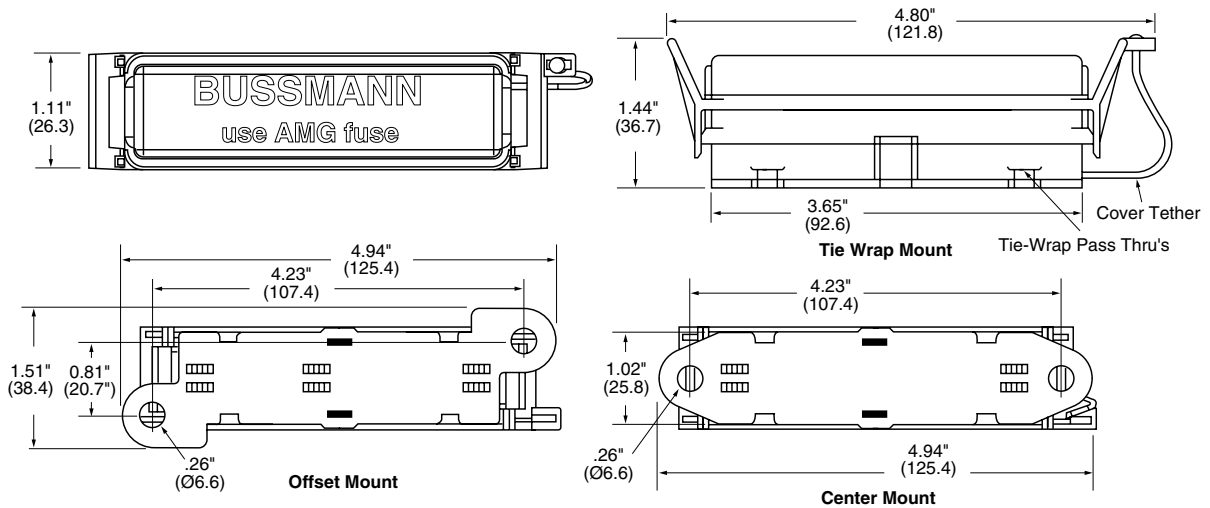

PART NUMBERING SYSTEM

Series	Base	Hardware	Style	Options
HMG	-			
	1 - Tie wrap mount 2 - Offset mounted 3 - Center mounted*	1 - 5/16-18 Studs w/nuts installed 2 - 5/16-18 Studs w/nuts bulk 3 - 5/16-18 Studs w/o nuts 4 - M8 x 1.25 studs w/nuts installed 5 - M8 x 1.25 studs w/nuts bulk 6 - M8 x 1.25 studs w/o nuts	0 - No cover 1 - Cover installed 2 - Cover bulk	Consult factory for Bus Bar options

*Consult factory for availability.

FMG FUSEHOLDER

Full Access Automotive Bolt-In Fuseholder for the AMG Fuse



The FMG fuse holder accepts industry standard AMG fuses for primary fusing applications. The FMG is offered with a tough elastomer cover for fuse protection, yet allows for cable input from various orientations. This fuse holder cover is available in multiple colors and lengths. Similar to Bussmann's HMG holder, the FMG is well suited for demanding environments such as 'under the hood' locations in construction, agriculture, heavy trucking, and specialty vehicle applications.

SPECIFICATIONS

- Rating:** For use with AMG fuses from 100-300A.
- Temperature Rating:** -40°F (-40°C) to 260°F (125°C).
- Materials:** Black thermoplastic with zinc-plated steel studs; thermoplastic elastomer cover.
- Termination:** M8 or 5/16-18 threaded studs and hex nuts for fuse mounting. Wire sizes: #2-8 AWG.
- Torque Rating:** 120in-lb (13.5Nm) max.
- Mounting Torque Rating:** 1/4-20 screws with washers (recommended), 44in-lb (5Nm) max.

OPTIONS

Cover: Available in black or red. Extended cover length also available.

FEATURES

Full access for cables. Can be routed to studs from nearly every direction.

DIMENSIONS (Dims.shown are for reference only. Consult factory for latest prints)

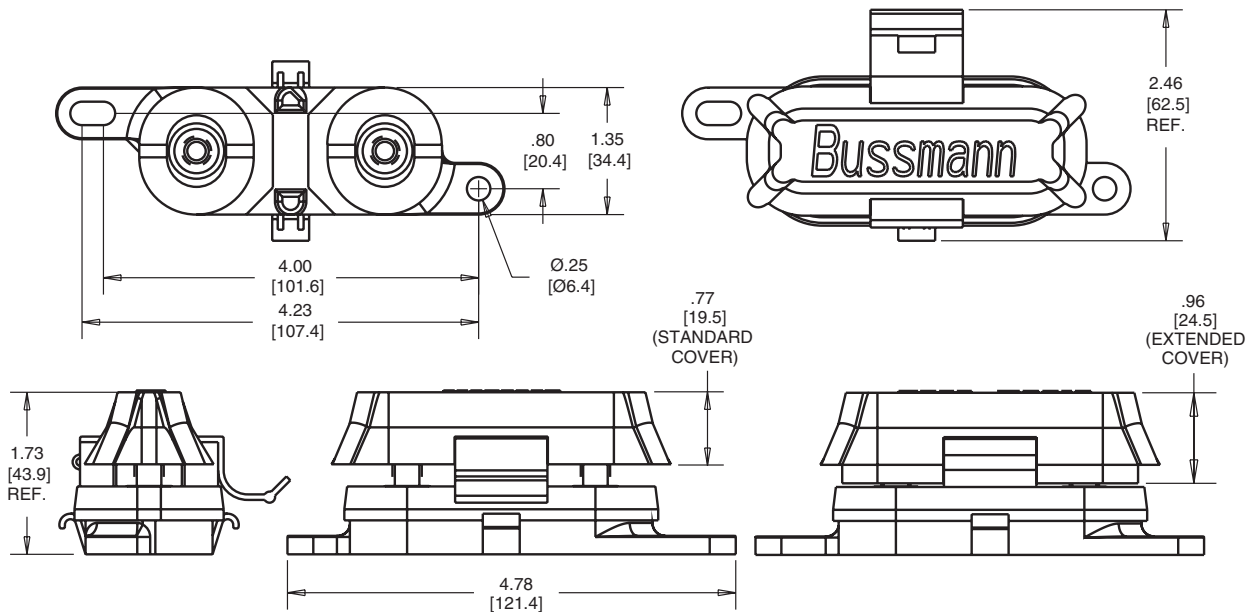

PART NUMBERING SYSTEM

Series	Base	Hardware	Cover
F M G	—	□	□
	1 - M8 studs 2 - 5/16-18 studs	0 - No hardware installed 1 - Nuts installed 2 - Nuts bulk	0 - No cover 1 - Cover (black) installed 2 - Cover (black) bulk 4 - Cover (red) installed 5 - Cover (red) bulk 6 - Extended Cover (black) installed 7 - Extended Cover (black) bulk 8 - Extended Cover (red) installed 9 - Extended Cover (red) bulk

INLINE FUSEHOLDERS

In-Line Fuseholders for Blade-Type Fuses

HHC, HHD, HHF, HHG, HHR, and HHS

In-Line Fuseholders for ATC® Blade-Type Fuses.
Rating: 32V, See table for max. amp. "Write-in" space for circuit identification on HHC holder.
 Plastic cover fits only HHD holder. HHR holder is waterproof with a locking cover and mounting hole. HHS is a self-stripping holder.

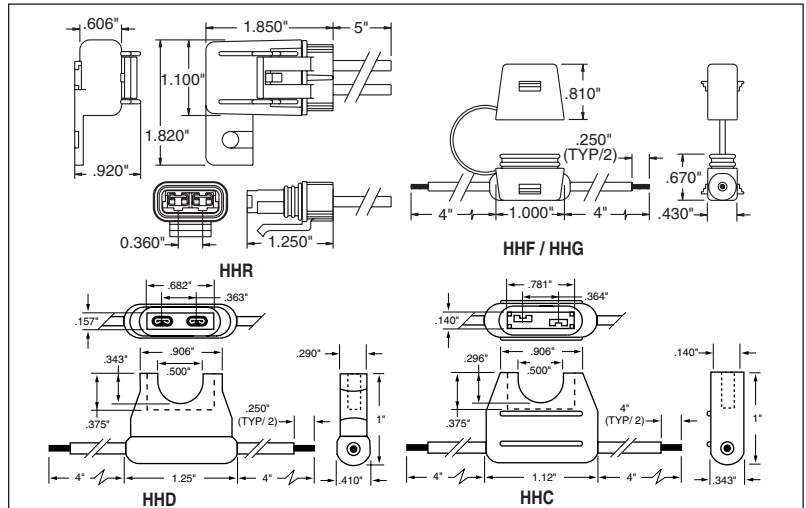

Dimensions in inches. Multiply by 25.4 for metric. (Dims. Shown are for reference only. Contact factory for latest prints)

ATC® Blade Type Holder

Catalog No.	Description	Fuse Size	Electrical Connection
HHC	Yellow fuseholder (body only)	1-20 A	#16 AWG lead black wire
HHD	Black fuseholder (body only)	1-30 A	#12 AWG lead yellow wire
HHD-C	Cover only	Fits only HHD	Clear polycarbonate
HHF	Black fuseholder w/cover	1-20 A	#16 AWG lead yellow wire
HHG	Black fuseholder w/cover	1-30 A	#12 AWG lead yellow wire
HHR	Black waterproof fuseholder w/locking cover & mounting hole	1-30 A	#12 AWG lead orange wire 5" length
HHS	Blue fuseholder	1-20 A	Self-stripping; accepts #18-#14 AWG copper wire only

HHL and HHM

In-Line Fuseholders for ATM MINI® Fuses.
Rating: 32V, See table for max. amp.
 Body material withstands high temps. Protective cover has removable straps. Rated IP67 with cover installed.

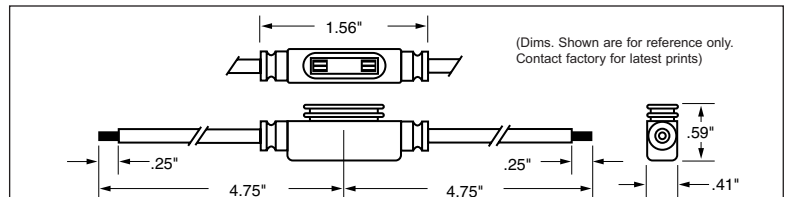

Dimensions in inches. Multiply by 25.4 for metric.

MINI® Fuse Blade Type Holder

Catalog No.	Description	Fuse Size	Electrical Connection
HHL	Fuseholder w/cover	2-20 A	#16 AWG lead black wire; 4" length
HHL-B	Body only		
HHM	Fuseholder w/cover	2-30 A	#12 AWG lead red wire; 4" length
HHM-B	Body only		
HHM-C	Cover only		

HHX

In-Line Fuseholder for MAXI™ Fuses.
Rating: 32V, 60A Max. Firewall mounting hole permits two or more holders to be mounted together. Cover comes with a removable strap.

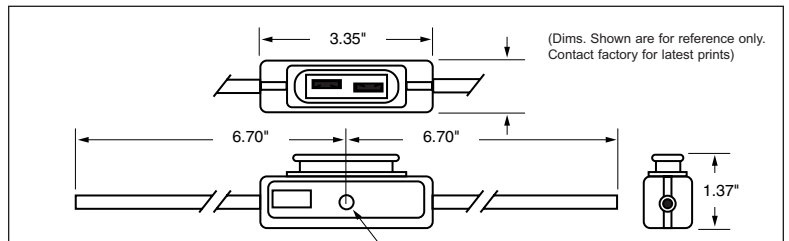

Dimensions in inches. Multiply by 25.4 for metric. .265" DIA. HOLE

MAXI™ Fuse Blade Type Holder

Catalog No.	Description	Fuse Size	Electrical Connection
HHX	Fuseholder w/cover	20-60 amps	#6 lead wire; 5" length
HHX-B	Body only		
HHX-C	Cover only		

SERIES 15250

Battery Disconnect Switch

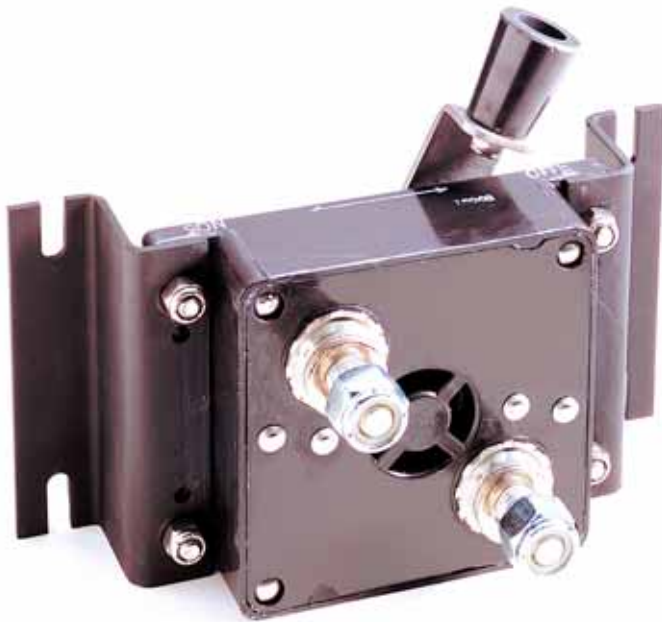

SPECIFICATIONS

Applications: A non-fused current interrupt disconnect designed for opening the circuit between a battery and the complete electrical load of a battery-powered system.
Rating: 400A continuous, . 50VAC/VDC. Vehicle cranking and max. surge currents to 2,000A (based on 20% duty cycle with ON times of 5 seconds max.).
Temperature Rating: -40°F (-40°C) to 150°F (65°C).
Termination: 1/2-13 Copper alloy stud.
Torque Rating: 420in-lb (47.5Nm) max.
Mounting Torque Rating: With mounting brackets: 48in-lb (5.4Nm) max; without mounting brackets: 10in-lb (1.1Nm) max.

OPTIONS

Handles: Three handle styles available.
Other: Lubricant-filled body with silicone sealant.

PART NUMBERING SYSTEM

Series	Handle Option	Bracket Option	Lubricant w/Sealant
15250	1		LR
	2	B - Bracket	(Grease Filled)
	3		

DIMENSIONS (15250-1B Shown) (Dims. shown are for reference only. Consult factory for latest prints)

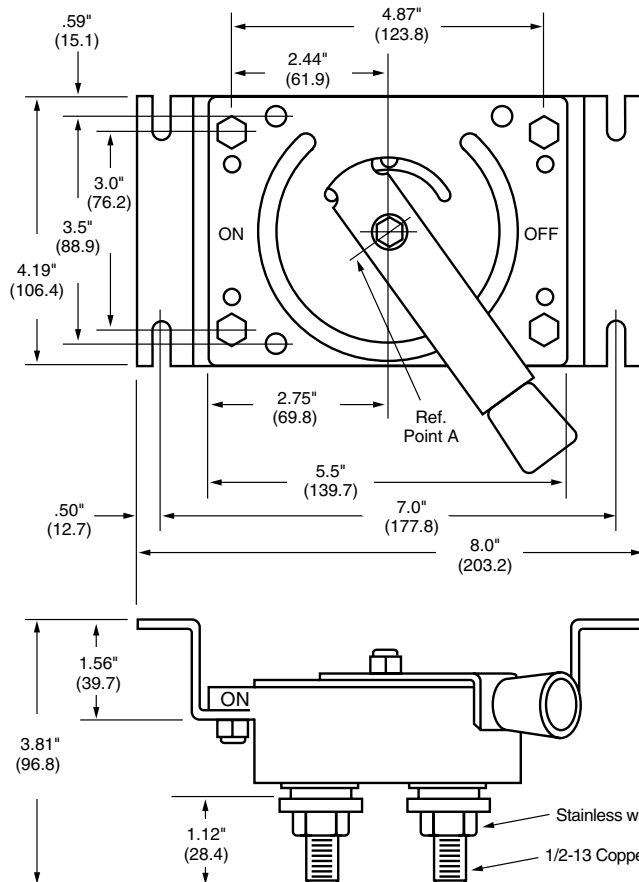

Handle Variations

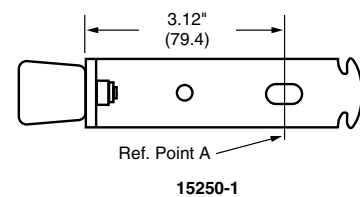

15250-1

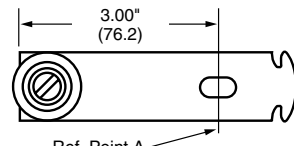

15250-2

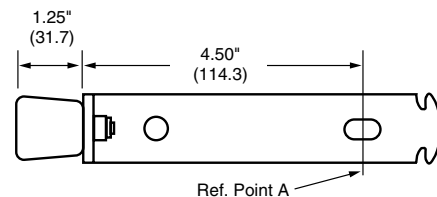

15250-3

STUD TYPE JUNCTION BLOCKS

SPECIFICATIONS

Applications: Heavy-duty ground or power connection points in AC or DC circuits. Feed-thru or stand alone mount options available for transformers, communication and computer power sections along with various vehicle electrical systems.

Mounting Torque Rating: 48in-lb (5.4Nm) max.

FEATURES

Modular design offers design and manufacturing flexibility.

Suggested Max. Termination Ratings:

Thread/Stud Size	Amperages
#10	50 amps
#1/4 & M6	100 amps
#5/16	200 amps
#3/8	250 amps
#1/2	400 amps



(Dims. shown are for reference only. Consult factory for latest prints)

DIMENSIONS

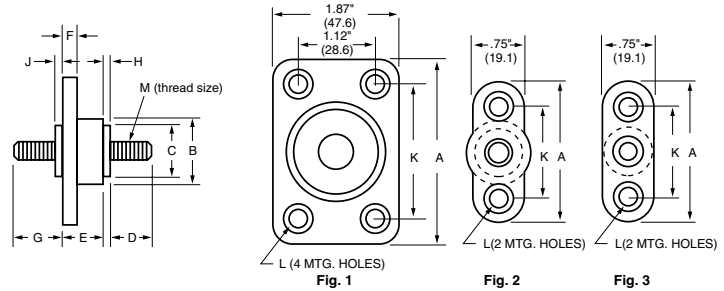

Part	Fig.	A	B	C	D	E	F	G	H	J	K	L	M	Max. Torque (in-lb)	Material	Color
C1925*	1	2.75 (69.8)	1.5 (38.1)	1.25 (31.7)	1.25 (31.7)	1.12 (28.6)	.37 (9.5)	1.12 (28.6)	.19 (4.8)	.19 (4.8)	2.0 (50.8)	.22 dia. w/.44 dia. C'bore x .16 deep	1/2-13	300	Thermoplastic / Zinc plated Brass	Red
C1925B*	1	2.75 (69.8)	1.5 (38.1)	1.25 (31.7)	1.25 (31.7)	1.12 (28.6)	.37 (9.5)	1.12 (28.6)	.19 (4.8)	.19 (4.8)	2.0 (50.8)	.22 dia. w/.44 dia. C'bore x .16 deep	1/2-13	300	Thermoplastic / Zinc plated Brass	Black
C1925-1*	1	2.75 (69.8)	1.5 (38.1)	1.25 (31.7)	1.25 (31.7)	1.12 (28.6)	.37 (9.5)	1.12 (28.6)	.19 (4.8)	.19 (4.8)	2.0 (50.8)	.22 dia. w/.44 dia. C'bore x .16 deep	1/2-13	300	Thermoplastic / Tin plated Brass	Red
C1925-1B*	1	2.75 (69.8)	1.5 (38.1)	1.25 (31.7)	1.25 (31.7)	1.12 (28.6)	.37 (9.5)	1.12 (28.6)	.19 (4.8)	.19 (4.8)	2.0 (50.8)	.22 dia. w/.44 dia. C'bore x .16 deep	1/2-13	300	Thermoplastic / Tin plated Brass	Black
C1925-2*	1	2.75 (69.8)	1.5 (38.1)	1.25 (31.7)	1.25 (31.7)	1.12 (28.6)	.37 (9.5)	1.12 (28.6)	.19 (4.8)	.19 (4.8)	2.0 (50.8)	.22 dia. w/.44 dia. C'bore x .16 deep	3/8-16	150	Thermoplastic / Tin plated Brass	Red
C1925-2B*	1	2.75 (69.8)	1.5 (38.1)	1.25 (31.7)	1.25 (31.7)	1.12 (28.6)	.37 (9.5)	1.12 (28.6)	.19 (4.8)	.19 (4.8)	2.0 (50.8)	.22 dia. w/.44 dia. C'bore x .16 deep	3/8-16	150	Thermoplastic / Tin plated Brass	Black
C1933	1	2.75 (69.8)	1.44 (36.6)	1.25 (31.7)	1.5 (38.1)	1.12 (28.6)	.37 (9.5)	None	.19 (4.8)	None	2.0 (50.8)	.22 dia.	1/2-13	300	Thermoplastic / Zinc plated Brass	Black
C1933-1	1	2.75 (69.8)	1.44 (36.6)	1.25 (31.7)	1.5 (38.1)	1.12 (28.6)	.37 (9.5)	None	.19 (4.8)	None	2.0 (50.8)	.22 dia.	5/16-18	75	Thermoplastic / Zinc plated Brass	Black
C1938*	2	2.06 (52.4)	.94 (23.8)	.69 (17.5)	.87 (22.2)	.69 (17.5)	.31 (7.9)	.94 (23.8)	.06 (1.6)	.06 (1.6)	1.31 (33.3)	.22 dia. w/.41 dia. C'bore x .14 deep	3/8-16	150	Thermoplastic / Zinc plated Brass	Black
C1938R*	2	2.06 (52.4)	.94 (23.8)	.69 (17.5)	.87 (22.2)	.69 (17.5)	.31 (7.9)	.94 (23.8)	.06 (1.6)	.06 (1.6)	1.31 (33.3)	.22 dia. w/.41 dia. C'bore x .14 deep	3/8-16	150	Thermoplastic / Zinc plated Brass	Red
C1938-1*	2	2.06 (52.4)	.94 (23.8)	.69 (17.5)	.87 (22.2)	.69 (17.5)	.31 (7.9)	.94 (23.8)	.06 (1.6)	.06 (1.6)	1.31 (33.3)	.22 dia. w/.41 dia. C'bore x .14 deep	5/16-18	75	Thermoplastic / Tin plated Brass	Black
C1938-1R*	2	2.06 (52.4)	.94 (23.8)	.69 (17.5)	.87 (22.2)	.69 (17.5)	.31 (7.9)	.94 (23.8)	.06 (1.6)	.06 (1.6)	1.31 (33.3)	.22 dia. w/.41 dia. C'bore x .14 deep	5/16-18	75	Thermoplastic / Tin plated Brass	Red
C2791*	3	2.06 (52.4)	.69 (17.5)	.44 (11.2)	.62 (15.9)	.69 (17.5)	.31 (7.9)	.69 (17.5)	.06 (1.6)	.06 (1.6)	1.31 (33.3)	.22 dia. w/.41 dia. C'bore x .14 deep	1/4-20	30	Thermoplastic / Zinc plated Brass	Black
C2791-R*	3	2.06 (52.4)	.69 (17.5)	.44 (11.2)	.62 (15.9)	.69 (17.5)	.31 (7.9)	.69 (17.5)	.06 (1.6)	.06 (1.6)	1.31 (33.3)	.22 dia. w/.41 dia. C'bore x .14 deep	1/4-20	30	Thermoplastic / Zinc plated Brass	Red
C2909*	3	2.06 (52.4)	.69 (17.5)	.44 (11.2)	.62 (15.9)	1.0 (25.4)	.31 (7.9)	.69 (17.5)	.06 (1.6)	.06 (1.6)	1.31 (33.3)	.22 dia. w/.41 dia. C'bore x .14 deep	10-32	24	Thermoplastic / Zinc plated Brass	Black
C2909-1*	3	2.06 (52.4)	.69 (17.5)	.44 (11.2)	.62 (15.9)	1.0 (25.4)	.31 (7.9)	.69 (17.5)	.06 (1.6)	.06 (1.6)	1.31 (33.3)	.22 dia. w/.41 dia. C'bore x .14 deep	1/4-20	30	Thermoplastic / Zinc plated Brass	Black
C4044*	2	2.06 (52.4)	.87 (22.2)	.62 (15.9)	.62 (15.9)	1.12 (28.6)	.31 (7.9)	.94 (23.8)	.06 (1.6)	.06 (1.6)	1.31 (33.3)	.22 dia. w/.41 dia. C'bore x .14 deep	3/8-16	150	Thermoplastic / Zinc plated Brass	Black
C4044-1*	2	2.06 (52.4)	.87 (22.2)	.62 (15.9)	.62 (15.9)	1.12 (28.6)	.31 (7.9)	.94 (23.8)	.06 (1.6)	.06 (1.6)	1.31 (33.3)	.22 dia. w/.41 dia. C'bore x .14 deep	3/8-16	150	Thermoplastic / Tin plated Brass	Black
C4044-1R*	2	2.06 (52.4)	.87 (22.2)	.62 (15.9)	.62 (15.9)	1.12 (28.6)	.31 (7.9)	.94 (23.8)	.06 (1.6)	.06 (1.6)	1.31 (33.3)	.22 dia. w/.41 dia. C'bore x .14 deep	3/8-16	150	Thermoplastic / Tin plated Brass	Red
C5898*	2	2.06 (52.4)	.94 (23.8)	.69 (17.5)	.87 (22.2)	.69 (17.5)	.31 (7.9)	.94 (23.8)	.06 (1.6)	.06 (1.6)	1.31 (33.3)	.22 dia. w/.41 dia. C'bore x .14 deep	3/8-16	150	Thermoplastic / Zinc plated Brass	Red
C6344-2	2	2.06 (52.4)	.87 (22.2)	.62 (15.9)	.62 (15.9)	1.12 (28.6)	.31 (7.9)	None	.06 (1.6)	None	1.31 (33.3)	.22 dia. w/.41 dia. C'bore x .14 deep	1/2-20	150	Thermoplastic / Zinc plated Steel	Black
C7018*	3	2.06 (52.4)	.69 (17.5)	.44 (11.2)	.47 (11.9)	.69 (17.5)	.31 (7.9)	.53 (13.5)	.06 (1.6)	.06 (1.6)	1.31 (33.3)	.22 dia. w/.41 dia. C'bore x .14 deep	M6	55	Thermoplastic / Zinc plated Steel	Black
C7020*	2	2.06 (52.4)	.94 (23.8)	.69 (17.5)	.88 (22.2)	.69 (17.5)	.31 (8.0)	1.25 (31.8)	.06 (1.6)	.06 (1.6)	1.31 (33.3)	.22 dia. w/.41 dia. C'bore x .14 deep	3/8-16	150	Thermoplastic / Zinc plated Brass	Red
JB3816-2	2	2.12 (54.0)	.98 (24.9)	.62 (15.9)	.87 (22.2)	.69 (17.5)	.31 (7.9)	None	.06 (1.6)	None	1.37 (34.9)	.22 dia. w/.37 dia. C'bore x .14 deep	3/8-16	150	Thermoplastic / Zinc plated Steel	Black
JB3816-3	2	2.12 (54.0)	.98 (24.9)	.62 (15.9)	.87 (22.2)	.69 (17.5)	.31 (7.9)	None	.06 (1.6)	None	1.37 (34.9)	.22 dia. w/.37 dia. C'bore x .14 deep	3/8-16	150	Thermoplastic / Zinc plated Steel	Red

*Feed-thru Options – Nuts & washers; consult factory.

STUD TYPE JUNCTION BLOCKS (Non Feed-Thru)

Series C4559 & C6083

SPECIFICATIONS

Rating: 30A, 600V

Temperature Rating: 250°F (120°C)

Materials: Black thermoplastic with zinc-plated steel studs.

Termination: #10-24 threaded studs on .750" centers. Studs feature a "dog point" to guide nut onto thread.

Torque Rating: 25 in-lb (2.8Nm) max.

Mounting Torque Rating: 24in-lb (2.7Nm) max.

OPTIONS

Positions: 2-16 positions available.

FEATURES

Numbers and arrows molded on top of barriers indicate terminals.

Compliances: UL/CSA; CE Certified.



Dimensions (Dims. shown are for reference only. Consult factory for latest prints)

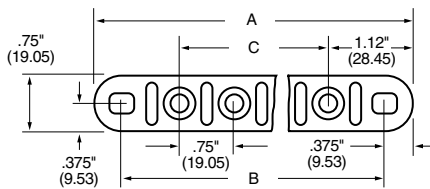

Other series available with .750" centers:

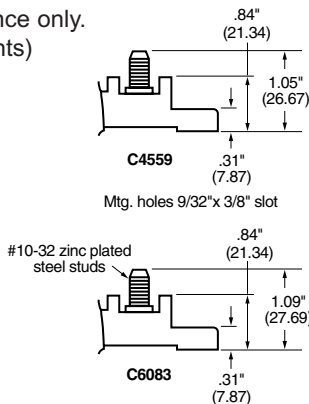

(A,B,C Dimensions are the same as C4559)

Part No.	A	B	C
C4559-2	3.00 (76.2)	2.25 (57.1)	0.75 (19.0)
C4559-3	3.75 (95.2)	3.00 (76.2)	1.50 (38.1)
C4559-4	4.50 (114.3)	3.75 (95.2)	2.25 (57.1)
C4559-5	5.25 (133.3)	4.50 (114.3)	3.00 (76.2)
C4559-6	6.00 (152.4)	5.25 (133.3)	3.75 (95.2)
C4559-7	6.75 (171.4)	6.00 (152.4)	4.50 (114.3)
C4559-8	7.50 (190.5)	6.75 (171.4)	5.25 (133.3)
C4559-9	8.25 (209.5)	7.50 (190.5)	6.00 (152.4)
C4559-10	9.00 (228.6)	8.25 (209.5)	6.75 (171.4)
C4559-11	9.75 (247.6)	9.00 (228.6)	7.50 (190.5)
C4559-12	10.50 (266.7)	9.75 (247.6)	8.25 (209.5)
C4559-13	11.25 (285.7)	10.50 (266.7)	9.00 (228.6)
C4559-14	12.00 (308.4)	11.25 (285.7)	9.75 (247.6)
C4559-15	12.75 (323.8)	12.00 (308.4)	10.50 (266.7)
C4559-16	13.50 (342.9)	12.75 (323.8)	11.25 (285.7)

Series C5237 & JB1032

SPECIFICATIONS

Rating: UL: 30A, 300V; CSA: 30A, 600V.

Temperature Rating: 250°F (120°C)

Materials: Black thermoplastic with brass studs.

Termination: #10-32 threaded studs on .625" centers. Studs feature a "dog point" to guide nut onto thread.

Torque Rating: 25 in-lb (2.8Nm) max.

Mounting Torque Rating: 24in-lb (2.7Nm) max.

OPTIONS

Positions: 1-15 positions available.

FEATURES

Numbers and arrows molded on top of barriers indicate terminals.

Compliances: UL/CSA; CE Certified.



Dimensions (Dims. shown are for reference only. Consult factory for latest prints)

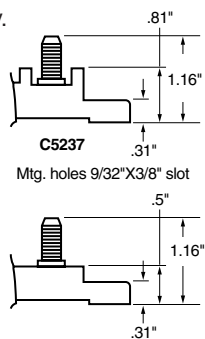
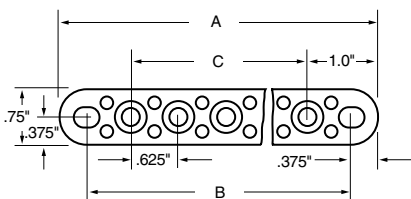

JB1032-120-XX
(No bosses between studs)
(A,B,C Dimensions are the same as C5237)

Part No.	A	B	C
C5237-1	2.00 (50.8)	1.25 (31.7)	-
C5237-2	2.62 (66.7)	1.87 (47.5)	.625 (15.9)
C5237-3	3.25 (82.5)	2.50 (63.4)	1.25 (31.7)
C5237-4	3.87 (98.4)	3.12 (79.4)	1.87 (47.5)
C5237-5	4.50 (114.3)	3.75 (95.2)	2.50 (63.4)
C5237-6	5.12 (130.8)	4.37 (111.1)	3.12 (79.4)
C5237-7	5.75 (146.0)	5.00 (127.0)	3.75 (95.2)
C5237-8	6.37 (161.9)	5.62 (142.9)	4.37 (111.1)
C5237-9	7.00 (177.8)	6.25 (158.7)	5.00 (127.0)
C5237-10	7.62 (193.7)	6.87 (174.6)	5.62 (142.9)
C5237-11	8.25 (209.5)	7.50 (190.5)	6.25 (158.7)
C5237-12	8.87 (225.4)	8.12 (206.4)	6.87 (174.6)
C5237-13	9.50 (241.3)	8.75 (222.2)	7.50 (190.5)
C5237-14	10.12 (257.2)	9.37 (238.1)	8.12 (206.4)
C5237-15	10.75 (273.0)	10.00 (254.0)	8.75 (222.2)

Basic Overcurrent Technology

Overcurrent devices may serve several purposes in electrical circuits:

- To protect components, equipment, and associated wiring from the effects of electric circuit overloads and/or short circuits.
- To isolate branch circuits from the main power supply once an overload or short circuit has occurred.

Fuses and circuit breakers are commonly selected as the preferred overcurrent device.

TYPES OF OVERCURRENT

An overcurrent device is constructed to react in a prescribed fashion to varying levels of electrical current, where at pre-determined levels, the device provides interruption of the current flow through it. Any current that exceeds the ampere rating of the fuse or circuit breaker is an overcurrent. Overcurrents are generally classified as either short circuits or overloads and are defined as follows:

- **Short circuit** - a current that greatly exceeds the rating of the device. It is caused when a malfunction or accident creates a break in the normal path allowing electricity to flow directly to ground or another phase. This shorter current path bypasses the resistance offered by the circuit components and the load connected in the normal current path. In this situation there is little resistance to impede the current and the current will build to a level where the heat generated can cause insulation damage and/or equipment breakdown.
- **Overload** - an overcurrent that is within the normal current path. Overloads occur when the current exceeds the value for which the equipment or associated wiring is rated. This typically occurs when too many devices are connected to the circuit or when a device connected to the circuit malfunctions. Overloads are also caused by harmless temporary surge currents; such as when motors are started. These overload currents are normal, usually brief in duration, and have no harmful effect on the circuit components. (It is important that protective devices do not react to such overloads.) Sustained overloads, however, may slowly cause overheating of the wiring and the components. Provided the overload is of sufficient magnitude and duration to activate the device, the circuit protection device shall open before the overload induces system component failures.

SELECTING OVERCURRENT PROTECTION

During normal conditions, an overcurrent protection device must carry the current without nuisance openings. However, when an overload or short circuit occurs the device interrupts the overcurrent and withstands the voltage across the device. To properly select an overcurrent device the following items must be carefully

considered:

- **Voltage rating** - represents the maximum system voltage present in the circuit in which the overcurrent device is installed. The system voltage should not exceed this value for proper operation of the device during an overcurrent event.
- **Current Rating** - the amperage value marked on the circuit protection device. The circuit protection device is designed to handle this value under steady operating conditions and at room ambient temperatures. Since field applications often deliver loading conditions and ambient temperatures that vary from ideal nominal settings, it is recommended that circuit designers select device ratings above the nominal circuit current continuous load to prevent nuisance trips. Additionally, the continuous current flowing through the overcurrent protective device should not be more than 80% of the current rating.
- **Characteristics of equipment to be protected** - during the operation of protected equipment, system current can significantly vary. This is particularly evident when motor or other inductive loads in the circuit cause large current surges during start-up. Circuit protection designers should be aware of these surges and/or in-rush characteristics and select the overcurrent protection devices accordingly.
- **Available short circuit current** - during a fault or short circuit condition the fuse or circuit breaker may see a large amount of current. Large DC battery supplies and high current rated electric distribution buses often have this potential for severe short circuits. In these situations, the circuit protection device should have an interrupting rating that is equal to or greater than the short circuit current that can be delivered.
- **Ambient temperature** - the time it takes to interrupt the current is dependent upon the ambient current temperature characteristics. Ambient temperature refers to the temperature of the air immediately surrounding the circuit protection device. The ambient temperature around the fuse or circuit breaker can be appreciably different than the outside room or larger enclosure containing the device. This can occur when the device is contained in a tight area or it is mounted in or near a heat-producing component such as a transformer or resistor. When selecting a fuse or circuit breaker at ambient temperatures significantly different from the stated nominal temperature, the circuit designer should adjust the selected overcurrent protection rating based on the published temperature re-rating curves.

OVERCURRENT PROTECTION DEVICES

Two categories of overcurrent devices are available.

Fuses

The key component of a fuse is the "element", a short piece of metallic wire or link made of a material with a

relatively low and predictable melting point. Fuses are current-sensitive devices and the resistance is so low that they simply act as a conductor. Circuit protection is provided when the fuse element melts and interrupts an overcurrent. The key criteria used to judge the performance of a fuse is the time-versus-current characteristic curve. This curve can be used to match the fuse with the load. Fuses may be preferred when fast response to a short circuit condition is required or when high available short circuit currents occur. Fuse characteristic curves can be used to carefully size the device to a critical or special application.

Thermal Circuit Breakers

The basic components of a thermal circuit breaker are the thermal alloy element, electrical contacts, and the terminals for external connections. When an overload occurs, heat is generated as the current flows through the thermal alloy element causing it to deflect and separate the electrical contacts, interrupting current flow. An important parameter used to judge the performance of a thermal circuit breaker is the time-versus-current characteristic curve, which is similar to that of a fuse. A thermal circuit breaker is generally not a one-event type device as is a fuse. The resettable features of circuit breakers are often found attractive for use in electrical circuits where non-resetting interruption of current flow is undesirable. ***It is important to note that cycle life of a thermal circuit breaker is impacted both by the operational characteristic of the circuit breaker as well as the relative magnitude and duration of overcurrents or short circuits that the device experiences.*** There are different operational characteristics of **Cooper Bussmann** thermal circuit breakers, which are described below.

CIRCUIT BREAKER OPERATIONAL CHARACTERISTICS

Four different methods for reset are generally available:

- **Type I (automatic reset):** the circuit breaker trips and resets in response to the overcurrent condition in a repetitive fashion. ***This version should be used in applications that provide for other self-limiting or non-resettable means (such as after a main fuse, main manual-reset circuit breaker, or momentary switch). These devices, while automatic in reset function, are not designed for long-term cycling conditions in applications where operator awareness of circuit fault or serviceability access is limited, leading to unsatisfactory failure events.*** Refer to SAE J553 or J1625 for additional details.
- **Type II (modified reset):** the circuit breaker contains an additional resistive component that enables the device to have only brief trip and reset activity and then afterwards maintains an open circuit condition (except for a low

milliamp draw through the resistor). Requires minimum voltage/current to maintain open circuit - see standards for details SAEJ553.

- **Type III (manual reset):** the circuit breaker will trip in response to an overcurrent condition after which a reset button or lever extends externally to indicate that the breaker has tripped and is in a non-conducting state. The trip indicator button or lever must be manually activated to return the device to normal operation.
- **Type III (switchable):** same as the manual Type III manual reset with the additional feature of allowing the user to open the circuit using an externally accessible trip mechanism.

CIRCUIT BREAKER APPLICATION NOTES

- **Circuit Breaker Performance - Cooper Bussmann** thermal circuit breakers are designed to conform to relevant industry standards (refer to individual models for standard references). ***There are specific performance aspects that may not always make circuit breakers suitable for certain applications, especially in circuits that are incapable of providing enough current to operate the circuit breaker in a timely manner relative to the associated components and wiring.*** It is of utmost importance that the circuit designer investigates components that have finite overload capabilities which are below the time-current levels to initiate timely circuit breaker activation.
- **Evaluation -** Design-in situations require that the user considers all application conditions and conducts operational testing to establish the correctness of ampere/voltage rating as well as overload protection suitability. Further review of industry standards is advised to understand all performance aspects that affect usage.
- **Wiring Considerations -** Additional evaluation of circuit conditions is essential to achieve proper matching of wire sizes to the current load conditions anticipated under normal operating conditions, and estimated abnormal operating conditions when overloads could occur. Thermal circuit breakers and fuses introduce some level of resistance to the current path where installed. These factors should also be considered when choosing wire, both in gauge as well as in temperature rating of insulation.
- **Installation Environment -** Thermal circuit breakers are produced in various configurations. Installation environmental conditions need to be considered and compared to the capability of the particular product of choice. Not all circuit breaker designs are suitable for harsh conditions, such as may be encountered under hood or external cavities.

MINI BLADE FUSES



DIMENSIONS (Dims. shown are for reference only. Consult factory for latest prints)

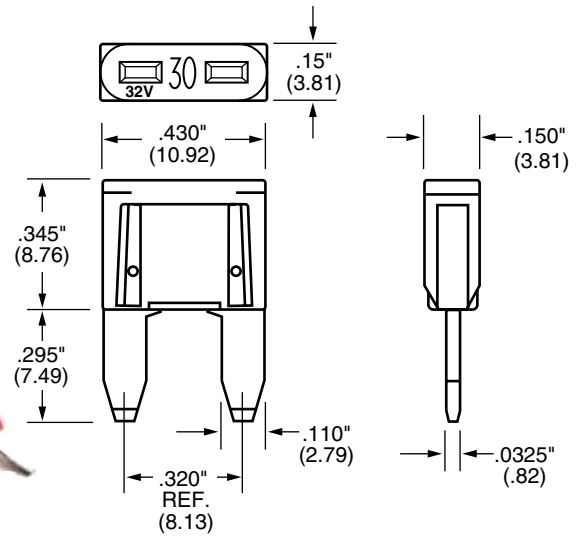

MINI FUSE PULLER - PART NUMBER 32002



See page 27 for more information.

ATM Mini – Fuse
Fast Acting

SPECIFICATIONS

- Current Rating:** 2-30A.
- Voltage Rating:** 32VDC.
- Interrupt Rating:** 1,000A @ 32VDC.
- Housing Material:** UL-Rated 94V-0 thermoplastic.
- Terminal Material:** Silver-plated zinc alloy.
- Marking:** Amperage marking is OCR compliant.
- Compliances:** UL-Listed; SAE J2077; ISO 8820-3.

Consult factory for higher voltage fuses.

Part No.	Amp Rating	Color
BK/ATM-2	2	Gray
BK/ATM-3	3	Violet
BK/ATM-4	4	Pink
BK/ATM-5	5	Tan
BK/ATM-7.5	7.5	Brown
BK/ATM-10	10	Red
BK/ATM-15	15	Lt. Blue
BK/ATM-20	20	Yellow
BK/ATM-25	25	Natural
BK/ATM-30	30	Green

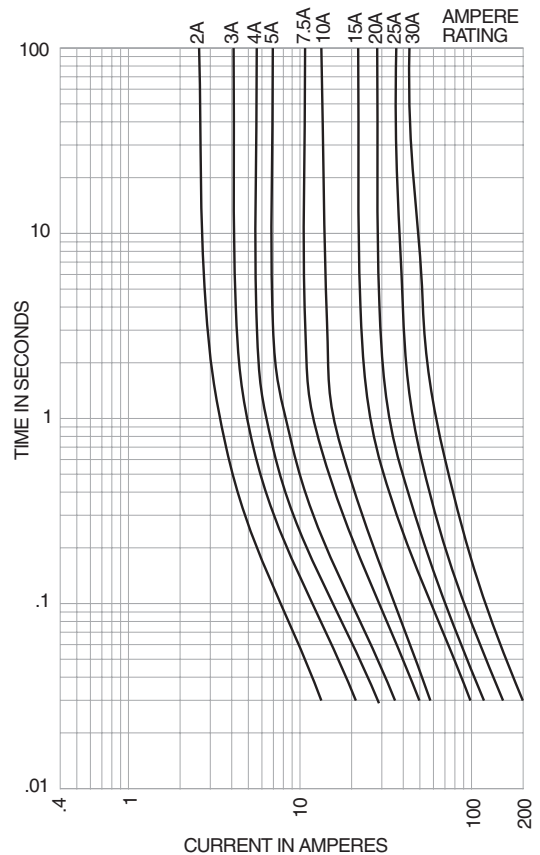

SERIES 21X MINI CIRCUIT BREAKERS

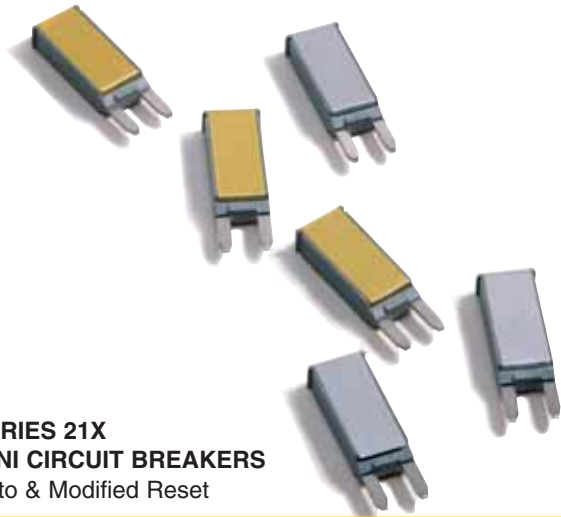

**SERIES 21X
MINI CIRCUIT BREAKERS**
Auto & Modified Reset

SPECIFICATIONS

Single Pole Thermal Type Breakers

Rating: 5-30A; 14VDC.

Interrupt Rating: 150A @ 14VDC (5-10A versions); 225A @ 14VDC (15A version); 300A @ 14VDC (20A version); 450A @ 14VDC (25-30A versions).

Operating Temperature Rating: -40°F (-40°C) to 185°F (85°C).

Storage Temperature Rating: -40°F (-40°C) to 260°F (125°C).

Materials: Grey UL-Rated 94V-0 thermoplastic housing with metal cover: gold (Type I) or silver (Type II).

Marking: Standard marking includes amp/voltage ratings, part number, and date code. OCR marking is available.

Termination: Compatible with 280 Type fuse blocks using 0.32in. (8.1mm) centerline spacing.

Compliances: SAE J553 Type I and Type II Circuit Breakers.

DIMENSIONS (Dims. shown are for reference only. Consult factory for latest prints)

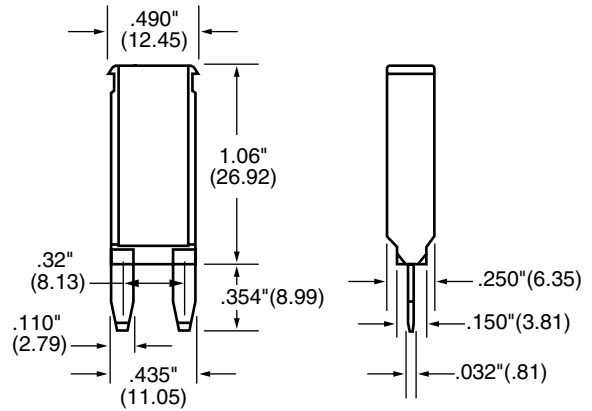

MINI FUSE PULLER - PART NUMBER 32002



See page 27 for more information.

TRIP TIME VS. PERCENT OF RATED CURRENT

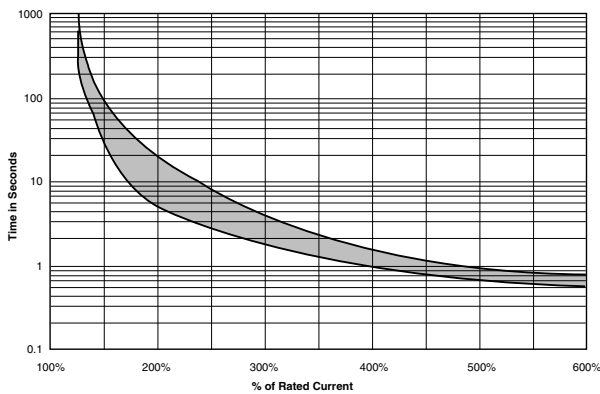

TEMPERATURE DERATING CURVES

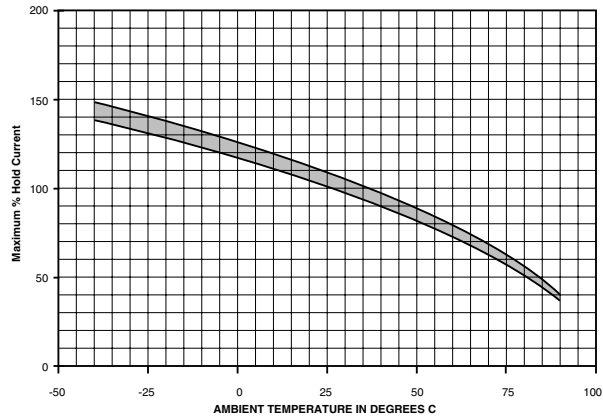

PART NUMBERING SYSTEM

Series



211 - Type I, 14VDC
212 - Type II, 14VDC

Rating



05 - 5 amps
75 - 7.5 amps
10 - 10 amps
15 - 15 amps
20 - 20 amps
25 - 25 amps
30 - 30 amps

Marking



00 - Std. Marking
(Consult Factory for Special Marking Options)

Special Options



(Consult Factory for Special Options)

ATC® BLADE FUSES



ATC® Blade – Type Fuse
Fast Acting

SPECIFICATIONS

- Current Rating:** 1-40A.
 - Voltage Rating:** 32VDC.
 - Interrupt Rating:** 1,000A @ 32VDC.
 - Housing Material:** UL-Rated 94V-0 thermoplastic.
 - Terminal Material:** Tin-plated zinc alloy.
 - Marking:** Amperage marking is OCR compliant.
 - Compliances:** UL-Recognized (3-40A); SAE J1284; ISO 8820-3
- Consult factory for higher voltage fuses.

Part No.	Amp Rating	Color
BK/ATC-1	1	Black
BK/ATC-2	2	Gray
BK/ATC-3	3	Violet
BK/ATC-4	4	Pink
BK/ATC-5	5	Tan
BK/ATC-7.5	7.5	Brown
BK/ATC-10	10	Red
BK/ATC-15	15	Lt. Blue
BK/ATC-20	20	Yellow
BK/ATC-25	25	Clear
BK/ATC-30	30	Green
BK/ATC-40	40	Amber

DIMENSIONS (Dims. shown are for reference only. Consult factory for latest prints)

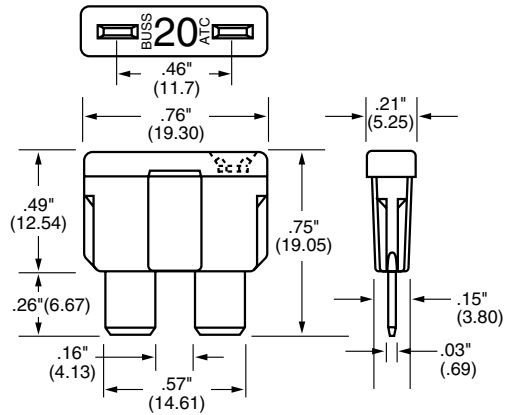

ATC® FUSE PULLER - PART NUMBER 32003

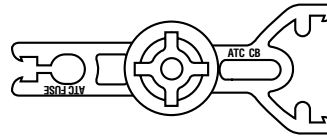

See page 27 for more information.

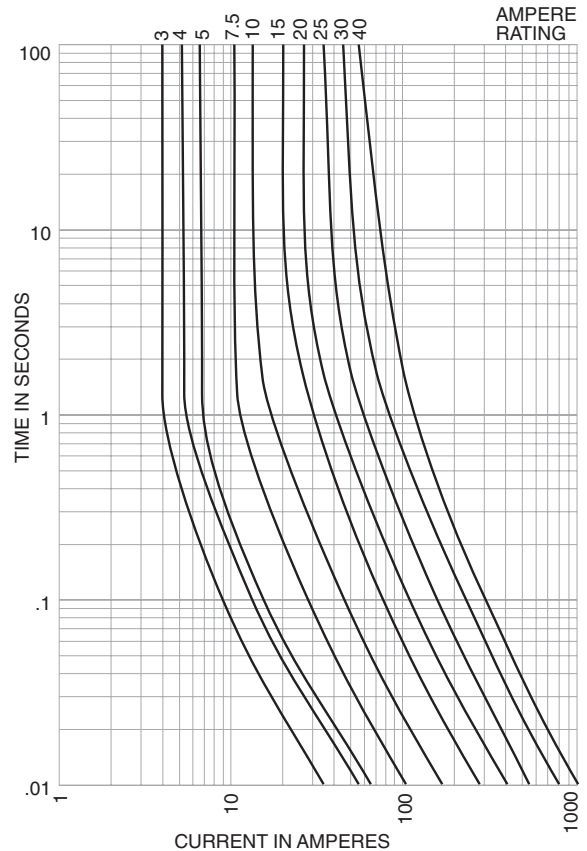

SERIES 22X ATC® CIRCUIT BREAKERS

ATC® CIRCUIT BREAKERS
Auto, Modified, & Manual Reset

SPECIFICATIONS

Single Pole Thermal Type Breakers

Rating: 5-30A, 14VDC; 28VDC (Series 223 & 226).

Interrupt Rating: 150A @ 14VDC (5-10A versions); 225A @ 14VDC (15A version); 300A @ 14VDC (20A version); 450A @ 14VDC (25-30A versions).

Operating Temperature Rating: -40°F (-40°C) to 185°F (85°C).

Storage Temperature Rating: -40°F (-40°C) to 260°F (125°C).

Materials: UL-Rated 94V-0 thermoplastic housing with gold metal cover (Type I) or silver metal cover (Type II & III).

Marking: Standard marking includes amp/volt ratings, part number, and date code. Type III reset buttons are color-coded to amperage ratings. Push-to-trip option is available on manual reset version. OCR marking is available.

Termination: Compatible with 280 Type or ATC® fuse blocks.

Compliances: SAE J553.



Dimensions (Dims. shown are for reference only. Consult factory for latest prints.)

Terminal Options

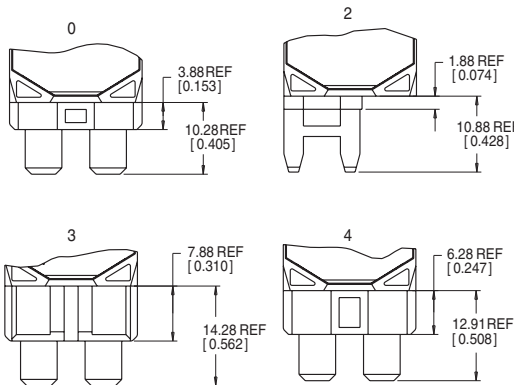
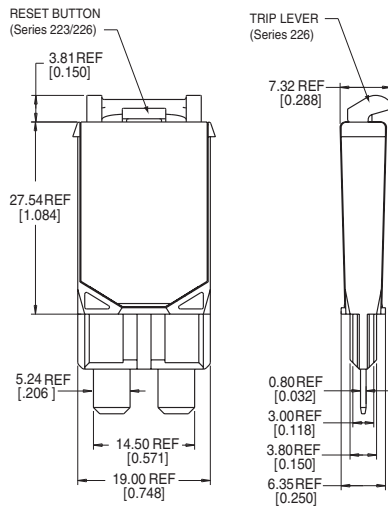

ATC® Circuit Breaker Puller Part Number 32003

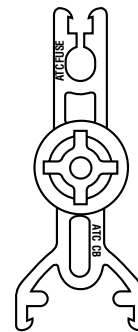

See page 27 for more information.

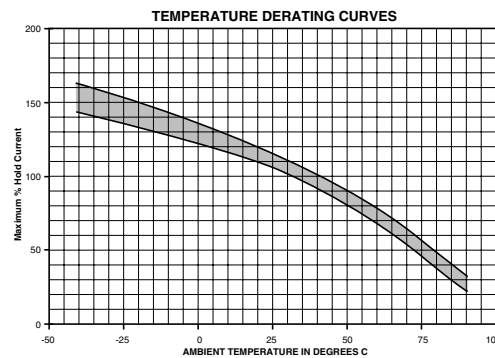
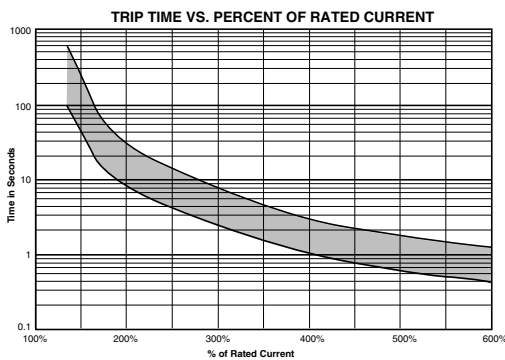

PART NUMBERING SYSTEM

Series



221 - Type I, 14VDC
 222 - Type II, 14VDC
 223 - Type III, 28VDC
 226 - Type III w/Push-to-trip option, 28VDC

Consult factory for terminal option availability.

Rating



05 - amps [LT. Brown (Tan)]*
 75 - 7.5 amps [Brown]*
 10 - 10 amps [Red]*
 15 - 15 amps [Blue]*
 20 - 20 amps [Yellow]*
 25 - 25 amps [White]*
 30 - 30 amps [Green]*

*Reset Button Color (223 & 226 only).

Terminal



0 - ATC® Fuse, 4mm Insertion Depth
 2 - 8.1mm Centerline 280 (MINI)
 3 - ATC® Fuse, Delphi Packard Autofuse Block (e.g. 12004943)
 4 - ATC® Fuse, Blocks with Raised Shrouds, 6.4mm Insertion Depth

Marking



00 - Std. Marking
 (Consult factory for special marking options)

SERIES 227 ATC® CIRCUIT BREAKERS (Low-Profile)

ATC® CIRCUIT BREAKERS
Manual Reset



SPECIFICATIONS

Single Pole Thermal Type Breakers

Rating: 5-30A, 28VDC.

Interrupt Rating: 2000A @ 28VDC.

Operating Temperature Rating: -40°F (-40°C) to 185°F (85°C).

Storage Temperature Rating: -40°F (-40°C) to 260°F (125°C).

Materials: UL-Rated 94V-0 thermoplastic body. Tin-plated copper alloy terminals.

Marking: Cover is color-coded to amperage ratings.

Termination: 5.2mm wide blades compatible with ATC® type fuse blocks.

Compliances: SAEJ553; SAEJ1171 (ignition protected).

Consult factory for time characteristic curves.



DIMENSIONS (Dims. shown are for reference only. Consult factory for latest prints)

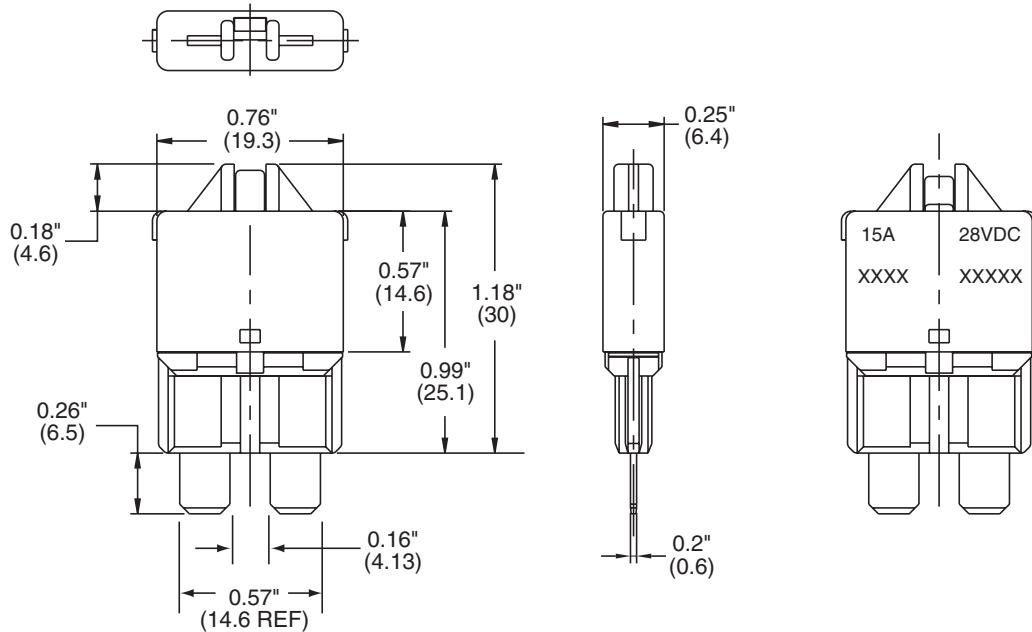

PART NUMBERING SYSTEM

Series	Rating	Marking
227	□□	— 00
	05 – 5 amps [LT. Brown (Tan)]	00-Std. Marking
	06 – 6 amps [Moss Green]	(Consult factory for special marking.)
	75 – 7.5 amps [Brown]	
	10 – 10 amps [Red]	
	15 – 15 amps [Blue]	
	20 – 20 amps [Yellow]	
	25 – 25 amps [White]	
	30 – 30 amps [Green]	

MAXI[®] BLADE FUSES



DIMENSIONS (Dims. shown are for reference only. Consult factory for latest prints)

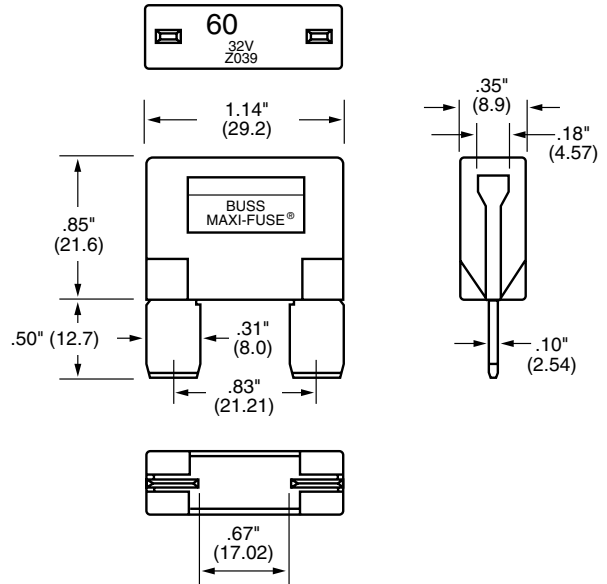

MAXI[®] – Fuse
Fast-Acting

SPECIFICATIONS

- Current Rating:** 20-80A.
- Voltage Rating:** 32VDC.
- Interrupt Rating:** 1,000A @ 32VDC.
- Housing Material:** UL-Rated 94V-0 thermoplastic.
- Terminal Material:** Silver-plated zinc alloy.
- Marking:** Amperage marking is OCR compliant.
- Compliances:** SAE J1888, ISO 8820-3.

Part No.	Amp Rating	Color
BK/MAX-20	20	Yellow
BK/MAX-30	30	Green
BK/MAX-40	40	Orange
BK/MAX-50	50	Red
BK/MAX-60	60	Blue
BK/MAX-70	70	Tan
BK/MAX-80	80	Neutral

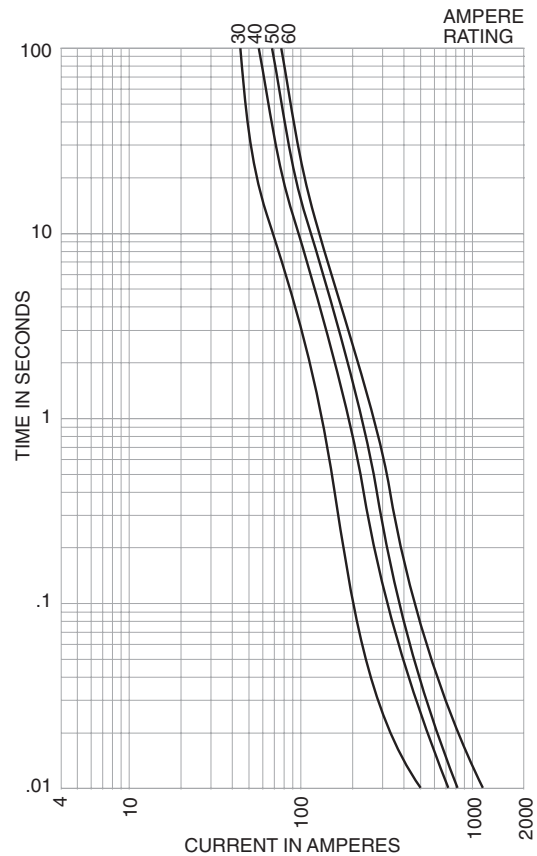

SERIES 19X MAXI® CIRCUIT BREAKERS



Series 19X MAXI® Circuit Breakers
Auto, Manual & Modified Reset

SPECIFICATIONS

Single Pole Thermal Type Breakers

- Rating:** 8-50A; 14VDC; 28VDC (Series 193, 194, & 195).
- Interrupt Rating:** 150A @ 14VDC (8-10A versions); 225A @ 14VDC (15A version); 300A @ 14VDC (20A version); 450A @ 14VDC (25-30A versions); 600A @ 4VDC (35-40A versions); 750A @ 14VDC (50A version).
- Operating Temperature Rating:** -40°F (-40°C) to 185°F (85°C).
- Storage Temperature Rating:** -40°F (-40°C) to 260°F (125°C).
- Materials:** Grey UL-Rated 94V-0 thermoplastic.
- Termination:** Compatible with fuse blocks accepting MAXI® or ATC® blade fuses.
- Compliances:** SAE J553.

10 AMPS & BELOW TYPICAL CURVE
 15 AMPS & ABOVE TYPICAL CURVE

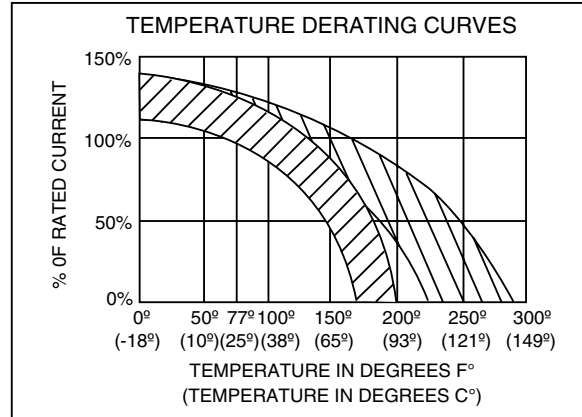

10 AMPS & BELOW TYPICAL CURVE
 15 AMPS & ABOVE TYPICAL CURVE

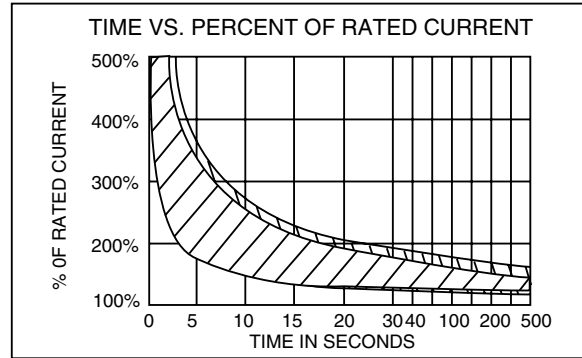

DIMENSIONS (Dims. shown are for reference only. Consult factory for latest prints) TERMINAL OPTIONS

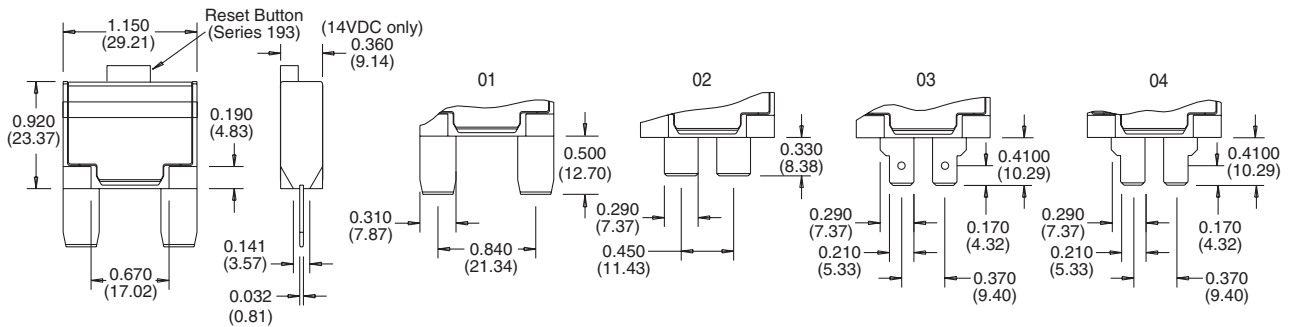

PART NUMBERING SYSTEM

Series	Rating	Terminal	Cover	Button (193 Series Only)	Marking
191 - Type I, 14 VDC	08 - 8 amps	01 - MAXI®	M - Metal*	1 - Black	(Consult factory for special markings.)
192 - Type II, 14 VDC	10 - 10 amps	02 - Wide ATC®	P - Plastic (193 only)	2 - White	
193 - Type III, 12V/28 VDC	15 - 15 amps	03 - Long ATC®			
194 - Type I, 28 VDC	20 - 20 amps	(w/dimple)			
195 - Type II, 28 VDC	25 - 25 amps	04 - Long ATC®			
	30 - 30 amps	(no dimple)			
	35 - 35 amps				
	40 - 40 amps				
	50 - 50 amps (191, 193, 194 only)				

* All breakers have metal cover except 193 series.

SERIES 3200 INSERTION/EXTRACTION TOOL

Series 3200

Automotive Fuse and
Circuit Breaker Insertion/Extraction Tool

FEATURES / BENEFITS

- **Custom Configurable Design**
Get Only the Extractors You Need
- **Common Platform for any Style**
Eliminates Design Changes When Protection Requirements Change
- **Center Snap-Lock Mounting Hole**
Easy Mounting Using Simple Split-Ball Snap-Lock Post
- **Positive Stop Locking Action**
Tight Grip Allows Devices to be Removed and Inserted
- **High Temperature Resilient Nylon 6/6 (105°C)**



DIMENSIONS (Dims. shown are for reference only. Consult factory for latest prints)

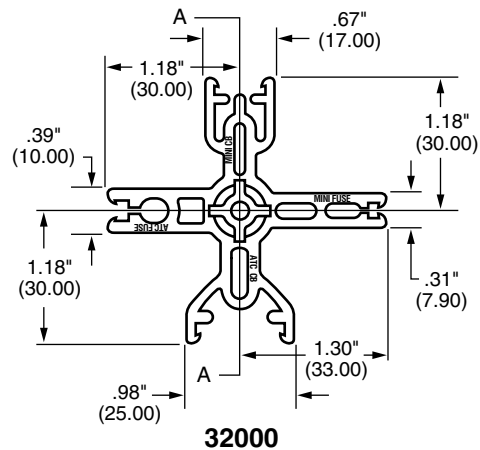
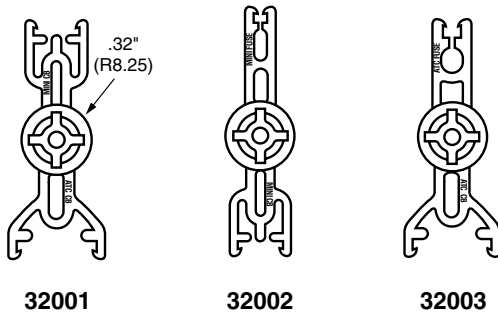

PART NUMBERING SYSTEM

Series

Configuration



Top	Right	Bottom	Left
0 - MINI CB	MINI FUSE	ATC® CB	ATC® FUSE
1 - MINI CB	BLANK	ATC® CB	BLANK
2 - MINI CB	BLANK	MINI FUSE	BLANK
3 - ATC® CB	BLANK	ATC® FUSE	BLANK

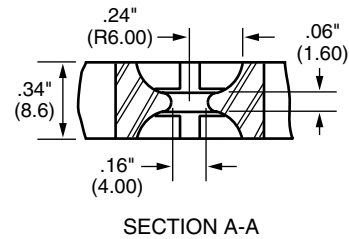

SERIES 32013

Series 32013

Automotive Fuse Circuit Breaker Insertion/Extraction Tool
(To be used with Series 32000
Dual Vehicle Electrical Center)

FEATURES / BENEFITS

- **Positive Stop Locking Action**
Tight Grip Allows Devices to be Removed and Inserted.
- **High Temperature Resilient Nylon 6/6 (105°C)**

PART NUMBERING SYSTEM

Series

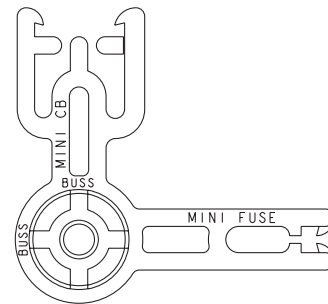

SERIES 174 FLAT-PAK CIRCUIT BREAKER



MANUAL RESET CIRCUIT BREAKERS

SPECIFICATIONS

Single Pole Thermal Type Breakers

Applications: Branch circuit protection for multiple power outlet strips, trucks, RV's, boats, buses, portable generators, building equipment, etc.

Rating: 5-40A; 250VAC/32VDC.

Interrupt Rating: 200A @ 250VAC.

Operating Temperature Rating: -40°F (-40°C) to 185°F (85°C).

Storage Temperature Rating: -40°F (-40°C) to 260°F (125°C).

Materials: Grey UL-Rated 94V-0 thermoplastic.

Termination: Threaded or quick-connect options available.

Ingress Protection Rating: IP54 (except at terminals).

Compliances: UL 1077 & CSA 22.2 No. 235 (See individual terminal styles for specific rating approvals); SAE J553; SAE J1171 (Ignition Protected).

DIMENSIONS (Dims. shown are for reference only. Consult factory for latest prints)

TERMINAL / BASE STYLES

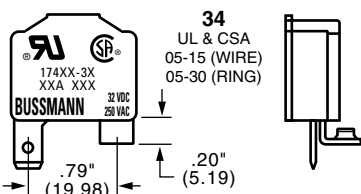
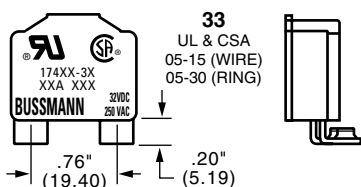
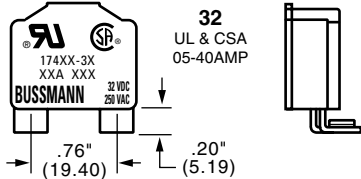
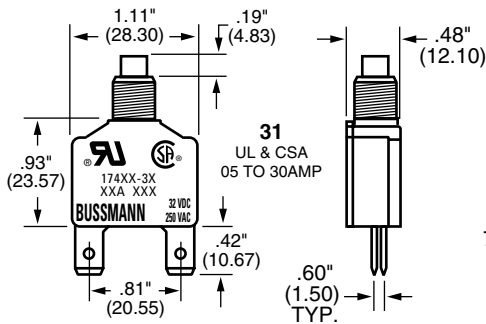

BUSHING / NECK STYLES

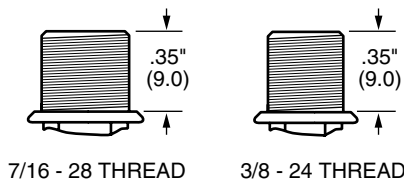

BUTTON MARKING OPTIONS

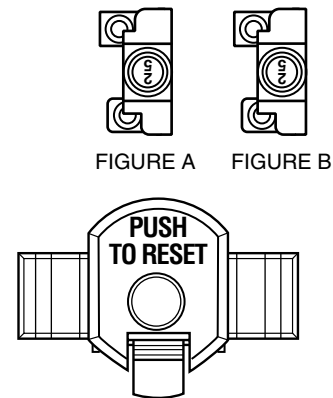

SNAP - ON

HARDWARE VARIATIONS

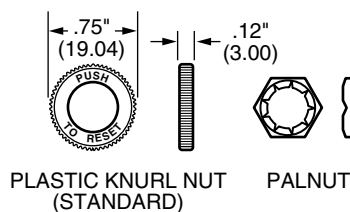

RECOMMENDED BUSHING PANEL CUTOUT

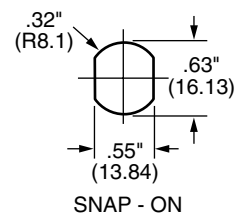
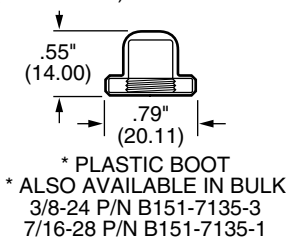
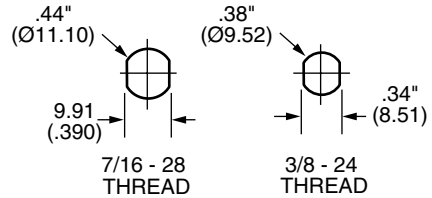

SERIES 174 FLAT-PAK CIRCUIT BREAKER

Temperature Derating Curves for 5-40 Amp. Circuit Breakers
174 SERIES TEMP. VS. CURRENT CURVES

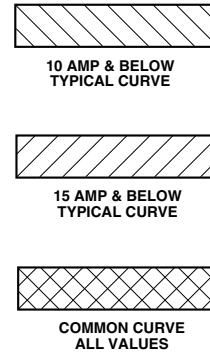
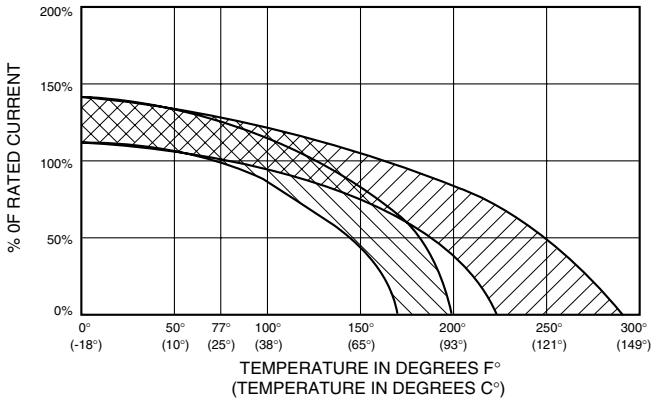

TIME vs. Percent of Rated Current Curves for 5-40 Amp. Circuit Breakers
174 SERIES TRIP CURVES

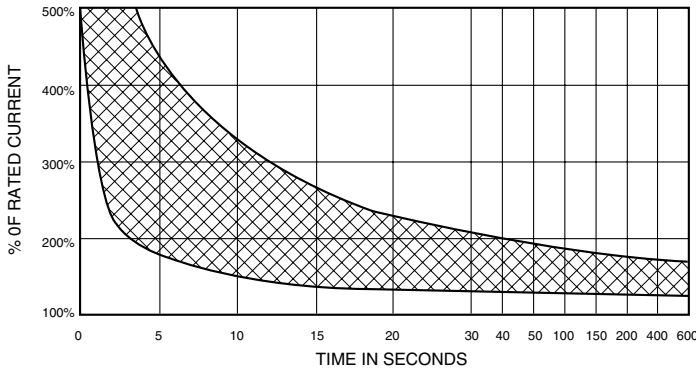

PART NUMBERING SYSTEM

Series	Rating	Terminal/ Base	Bushing/ Neck	Button	Hdwr. Pkg.	Bushing Hdwr.	Special Options
174	3						
174 – Type III 250 VAC/ 32VDC Manual Reset	05 – 5 amps 06 – 6 amps 07 – 7 amps 08 – 8 amps 10 – 10 amps 15 – 15 amps 20 – 20 amps 25 – 25 amps 30 – 30 amps 35 – 35 amps* 40 – 40 amps*	1 – .25" Quick Connect 2 – 10-32 screw - 90° bend 3 – 6-32 screw - 90° bend 4 – .25" Quick Connect with 6-32 screw - 90° bend	1 – 7/16-28 thread 2 – 3/8-24 thread 3 – Snap-on	A – White w/no marking B – Red w/no marking C – Black w/no marking** D – White w/amp marking Fig. A E – White w/amp marking Fig. B F – Red w/amp marking Fig. A G – Red w/amp marking Fig. B	1 – Pack bulk (standard) 2 – Assemble to bushing 3 – No hardware included	A – White plastic knurl nut, anti-rotational B – Black plastic knurl nut, anti-rotational C – White plastic knurl nut, anti-rotational w/ palnut D – Black plastic knurl nut, anti-rotational w/ palnut E – None required for bushing F – Zinc plated steel palnut G – Button boot (thread-on) w/ palnut P – Aluminum knurl nut & palnut R – Black aluminum knurl nut & palnut S – Alum. knurl nut, palnut, black plate w/ white "push-to-reset" T – Alum. knurl nut, palnut, white plate w/ black "push-to-reset" V – Alum. knurl nut & white plate w/ black "push-to-reset" W – Alum. knurl nut & black plate w/ white "push-to-reset" X – Aluminum knurl nut & internal tooth lockwasher Z – Hex nut & internal tooth lockwasher	0 – No hardware 1 – Bulk brass screws for screw terminals 2 – Bulk brass screws and lock- washers for screw terminals 3 – Assembled brass screws for screw terminals 4 – Assembled brass screws and lock- washers for screw terminals
	*2 or 3 Style Terminal Only.			**No marking available on Black buttons			

SERIES 12X SHORTSTOP® CIRCUIT BREAKERS

AUTO, MANUAL & MODIFIED RESET CIRCUIT BREAKERS

SPECIFICATIONS

Single Pole Thermal Type Breakers

Applications: Battery chargers, trucks, buses, RV's, trolling motors, etc.

Rating: 5-50A, 14VDC; 28VDC (Series 123, 124, & 125).

Interrupt Rating: Main Circuit Protection: 1.5kA @ 12VDC (Series 193 w/plastic cover); Branch Circuit Protection: 2.5kA @ 12VDC (Series 121 & 124 -01 sealed & Series 123 w/plastic cover).

Operating Temperature Rating: -40°F (-40°C) to 185°F (85°C).

Storage Temperature Rating: -40°F (-40°C) to 260°F (125°C).

Materials: Black UL-Rated thermoplastic body (thermoset for Type II body & buttons); Cover is grey thermoplastic or steel-Type I gold, Type II silver.

Marking: Custom marking available. Consult factory for options.

Termination: #10-32 thread and quick-connect options available.

Torque Rating: 24in-lb (2.7Nm) max.

Mounting Torque Rating: Plastic cover - 15in-lb (1.7Nm); Metal cover - 30in-lb (3.4Nm).

Ingress Protection Rating: IP66 on plastic cover version only (except for terminals).

Compliances: SAE J553; SAE J1171 (consult factory for Ignition Protection ratings).



TERMINAL OPTIONS

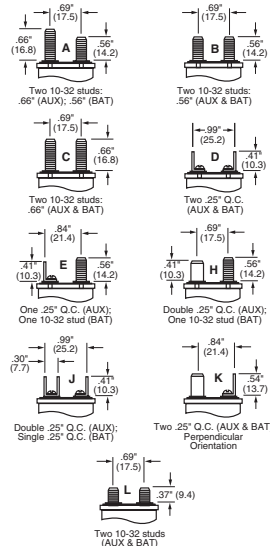

COVER & BRACKET OPTIONS (Dims. shown are for reference only. Consult factory for latest prints)

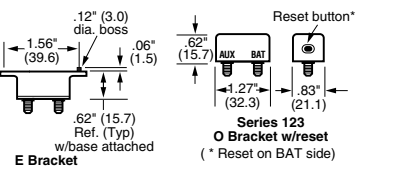
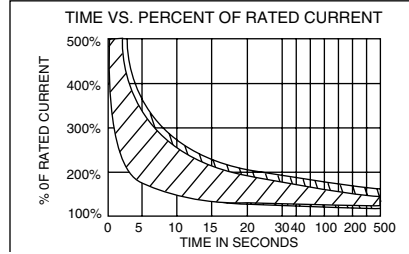
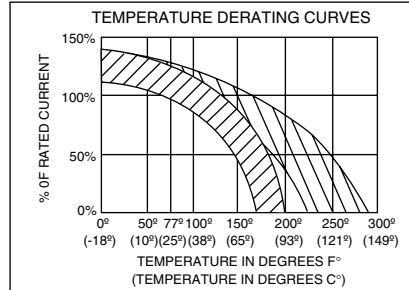
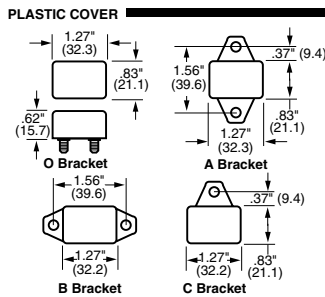
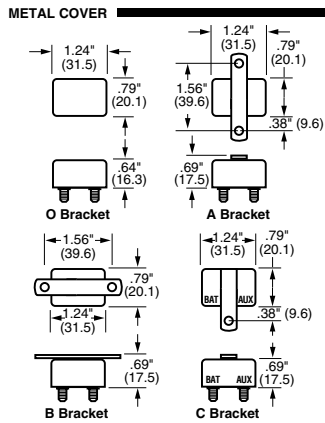

HARDWARE

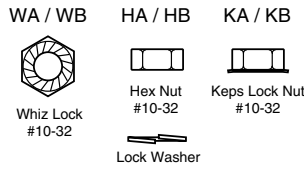

PART NUMBERING SYSTEM

Series	Terminal	Rating	Bracket	Mtg. Holes	Cover*	Options	Hardware
121 - Type I, 14 VDC	A - Two 10-32 studs; .66 (Aux), .56 (Bat)	05 - 5 amps	0 - No bracket	0 - No bracket	M - Metal*	01 - Waterproof (metal covers only)	WA - Whiz-lock nut assembled
122 - Type II, 14 VDC	B - Two 10-32 studs; .56 (Aux & Bat)	08 - 8 amps	A - Bracket	1 - .140 dia.	P - Plastic*		WB - Whiz-lock nut bulk
123 - Type III, 28 VDC	C - Two 10-32 studs; .66 (Aux & Bat)	10 - 10 amps	B - Bracket	2 - .196 dia.		02 - Splashproof (optional on metal covers - add 02 suffix; std. on plastic covers - omit 02 suffix.)	HA - Nut & lock washer assembled
124 - Type I, 28 VDC	***D - Two .250 QC; (Aux & Bat)	12 - 12 amps	C - Bracket	3 - .237 dia. (metal only)			HB - Nut & lock washer bulk
125 - Type II, 28 VDC	**H - One 10-32 stud .56 (Bat), Double .250 QC (Aux)	15 - 15 amps	E - Bracket (plastic only)	4 - .265 dia. (plastic only)			KA - Keps lock nut assembled
	L - Two 10-32 studs; .37 (Aux & Bat)	20 - 20 amps		5 - .228 dia. (plastic only)			KB - Keps lock nut bulk
		25 - 25 amps		6 - .221 dia. (metal only)			
		30 - 30 amps					
		35 - 35 amps					
		40 - 40 amps					
		50 - 50 amps					

*Series 123 available in plastic cover only. Series 122 & 125 available in metal cover only. **40A maximum ***30A maximum

SERIES 25X MID-RANGE CIRCUIT BREAKER

NEW



MANUAL RESET CIRCUIT BREAKERS

Automatic, Manual, & Manual W/ Push-to-Trip

SPECIFICATIONS

Single Pole Thermal Type Breakers

Applications: This unit is external ignition protected and weatherproof. It is typically used in DC power systems in marine applications (as a main or branch circuit breaker), truck, bus and RV systems, add-on protection for accessories, etc.

Rating: 10-50A, 32VDC.

Interrupt Rating: Circuit Protection (2.5kA) per ABYC E-11.

Operating Temperature Rating: -40°F (-40°C) to 185°F (85°C).

Storage Temperature Rating: -40°F (-40°C) to 260°F (125°C).

Materials: Black UL-Rated 94V-0 thermoset plastic body. Cover, lever, and button are UL-Rated 94V-0 thermoplastic. Cover has a black thermoplastic elastomer overmold.

Marking: Standard marking includes amp/volt ratings, part numbers, and "SAE Type B."

Termination: #10-32 threaded studs.

Torque Rating: 24in-lb (2.7Nm) max.

Mounting Torque Rating: Panel mount with either #8-32 threaded inserts or #10 clearance holes. 18in-lb (2.0Nm) max.

Ingress Protection Rating: IP66

Features / Options: Series 254 & 255 have a unique reset mechanism which provides a visual indication of tripped condition. Series 255 also features a push-to-trip option.

Compliances: SAE J553; ABYC E-11; SAE J1171 (Ignition Protected).

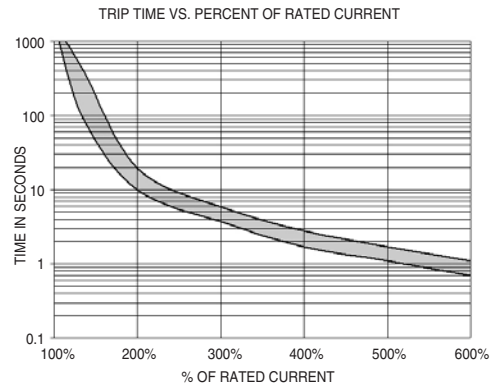
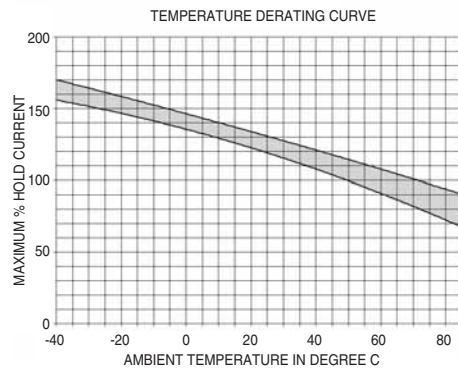

DIMENSIONS (Dims. shown are for reference only. Consult factory for latest prints)

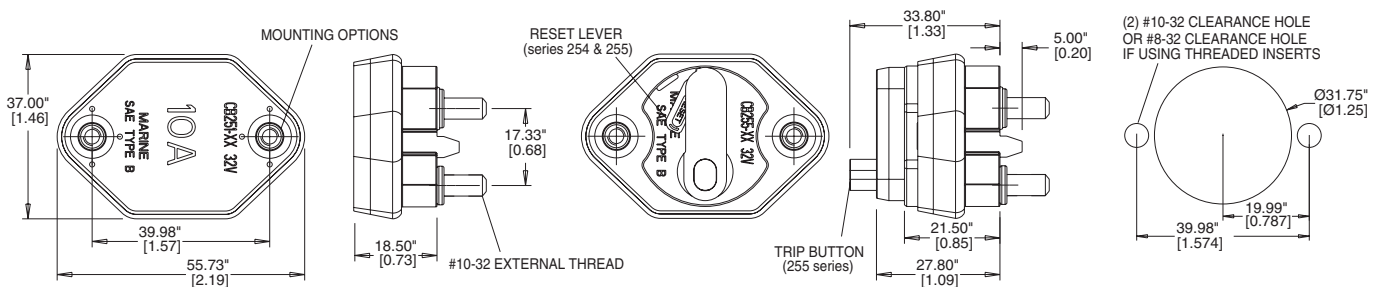

PART NUMBERING SYSTEM

Series



251 - Type I, 32V
 254 - Type III, 32V
 255 - Type III w/push-to-trip option, 32V

Rating



10 - 10 amps
 15 - 15 amps
 20 - 20 amps
 25 - 25 amps
 30 - 30 amps
 35 - 35 amps
 40 - 40 amps
 50 - 50 amps

Mounting Holes



A - Thru-hole Insert (#10 Clearance)
 B - #8-32 Threaded Inserts

Hardware



0 - No nuts
 1 - Nuts Installed
 2 - Nuts bulk

SERIES 18X HI-AMP CIRCUIT BREAKER

AUTO, MANUAL & SWITCHABLE RESET CIRCUIT BREAKERS

SPECIFICATIONS

Single Pole Thermal Type Breakers

Applications: Typically used in auxiliary and accessory circuits in truck, bus, RV and marine systems. Others include battery chargers and DC audio systems. Series 181, 184 & 185 are sealed for engine compartment and bilge area applications.

Rating: 25-150A, 30VDC; 48VDC (Series 184 & 185).

Interrupt Rating: 3,000A @ 30VDC.

Operating Temperature Rating: -25°F (-32°C) to 180°F (82°C).

Storage Temperature Rating: -30°F (-34°C) to 300°F (149°C).

Materials: Black UL-Rated 94V-0 thermoset plastic. Thermoplastic elastomer stud insulators are provided on covered units with F-style (surface-mount) bases.

Marking: Standard marking includes amp ratings and part numbers. Custom markings also available.

Termination: 1/4-28 threaded studs.

Torque Rating: 50in-lb (5.6Nm) max.

Mounting Torque Rating: Panel or surface-mount options; 50in-lb (5.6Nm) max.

Threaded insert option has a max torque of 25in-lb (2.8Nm).

Ingress Protection Rating: IP67.

Features / Options: Series 184 & 185 have a unique reset mechanism which provides visual indication of tripped condition. Series 185 also features a push-to-trip option.

Compliances: SAE J1625; ABYC E-11; CE; SAE J1171 (Ignition Protected).



DIMENSIONS (Dims. shown are for reference only. Consult factory for latest prints)

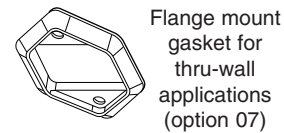
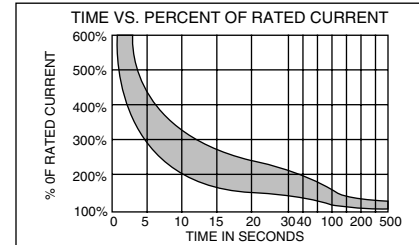
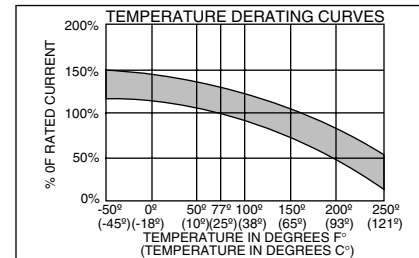
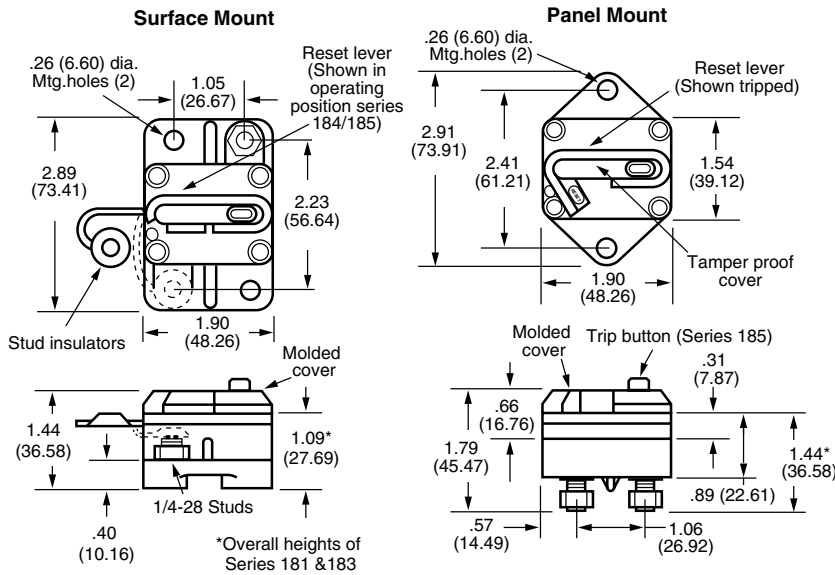

PART NUMBERING SYSTEM

Series	Rating	Mounting	Terminal Hdwr.	Marking
1 8				
181 - Type I, 30V	025 - 25 amps	F - Surface Mount	00 - Ship w/o nuts	0 - Blank cover
183 - Type II*, 30V	030 - 30 amps	P - Panel Mount	01 - Sems nuts installed	1 - Standard Marking; Part Number, Amp Rating
184 - Type III, 48V	035 - 35 amps		02 - Sems nuts shipped bulk	181, 184, 185 Series - Top Surface
185 - Type III-PTT, 48V	040 - 40 amps		03 - Stainless Steel Std. nuts & washers installed	183 Series - Side Surface
	050 - 50 amps		04 - Stainless Steel Std. nuts & washers shipped bulk	S - Standard Ignition Protected Marking
	060 - 60 amps		07 - Flange gasket & Sems nuts installed (Panel Mount Only)	(Consult factory for special markings.)
	070 - 70 amps		08 - Threaded insert and Sems nuts installed	
	080 - 80 amps		12 - Stainless steel nuts and lockwashers installed	
	090 - 90 amps		13 - Stainless steel Sems nut installed	
	100 - 100 amps			
	110 - 110 amps			
	120 - 120 amps			
	135 - 135 amps			
	150 - 150 amps			

*183 Available in Panel Mount Only (Coverless)

SERIES 187 MARINE RATED CIRCUIT BREAKER (MRCB)

MANUAL RESET CIRCUIT BREAKERS WITH SWITCH FUNCTION

SPECIFICATIONS

Single Pole Thermal Type Breakers

Applications: Typically used in DC power systems in marine applications (as a main or branch circuit breaker), truck and bus systems, RV systems, add-on protection for accessories, lift gates, etc. This unit is external ignition protected and weatherproof.

Rating: 25-150A, 48VDC.

Interrupt Rating: Main Breaker Protection Interrupt Rating (5kA @ 12VDC). (Consult factory for higher voltage interrupt ratings.)

Operating Temperature Rating: -40°F (-40°C) to 185°F (85°C).

Storage Temperature Rating: -40°F (-40°C) to 260°F (125°C).

Materials: Black UL-Rated 94V-0 thermoset plastic body. Cover and lever are UL-Rated 94V-0 thermoplastic.

Marking: Standard marking includes amp/volt ratings. Custom markings also available.

Termination: 5/16-18 threaded studs.

Torque Rating: 75in-lbs (8.5Nm) max.

Mounting Torque Rating: Panel or surface-mount options; 50in-lb (5.6 Nm) max.

Ingress Protection Rating: IP66.

Features / Options: A manual reset circuit breaker with On-Off switch capability.

Compliances: ABYC E-11; CE; SAE J1171 (Ignition Protected).

Consult factory for time characteristic curves.



DIMENSIONS (Dims. are shown for reference only. Consult factory for latest prints)

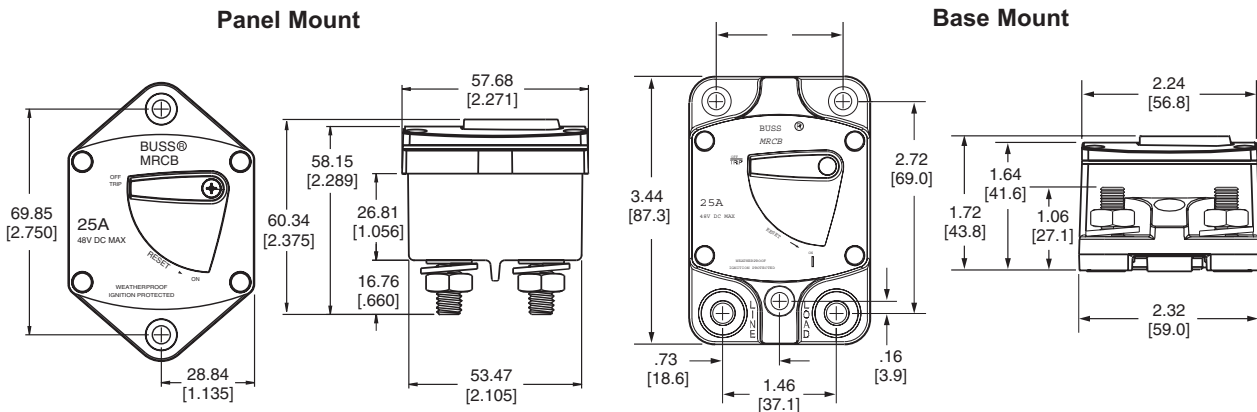

PART NUMBERING SYSTEM

Series	Rating	Mounting	Hardware	Marking
187	25	P	00	1
187 - Manual Reset - Switching Style Circuit Breaker	025 - 25 amps 030 - 30 amps 035 - 35 amps 040 - 40 amps 050 - 50 amps 060 - 60 amps 070 - 70 amps 080 - 80 amps 100 - 100 amps 110 - 110 amps 120 - 120 amps 135 - 135 amps 150 - 150 amps	F - Surface mount P - Panel mount	00 - No hardware 03 - Stainless nuts & lockwashers - installed on studs 04 - Stainless nuts & lockwashers - supplied bulk packed	1 - Standard marking; Part Number, Amp Rating (Consult factory for special marking options.)

AMI SERIES

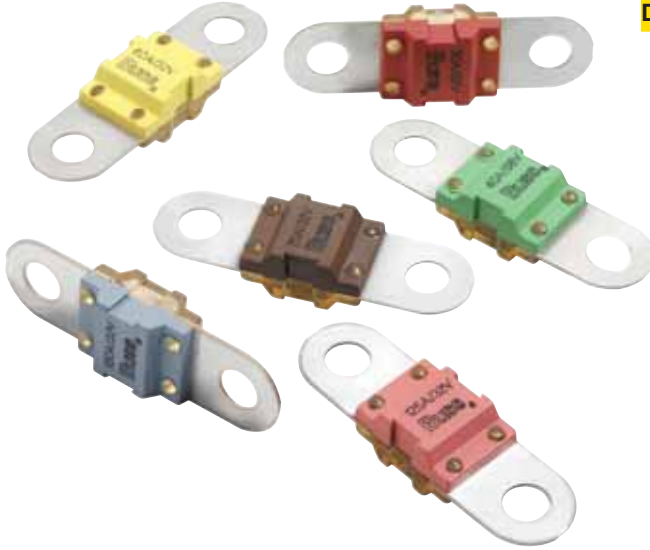

DIMENSIONS (Dims. shown are for reference only. Consult factory for latest prints)

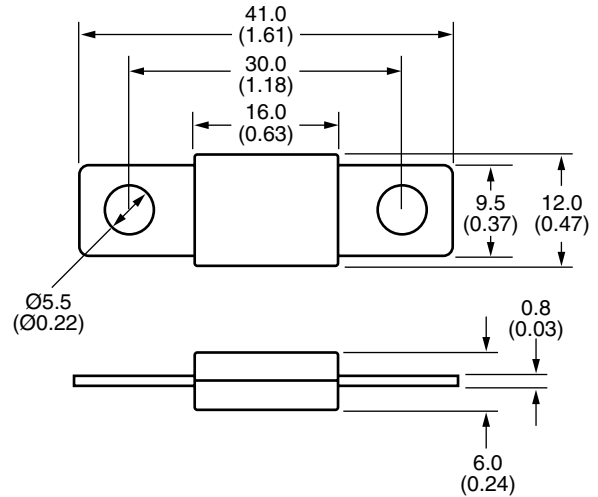

BOLT IN AUTOMOTIVE FUSES

SPECIFICATIONS:

Applications: Power distribution protection for automotive systems. Consult factory for available fuse-holders.

Current Rating: 30-150A.

Voltage Rating: 32VDC.*

Interrupt Rating: 2000A @ 32VDC.

Housing Material: UL-Rated 94V-0 thermoplastic.

Terminal Material: Tin-plated brass.

Mounting: Max torque of 35in-lb (4Nm).

Marking: Color-coded housings for each amperage.

*Consult factory for higher voltage fuses.

TIME-CURRENT SPECIFICATIONS

% of Rating	Opening Time	
	Minimum	Maximum
100	100 hrs	
110	4 hrs	
150	90 s	3600 s
200	5 s	100 s
300	0.3 s	10 s
500	0.1 s	1 s

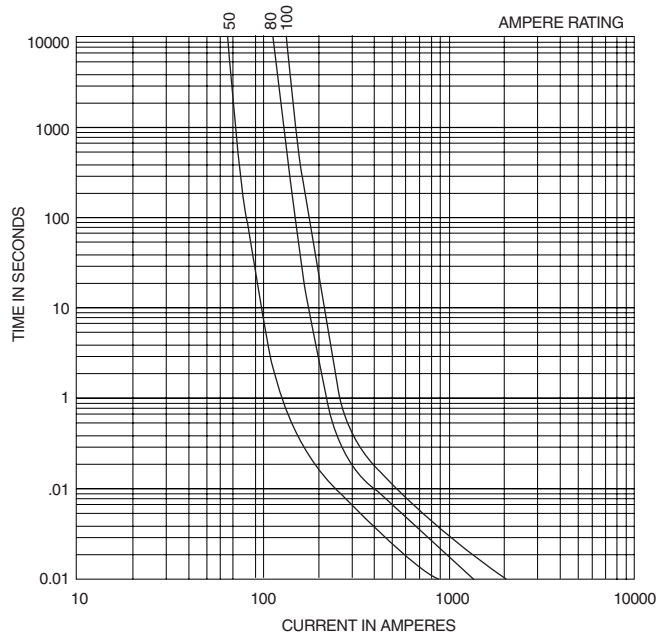

PART NUMBERING SYSTEM

Series

B **K** / **A** **M** **I** - **□** **□** **□**

Rating

- 030 - 30 amps (orange)
- 040 - 40 amps (lt. green)
- 050 - 50 amps (red)
- 060 - 60 amps (yellow)
- 070 - 70 amps (brown)
- 080 - 80 amps (white)
- 100 - 100 amps (blue)
- 125 - 125 amps (pink)
- 150 - 150 amps (gray)

AMG SERIES



DIMENSIONS (Dims. are shown for reference only. Consult factory for latest prints)

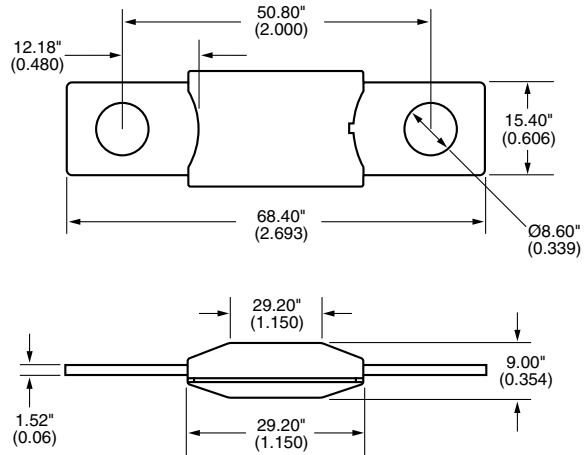

BOLT IN AUTOMOTIVE FUSES

SPECIFICATIONS:

Applications: For high current applications. Use with Bussmann HMG or FMG fuseholders. (See pages 12-13.)

Current Rating: 100-300A.

Voltage Rating: 32VDC.*

Interrupt Rating: 1,000A @ 32VDC.

Housing Material: UL-Rated 94V-0 thermoplastic.

Terminal Material: Copper.

Mounting: M8 or 5/16-18 or less studs on 2.00 in (50.8mm) centers.

Marking: Color-coded amperage ratings.

*Consult factory for higher voltage fuses.

TIME-CURRENT SPECIFICATIONS

% of Rating	Opening Time	
	Minimum	Maximum
100	100 hrs	
135	120 s	1800 s
200	1 s	30 s
350	0.1 s	5 s
600	0.02 s	1 s

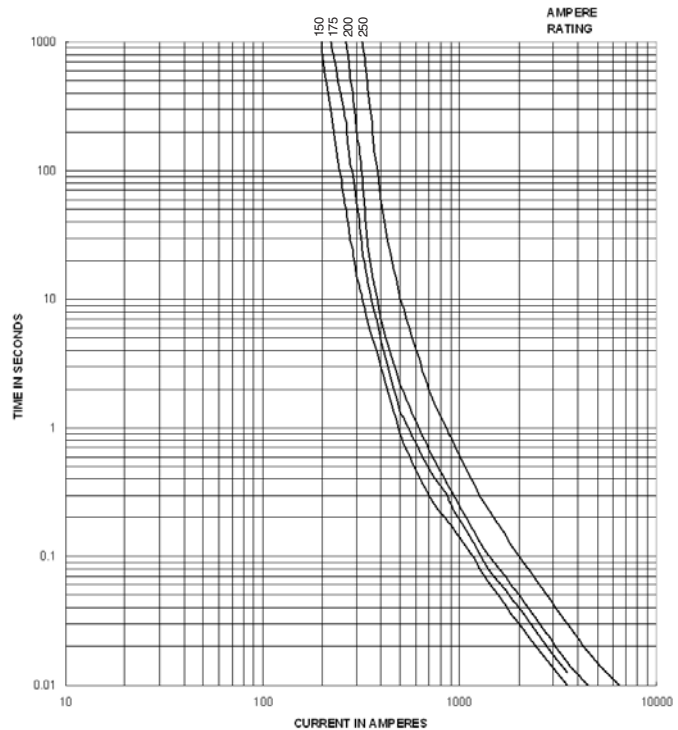

PART NUMBERING SYSTEM

Series

B K / A M G — □ □ □

Rating

- 100 – 100 amps
- 125 – 125 amps
- 150 – 150 amps
- 175 – 175 amps
- 200 – 200 amps
- 225 – 225 amps
- 250 – 250 amps
- 300 – 300 amps

NOTES



COOPER Bussmann

Transportation Products

Cooper Bussmann
P. O. Box 14460
St. Louis, Missouri 63178-4460
Telephone: 636-394-2877
Facsimile: 800-544-2570

**Cooper Bussmann
Transportation Products**
175 Hansen Court
Wood Dale, IL 60191-1145
Telephone: 888-867-8194
Facsimile: 800-832-9873

**European Headquarters
Cooper Bussmann U.K. Ltd.**
Burton-on-the-Wolds
Leicestershire LE12 5 TH
England
Telephone: 44-1509-882737
Facsimile: 44-1509-882786

**Cooper Bussmann
Thomas A. Edison R&D
Center (Shanghai)Co.,Ltd.**
955 Sheng Li Road
Heqing Pudong, Shanghai
China 201201
Telephone: +8621 2899 3747
Facsimile: +8621 2899 3997

Cooper Electrical Australia
205-209 Woodpark Road
P.O. Box 2577
Smithfield, Sydney
NSW 2163, Australia
Telephone: 61-2-8787-2700
Facsimile: 61-2-9609-2342

Cooper Bussmann India Ltd.
EVR Street, Sedarapet
Pondicherry - 605 111 India
Telephone: 91-80-227-0893
Facsimile: 91-80-224-5725

Bussmann do Brazil Ltd.
Rodovia Santos Dumont, Km 23
Cruz das Almas - 13.300-000
Caixa Postal 095
Itu-Sao Paulo Brazil
Telephone: 55-11-4024-8400
Facsimile: 55-11-4024-8424

**Bussmann Transportation
Products Authorized Sales
Office, Mexico**
Kruvand and Associates
1202 Richardson Drive,
Suite 113
Richardson, Texas 75080
Telephone: 972-437-3355
Facsimile: 972-680-8854

Bussmann®

Solutions for the Transportation Industry

COOPER BUSSMANN • 175 HANSEN COURT • WOOD DALE, IL 60191-1145
CUSTOMER SATISFACTION PHONE: (888) 867-8194 • TECHNICAL SUPPORT PHONE: (888) 478-8324 • FAX: (800) 832-9873
WEB SITE: www.coopertp.com



Компания «ЭлектроПласт» предлагает заключение долгосрочных отношений при поставках импортных электронных компонентов на взаимовыгодных условиях!

Наши преимущества:

- Оперативные поставки широкого спектра электронных компонентов отечественного и импортного производства напрямую от производителей и с крупнейших мировых складов;
- Поставка более 17-ти миллионов наименований электронных компонентов;
- Поставка сложных, дефицитных, либо снятых с производства позиций;
- Оперативные сроки поставки под заказ (от 5 рабочих дней);
- Экспресс доставка в любую точку России;
- Техническая поддержка проекта, помощь в подборе аналогов, поставка прототипов;
- Система менеджмента качества сертифицирована по Международному стандарту ISO 9001;
- Лицензия ФСБ на осуществление работ с использованием сведений, составляющих государственную тайну;
- Поставка специализированных компонентов (Xilinx, Altera, Analog Devices, Intersil, Interpoint, Microsemi, Aeroflex, Peregrine, Syfer, Eurofarad, Texas Instrument, Miteq, Cobham, E2V, MA-COM, Hittite, Mini-Circuits, General Dynamics и др.);

Помимо этого, одним из направлений компании «ЭлектроПласт» является направление «Источники питания». Мы предлагаем Вам помощь Конструкторского отдела:

- Подбор оптимального решения, техническое обоснование при выборе компонента;
- Подбор аналогов;
- Консультации по применению компонента;
- Поставка образцов и прототипов;
- Техническая поддержка проекта;
- Защита от снятия компонента с производства.



Как с нами связаться

Телефон: 8 (812) 309 58 32 (многоканальный)

Факс: 8 (812) 320-02-42

Электронная почта: org@eplast1.ru

Адрес: 198099, г. Санкт-Петербург, ул. Калинина, дом 2, корпус 4, литера А.