

Solid-state, Plug-in Current Sensor

- Applicable to motor overcurrent protection and 3-phase AC current detection.
- Inverse-type, start-up lock type, and instantaneous type overcurrent sensors available.
- Instantaneous type under current sensor available.
- Plug-in design simplifies installation, removal, and wiring.
- DIN sized (48 mm x 96 mm)



The SAO cannot be used in circuits with waveform distortion, inverter circuits, or with capacitor loads.



Model Number Structure

Model Number Legend

SAO-□□□□

1 2 3 4 5

1. Basic model name

SAO: Current Sensor

2. Operating time characteristics

R: Inverse type: inverse time both at starting and during operation

Q: Instantaneous type with start-up lock

S: Regular instantaneous type

3. Detection function

U: Undercurrent detection

None: Overcurrent detection

4. Control voltage

1: 100/110/120 VAC

2: 200/220/240 VAC

5: 24 VDC

6: 48 VDC

7: 100/110 VDC

5. Product history

N: New version

Ordering Information

Terminal/ mounting	Control voltage	Overcurrent detection			Under current detection
		Inverse type	Instantaneous type		Instantaneous type
			W/start-up lock*	W/o start-up lock	
Plug-in/DIN rail via socket	100/110/120 VAC	SAO-R1N	SAO-Q1N	SAO-S1N	SAO-SU1N
	200/220/240 VAC	SAO-R2N	SAO-Q2N	SAO-S2N	SAO-SU2N
	24 VDC	SAO-R5N	SAO-Q5N	SAO-S5N	SAO-SU5N
	48 VDC	SAO-R6N	SAO-Q6N	SAO-S6N	SAO-SU6N
	100/110 VDC	SAO-R7N	SAO-Q7N	SAO-S7N	SAO-SU7N

* Fixed time-limit at start-up, instantaneous thereafter.

Accessories (Order Separately)

Current Converters

Model	Current range
SET-3A	1 to 80 A
SET-3B	64 to 160 A

DIN rail socket
8PFA1

Socket

Type	Model
Front connecting socket	8PFA1

Specifications

■ Ratings

Motor circuit	Voltage: 500 VAC max. 3-phase (primary voltage at SET Current Converter) Current: 1 to 80 A or 64 to 160 A 3-phase (primary current at SET Current Converter)
Power supply circuit	Voltage: 100/110/120 VAC, 200/220/240 VAC, 24, 48 VDC, or 100/110 VDC (leveled DC) Voltage fluctuation: $+10/-15\%$ max. of the rated voltage Frequency: 50/60 Hz $\pm 5\%$
Current SV range	See table of <i>Current Converter</i> .
Output contact	Configuration: SPDT Capacity: 3 A ($\cos\phi = 1.0$)/2 A ($\cos\phi = 0.4$) at 240 VAC; 3 A (resistive load)/2 A (L/R = 7 ms) at 24 VDC; 0.2 A (resistive load)/0.1 A (L/R = 7 ms) at 110 VDC
Power consumption	100/110/120 VAC: approx. 3.5 VA; 200/220/240 VAC: approx. 7 VA; 24 VDC: approx. 0.3 W; 48 VDC: approx. 0.5 W; 100/110 VDC: approx. 1.2 W
Case color	Munsell 5Y7/1

■ Characteristics

Item	SAO-R□N	SAO-Q□N	SAO-S□N	SAO-SU□N
Operating current	100% of the current SV (current when the relay is OFF for the SAO-SU□N)			
Operating time characteristics	Inverse type	Fixed time at start-up and instantaneous thereafter	Instantaneous type	
Operating time	For a 600% overcurrent: Time scale x 1: 1 to 10 s Time scale x 4: 4 to 40 s For a 200% overcurrent: 2.8 x t $\pm 30\%$, where t is the operating time at 600% overcurrent. (time SV at max.)	In start-up lock mode with a 600% overcurrent: Time scale x 1: 1 to 10 s Time scale x 4: 4 to 40 s In instantaneous mode: 0.3 s max. at 120% overcurrent	0.3 s max. with an overcurrent of 120% the current SV	0.3 s max. when 120% the current SV drops below 80%
Initial current in start-up mode	---	Approx. 30% of the current SV	---	---
Inertial characteristics	Will not operate for 80% of operating time for a 600% overcurrent. (at min. current and max. time SV)	---		
Reset value	More than 95% of the operating current			Less than 105% of the operating current
Operating current accuracy	$\pm 10\%$ of the current SV			
Operating time accuracy	$+10/-5\%$ of maximum time SV (at a time SV: 1) $\pm 10\%$ of maximum time SV (at a time SV: 2 to 10)		0.3 s max.	
Influence of temperature on operating current	$\pm 5\%$ for 0 to 40°C; $\pm 10\%$ for -10 to 50°C			
Influence of temperature on operating time	$\pm 10\%$ for 0 to 40°C; $\pm 20\%$ for -10 to 50°C (start-up mode)		0.3 s max. for -10 to 50°C	
Influence of frequency on operating current	$\pm 3\%$ for a frequency fluctuation of $\pm 5\%$			
Influence of frequency on operating time	$\pm 5\%$ for a frequency fluctuation of $\pm 5\%$ (start-up mode)		0.3 s max. for a frequency fluctuation of $\pm 5\%$	
Influence of voltage on operating current	$\pm 3\%$ for a voltage fluctuation of $+10/-15\%$			
Influence of voltage on operating time	$\pm 5\%$ for a voltage fluctuation of $+10/-15\%$ (start-up mode)		0.3 s max. for a voltage fluctuation of $+10/-15\%$ (start-up mode)	

Characteristics (continued)

Insulation resistance	10 MΩ min. between electric circuits and the mounting panel 5 MΩ min. between contact circuits, or between contacts of same pole
Withstand voltage	2,000 VAC for 1 min between electric circuits and the mounting panel 2,000 VAC for 1 min between contact circuits and other circuits 1,000 VAC for 1 min between contacts of same pole
Lighting impulse withstand voltage	6,000 V max. between electric circuits and the mounting panel 4,500 V max. between contact circuits and other circuits 4,500 V max. between each control power circuits Waveform: 1.2 x 50 μs 3 times for each poles
Overload capacity	Motor circuit: 20 times the current SV for 2 s, applied twice with a 1 min interval Continuous current: 125% of the maximum current SV for each current range. Power supply: AC: 1.15 times the rated power supply voltage for 3 hrs, once DC: 1.3 times the rated power supply voltage for 3 hrs, once
Vibration resistance	Malfunction: 10 to 55 Hz, 0.3-mm double amplitude each in 3 directions for 10 min Destruction: 10 to 25 Hz, 2-mm double amplitude each in 3 directions for 2 hrs
Shock resistance	Malfunction: 98 m/s ² (approx. 10G) each in 3 directions Destruction: 294 m/s ² (approx. 30G) each in 3 directions
Test button operation	Operated quickly (without lighting the LED)
Ambient temperature	Operating: -10 to 60°C (with no icing) Storage: -25 to 65°C (with no icing)
Ambient humidity	Operating: 35% to 85%
Altitude	2,000 m max.
Weight	Approx. 170 g

Engineering Data

Operating Time Characteristics

SAO-R

Time Changeover Setting: 1

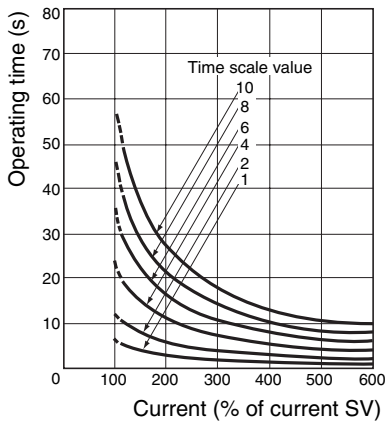

Time Changeover Setting: 4

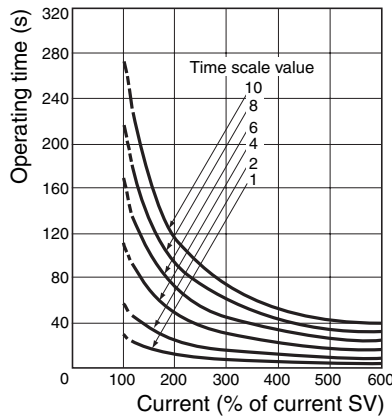

SAO-Q

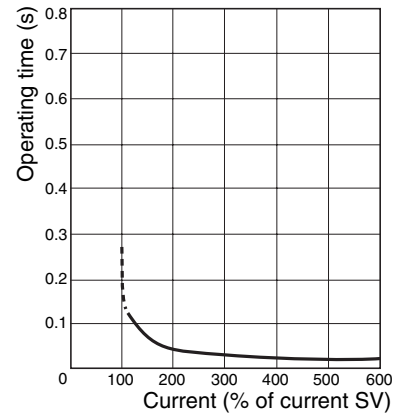

SAO-S

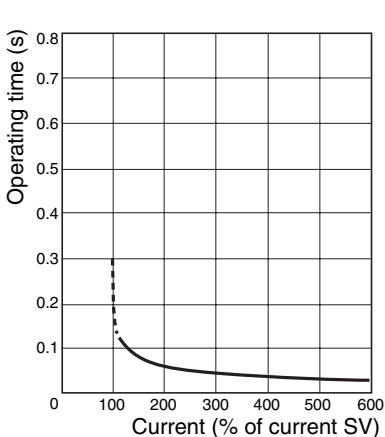

SAO-SU

Operating Time Characteristics

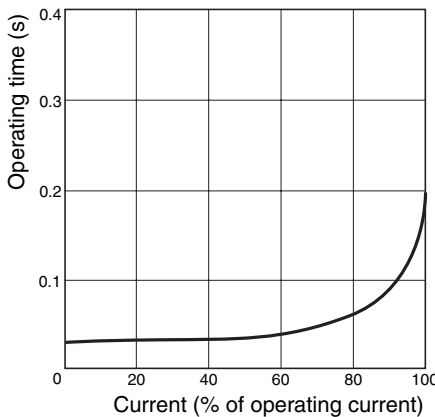

Reset Time Characteristics

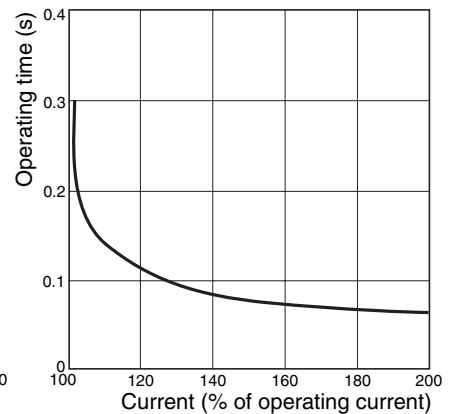

Installation

■ Connection

Internal Circuit

SAO-R

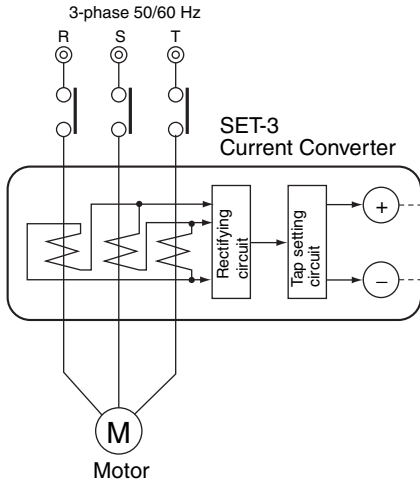

SAO-R Current Sensor

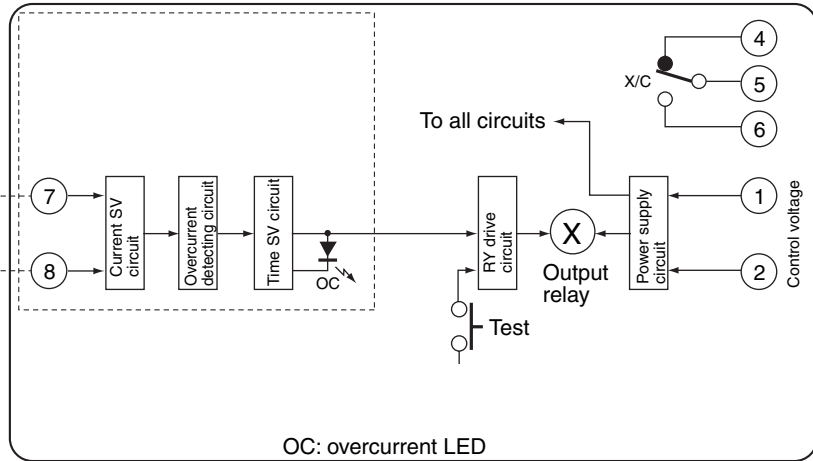

Note: There is no polarity specification when using a DC power supply.

SAO-Q Current Sensor

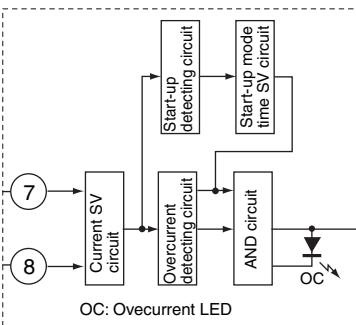

SAO-S Current Sensor

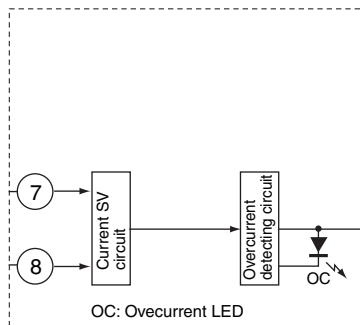

SAO-SU

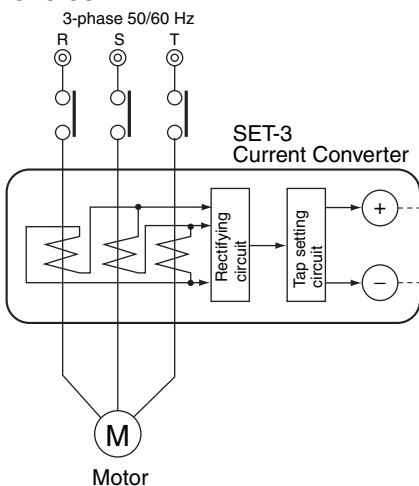

SAO-SU Current Sensor

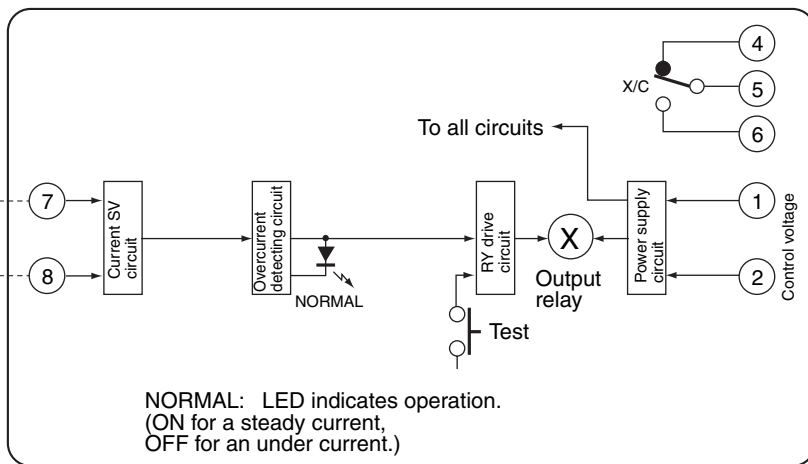

NORMAL: LED indicates operation.
(ON for a steady current, OFF for an under current.)

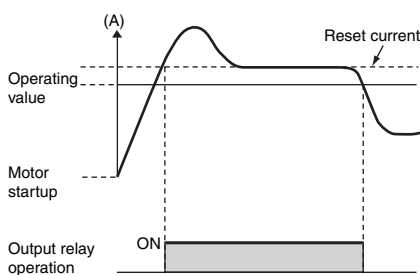

Explanation of SAO-SU Contacts

1. The contact is NC (between terminals 4 and 5) when the motor is not started.
2. The contact is NO (between terminals 5 and 6) when the startup pushbutton is pressed and a current larger than the reset current flows.
3. The contact is NC (between terminals 4 and 5) when the motor current is less than the operating value (i.e., undercurrent).

■ Connection Examples

Overcurrent Detection Circuit
SAO-R/SAO-Q/SAO-S

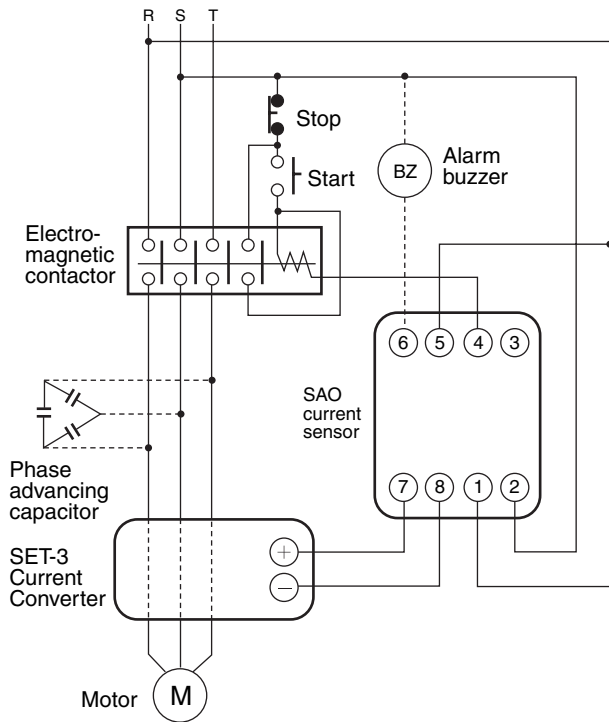

Note: Provide the control power supply for the SAO Current Sensor from the contactor's power supply side. If the control power supply is turned ON and the motor is started at the same time, operation inconsistent with the time SV may occur.

Undercurrent Detection Circuit
SAO-SU

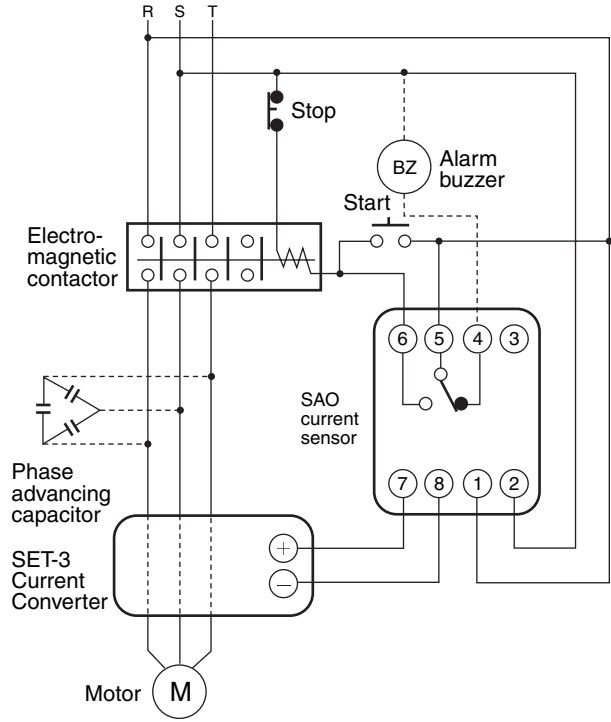

Note: To prevent the buzzer sounding when power is turned ON, install a timer so that the buzzer sounds only when the timer's contacts are closed.

Operation

Settings

Current Sensor Switch Settings

Current Scale Multiplying Factor Decal

Determine the current scale multiplying factor corresponding to the current SV range obtained from Table 1 and paste the current scale multiplying range decal to the current sensor. For example, when the current setting range is 2 to 5 A, the decal no. is 0.5.

Setting Operating Current

Set the current setting knob to the required current value. The setting value is indicated by the product of the scale value and the multiplying factor as shown in the following table. The required trip current can be obtained directly by means of the current-setting knob.

Decal no.	Current scale value (A)						
	4	5	6	7	8	9	10
0.25	1	1.25	1.5	1.75	2	2.25	2.5
0.5	2	2.5	3	3.5	4	4.5	5
1	4	5	6	7	8	9	10
2	8	10	12	14	16	18	20
4	16	20	24	28	32	36	40
8	32	40	48	56	64	72	80
16	64	80	96	112	128	144	160

LED Indicator

The LED indicates that an overcurrent has occurred and the relay is operating.

Setting Operating Time

Set the time setting knob to the required time. The operating time is equal to the time scale value times the setting on the time changeover switch. For example, if the time scale value is 6, and the time changeover switch is set to 4, the operating time is 24 s. For the SAO-R, this is the operating time in the event of a 600% overcurrent. For the SAO-Q, this is the operating time in start-up mode. There is no operating time SV for the SAO-S.

Test Button

Pressing the test button momentarily operates the output relay. The LED indicator, however, does not light during this operation.

SAO-R/Q

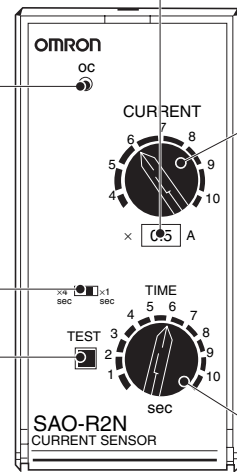

Time Setting Knob

SAO-S

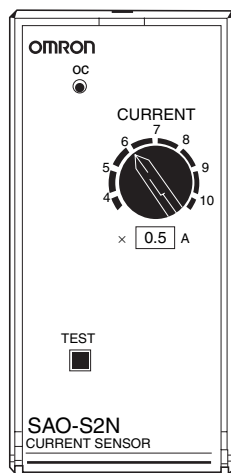

SAO-SU

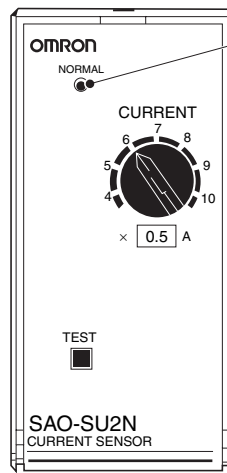

LED Indicator

The NORMAL indicator is lit for normal current; not lit for undercurrent.

Operating and Setting Procedures

SAO-R, -Q, -S

Make the settings for the SAO Current Sensor and the SET-3□ Current Converter according to the current of the load to be used.

Steady Current

Rated current (current setting range) (A)	Current scale multiplying factor label number	Current converter		
		Number of conductor passings	Setting tap	Model
1 to 2.5	0.25	8	20	SET-3A
2 to 5	0.5	4	20	
4 to 10	1	2	20	
8 to 20	2	1	20	
16 to 40	4	1	40	
32 to 80	8	1	80	
64 to 160	16	1	Fixed	SET-3B

Note: The current setting range is determined by the number of times the conductors to the SET-3□ are passed through and by the setting tap of the SET-3□. The current scale values are always 4 to 10 A. Therefore, attach the included current scale multiplying factor label to the SAO that matches the current range.

Determining Current Sensor Settings

1. Determining the Current Scale Multiplying Factor

Determine a current scale multiplying factor that matches the steady current obtained from the table, and attach that decal to the Current Sensor. For example, when the current setting range is 2 to 5 A, the label number is 0.5.

2. Setting the Operating Current

Determine the operating current setting from the required steady current and the label number (i.e., multiplying factor) and make the setting using the current setting knob. The following table shows the relation between scale values and actual operating current values.

Setting Factor	4	5	6	7	8	9	10
× 0.25	1	1.25	1.5	1.75	2	2.25	2.5
× 0.5	2	2.5	3	3.5	4	4.5	5
× 1	4	5	6	7	8	9	10
× 2	8	10	12	14	16	18	20
× 4	16	20	24	28	32	36	40
× 8	32	40	48	56	64	72	80
× 16	64	80	96	112	128	144	160.5

The figures are steady current values. (Unit: A)

3. LED Operation Indicator

The indicator is continuously lit when the Sensor operates due to overload.

Note

After detection, the operation indicator automatically turns OFF when there is no longer an overload.

4. Setting the Operating Time

- Set the time setting knob to the required time. The operating time is equal to the scale value times scale multiplying factor.
- The scale value can be selected using the changeover switch. For the SAO-R, this is the operating time in the event of a 600% overcurrent. For the SAO-Q, this is the operating time in startup mode. There is no operating time SV for the SAO-S.

Scale multiplying factor	Time scale value	
	× 1	× 4
1	1 s	4 s
2	2 s	8 s
3	3 s	12 s
4	4 s	16 s
5	5 s	20 s
6	6 s	24 s
7	7 s	28 s
8	8 s	32 s
9	9 s	36 s
10	10 s	40 s

5. Test Button

Pressing the button momentarily operates the output relay. The LED indicator, however, does not light during this operation.

Determining Current Converter Settings

1. Determining the Number of Passes for Primary Conductors

- Determine the number of primary conductor passes and the setting tap according to the table. For example, for a current setting range of 2 to 5 A, the number of passes is four and the setting tap is 20.
- Pass the three wires through the holes from the same direction. It doesn't matter which wires go through which holes.

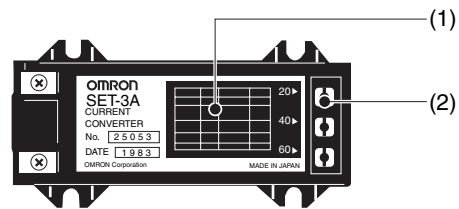
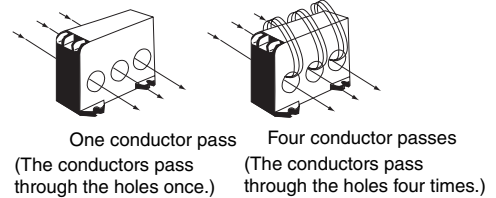

2. Setting the Tap

Use a screwdriver to screw the included setting screw into the required tap hole. After the setting has been made, be sure to mount the cover as it was before. The SET-3B does not have tap settings.

SAO-SU

Make the settings for the SAO-SU Current Sensor and the SET-3□ Current Converter according to the current of the load to be used.

Steady Current

Rated current (current setting range) (A)	Current scale multiplying factor label number	Current converter		
		Number of conductor passes	Setting tap	Model
1 to 2.5	0.25	8	20	SET-3A
2 to 5	0.5	4	20	
4 to 10	1	2	20	
8 to 20	2	1	20	
16 to 40	4	1	40	
32 to 80	8	1	80	
64 to 160	16	1	Fixed	SET-3B

Note: The current setting range is determined by the number of times the conductors to the SET-3□ are passed through and by the setting tap of the SET-3□. The current scale values are always 4 to 10 A. Therefore, attach the included current scale multiplying factor decal to the SAO that matches the current range.

Determining Current Sensor Settings

1. Determining the Current Scale Multiplying Factor

Determine a current scale multiplying factor that matches the steady current obtained from the table, and attach that decal to the Current Sensor. For example, when the current setting range is 2 to 5 A, the label number is 0.5.

2. Setting the Operating Current

Determine the operating current setting from the required steady current and the label number (i.e., multiplying factor), and make the setting using the current setting knob. The following table shows the relation between scale values and actual operating current values.

Setting Factor	4	5	6	7	8	9	10
× 0.25	1	1.25	1.5	1.75	2	2.25	2.5
× 0.5	2	2.5	3	3.5	4	4.5	5
× 1	4	5	6	7	8	9	10
× 2	8	10	12	14	16	18	20
× 4	16	20	24	28	32	36	40
× 8	32	40	48	56	64	72	80
× 16	64	80	96	112	128	144	160

These figures indicate steady current values. (Unit: A)

3. LED Operation Indicator

The indicator is continuously lit for normal current and not lit when undercurrent is detected.

4. Test Button

Pressing the test button momentarily operates the output relay.

Determining Current Converter Settings

1. Determining the Number of Passes for Primary Conductors

- Determine the number of primary conductor passes and the setting tap according to the table. For example, for a current setting range of 2 to 5 A, the number of passes is four and the setting tap is 20.
- Pass the wires through the holes from the same direction. It doesn't matter which wires go through which holes.

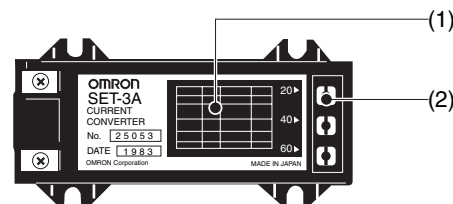
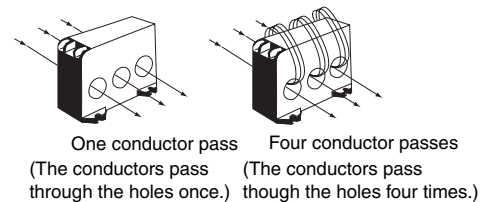

2. Setting the Tap

Use a screwdriver to screw the included setting screw into the required tap hole. After the setting has been made, be sure to mount the cover as it was before. The SET-3B does not have tap settings.

■ Checking Operation

The following circuit can be used to check SAO-□ and SET-3□ characteristics.

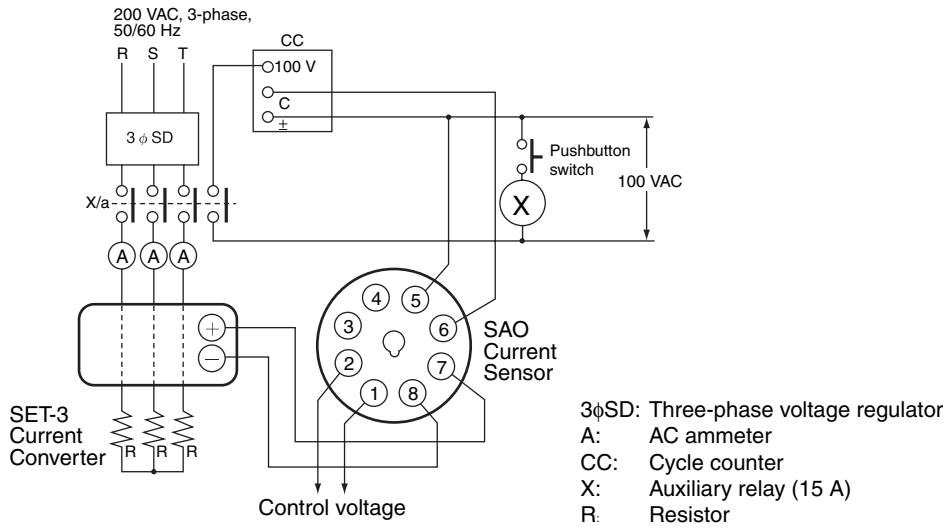

Dimensions

Note: All units are in millimeters unless otherwise indicated.

SAO-R/SAO-Q

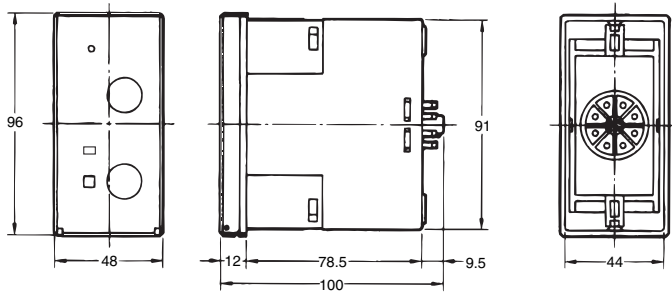
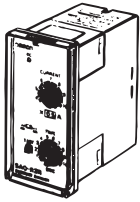

The Height of DIN Rail Mounting

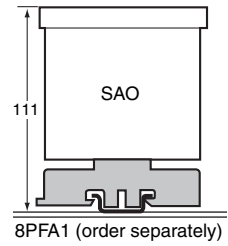

SAO-S/SAO-SU

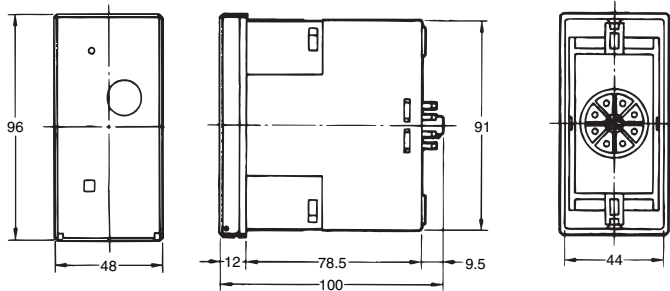
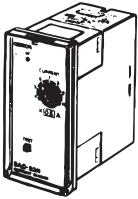

Current Converter SET-3A, SET-3B

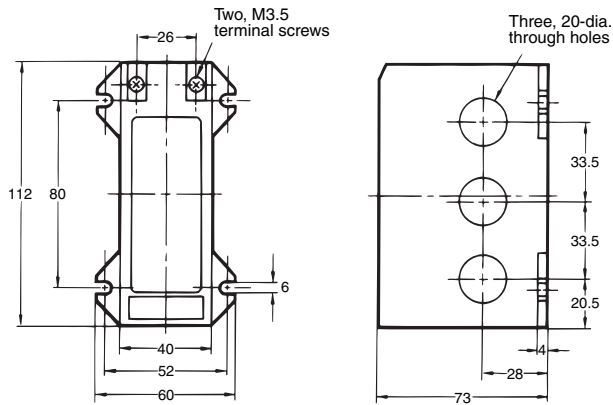
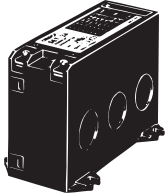

Mounting Holes

Four, 6-dia. mounting holes or four, M5 mounting screw holes

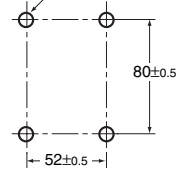

Precautions

On Operation

Use a commercial frequency power supply only for the control power supply.

The SET-3□ Current Converter is designed for use with a single SAO Current Sensor; do not connect two units to a single SET-3□ as in figure 1 below (even if a diode is included in the circuit).

If the current transformer has sufficient capacity, the circuit in figure 2 is acceptable.

Figure 1: Never Use this Setup

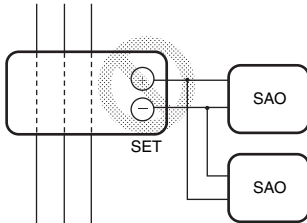
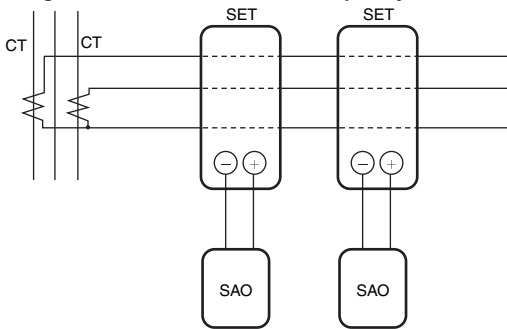

Figure 2: OK with Sufficient Capacity



Mounting

When installing with an 8PFA1 connecting socket, first fasten the socket firmly to the panel with screws, then plug in the relay and secure it with a hook. Leave at least 30 mm of space between the relays for the hooks.

Back-connecting sockets can not be used.

Connections

Make sure that the polarity is correct when connecting the Current Converter and Current Sensor. It is not necessary to consider polarity when using a DC control power supply.

Determine the necessary number of conductor runs from the table *Selecting the Current Converter* in the *Operation* section. Pass the wires through the holes from the same direction. It doesn't matter which wires go through which holes.

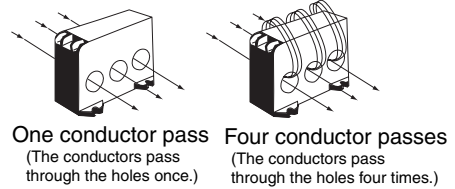

Testing Method

Verify operation by turning on the control voltage and pressing the test button.

It is possible to check whether SAO-□ and SET-3□ characteristics are correct or not with the test circuit shown on page 9.

Q&A

Q What is the procedure for using the SAO with a single phase?

A The following describes the single-phase operating procedure for the SAO. Models for single-phase circuits, however, are also available. Refer to SAO-□S.

Connection Procedure

Run the primary wires through any two of the three holes on the SET-3 the number of times specified for the SET-3□.

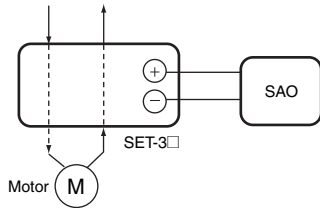

Setting Procedure

The operating value will change when single phase is used as in the figure above. Therefore, the setting must be changed.

Make the setting to approximately 0.77 times the current at which operation is desired. For example, for operation at 10 A, set the value to the following:

$$10 \times 0.77 = 7.7 \text{ A}$$

In any case, the SAO is adjusted for three-phase use. As a precautionary measure, therefore, perform confirmation testing using the actual load.

Q Can two SAO Current Sensors be used connected to one SET-3□? If not, can a diode or other device be inserted?

A It is not possible to connect two SAO Current Sensors to one SET-3□. The SET-3 output is designed so that the output voltage will match when one SAO (SE) is used. Operation is not possible even with a diode inserted. Operation as shown in figure 2, however, is possible if the capacity of the CT is sufficient.

Figure 1

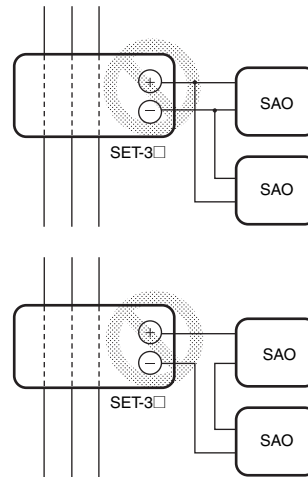
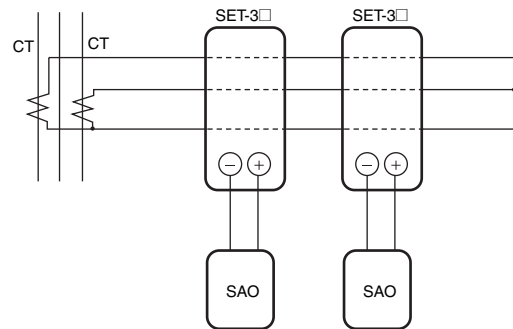

Figure 2



ALL DIMENSIONS SHOWN ARE IN MILLIMETERS.
To convert millimeters into inches, multiply by 0.03937. To convert grams into ounces, multiply by 0.03527.

In the interest of product improvement, specifications are subject to change without notice.

Read and Understand This Catalog

Please read and understand this catalog before purchasing the products. Please consult your OMRON representative if you have any questions or comments.

Warranty and Limitations of Liability

WARRANTY

OMRON's exclusive warranty is that the products are free from defects in materials and workmanship for a period of one year (or other period if specified) from date of sale by OMRON.

OMRON MAKES NO WARRANTY OR REPRESENTATION, EXPRESS OR IMPLIED, REGARDING NON-INFRINGEMENT, MERCHANTABILITY, OR FITNESS FOR PARTICULAR PURPOSE OF THE PRODUCTS. ANY BUYER OR USER ACKNOWLEDGES THAT THE BUYER OR USER ALONE HAS DETERMINED THAT THE PRODUCTS WILL SUITABLY MEET THE REQUIREMENTS OF THEIR INTENDED USE. OMRON DISCLAIMS ALL OTHER WARRANTIES, EXPRESS OR IMPLIED.

LIMITATIONS OF LIABILITY

OMRON SHALL NOT BE RESPONSIBLE FOR SPECIAL, INDIRECT, OR CONSEQUENTIAL DAMAGES, LOSS OF PROFITS OR COMMERCIAL LOSS IN ANY WAY CONNECTED WITH THE PRODUCTS, WHETHER SUCH CLAIM IS BASED ON CONTRACT, WARRANTY, NEGLIGENCE, OR STRICT LIABILITY.

In no event shall the responsibility of OMRON for any act exceed the individual price of the product on which liability is asserted.

IN NO EVENT SHALL OMRON BE RESPONSIBLE FOR WARRANTY, REPAIR, OR OTHER CLAIMS REGARDING THE PRODUCTS UNLESS OMRON'S ANALYSIS CONFIRMS THAT THE PRODUCTS WERE PROPERLY HANDLED, STORED, INSTALLED, AND MAINTAINED AND NOT SUBJECT TO CONTAMINATION, ABUSE, MISUSE, OR INAPPROPRIATE MODIFICATION OR REPAIR.

Application Considerations

SUITABILITY FOR USE

OMRON shall not be responsible for conformity with any standards, codes, or regulations that apply to the combination of products in the customer's application or use of the products.

At the customer's request, OMRON will provide applicable third party certification documents identifying ratings and limitations of use that apply to the products. This information by itself is not sufficient for a complete determination of the suitability of the products in combination with the end product, machine, system, or other application or use.

The following are some examples of applications for which particular attention must be given. This is not intended to be an exhaustive list of all possible uses of the products, nor is it intended to imply that the uses listed may be suitable for the products:

- Outdoor use, uses involving potential chemical contamination or electrical interference, or conditions or uses not described in this catalog.
- Nuclear energy control systems, combustion systems, railroad systems, aviation systems, medical equipment, amusement machines, vehicles, safety equipment, and installations subject to separate industry or government regulations.
- Systems, machines, and equipment that could present a risk to life or property.

Please know and observe all prohibitions of use applicable to the products.

NEVER USE THE PRODUCTS FOR AN APPLICATION INVOLVING SERIOUS RISK TO LIFE OR PROPERTY WITHOUT ENSURING THAT THE SYSTEM AS A WHOLE HAS BEEN DESIGNED TO ADDRESS THE RISKS, AND THAT THE OMRON PRODUCTS ARE PROPERLY RATED AND INSTALLED FOR THE INTENDED USE WITHIN THE OVERALL EQUIPMENT OR SYSTEM.

PROGRAMMABLE PRODUCTS

OMRON shall not be responsible for the user's programming of a programmable product, or any consequence thereof.

Disclaimers

CHANGE IN SPECIFICATIONS

Product specifications and accessories may be changed at any time based on improvements and other reasons.

It is our practice to change model numbers when published ratings or features are changed, or when significant construction changes are made. However, some specifications of the products may be changed without any notice. When in doubt, special model numbers may be assigned to fix or establish key specifications for your application on your request. Please consult with your OMRON representative at any time to confirm actual specifications of purchased products.

DIMENSIONS AND WEIGHTS

Dimensions and weights are nominal and are not to be used for manufacturing purposes, even when tolerances are shown.

PERFORMANCE DATA

Performance data given in this catalog is provided as a guide for the user in determining suitability and does not constitute a warranty. It may represent the result of OMRON's test conditions, and the users must correlate it to actual application requirements. Actual performance is subject to the OMRON Warranty and Limitations of Liability.

ERRORS AND OMISSIONS

The information in this document has been carefully checked and is believed to be accurate; however, no responsibility is assumed for clerical, typographical, or proofreading errors, or omissions.

2011.12

In the interest of product improvement, specifications are subject to change without notice.

OMRON Corporation
Industrial Automation Company

<http://www.ia.omron.com/>

(c)Copyright OMRON Corporation 2011 All Right Reserved.

Mouser Electronics

Authorized Distributor

Click to View Pricing, Inventory, Delivery & Lifecycle Information:

[Omron:](#)

[SET-3A](#) [SET-3B](#)



Компания «ЭлектроПласт» предлагает заключение долгосрочных отношений при поставках импортных электронных компонентов на взаимовыгодных условиях!

Наши преимущества:

- Оперативные поставки широкого спектра электронных компонентов отечественного и импортного производства напрямую от производителей и с крупнейших мировых складов;
- Поставка более 17-ти миллионов наименований электронных компонентов;
- Поставка сложных, дефицитных, либо снятых с производства позиций;
- Оперативные сроки поставки под заказ (от 5 рабочих дней);
- Экспресс доставка в любую точку России;
- Техническая поддержка проекта, помощь в подборе аналогов, поставка прототипов;
- Система менеджмента качества сертифицирована по Международному стандарту ISO 9001;
- Лицензия ФСБ на осуществление работ с использованием сведений, составляющих государственную тайну;
- Поставка специализированных компонентов (Xilinx, Altera, Analog Devices, Intersil, Interpoint, Microsemi, Aeroflex, Peregrine, Syfer, Eurofarad, Texas Instrument, Miteq, Cobham, E2V, MA-COM, Hittite, Mini-Circuits, General Dynamics и др.);

Помимо этого, одним из направлений компании «ЭлектроПласт» является направление «Источники питания». Мы предлагаем Вам помощь Конструкторского отдела:

- Подбор оптимального решения, техническое обоснование при выборе компонента;
- Подбор аналогов;
- Консультации по применению компонента;
- Поставка образцов и прототипов;
- Техническая поддержка проекта;
- Защита от снятия компонента с производства.



Как с нами связаться

Телефон: 8 (812) 309 58 32 (многоканальный)

Факс: 8 (812) 320-02-42

Электронная почта: org@eplast1.ru

Адрес: 198099, г. Санкт-Петербург, ул. Калинина, дом 2, корпус 4, литера А.