

Brief Description

The ZSPM4141 is an ultra-low-power linear regulator optimized for minimal quiescent current losses via advanced, proprietary technology. It can improve energy efficiency and reduce heat due to power dissipation because it draws low nA-level quiescent current for light loads, yet it can regulate current loads as high as 200mA. The linear regulated output voltage is factory-configured to an option from 1.2V to 4.2V in 100mV steps. The ZSPM4141 also provides over-current protection.

Features

- Low operating voltage range: 2.5V to 5.5V
- Power-Down Mode for 100pA quiescent current
- Over-current protection: 250mA
- Output voltage options of 1.2V to 4.2V in 100mV steps (programmed at manufacturing)

Benefits

- Ultra-low 100pA quiescent current in power down mode
- Best-in-class quiescent current of 20nA at $I_{LOAD}=0$
- 0.5% DC line regulation (typical)
- Extends battery life
- Enables power harvesting applications
- High level of integration minimizes board space

Related IDT Smart Power Products

- ZSPM4121 Under-Voltage Load Switch for Smart Battery Management

Available Support

- ZSPM4141W12KIT Evaluation Kit
- Support Documentation

Physical Characteristics

- Package: 8-pin DFN (2mm x2mm)

Typical ZSPM4141 Application Circuits

ZSPM4141 Basic (Fixed Output) Application

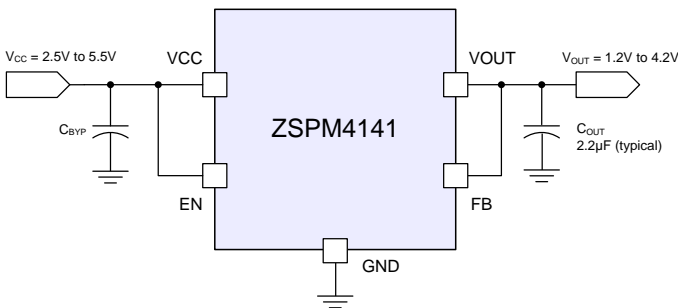

ZSPM4141A1W12 Variable VOUT via Resistor Divider

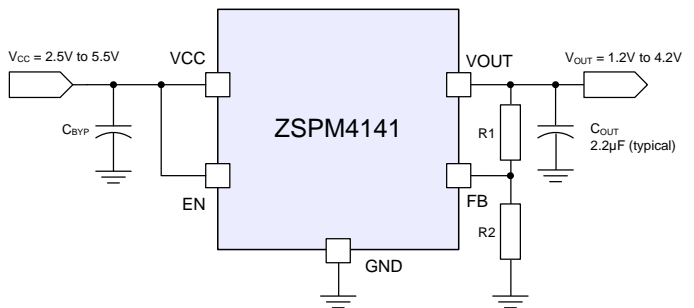

ZSPM4141 Block Diagram

- Typical Applications**
- Portable Electronics
 - Industrial
 - Medical
 - Smart Cards
 - RFID
 - Energy-Harvesting Systems

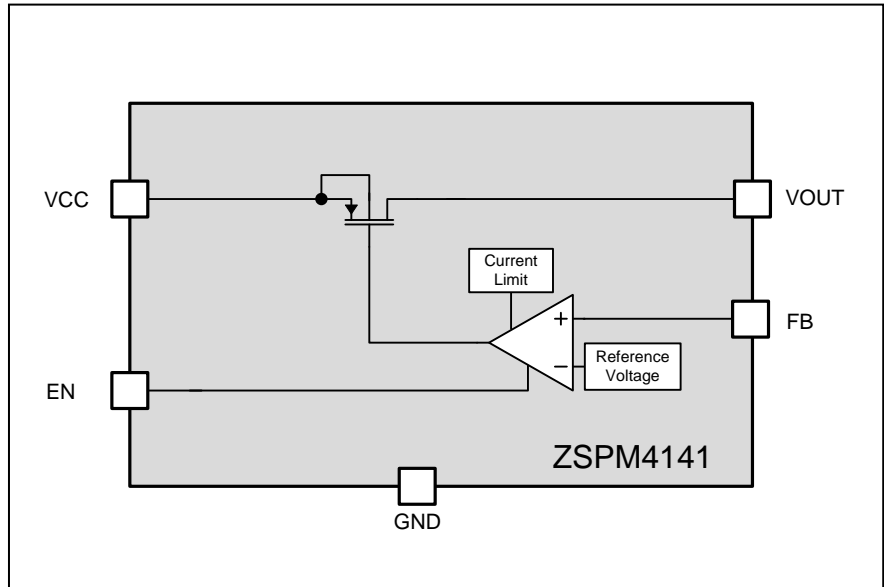

Ordering Information

Ordering Code*	Description	Package
ZSPM4141A1W12	ZSPM4141 Ultra-Low Power Line Regulator — V_{OUT} factory set to 1.2V	8-pin DFN / Reel
ZSPM4141A1W18	ZSPM4141 Ultra-Low Power Line Regulator — V_{OUT} factory set to 1.8V	8-pin DFN / Reel
ZSPM4141A1W25	ZSPM4141 Ultra-Low Power Line Regulator — V_{OUT} factory set to 2.5V	8-pin DFN / Reel
ZSPM4141A1W30	ZSPM4141 Ultra-Low Power Line Regulator — V_{OUT} factory set to 3.0V	8-pin DFN / Reel
ZSPM4141A1W31	ZSPM4141 Ultra-Low Power Line Regulator — V_{OUT} factory set to 3.1V	8-pin DFN / Reel
ZSPM4141A1W33	ZSPM4141 Ultra-Low Power Line Regulator — V_{OUT} factory set to 3.3V	8-pin DFN / Reel
ZSPM4141A1W42	ZSPM4141 Ultra-Low Power Line Regulator — V_{OUT} factory set to 4.2V	8-pin DFN / Reel
ZSPM4141W12KIT	ZSPM4141 Evaluation Kit w/Vout adjusting resistors (default 1.2 Vout)	

* W for 7" reel with 2500 parts. Custom V_{OUT} values are also available: 1.2V to 4.2V (typical) in 100mV increments.



Corporate Headquarters
6024 Silver Creek Valley Road
San Jose, CA 95138
www.IDT.com

Sales
1-800-345-7015 or 408-284-8200
Fax: 408-284-2775
www.IDT.com/go/sales

Tech Support
www.IDT.com/go/support

DISCLAIMER Integrated Device Technology, Inc. (IDT) reserves the right to modify the products and/or specifications described herein at any time, without notice, at IDT's sole discretion. Performance specifications and operating parameters of the described products are determined in an independent state and are not guaranteed to perform the same way when installed in customer products. The information contained herein is provided without representation or warranty of any kind, whether express or implied, including, but not limited to, the suitability of IDT's products for any particular purpose, an implied warranty of merchantability, or non-infringement of the intellectual property rights of others. This document is presented only as a guide and does not convey any license under intellectual property rights of IDT or any third parties.

IDT's products are not intended for use in applications involving extreme environmental conditions or in life support systems or similar devices where the failure or malfunction of an IDT product can be reasonably expected to significantly affect the health or safety of users. Anyone using an IDT product in such a manner does so at their own risk, absent an express, written agreement by IDT.

Integrated Device Technology, IDT and the IDT logo are trademarks or registered trademarks of IDT and its subsidiaries in the United States and other countries. Other trademarks used herein are the property of IDT or their respective third party owners. For datasheet type definitions and a glossary of common terms, visit www.idt.com/go/glossary. All contents of this document are copyright of Integrated Device Technology, Inc. All rights reserved.

Contents

1	ZSPM4141 Characteristics.....	5
1.1.	Absolute Maximum Ratings.....	5
1.2.	Thermal Characteristics.....	5
1.3.	Recommended Operating Conditions	6
1.4.	Electrical Characteristics	6
2	Typical Performance Characteristics	7
3	Description of Circuit	9
4	Application Circuits.....	10
4.1.	Selection of External Components	10
4.1.1.	Output Bypass Capacitor C_{OUT}	10
4.1.2.	Input Bypass Capacitor C_{BYP}	10
4.1.3.	Output Voltage Adjustment Resistors R1 and R2.....	10
4.2.	Typical Application Circuit	11
5	Pin Configuration and Package.....	12
5.1.	ZSPM4141 Package Dimensions and Marking Diagram	12
5.2.	Pin Assignments.....	13
6	Layout and Soldering Requirements.....	14
6.1.	Recommended Landing Pattern for PCBs	14
6.2.	Multi-Layer PCB Layout.....	15
6.3.	Single-Layer PCB Layout	16
7	Ordering Information	17
8	Related Documents.....	17
9	Document Revision History	18

List of Figures

Figure 2.1	I_{QQ} Performance vs. V_{CC}	7
Figure 2.2	I_{QQ} Performance vs. Temperature	7
Figure 2.3	I_{QQ} Performance vs. Load Current.....	7
Figure 2.4	I_{QQ} Performance vs. Load Current in %.....	7
Figure 2.5	Line Regulation Performance	7
Figure 2.6	V_{OUT} Performance vs. Temperature.....	7
Figure 2.7	Dropout Voltage When V_{OUT} Drops By 3%.....	8
Figure 2.8	Load Regulation Performance	8
Figure 2.9	Load Step Response— $I_{OUT} = 0$ to 30mA	8
Figure 2.10	Load Step Response— $I_{OUT} = 30$ mA to 0	8
Figure 2.11	Load Step Response— $I_{OUT} = 1$ mA to 30mA.....	8
Figure 2.12	Line Step Response	8

Figure 2.13	Output Enable Timing	9
Figure 3.1	ZSPM4141 Block Diagram	9
Figure 4.1	Basic ZSPM4141 Application Circuit—Fixed Output.....	11
Figure 4.2	ZSPM4141A1W12 Application Circuit—Variable Output	11
Figure 5.1	ZSPM4141 Package Drawing.....	12
Figure 5.2	ZSPM4141 Pin Assignments (top view)	13
Figure 6.1	Recommended Landing Pattern for 8-Pin DFN.....	14
Figure 6.2	Package and PCB Land Configuration for Multi-Layer PCB	15
Figure 6.3	JEDEC Standard FR4 Multi-Layer Board – Cross-Sectional View.....	15
Figure 6.4	Conducting Heat Away from the Die using an Exposed Pad Package	16
Figure 6.5	Application Using a Single-Layer PCB	16

List of Tables

Table 1.1	Absolute Maximum Ratings	5
Table 1.2	Thermal Characteristics for 8-pin DFN (2x2) Package.....	5
Table 1.3	Recommended Operating Conditions	6
Table 1.4	Electrical Characteristics	6
Table 4.1	Output Voltage Adjustment Resistors and Resulting I_{QQ} Increase	10
Table 5.1	Pin Description, 8-Pin DFN (2mmx2mm)	13

1 ZSPM4141 Characteristics

Important: Stresses beyond those listed under “Absolute Maximum Ratings” (section 1.1) may cause permanent damage to the device. These are stress ratings only. Functional operation of the device at these or any other conditions beyond those indicated under “Recommended Operating Conditions” (section 1.3) is not implied. Exposure to absolute–maximum–rated conditions for extended periods could affect device reliability.

1.1. Absolute Maximum Ratings

Over operating free–air temperature range unless otherwise noted. All voltage values are with respect to network ground terminal.

Table 1.1 Absolute Maximum Ratings

Parameter	Symbol	Value	Unit
Maximum input/output on VCC, VOUT, EN, and FB pins		-0.3 to 6.0	V
Electrostatic Discharge – Human Body Model, according to the respective JESD22 JEDEC standard		2	kV
Electrostatic Discharge – Charged Device Model, according to the respective JESD22-C101 JEDEC standard		500	V
Operating Junction Temperature Range	T_J	-20 to 85	°C
Storage Temperature Range	T_{stg}	-65 to 150	°C
Lead Temperature (soldering, 10 seconds)		260	°C

1.2. Thermal Characteristics

Table 1.2 Thermal Characteristics for 8-pin DFN (2x2) Package

θ_{JA} (°C/W) ¹⁾	θ_{JC} (°C/W) ²⁾
73.1	10.7
1) This assumes a FR4 board only. 2) This assumes a 1oz. copper JEDEC standard board with thermal vias. See section 6.1 for more information.	

1.3. Recommended Operating Conditions

Table 1.3 Recommended Operating Conditions

Parameter	Symbol	Min	Typ	Max	Unit
Unregulated Supply Input at VCC pin	V _{CC}	2.5		5.5	V
Enable Input (EN pin)	V _{EN}	0		5.0	V
Typical Regulated Supply Output Voltage	V _{OUT}	1.2		4.2	V
Operating Ambient Temperature ¹⁾	T _A	-20		55	°C
Operating Junction Temperature	T _J	-20		85	°C
1) Operating ambient temperature is only intended as a guideline. The operating junction temperature requirements must not be exceeded.					

1.4. Electrical Characteristics

Electrical characteristics, V_{CC} = 2.5V to 5V (unless otherwise noted). Minimum and maximum characteristics tested at T_J = 25°C.

Table 1.4 Electrical Characteristics

Parameter	Symbol	Condition	Min	Typ	Max	Unit
Input Supply Voltage	V _{CC}		2.5		5.5	V
Input Low Logic Level	V _{IL} EN				0.3*V _{CC}	V
Input High Logic Level	V _{IH} EN		0.7*V _{CC}			V
Output Bypass Capacitor	C _{OUT}		1	2.2	4.7	μF
Input Bypass Capacitor	C _{BYP}			0.1		μF
Quiescent Current:	I _{QQ}	V _{CC} = 4.2V, I _{OUT} =0		20		nA
Quiescent Current: Power-Down Mode	I _{QQpd}	I _{OUT} =0, EN = 0		100		pA
Operating Current	I _{OP-GND}	V _{CC} = 2.5V, I _{OUT} = 200mA		200		μA
		V _{CC} = 3.3V, I _{OUT} = 200mA		200		μA
		V _{CC} = 5.5V, I _{OUT} = 200mA		200		μA
Load Capability	I _{OUT}		0		200	mA
DC Line Regulation	V _{LINE}	V _{CC} = 2.5V to 5V, V _{OUT} =1.8V, I _{OUT} = 50mA		0.5	1	%
DC Load Regulation	V _{LOAD}	V _{CC} = 4.2V, I _{OUT} = 0.02mA to 200mA, V _{OUT} = V _{OUT,nominal} +300mV		1	2	%
Current Limit	I _{LIMIT}	I _{OUT} measured at V _{OUT} = 0.9*V _{OUT,nominal}		250		mA

2 Typical Performance Characteristics

$C_{IN} = 10\mu F$ and $T = 25^\circ C$ (unless otherwise noted)

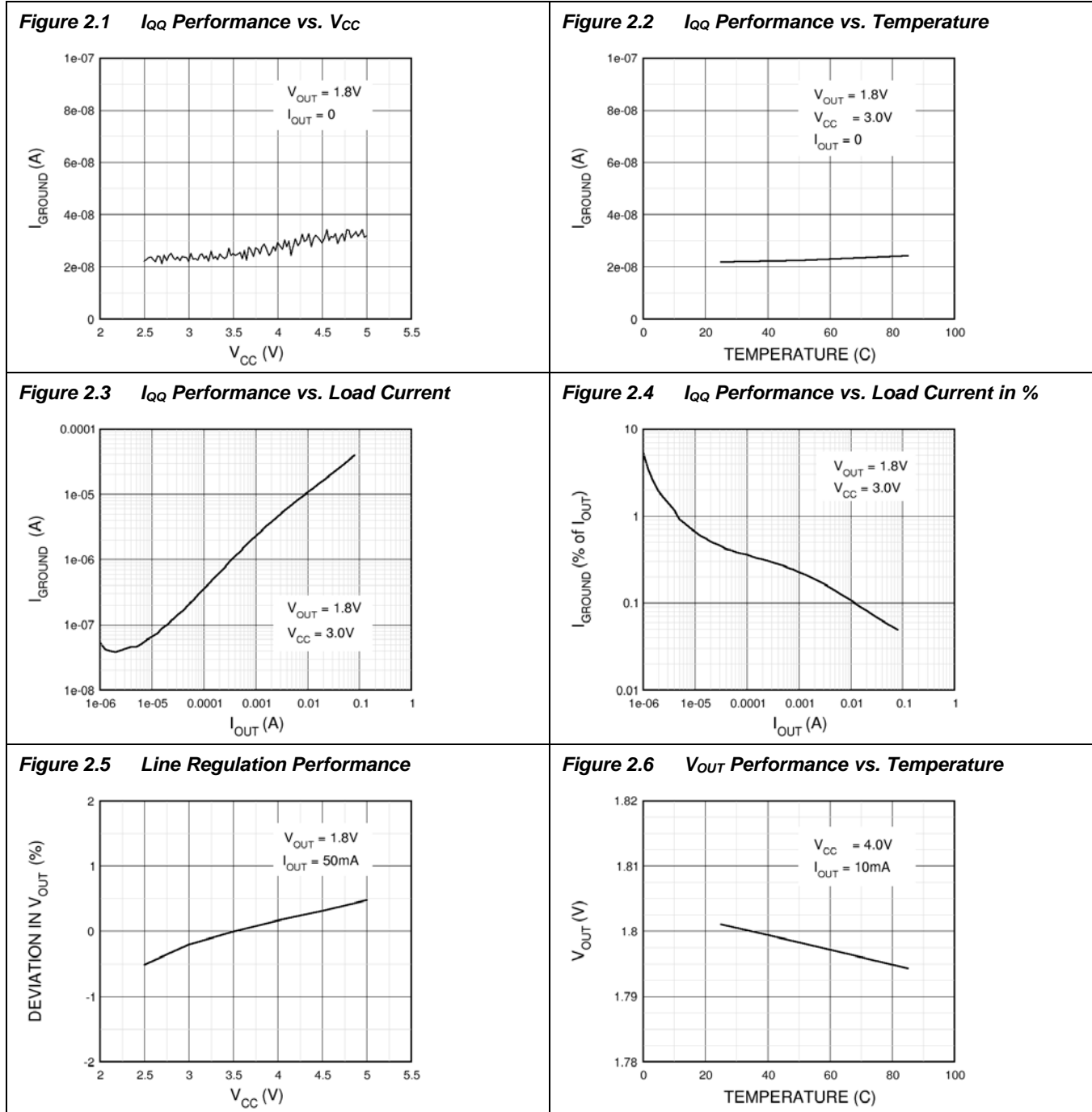
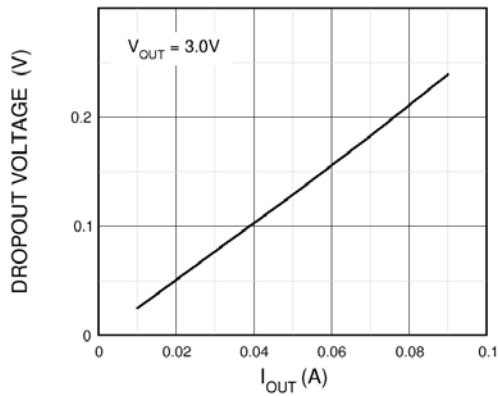

Figure 2.7 Dropout Voltage When V_{OUT} Drops By 3%



Note: Dropout voltage is defined as $V_{CC} - V_{OUT}$ when V_{OUT} drops 3% below its nominal value.

Figure 2.8 Load Regulation Performance

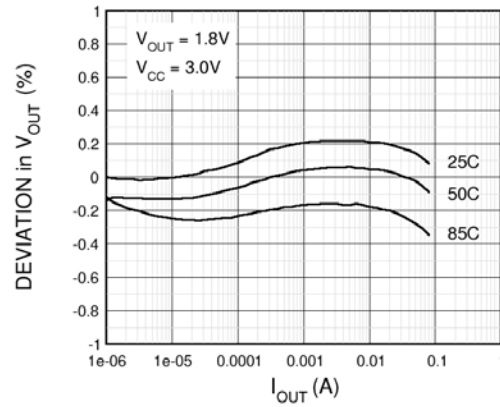

Figure 2.9 Load Step Response— $I_{OUT} = 0$ to 30mA

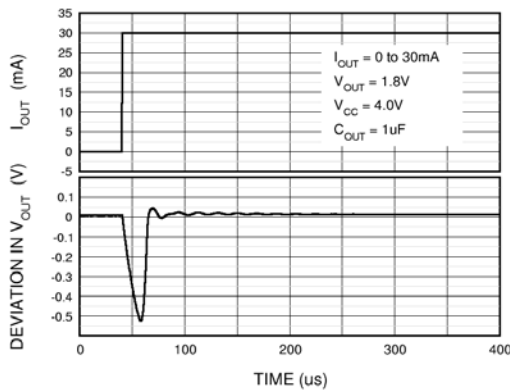

Figure 2.10 Load Step Response— $I_{OUT} = 30mA$ to 0

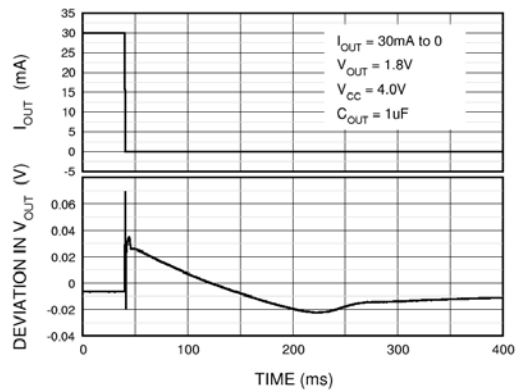

Figure 2.11 Load Step Response— $I_{OUT} = 1mA$ to 30mA

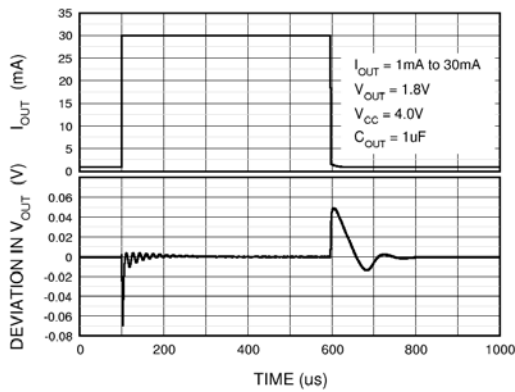
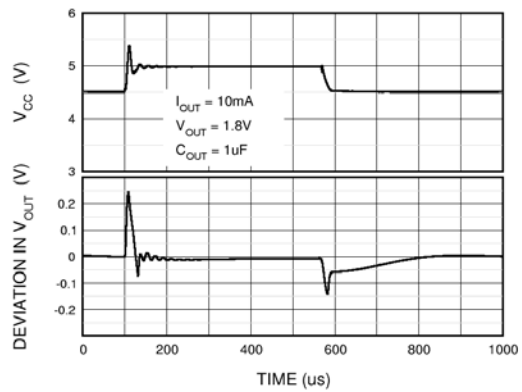
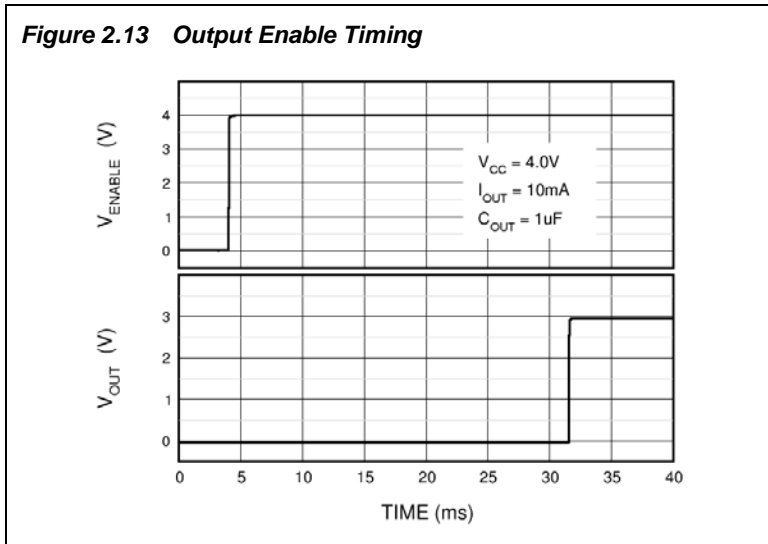

Figure 2.12 Line Step Response





3 Description of Circuit

The ZSPM4141 is an ultra-low-power linear regulator optimized for minimal quiescent current losses via advanced, proprietary technology. It draws low nA-level quiescent current for light loads, yet it can regulate current loads as high as 200mA. The linear regulated output voltage is factory-configured to an option from 1.2V to 4.2V in 100mV steps. The ZSPM4141 also provides over-current protection (see Table 1.4).

Figure 3.1 ZSPM4141 Block Diagram

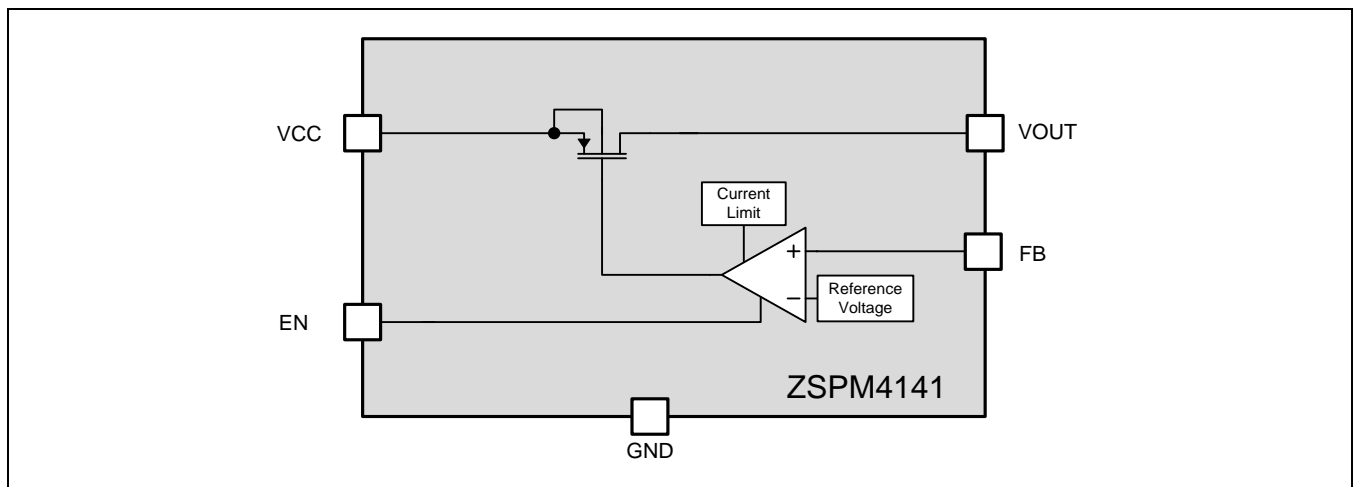

4 Application Circuits

4.1 Selection of External Components

4.1.1 Output Bypass Capacitor C_{OUT}

Connect a bypass capacitor (C_{OUT}) from the VOUT pin to ground. The typical value for C_{OUT} is 2.2 μ F.

See Table 1.4 for further specifications.

4.1.2 Input Bypass Capacitor C_{BYP}

Connect a bypass capacitor (C_{BYP}) from the VCC pin to ground. The typical value for C_{OUT} is 0.1 μ F.

4.1.3 Output Voltage Adjustment Resistors R1 and R2

The ZSPM4141W12KIT includes a set of output adjustment resistors for R1 and R2 shown in the variable output circuit on page 2. Refer to Table 4.1 for the effect of different combinations of the resistors on the output voltage and the resulting increase in I_{QQ} current.

Table 4.1 Output Voltage Adjustment Resistors and Resulting I_{QQ} Increase

Vout	R1 (+/-0.1%)	R2 (+/-1%)	I_{QQ} increase
1.2	0		
1.5	1.00M Ω	4.02M Ω	0.30 μ A
1.8	1.00M Ω	2M Ω	0.60 μ A
3	1.00M Ω	665k Ω	1.80 μ A
3.3	1.00M Ω	576k Ω	2.10 μ A
4.2	1.00M Ω	402k Ω	3.00 μ A

4.2. Typical Application Circuit

Figure 4.1 Basic ZSPM4141 Application Circuit—Fixed Output

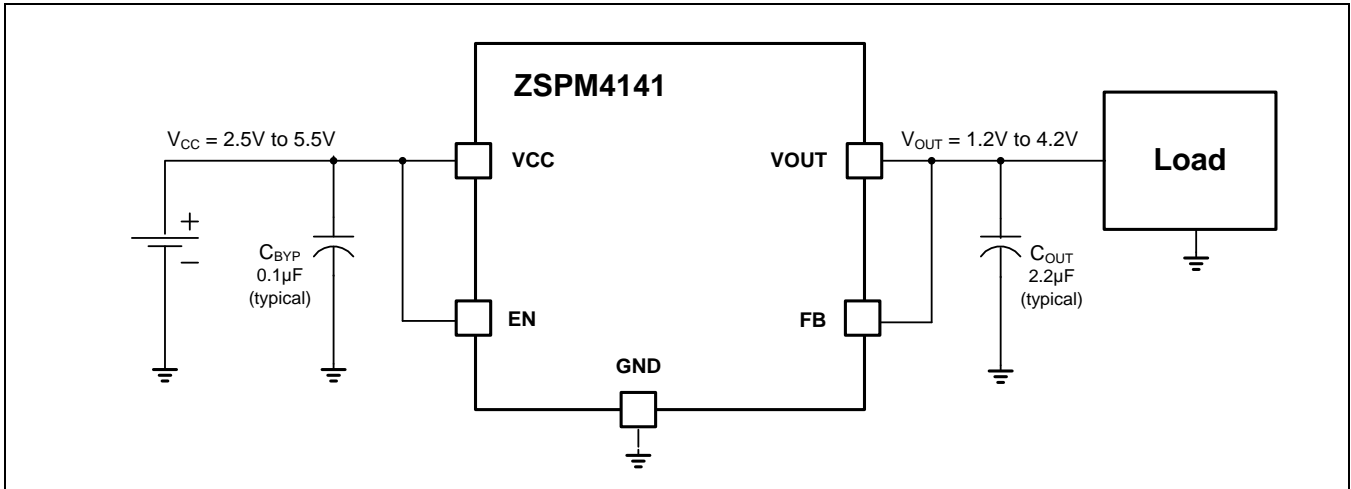
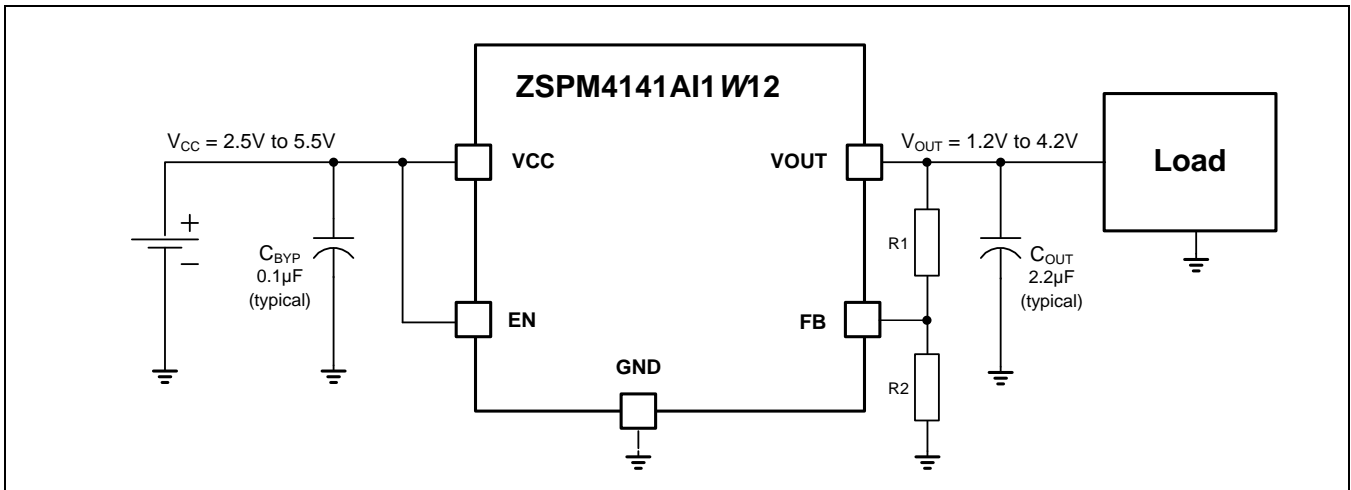

Figure 4.2 ZSPM4141A1W12 Application Circuit—Variable Output



5 Pin Configuration and Package

5.1. ZSPM4141 Package Dimensions and Marking Diagram

Figure 5.1 ZSPM4141 Package Drawing

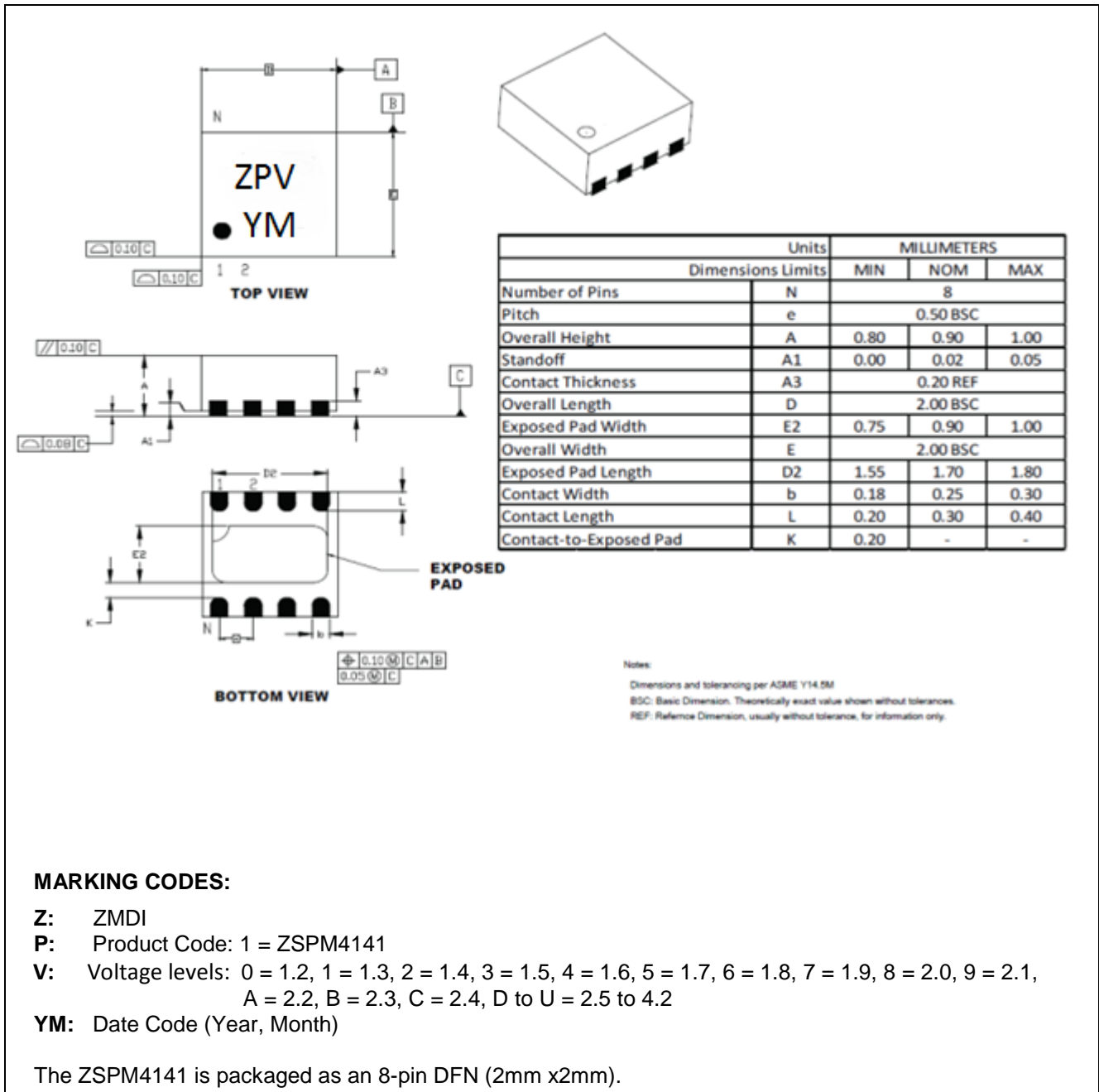

5.2. Pin Assignments

Figure 5.2 ZSPM4141 Pin Assignments (top view)

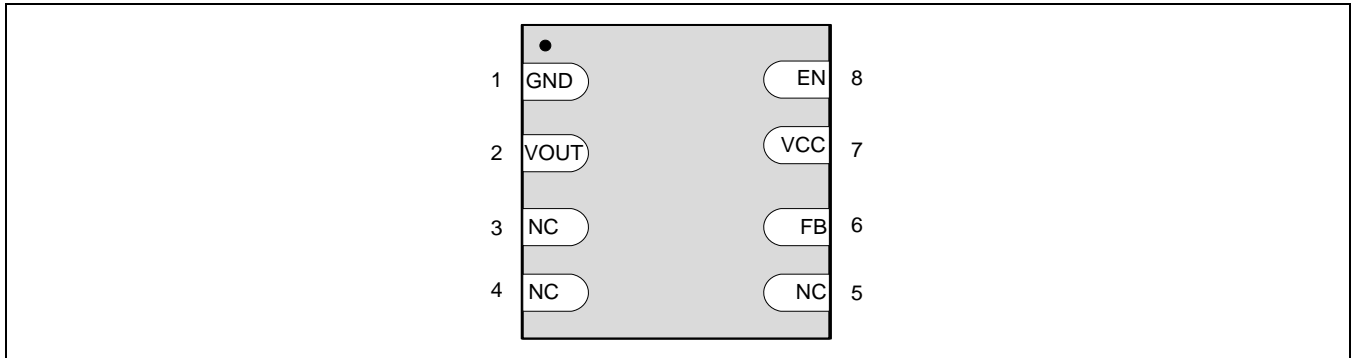

Table 5.1 Pin Description, 8-Pin DFN (2mmx2mm)

Pin #	Name	Function	Description
1	GND	Ground	GND
2	VOUT	Output	Regulated Output Voltage
3	NC		No Connection (connect to GND or float)
4	NC		No Connection (connect to GND or float)
5	NC		No Connection (connect to GND or float)
6	FB	Input	Feedback Input
7	VCC	Supply	Input Power
8	EN	Input	Enable Input

6 Layout and Soldering Requirements

To maximize the efficiency of this package for applications on a single layer or multi-layer printed circuit board (PCB), certain guidelines must be followed when laying out this part on the PCB.

6.1. Recommended Landing Pattern for PCBs

Figure 6.1 Recommended Landing Pattern for 8-Pin DFN

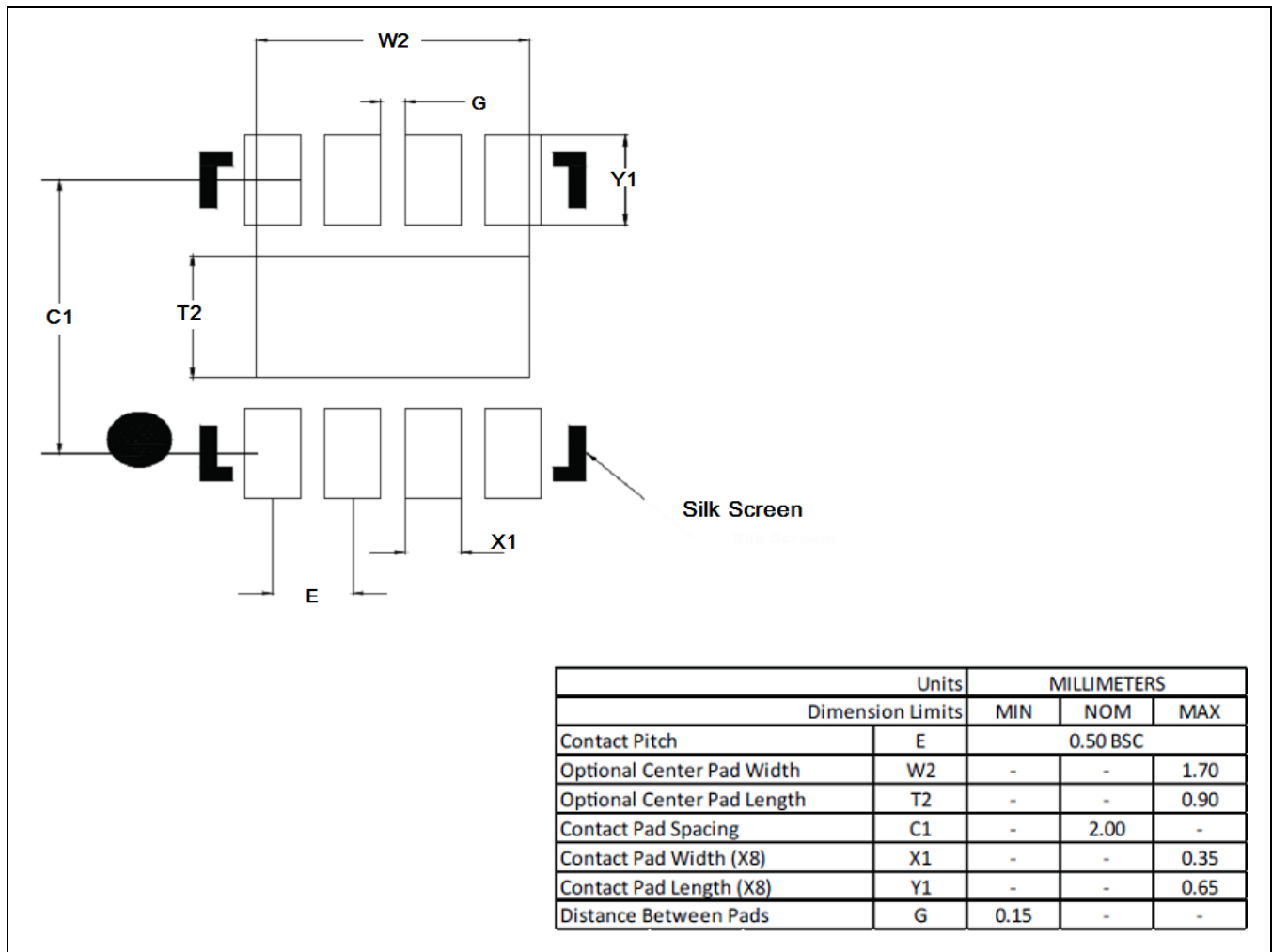

6.2. Multi-Layer PCB Layout

The following are guidelines for mounting the exposed pad ZSPM4141 on a multi-layer PCB with ground a plane. In a multi-layer board application, the thermal vias are the primary method of heat transfer from the package thermal pad to the internal ground plane. The efficiency of this method depends on several factors, including die area, number of thermal vias, and thickness of copper, etc.

Figure 6.2 Package and PCB Land Configuration for Multi-Layer PCB

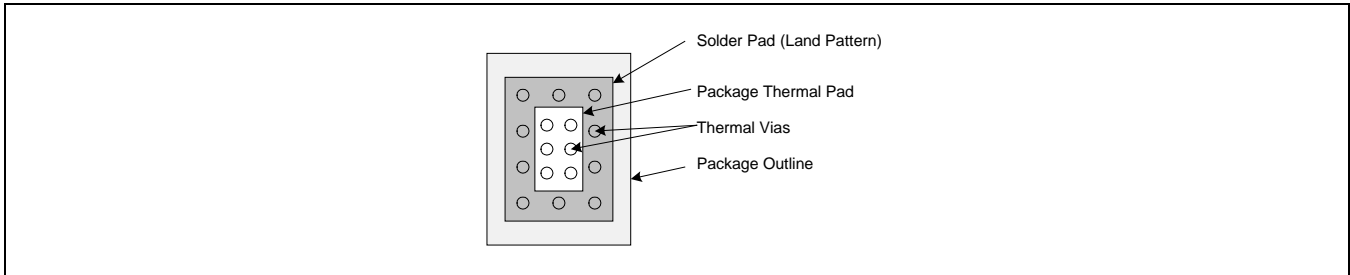

Figure 6.3 JEDEC Standard FR4 Multi-Layer Board – Cross-Sectional View

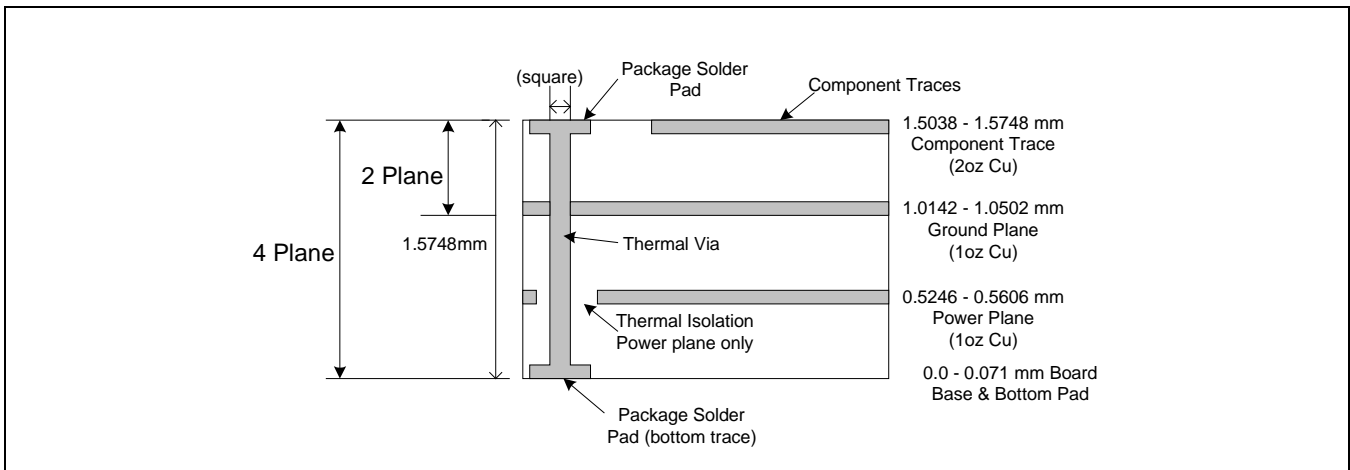
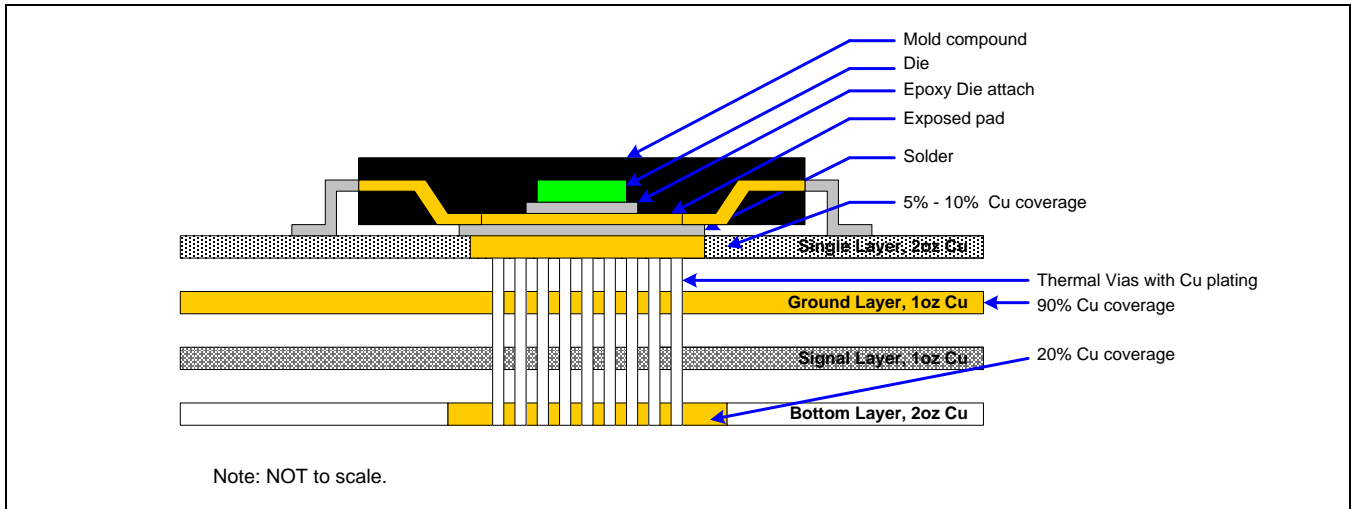

Figure 6.4 is a representation of how the heat can be conducted away from the die using an exposed pad package. Each application will have different requirements and limitations, and therefore the user should use sufficient copper to dissipate the power in the system. The output current rating for the linear regulators might need to be de-rated for ambient temperatures above 85°C. The de-rated value will depend on calculated worst-case power dissipation and the thermal management implementation in the application.

Figure 6.4 Conducting Heat Away from the Die using an Exposed Pad Package



6.3. Single-Layer PCB Layout

Layout recommendation for a single-layer PCB: utilize as much copper area for power management as possible. In a single-layer board application, the thermal pad is attached to a heat spreader (copper areas) by using a low thermal impedance attachment method (solder paste or thermal conductive epoxy).

In both of the methods mentioned above, it is advisable to use as much copper trace as possible to dissipate the heat.

Figure 6.5 Application Using a Single-Layer PCB

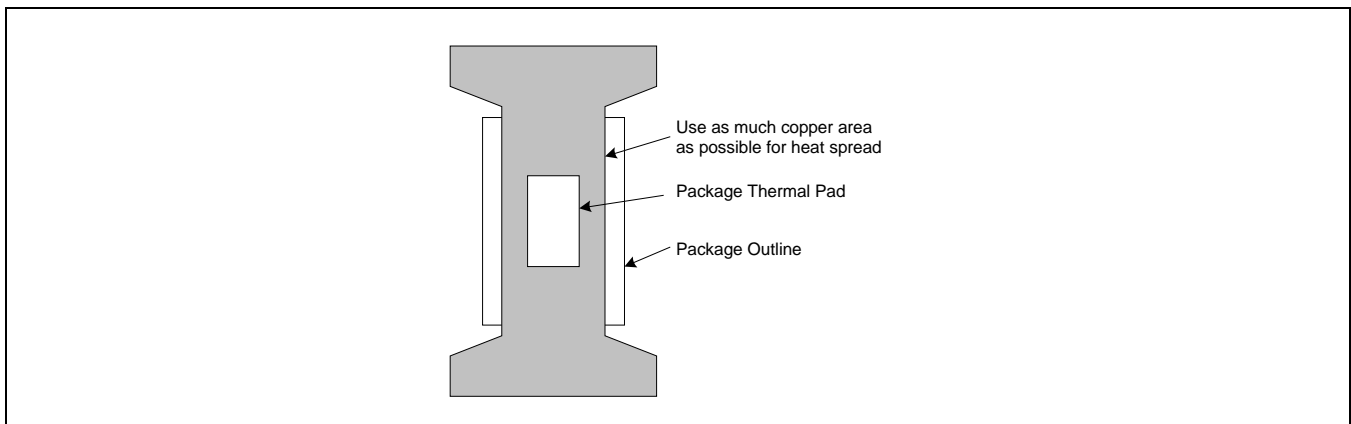

Important: If the attachment method is NOT implemented correctly, the functionality of the product is not guaranteed. Power dissipation capability will be adversely affected if the device is incorrectly mounted onto the circuit board.

7 Ordering Information

Ordering Code*	Description	Package
ZSPM4141AI1W12	ZSPM4141 Ultra-Low Power Line Regulator — V_{OUT} factory set to 1.2V	8-pin DFN / Reel
ZSPM4141AI1W18	ZSPM4141 Ultra-Low Power Line Regulator — V_{OUT} factory set to 1.8V	8-pin DFN / Reel
ZSPM4141AI1W25	ZSPM4141 Ultra-Low Power Line Regulator — V_{OUT} factory set to 2.5V	8-pin DFN / Reel
ZSPM4141AI1W30	ZSPM4141 Ultra-Low Power Line Regulator — V_{OUT} factory set to 3.0V	8-pin DFN / Reel
ZSPM4141AI1W31	ZSPM4141 Ultra-Low Power Line Regulator — V_{OUT} factory set to 3.1V	8-pin DFN / Reel
ZSPM4141AI1W33	ZSPM4141 Ultra-Low Power Line Regulator — V_{OUT} factory set to 3.3V	8-pin DFN / Reel
ZSPM4141AI1W42	ZSPM4141 Ultra-Low Power Line Regulator — V_{OUT} factory set to 4.2V	8-pin DFN / Reel
ZSPM4141W12KIT	ZSPM4141 Evaluation Kit w/ V_{out} adjusting resistors (default 1.2 Vout)	

Custom V_{OUT} values are also available: 1.2V to 4.2V (typical) in 100mV increments.

8 Related Documents

Document
<i>ZSPM4141 Feature Sheet</i>
<i>ZSPM4141 Evaluation Kit Description</i>
<i>ZSPM4141 Application Note—Low Power Battery Control and Voltage Regulator Solutions for Remote Sensor Networks</i>

Visit IDT's website www.IDT.com or contact your nearest sales office for the latest version of these documents.

9 Document Revision History

Revision	Date	Description
1.00	August 6, 2012	First release.
2.00	January 11, 2013	Addition of variable output illustration and Table 4.1. Update for ordering codes and contact information. Update for "Electrostatic Discharge" specification in Table 1.1.
	January 29, 2016	Changed to IDT branding.



Corporate Headquarters
 6024 Silver Creek Valley Road
 San Jose, CA 95138
www.IDT.com

Sales
 1-800-345-7015 or 408-284-8200
 Fax: 408-284-2775
www.IDT.com/go/sales

Tech Support
www.IDT.com/go/support

DISCLAIMER Integrated Device Technology, Inc. (IDT) reserves the right to modify the products and/or specifications described herein at any time, without notice, at IDT's sole discretion. Performance specifications and operating parameters of the described products are determined in an independent state and are not guaranteed to perform the same way when installed in customer products. The information contained herein is provided without representation or warranty of any kind, whether express or implied, including, but not limited to, the suitability of IDT's products for any particular purpose, an implied warranty of merchantability, or non-infringement of the intellectual property rights of others. This document is presented only as a guide and does not convey any license under intellectual property rights of IDT or any third parties.

IDT's products are not intended for use in applications involving extreme environmental conditions or in life support systems or similar devices where the failure or malfunction of an IDT product can be reasonably expected to significantly affect the health or safety of users. Anyone using an IDT product in such a manner does so at their own risk, absent an express, written agreement by IDT.

Integrated Device Technology, IDT and the IDT logo are trademarks or registered trademarks of IDT and its subsidiaries in the United States and other countries. Other trademarks used herein are the property of IDT or their respective third party owners. For datasheet type definitions and a glossary of common terms, visit www.idt.com/go/glossary. All contents of this document are copyright of Integrated Device Technology, Inc. All rights reserved.



Компания «ЭлектроПласт» предлагает заключение долгосрочных отношений при поставках импортных электронных компонентов на взаимовыгодных условиях!

Наши преимущества:

- Оперативные поставки широкого спектра электронных компонентов отечественного и импортного производства напрямую от производителей и с крупнейших мировых складов;
- Поставка более 17-ти миллионов наименований электронных компонентов;
- Поставка сложных, дефицитных, либо снятых с производства позиций;
- Оперативные сроки поставки под заказ (от 5 рабочих дней);
- Экспресс доставка в любую точку России;
- Техническая поддержка проекта, помощь в подборе аналогов, поставка прототипов;
- Система менеджмента качества сертифицирована по Международному стандарту ISO 9001;
- Лицензия ФСБ на осуществление работ с использованием сведений, составляющих государственную тайну;
- Поставка специализированных компонентов (Xilinx, Altera, Analog Devices, Intersil, Interpoint, Microsemi, Aeroflex, Peregrine, Syfer, Eurofarad, Texas Instrument, Miteq, Cobham, E2V, MA-COM, Hittite, Mini-Circuits, General Dynamics и др.);

Помимо этого, одним из направлений компании «ЭлектроПласт» является направление «Источники питания». Мы предлагаем Вам помощь Конструкторского отдела:

- Подбор оптимального решения, техническое обоснование при выборе компонента;
- Подбор аналогов;
- Консультации по применению компонента;
- Поставка образцов и прототипов;
- Техническая поддержка проекта;
- Защита от снятия компонента с производства.



Как с нами связаться

Телефон: 8 (812) 309 58 32 (многоканальный)

Факс: 8 (812) 320-02-42

Электронная почта: org@eplast1.ru

Адрес: 198099, г. Санкт-Петербург, ул. Калинина, дом 2, корпус 4, литера А.