



PRODUCT NUMBER
20020110-XXXXA01LF

20020110- [] [] [] [] A 0 1 L F

PITCH

C: 3.50 mm
D: 3.81 mm
G: 5.00 mm
H: 5.08 mm

POLES

02: 2 POLES
03: 3 POLES
04: 4 POLES

24: 24 POLES

HOUSING CODE

1: GREEN
2: BLACK

LF: DENOTED RoHS COMPATIBLE

PROPERTY TABLE

FCI SERIES NAME	06-350	06-381	06-500	06-508
PITCH (mm)	3.50	3.81	5.00	5.08
VOLTAGE RATING (VAC)	300	300	300	300
CURRENT RATING (A)	10	10	12	12
WITHSTANDING VOLTAGE (kV)	1.6	1.6	1.6	1.6
OPERATING TEMP. (°C)	-40~+115	-40~+115	-40~+115	-40~+115
SOLDERING TEMP. (°C)	250±10 (5 sec.)	250±10 (5 sec.)	250±10 (5 sec.)	250±10 (5 sec.)
POLES AVAILABLE	02~24	02~24	02~24	02~24
SAFETY CERTIFICATE				

NOTES:

- MATERIALS**
1-1 HOUSING: THERMALPLASTIC RESIN, UL 94V-0 RATED.
1-2 TERMINAL: COPPER, TIN PLATED.
- PRODUCT SPECIFICATION REFER TO FCI GS-12-625.**
- BOXED PACKAGING.**
DETAILED PRODUCT PACKING SPECIFICATION REFER TO FCI GS-14-1394.
- FCI, SAFETY CERTIFICATE LOGO AND SERIES NAME TO BE SHOWN ON PRODUCT SURFACE.**
- THE PRODUCTS WHERE THE PART NUMBER END IN "LF" MEET THE EUROPEAN UNION DIRECTIVE AND OTHER COUNTRY REGULATIONS AS DESCRIBED IN GS-22-008.
- RECOMENDED SOLDERING PROCESS BY WAVE SOLDER.

TOLERANCES UNLESS OTHERWISE SPECIFIED		rev	ecn no	dr	date
LINEAR	X.	±0.5	D	T10-0042	WL 030310
	X.X	±0.30	E	T10-0109	WL 070810
	X.XX	±0.10			
ANGULAR	X'	±1'			

Material	Spec ref	*	
Mat code	✓	tolerance	projection
Heattreat			MM
Plating/Finish			⊕
Dr BEER FU	062509		size A4
Eng BEER FU	062509	Product family	Scale
Chr GARY HSIEH	062509	Model Name	ECN T10-0109
Appr JOSEPH HSIA	062509	Model Revision	REL Level RELEASED
	title	TERMINAL BLOCK	dwg no 20020110
		Pluggable socket, right angle	Rev. E
Pro/E file	catalog no	CUSTOMER	sheet 1 of 5

FCI CONFIDENTIAL



This document is the property of and embodies CONFIDENTIAL and PROPRIETARY information of FCI. No part of the information shown on this document may be used in any way or disclosed to others without the written consent of FCI. Copyright FCI.

PRODUCT NUMBER	SERIES NAME	PITCH
20020110-CXXXA01LF	06-350	3.50 mm

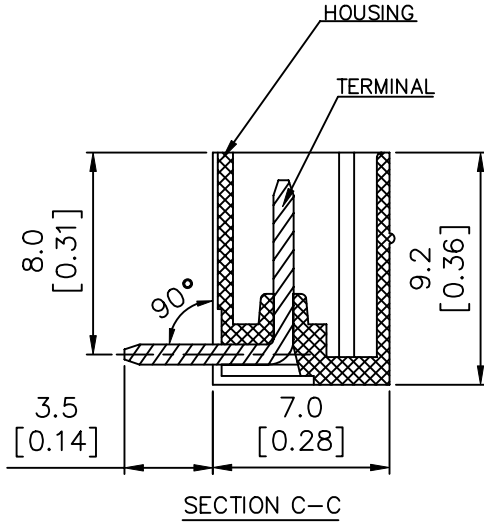
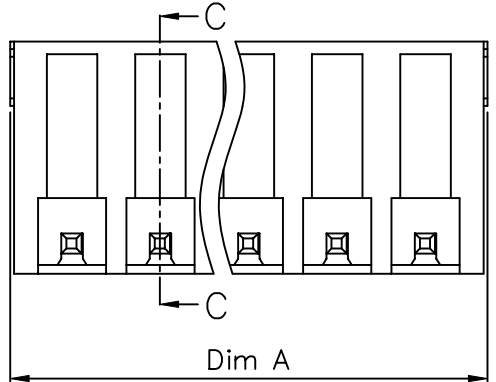
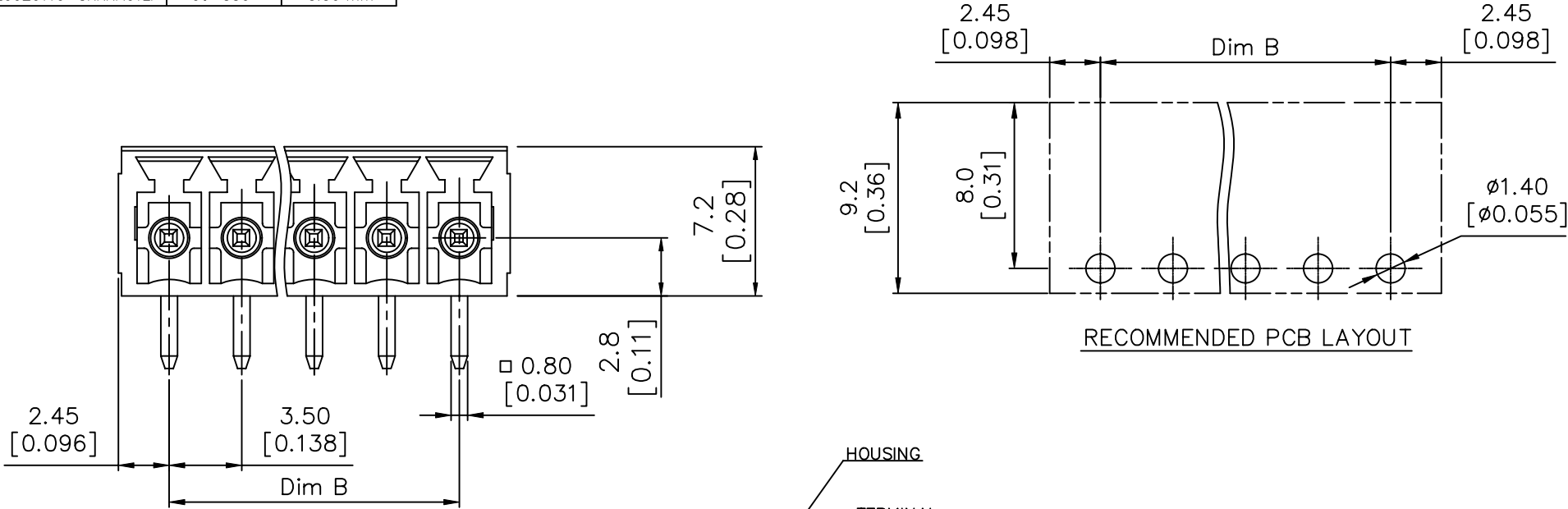

N = Number of poles
 Dim A = Dim B + 4.9 [0.193]
 Dim B = (N-1) x 3.5 [0.138]

TOL.	Dim A	Dim B
2-6p	±0.15 [0.006]	
7-12p	±0.20 [0.008]	
13-18p	±0.25 [0.010]	
19-24p	±0.30 [0.012]	

Material		Spec ref		
Mat code		✓	tolerance	projection
Heattreat				MM
Plating/Finish			⊕	←
Dr	BEER FU 062509		size	A4
Eng	BEER FU 062509	Product family		Scale
Chr	GARY HSIEH 062509	Model Name		ECN T10-0109
Appr	JOSEPH HSIA 062509	Model Revision		REL Level RELEASED
		title		dwg no
		TERMINAL BLOCK		20020110
		Pluggable socket, right angle		Rev. E
Pro/E file	catalog no	CUSTOMER		sheet 2 of 5

REV: 2008-04-17

FCI CONFIDENTIAL



This document is the property of and embodies CONFIDENTIAL and PROPRIETARY information of FCI. No part of the information shown on this document may be used in any way or disclosed to others without the written consent of FCI. Copyright FCI.

PRODUCT NUMBER	SERIES NAME	PITCH
20020110-DXXXA01LF	06-381	3.81 mm

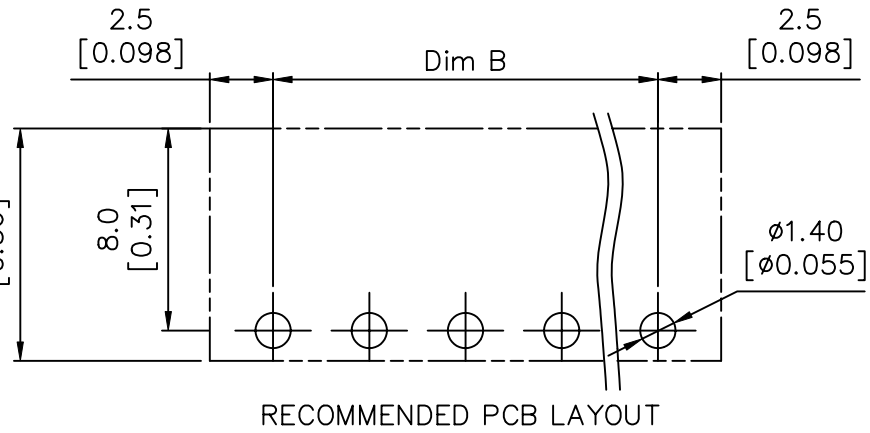
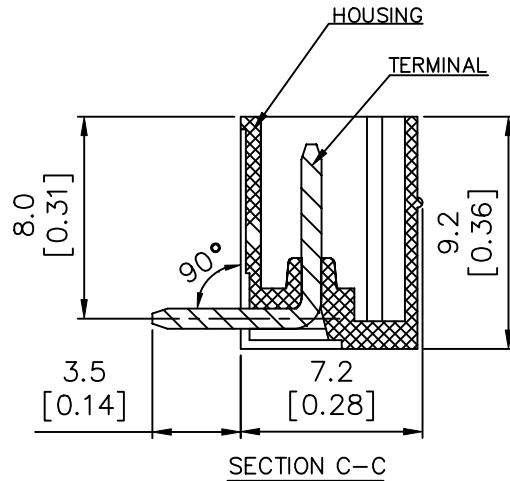
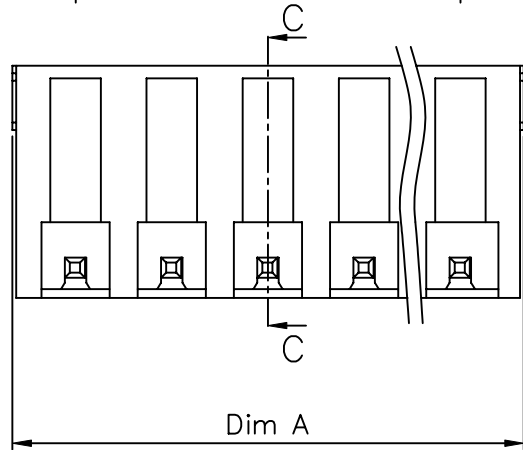
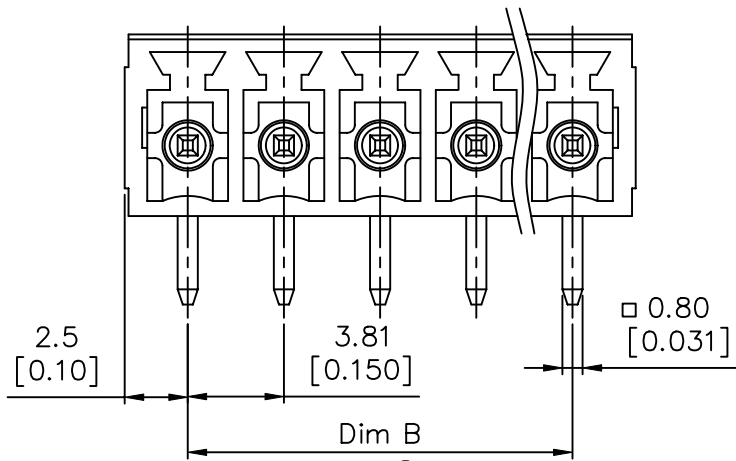

N = Number of poles
 Dim A = Dim B + 5.0 [0.197]
 Dim B = (N - 1) x 3.81 [0.150]

TOL.	Dim A	Dim B
2-6p	±0.15 [0.006]	
7-12p	±0.20 [0.008]	
13-16p	±0.25 [0.010]	
17-24p	±0.30 [0.012]	

Material		Spec ref		
Mat code		✓	tolerance	projection
Heattreat				MM
Plating/Finish			⊕	←
Dr	BEER FU 062509		size	A4
Eng	BEER FU 062509	Product family		Scale
Chr	GARY HSIEH 062509	Model Name		ECN T10-0109
Appr	JOSEPH HSIA 062509	Model Revision		REL Level RELEASED
		title		dwg no
		TERMINAL BLOCK		20020110
		Pluggable socket, right angle		Rev. E
Pro/E file	catalog no	CUSTOMER		sheet 3 of 5

REV: 2008-04-17

FCI CONFIDENTIAL



This document is the property of and embodies CONFIDENTIAL and PROPRIETARY information of FCI. No part of the information shown on this document may be used in any way or disclosed to others without the written consent of FCI. Copyright FCI.

PRODUCT NUMBER	SERIES NAME	PITCH
20020110-GXXA01LF	06-500	5.00 mm

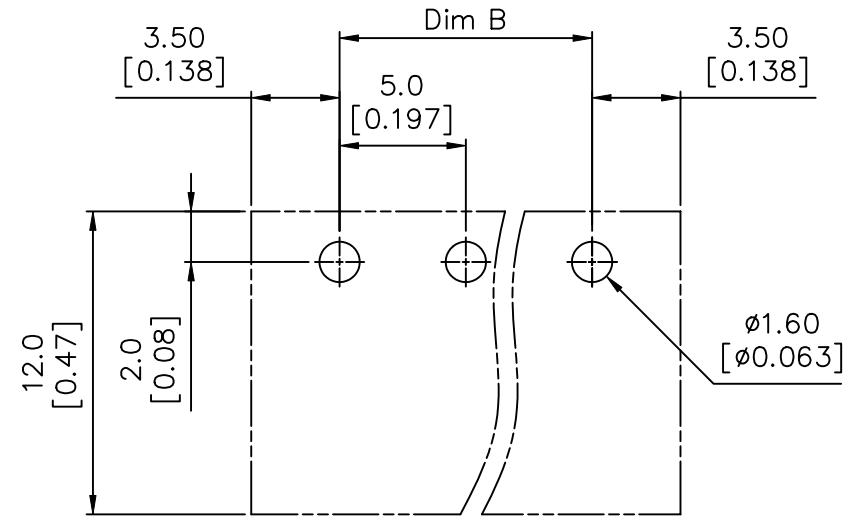
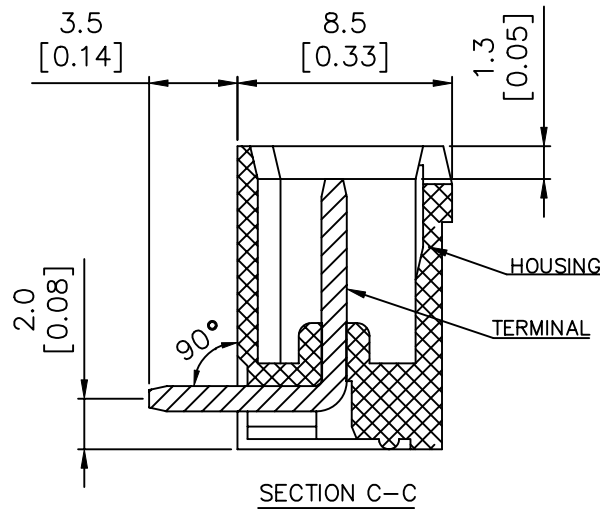
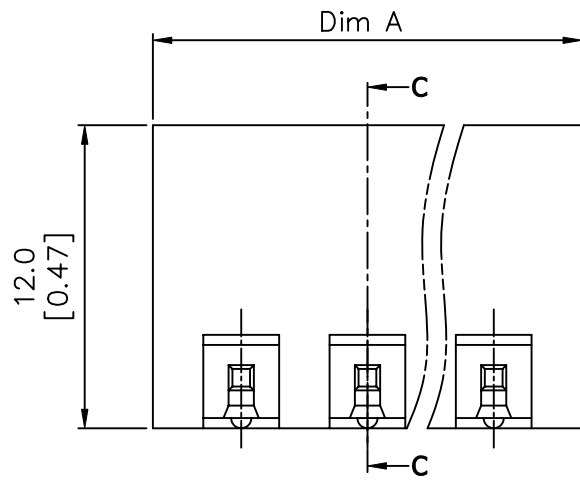
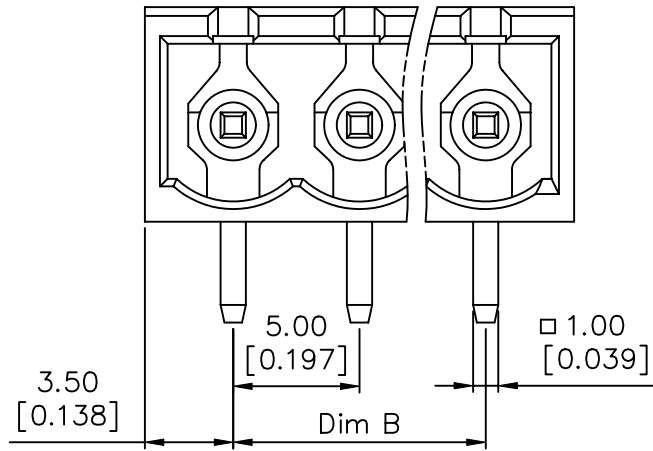

RECOMMENDED PCB LAYOUT

N = Number of poles
 Dim A = $N \times 5.0 [0.197] + 2.0 [0.193]$
 Dim B = $(N - 1) \times 5.0 [0.197]$

TOL.	Dim A	Dim B
2-6p	$\pm 0.15 [0.006]$	
7-12p	$\pm 0.25 [0.010]$	
13-16p	$\pm 0.35 [0.014]$	
17-24p	$\pm 0.40 [0.016]$	

Material		Spec ref		
Mat code		✓	tolerance	projection
Heattreat				MM
Plating/Finish				← MM
Dr	BEER FU 062509			size A4
Eng	BEER FU 062509	Product family		Scale
Chr	GARY HSIEH 062509	Model Name		ECN T10-0109
Appr	JOSEPH HSIA 062509	Model Revision		REL Level RELEASED
	title	TERMINAL BLOCK		dwg no
		Pluggable socket, right angle		20020110
Pro/E file	catalog no	CUSTOMER		Rev. E
		sheet 4 of 5		

REV: 2008-04-17

FCI CONFIDENTIAL



This document is the property of and embodies CONFIDENTIAL and PROPRIETARY information of FCI. No part of the information shown on this document may be used in any way or disclosed to others without the written consent of FCI. Copyright FCI.

PRODUCT NUMBER	SERIES NAME	PITCH
20020110-HXXXA01LF	06-508	5.08 mm

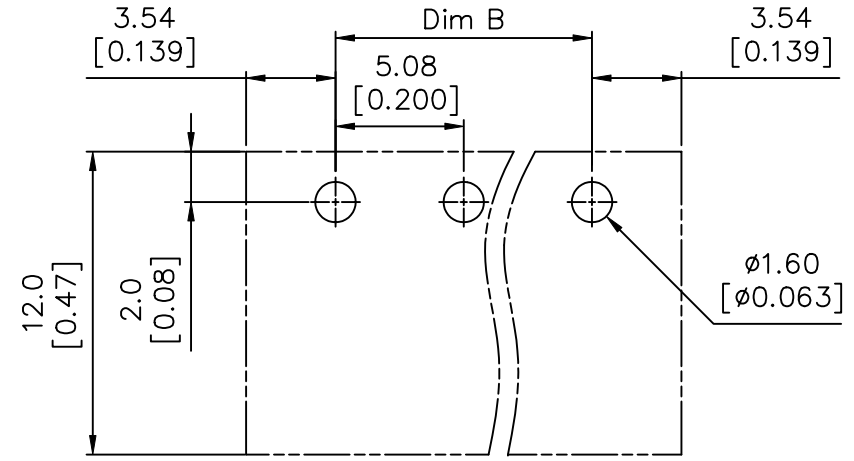
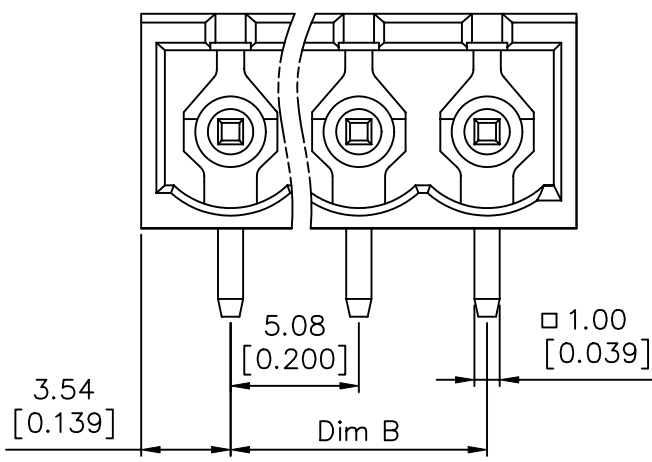

RECOMMENDED PCB LAYOUT

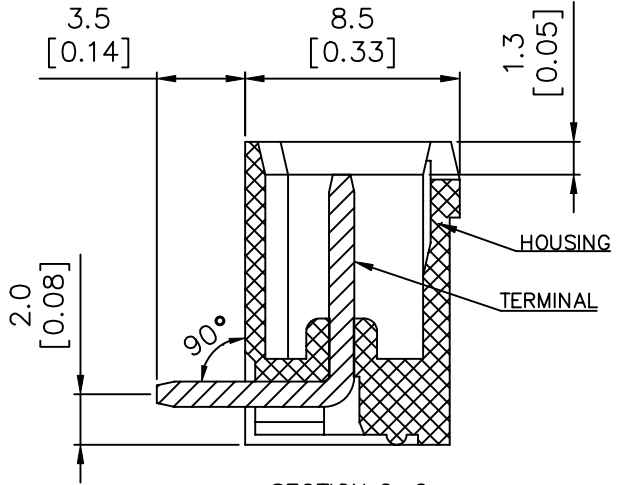
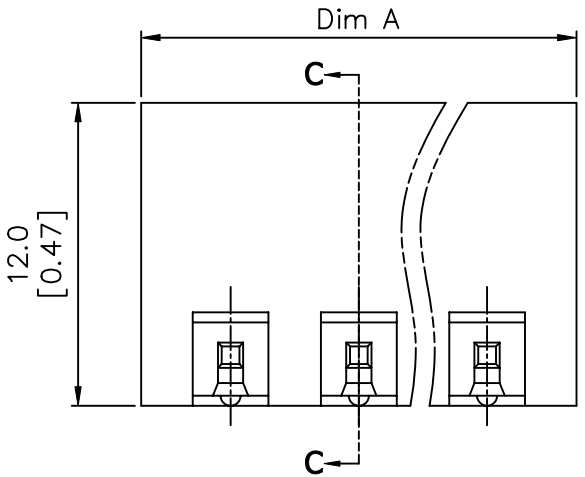

SECTION C-C

N = Number of poles
 Dim A = $N \times 5.08 [0.200] + 2.0 [0.193]$
 Dim B = $(N - 1) \times 5.08 [0.200]$

TOL.	Dim A	Dim B
2-6p	$\pm 0.15 [0.006]$	
7-12p	$\pm 0.25 [0.010]$	
13-18p	$\pm 0.35 [0.014]$	
19-24p	$\pm 0.40 [0.016]$	

Material		Spec ref		
Mat code		✓	tolerance	projection
Heattreat				MM
Plating/Finish				← MM
Dr	BEER FU 062509	size		A4 Scale
Eng	BEER FU 062509	Product family		
Chr	GARY HSIEH 062509	Model Name		ECN T10-0109
Appr	JOSEPH HSIA 062509	Model Revision		REL Level RELEASED
	title	dwg no	20020110	Rev. E
Pro/E file	catalog no	CUSTOMER		sheet 5 of 5

REV: 2008-04-17



Компания «ЭлектроПласт» предлагает заключение долгосрочных отношений при поставках импортных электронных компонентов на взаимовыгодных условиях!

Наши преимущества:

- Оперативные поставки широкого спектра электронных компонентов отечественного и импортного производства напрямую от производителей и с крупнейших мировых складов;
- Поставка более 17-ти миллионов наименований электронных компонентов;
- Поставка сложных, дефицитных, либо снятых с производства позиций;
- Оперативные сроки поставки под заказ (от 5 рабочих дней);
- Экспресс доставка в любую точку России;
- Техническая поддержка проекта, помощь в подборе аналогов, поставка прототипов;
- Система менеджмента качества сертифицирована по Международному стандарту ISO 9001;
- Лицензия ФСБ на осуществление работ с использованием сведений, составляющих государственную тайну;
- Поставка специализированных компонентов (Xilinx, Altera, Analog Devices, Intersil, Interpoint, Microsemi, Aeroflex, Peregrine, Syfer, Eurofarad, Texas Instrument, Miteq, Cobham, E2V, MA-COM, Hittite, Mini-Circuits, General Dynamics и др.);

Помимо этого, одним из направлений компании «ЭлектроПласт» является направление «Источники питания». Мы предлагаем Вам помощь Конструкторского отдела:

- Подбор оптимального решения, техническое обоснование при выборе компонента;
- Подбор аналогов;
- Консультации по применению компонента;
- Поставка образцов и прототипов;
- Техническая поддержка проекта;
- Защита от снятия компонента с производства.



Как с нами связаться

Телефон: 8 (812) 309 58 32 (многоканальный)

Факс: 8 (812) 320-02-42

Электронная почта: org@eplast1.ru

Адрес: 198099, г. Санкт-Петербург, ул. Калинина, дом 2, корпус 4, литера А.