

RECTANGULAR CONNECTORS

FCN-360 SERIES

■ FEATURES

- Many applications
Various connectors are available for connection by means of soldering, wire wrapping, crimping, PC board mounting, and insulation displacement connection (IDC). The user can choose a plug and jack combination that best meet each application.
- Small size for high-density mounting
The connectors are small with a contact and terminal pitch of 2.54 mm (0.100 in.) between pins and between rows and are thus well suited for high-density mounting.
- Sturdy shell guide
Sturdy shell guides are used to prevent mismatching and to protect the pins.
- Excellent cost performance
Streamlined design and automated manufacturing, including use of partial solder plating, provide excellent cost performance.

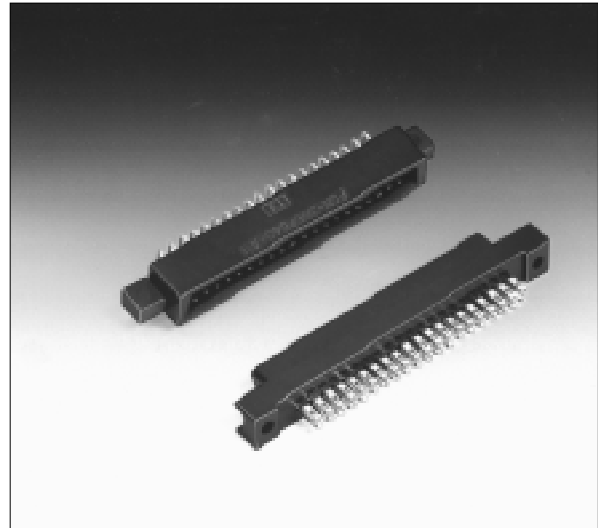

■ SPECIFICATIONS

Item	Specification	
Operating temperature range	-55°C to +85°C	
Current Rating	DC 3 A (IDC type: 1 A)	
Voltage Rating	AC 250 V	
Contact resistance	15 mΩ max. (DC 6 V, 0.3 A)	
Insulation resistance	1000 MΩ min. (DC 500 V)	
Dielectric withstanding voltage	AC 500 V for 1 minute	
Insertion force	2.5 kg max. (8 contacts), 20 kg max. (64 contacts)	
Withdrawal force	0.3 kg min. (8 contacts), 2.3 kg min. (64 contacts)	
Applicable wire	Soldering	φ0.60 mm (0.024 in.) max, AWG #23 or less
	Wire-wrapping	φ0.32 mm (0.013 in.) to φ0.26 mm (0.010 in.), AWG #28 to #30
	Crimping	Standard contacts φ0.51 mm (0.020 in.) to φ0.32 mm (0.013 in.), AWG #24 to #28, insulator φ1.2 mm (0.047 in.) max. Contacts for thick wires φ0.64 mm (0.025 in.) to φ0.32 mm (0.013 in.), AWG #22 to #28, insulator φ1.7 (0.067 in.) max.
	IDC	Flat cable 1.27 mm (0.050 in.) pitch, AWG #28 (stranded wire), AWG #30 (solid wire)
Applicable PC board	1.6 mm (0.063 in.) standard thick	

■ MATERIALS

Item	Material
Insulator	Polyester (363J: PC94V-2)
Conductor	Copper alloy
Plating	Gold plating, silver plating

FCN-360 Series

APPLICATION EXAMPLE

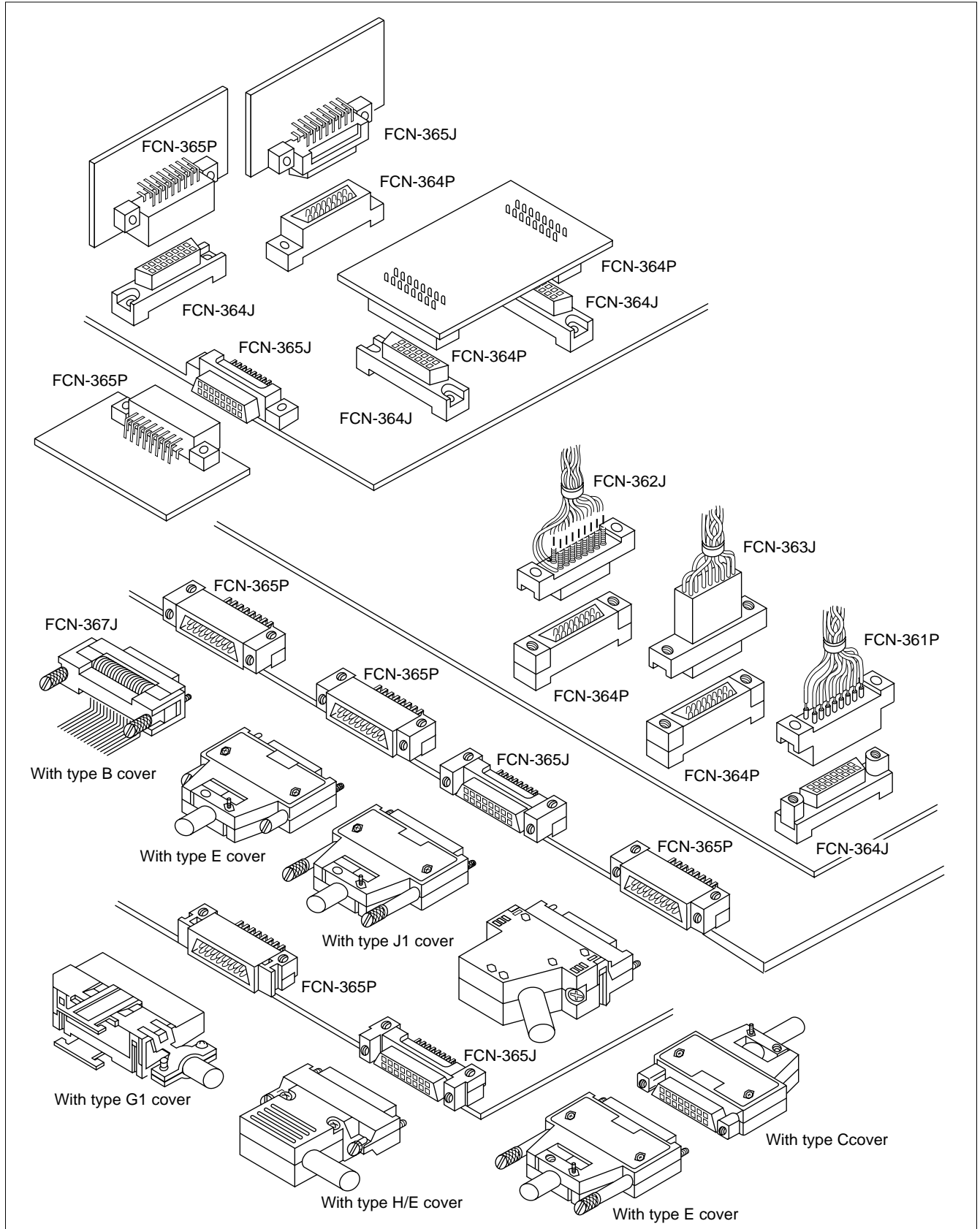

FCN-360 Series

COVER (TYPE B)

■ DIMENSIONS

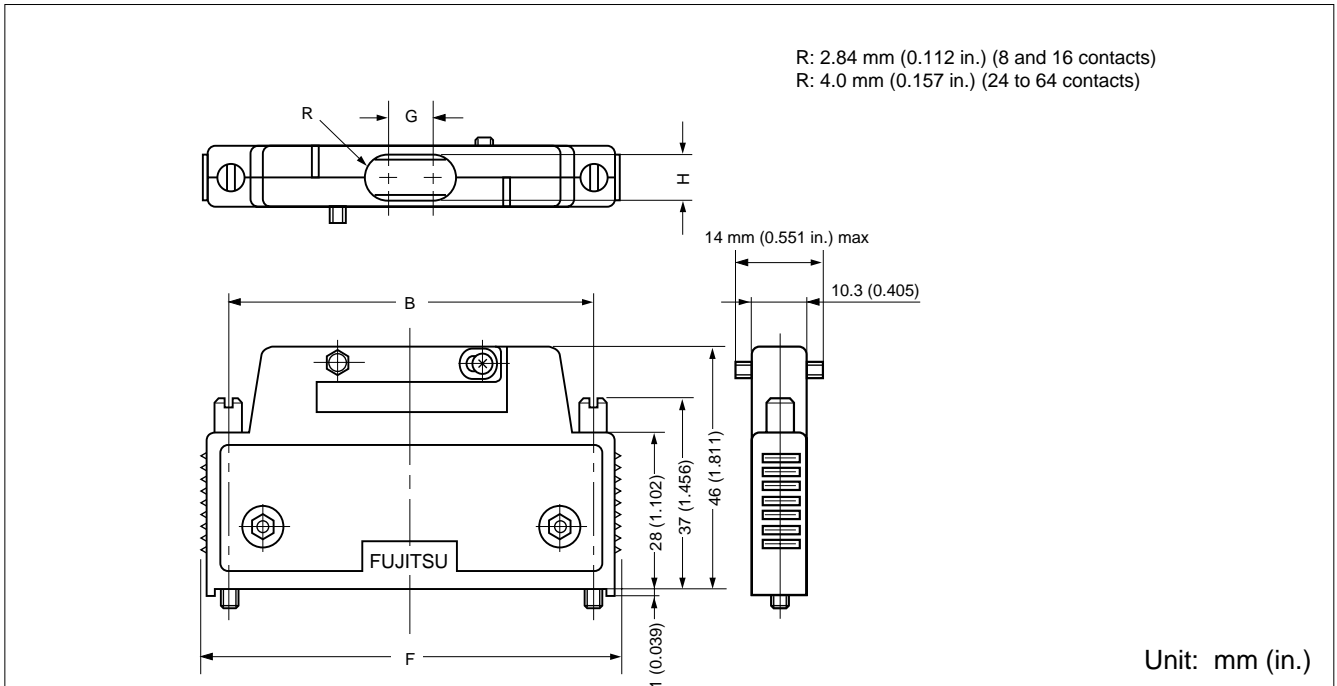

■ EXPLODED VIEW

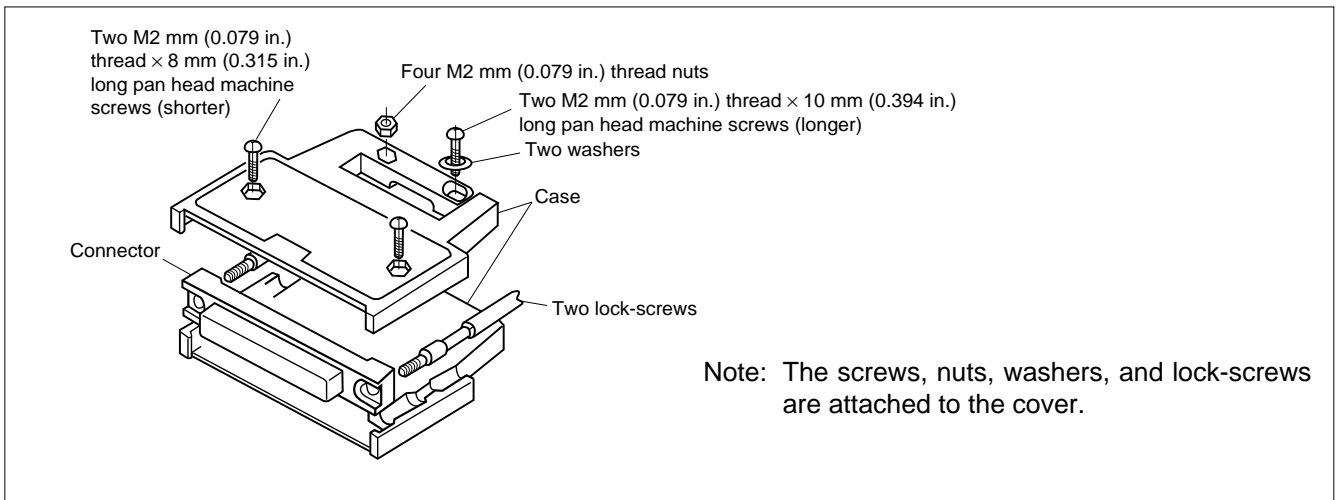

■ PART NUMBERS AND DIMENSIONS

Number of contacts	Part number	Dimensions: mm (in.)			
		B	F	G	H
8	FCN-360C008-B	23.34 (0.918)	32.08 (1.262)	—	∅ 5.7 (0.224)
16	FCN-360C016-B	33.50 (1.318)	42.24 (1.662)	—	∅ 5.7 (0.224)
24	FCN-360C024-B	43.66 (1.718)	52.40 (2.062)	—	∅ 8.0 (0.314)
32	FCN-360C032-B	53.82 (2.118)	62.56 (2.462)	2.0 (0.078)	8.0 (0.314)
40	FCN-360C040-B	63.98 (2.518)	72.72 (2.862)	6.0 (0.236)	8.0 (0.314)
48	FCN-360C048-B	74.14 (2.918)	82.88 (3.262)	10.0 (0.393)	8.0 (0.314)
56	FCN-360C056-B	84.30 (3.318)	93.04 (3.662)	14.0 (0.551)	8.0 (0.314)
64	FCN-360C064-B	94.46 (3.718)	103.20 (4.062)	18.0 (0.708)	8.0 (0.314)

FCN-360 Series

COVER FOR CABLE TO CABLE CONNECTION (TYPE C)

■ DIMENSIONS

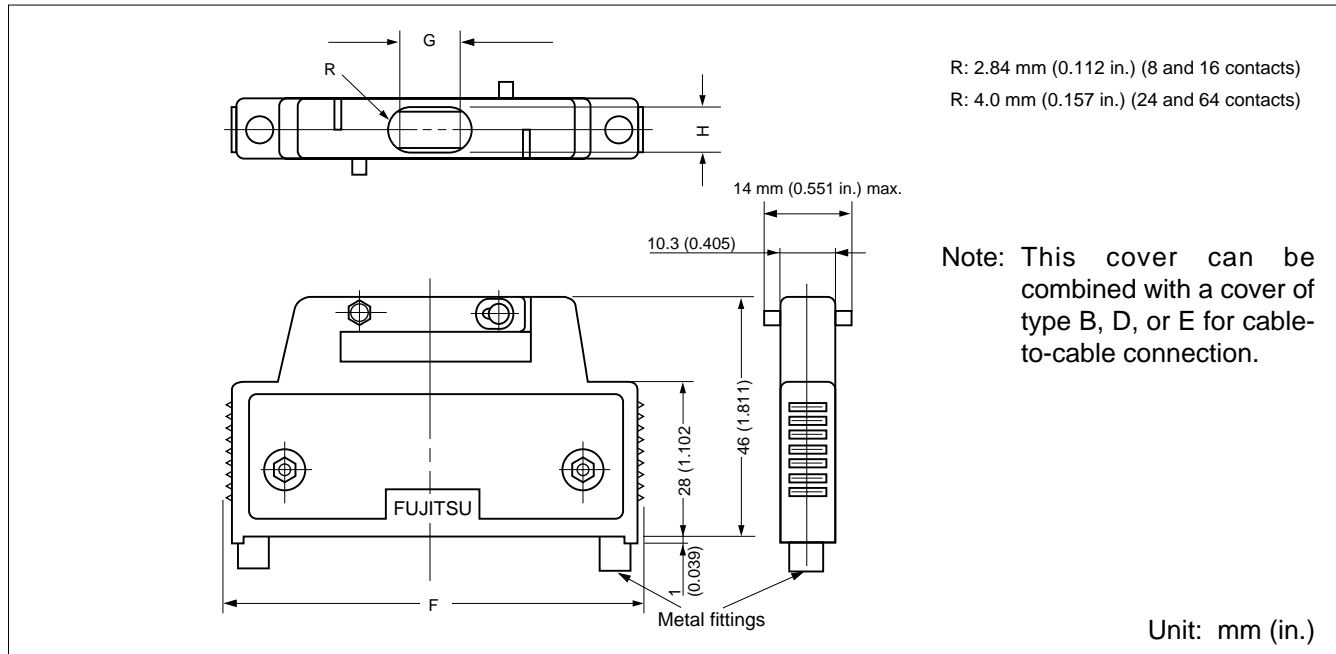

■ EXPLODED VIEW

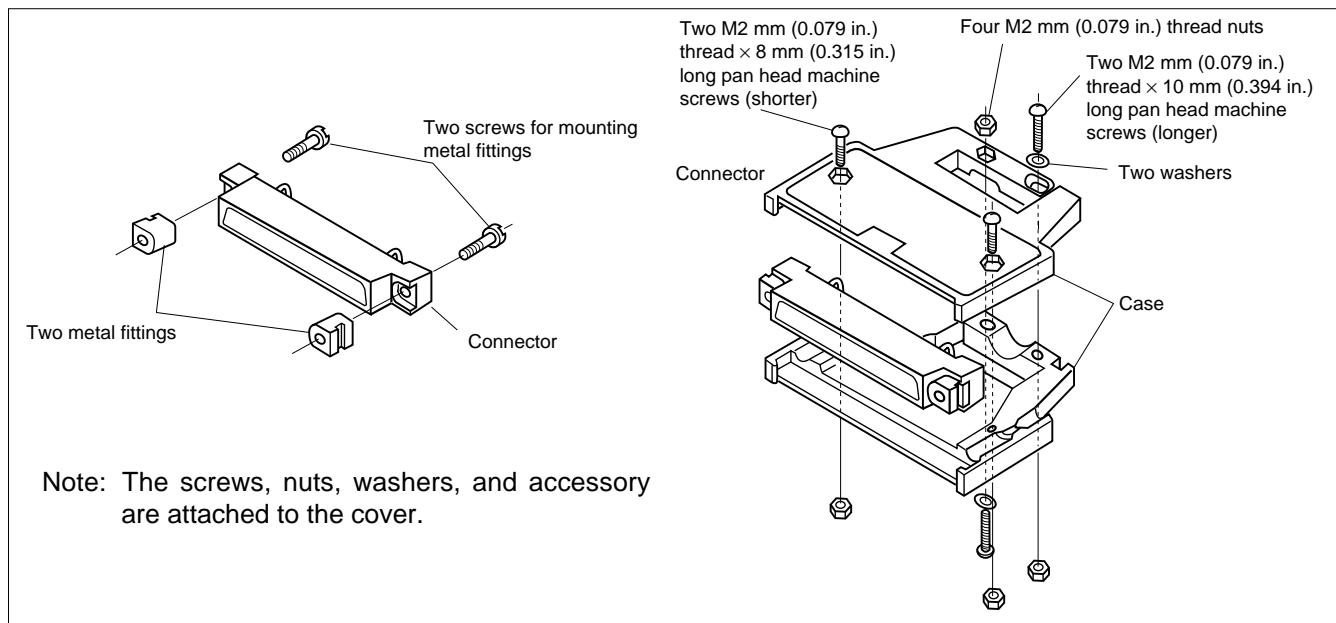

■ PART NUMBERS AND DIMENSIONS

Number of contacts	Part number	Dimensions: mm (in.)		
		F	G	H
8	FCN-360C008-C	32.08 (1.262)	—	φ 5.7 (0.224)
16	FCN-360C016-C	42.24 (1.662)	—	φ 5.7 (0.224)
24	FCN-360C024-C	52.40 (2.062)	—	φ 8.0 (0.314)
32	FCN-360C032-C	62.56 (2.462)	2.0 (0.078)	8.0 (0.314)
40	FCN-360C040-C	72.72 (2.862)	6.0 (0.236)	8.0 (0.314)
48	FCN-360C048-C	82.88 (3.262)	10.0 (0.393)	8.0 (0.314)
56	FCN-360C056-C	93.04 (3.662)	14.0 (0.551)	8.0 (0.314)
64	FCN-360C064-C	103.20 (4.062)	18.0 (0.708)	8.0 (0.314)

FCN-360 Series

COVER (WIDE OPENING TYPE) (TYPE D)

■ DIMENSIONS

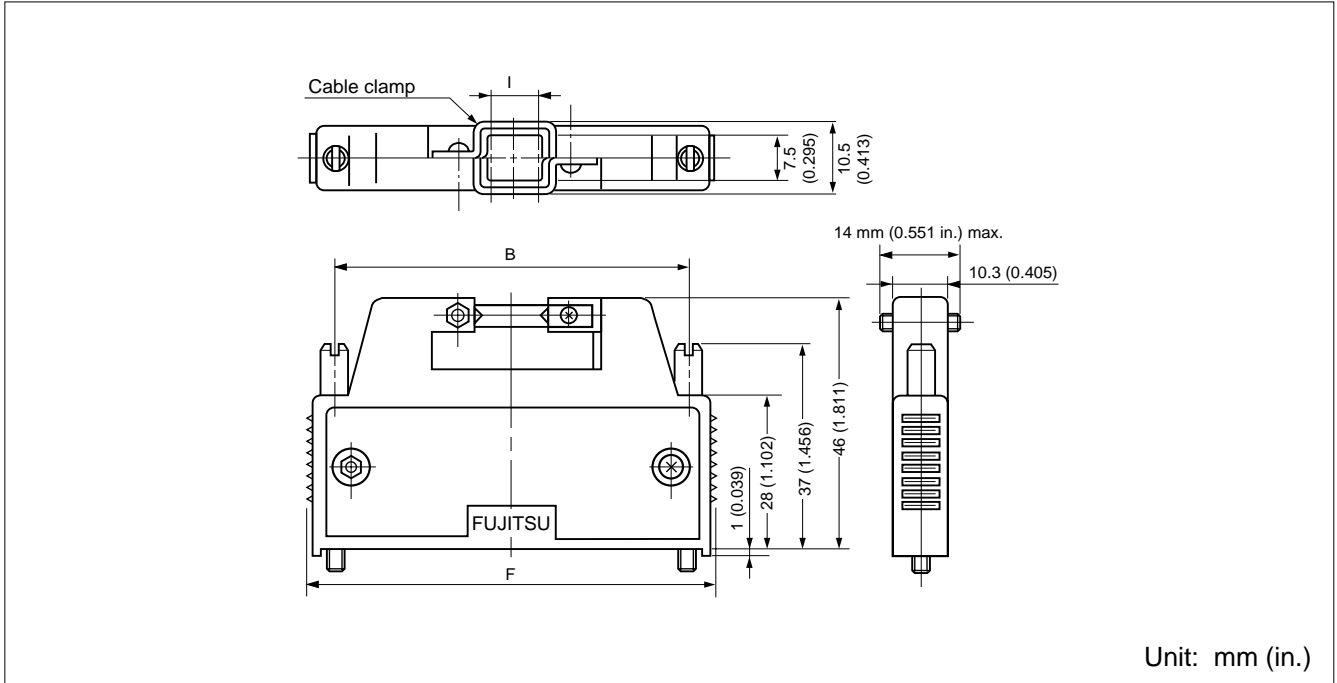

■ EXPLODED VIEW

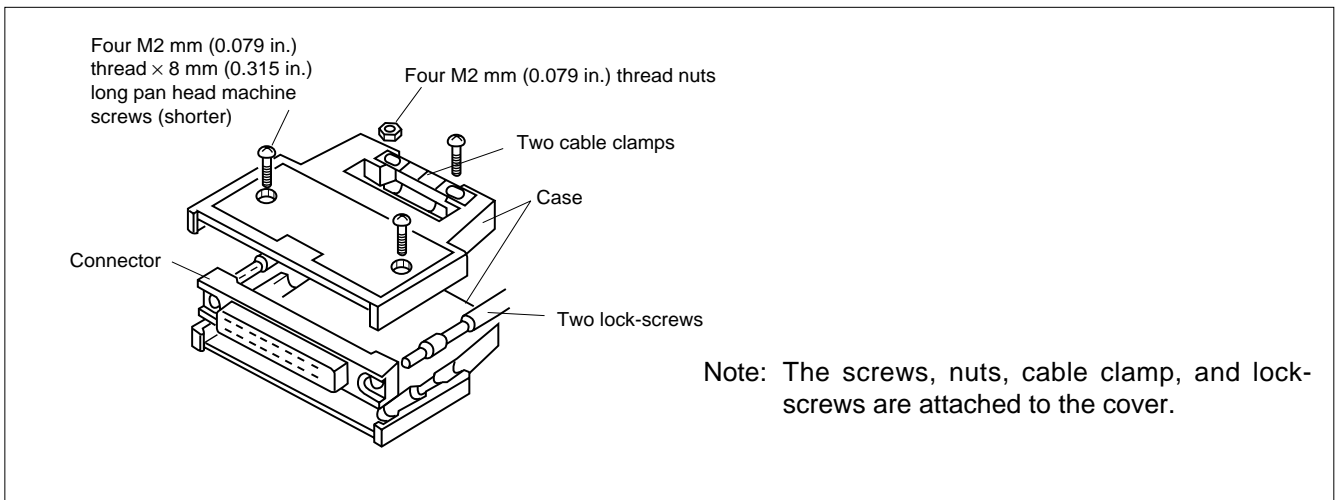

■ PART NUMBERS AND DIMENSIONS

Number of contacts	Part number	Dimensions: mm (in.)		
		B	F	I
40	FCN-360C040-D	63.98 (2.518)	72.72 (2.862)	8.0 (0.314)
48	FCN-360C048-D	74.14 (2.918)	82.88 (3.262)	12.0 (0.472)
56	FCN-360C056-D	84.30 (3.318)	93.04 (3.662)	16.0 (0.629)
64	FCN-360C064-D	94.46 (3.718)	103.20 (4.062)	20.0 (0.789)

FCN-360 Series

COVER (LONG-SCREW TYPE) (TYPE E)

■ DIMENSIONS

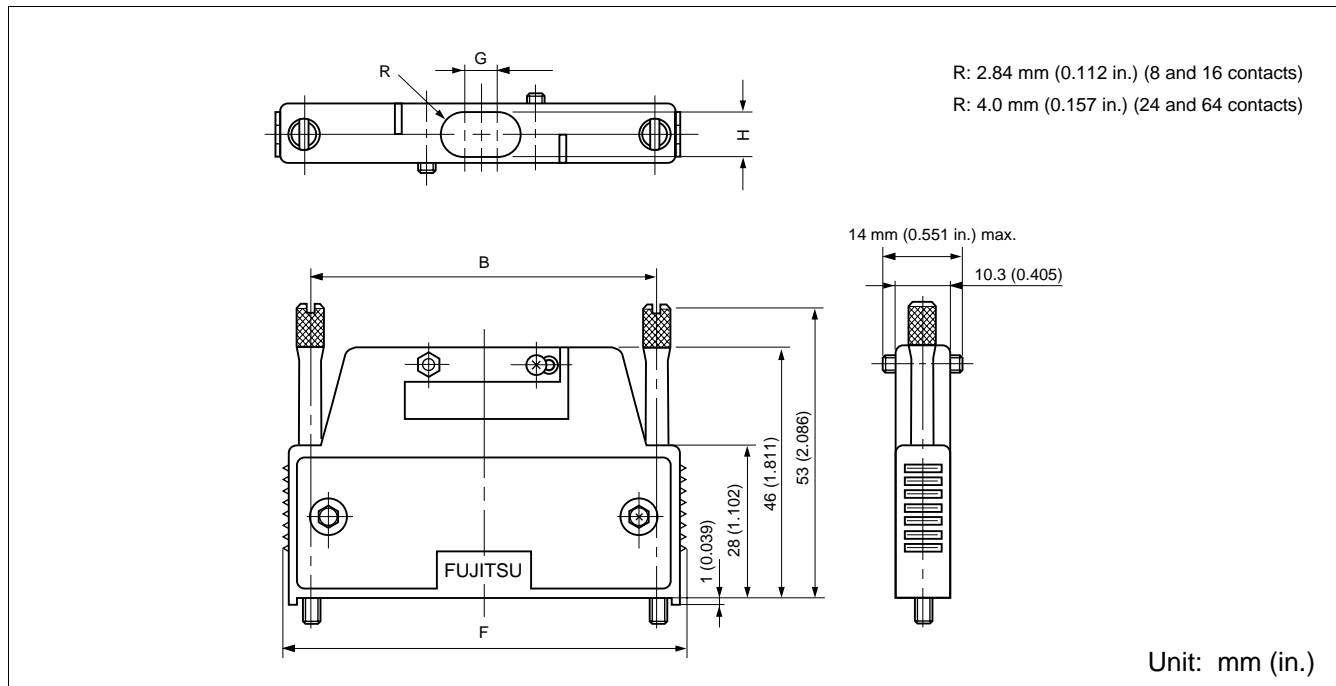

■ EXPLODED VIEW

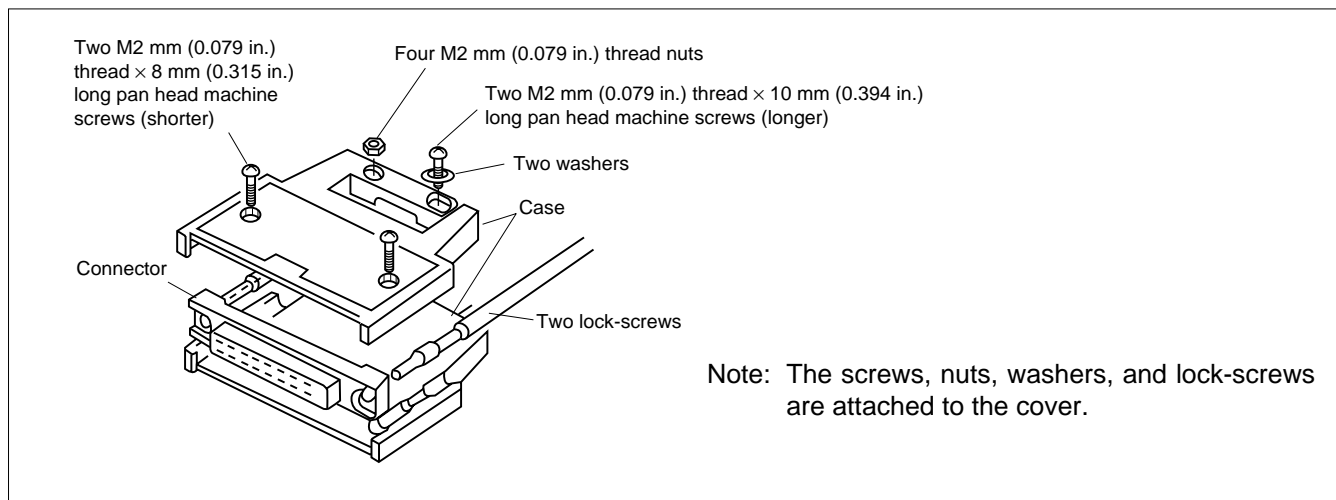

■ PART NUMBERS AND DIMENSIONS

Number of contacts	Part number	Dimensions: mm (in.)			
		B	F	G	H
8	FCN-360C008-E	23.34 (0.918)	32.08 (1.262)	—	φ 5.7 (0.224)
16	FCN-360C016-E	33.50 (1.318)	42.24 (1.662)	—	φ 5.7 (0.224)
24	FCN-360C024-E	43.66 (1.718)	52.40 (2.062)	—	φ 8.0 (0.314)
32	FCN-360C032-E	53.82 (2.118)	62.56 (2.462)	2.0 (0.078)	8.0 (0.314)
40	FCN-360C040-E	63.98 (2.518)	72.72 (2.862)	6.0 (0.236)	8.0 (0.314)
48	FCN-360C048-E	74.14 (2.918)	82.88 (3.262)	10.0 (0.393)	8.0 (0.314)
56	FCN-360C056-E	84.30 (3.318)	93.04 (3.662)	14.0 (0.551)	8.0 (0.314)
64	FCN-360C064-E	94.46 (3.718)	103.20 (4.062)	18.0 (0.708)	8.0 (0.314)

COVER (STRAIGHT CABLE-OUT COVER) (TYPE F)

■ DIMENSIONS

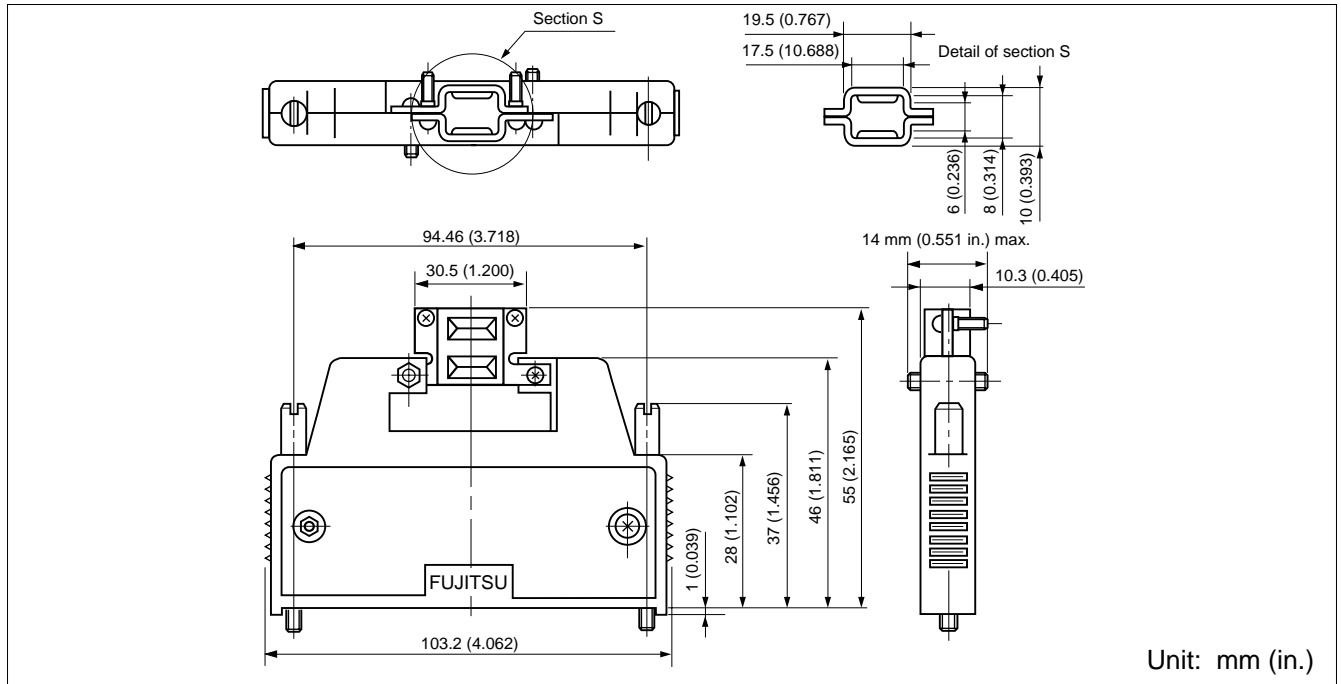

■ EXPLODED VIEW

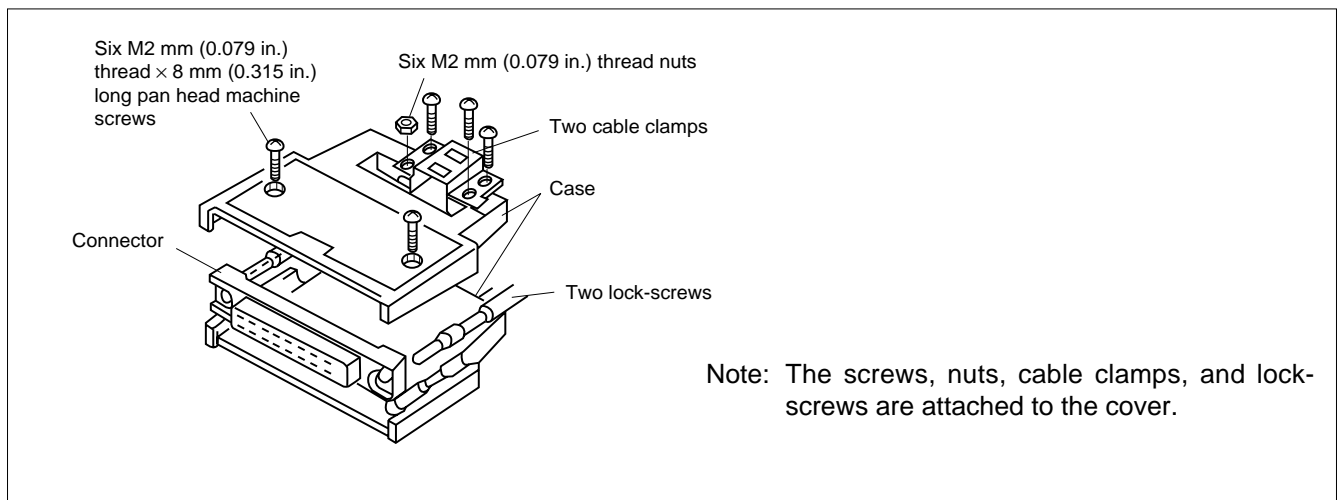

■ PART NUMBER

FCN-360C064-F

FCN-360 Series

COVER (RIGHT ANGLE CABLE-OUT COVER) (TYPE G1)

■ DIMENSIONS

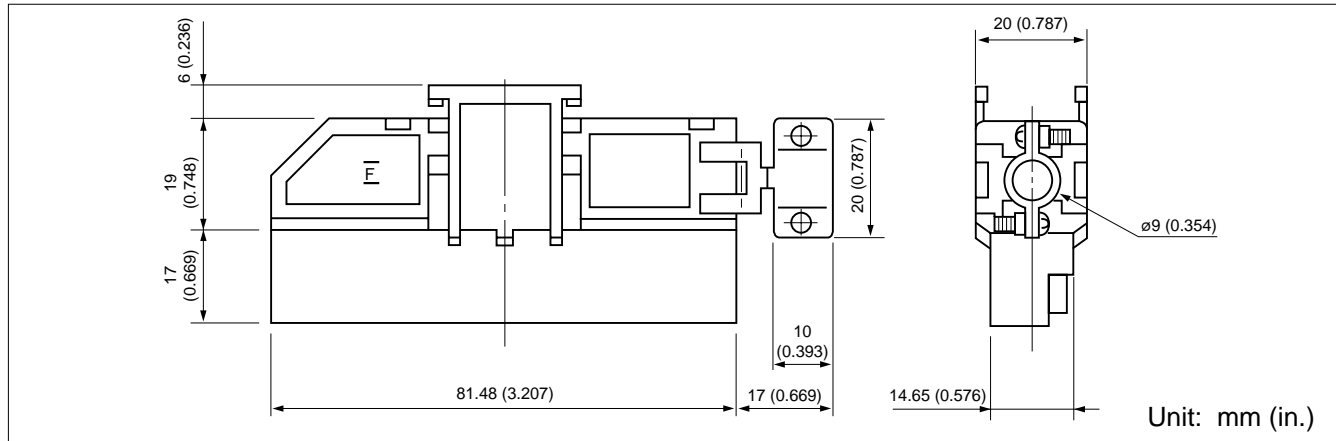

■ EXPLODED VIEW

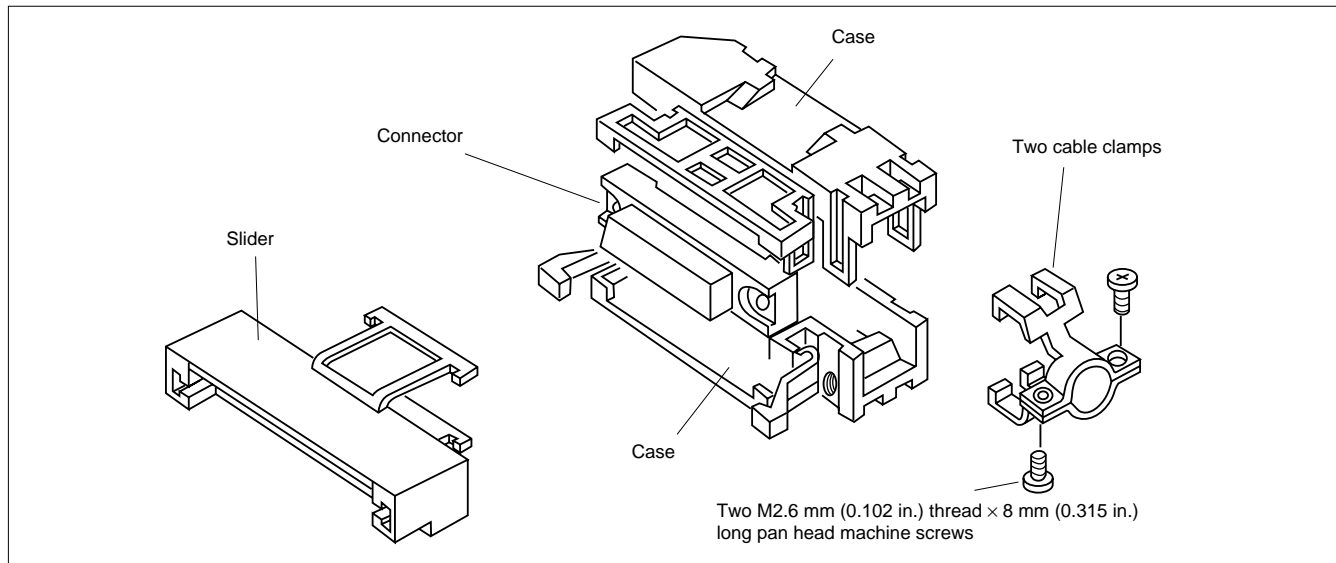

■ LOCKED STATE

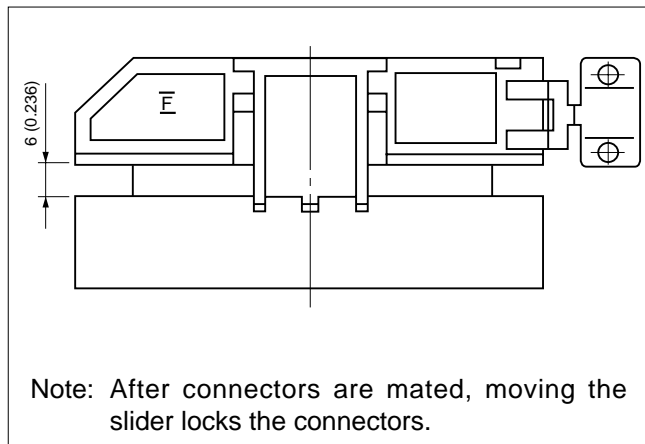

■ METAL FITTINGS

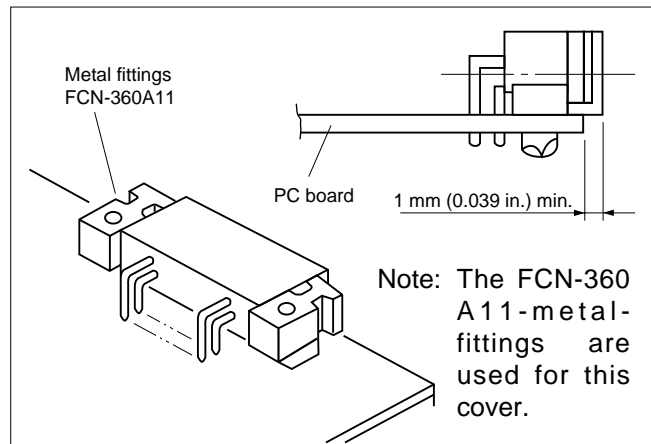

■ PART NUMBER

FCN-360C040-G1

FCN-360 Series

COVER (RIGHT ANGLE CABLEOUT COVER) (TYPE H/E)

■ DIMENSIONS

Material: Zinc die cast

Plating: Nickel plating

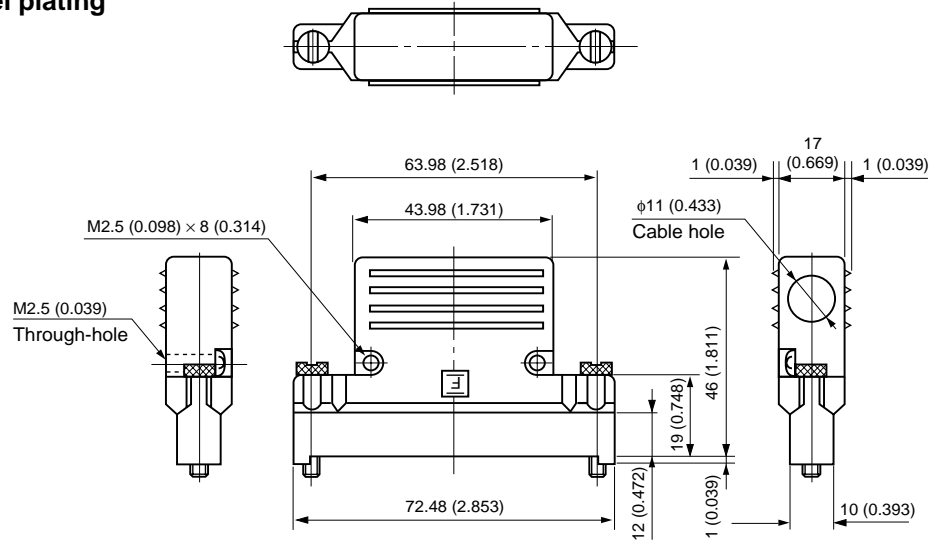

Unit: mm (in.)

■ EXPLODED VIEW

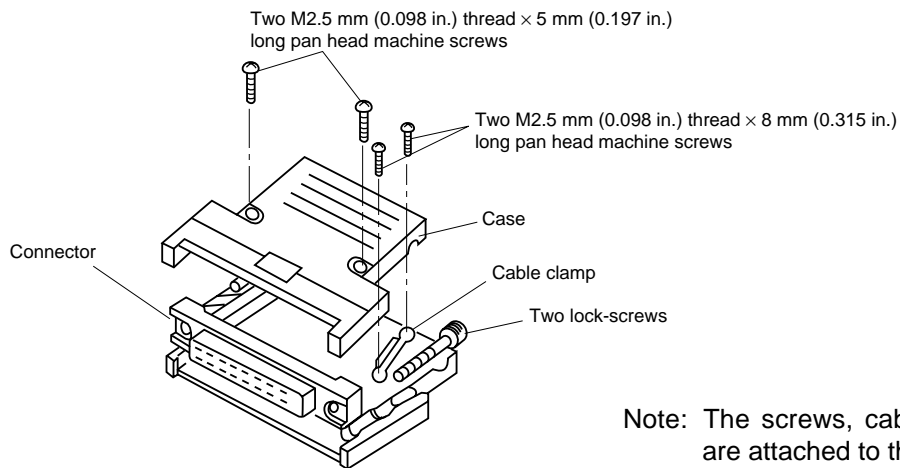

Note: The screws, cable clamp, and lock-screws are attached to the cover.

■ PART NUMBER

FCN-360C040-H/E

FCN-360 Series

COVER (OBTUSE ANGLE CABLE-OUT COVER (40 CONTACTS ONLY)) (TYPE J1)

■ DIMENSIONS

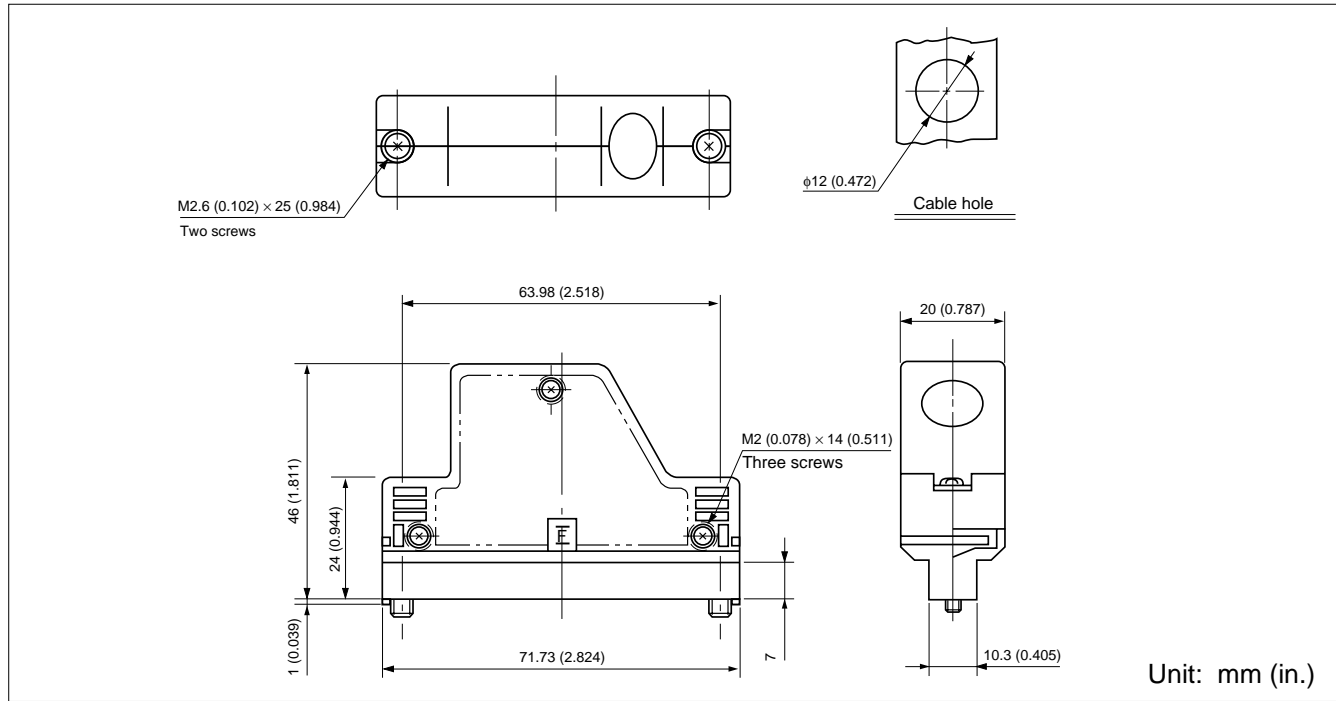

■ EXPLODED VIEW

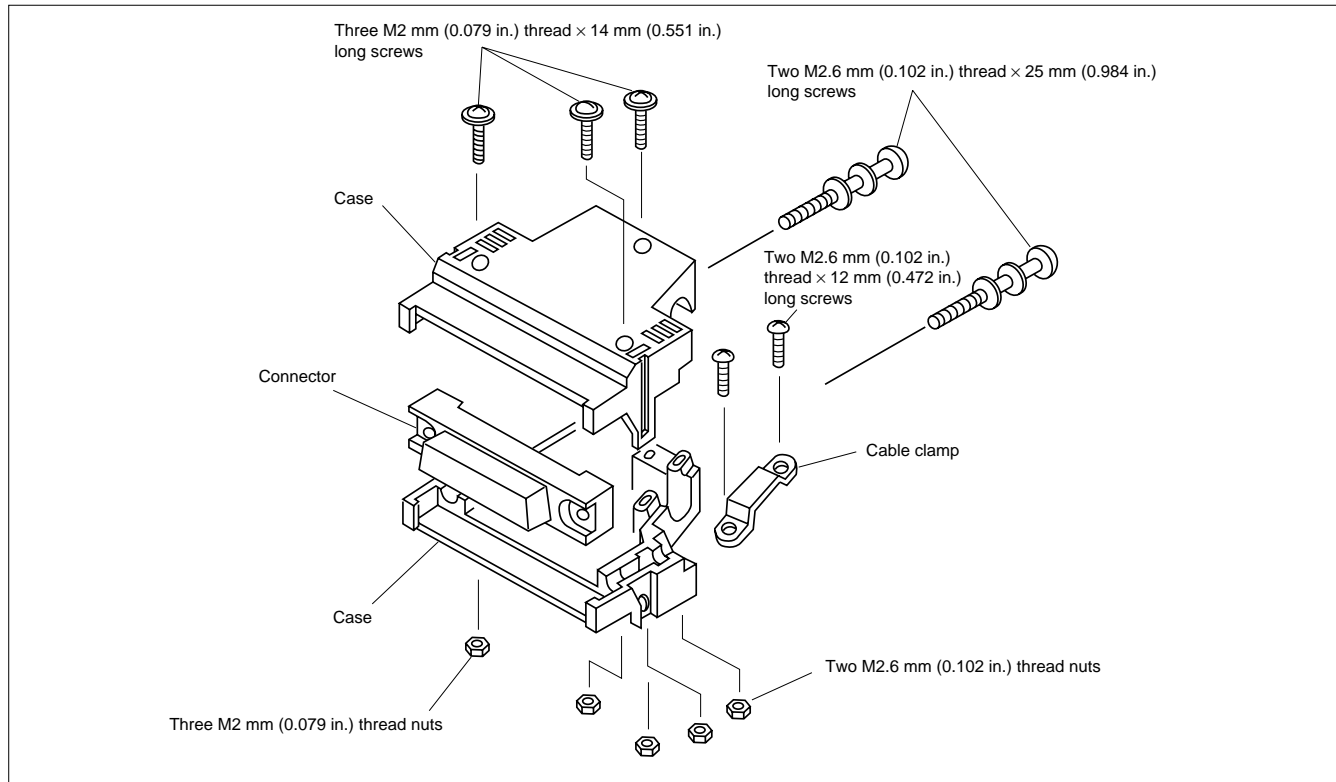

■ PART NUMBER

FCN-360C040-J1

Fujitsu Components International Headquarter Offices

Japan

Fujitsu Component Limited
Gotanda-Chuo Building
3-5, Higashigotanda 2-chome, Shinagawa-ku
Tokyo 141, Japan
Tel: (81-3) 5449-7010
Fax: (81-3) 5449-2626
Email: promothq@ft.ed.fujitsu.com
Web: www.fcl.fujitsu.com

North and South America

Fujitsu Components America, Inc.
250 E. Caribbean Drive
Sunnyvale, CA 94089 U.S.A.
Tel: (1-408) 745-4900
Fax: (1-408) 745-4970
Email: marcom@fcai.fujitsu.com
Web: www.fcai.fujitsu.com

Europe

Fujitsu Components Europe B.V.
Diamantlaan 25
2132 WV Hoofddorp
Netherlands
Tel: (31-23) 5560910
Fax: (31-23) 5560950
Email: info.marketing@fceu.fujitsu.com
Web: www.fceu.fujitsu.com

Asia Pacific

Fujitsu Components Asia Ltd.
102E Pasir Panjang Road
#04-01 Citilink Warehouse Complex
Singapore 118529
Tel: (65) 375-8560
Fax: (65) 273-3021
Email: fcal@fcal.fujitsu.com
www.fcal.fujitsu.com

© 2001 Fujitsu Components America, Inc. All company and product names are trademarks or registered trademarks of their respective owners. Rev. 09/2001



Компания «ЭлектроПласт» предлагает заключение долгосрочных отношений при поставках импортных электронных компонентов на взаимовыгодных условиях!

Наши преимущества:

- Оперативные поставки широкого спектра электронных компонентов отечественного и импортного производства напрямую от производителей и с крупнейших мировых складов;
- Поставка более 17-ти миллионов наименований электронных компонентов;
- Поставка сложных, дефицитных, либо снятых с производства позиций;
- Оперативные сроки поставки под заказ (от 5 рабочих дней);
- Экспресс доставка в любую точку России;
- Техническая поддержка проекта, помощь в подборе аналогов, поставка прототипов;
- Система менеджмента качества сертифицирована по Международному стандарту ISO 9001;
- Лицензия ФСБ на осуществление работ с использованием сведений, составляющих государственную тайну;
- Поставка специализированных компонентов (Xilinx, Altera, Analog Devices, Intersil, Interpoint, Microsemi, Aeroflex, Peregrine, Syfer, Eurofarad, Texas Instrument, Miteq, Cobham, E2V, MA-COM, Hittite, Mini-Circuits, General Dynamics и др.);

Помимо этого, одним из направлений компании «ЭлектроПласт» является направление «Источники питания». Мы предлагаем Вам помощь Конструкторского отдела:

- Подбор оптимального решения, техническое обоснование при выборе компонента;
- Подбор аналогов;
- Консультации по применению компонента;
- Поставка образцов и прототипов;
- Техническая поддержка проекта;
- Защита от снятия компонента с производства.



Как с нами связаться

Телефон: 8 (812) 309 58 32 (многоканальный)

Факс: 8 (812) 320-02-42

Электронная почта: org@eplast1.ru

Адрес: 198099, г. Санкт-Петербург, ул. Калинина, дом 2, корпус 4, литера А.