

Toshiba BiCD process integrated circuit silicon monolithic

# TB67S249FTG

## Active Gain Control Clock-in control Bipolar stepping motor driver

The TB67S249FTG is a clock-in controlled bipolar stepping motor driver with a built-in Active Gain Control architecture. The TB67S249FTG also has an internal current feedback control (ACDS) which enables the driver to control the motor current without using a sense resistor. Using the BiCD process, the TB67S249FTG is rated at 50 V, 4.5 A.

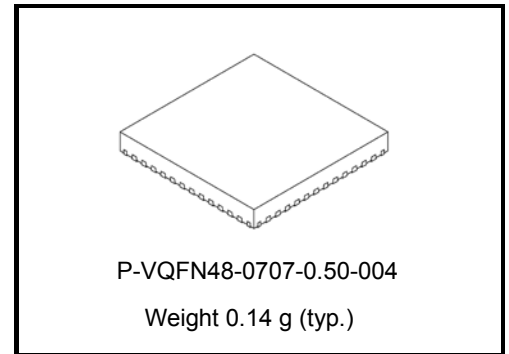

### Features

- Built-in Anti-stall architecture (AGC: Active Gain Control)
- Built-in sense resistor less current control architecture (ACDS: Advanced Current Detection System)
- Low  $R_{ds(on)}$  MOSFET (High side+ Low side=0.33  $\Omega$  (typ.))
- Built-in micro stepping control. (Full, Half (a), Half (b), Quarter, 1/8, 1/16, 1/32 step resolution)
- Multi error detect functions (Thermal shutdown (TSD), Over current protection (ISD), Power-on-reset (POR), Motor load open (OPD))
- Error detection status output (Error Output)
- Internal VCC (5 V) regulator enables the driver to operate with a single power supply (VM).
- Adjustable constant current PWM frequency using external components
- Small package with thermal pad on back side (QFN48: 7.0 mm x 7.0 mm)

Note: Please consider the heat condition when using the TB67S249FTG.

### Pin assignment

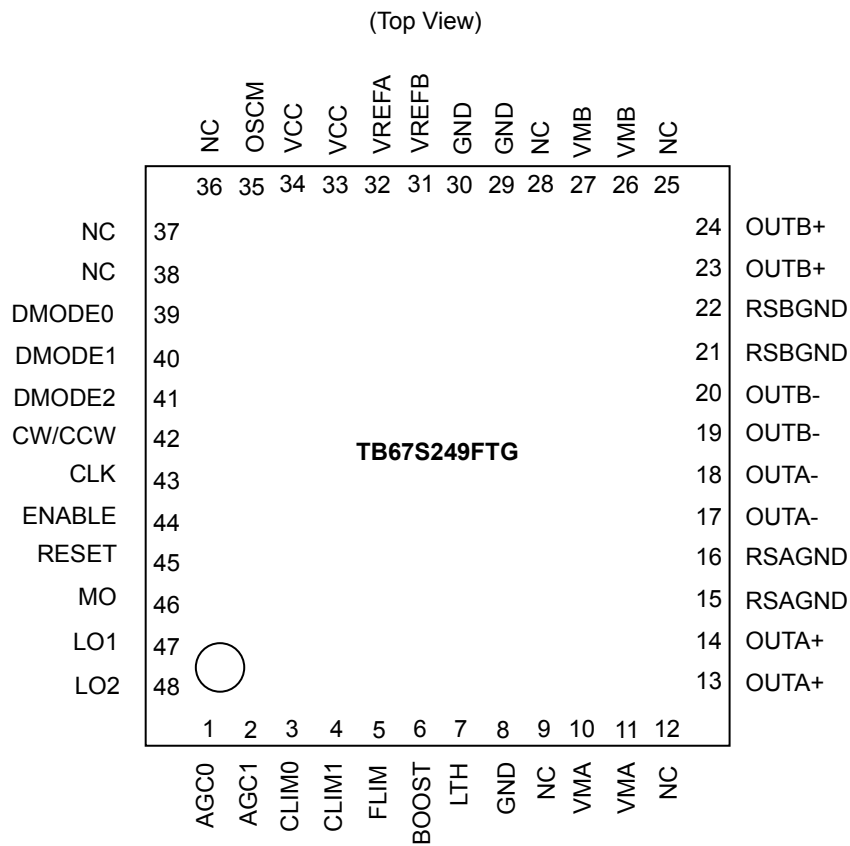

Note: Please solder the corner pad and the rear thermal pad of the QFN package, to the GND pattern of the PCB.

## Pin description

Pin No	Pin name	Pin function
1	AGC0	Active Gain Control setup pin No.0
2	AGC1	Active Gain Control setup pin No.1
3	CLIM0	AGC current limiter setup pin No.0
4	CLIM1	AGC current limiter setup pin No.1
5	FLIM	AGC frequency limiter setup pin
6	BOOST	AGC current boost setup pin
7	LTH	AGC threshold setup pin
8	GND	Ground pin
9	NC	Non connection
10	VMA	Motor power supply input pin
11	VMA	Motor power supply input pin
12	NC	Non connection
13	OUTA+	Ach motor output (+) pin
14	OUTA+	Ach motor output (+) pin
15	RSAGND	Ach motor power ground pin
16	RSAGND	Ach motor power ground pin
17	OUTA-	Ach motor output (-) pin
18	OUTA-	Ach motor output (-) pin
19	OUTB-	Bch motor output (-) pin
20	OUTB-	Bch motor output (-) pin
21	RSBGND	Bch motor power ground pin
22	RSBGND	Bch motor power ground pin
23	OUTB+	Bch motor output (+) pin
24	OUTB+	Bch motor output (+) pin
25	NC	Non connection
26	VMB	Motor power supply input pin
27	VMB	Motor power supply input pin
28	NC	Non connection
29	GND	Ground pin
30	GND	Ground pin
31	VREFB	Bch current threshold reference pin
32	VREFA	Ach current threshold reference pin
33	VCC	Internal regulator voltage monitor pin
34	VCC	Internal regulator voltage monitor pin
35	OSCM	Internal oscillator frequency monitor and setting pin
36	NC	Non connection
37	NC	Non connection
38	NC	Non connection
39	DMODE0	Step resolution setting pin No.0
40	DMODE1	Step resolution setting pin No.1
41	DMODE2	Step resolution setting pin No.2
42	CW/CCW	Current direction setup pin
43	CLK	Step clock input pin
44	ENABLE	Motor output ON/OFF pin
45	RESET	Electrical angle initialize pin
46	MO	Electrical angle monitor pin
47	LO1	Error flag output pin No.1
48	LO2	Error flag output pin No.2

Note: Please leave the NC pins open and do not connect any PCB pattern.

Note: For pins with the same pin name; connect the pins together at the nearest point of the driver.

## Block diagram

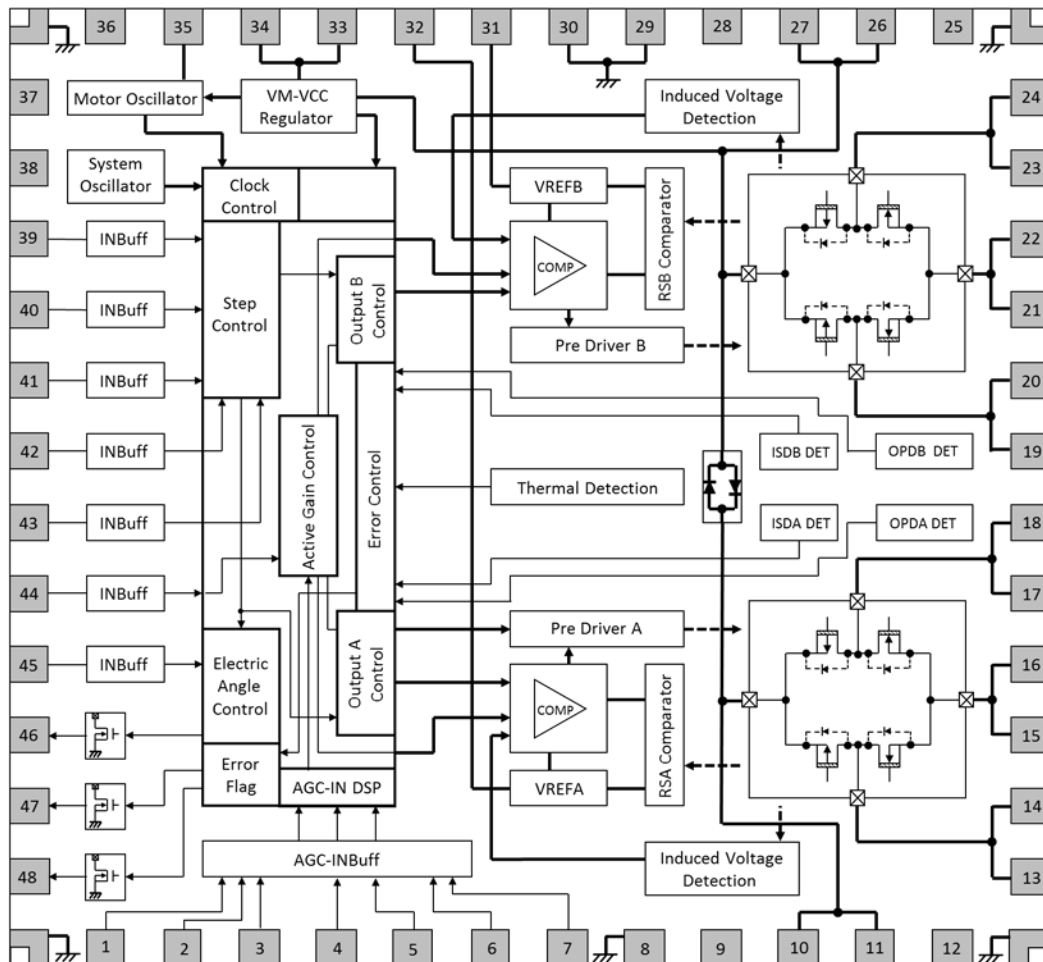

Some of the functional blocks, circuits, or constants in the block diagram may be omitted or simplified for explanatory purpose.

Note: All the grounding wires of the TB67S249FTG should run on the solder mask on the PCB and be externally terminated at only one point. Also, a grounding method should be considered for efficient heat dissipation.

Careful attention should be paid to the layout of the output, VM and GND traces, to avoid short circuits across output pins or to the power supply or ground. If such a short circuit occurs, the device may be permanently damaged. Also, the utmost care should be taken for pattern designing and implementation of the device since it has power supply pins (VM, RS line, OUT line, and GND) through which a particularly large current may run. If these pins are wired incorrectly, an operation error may occur or the device may be destroyed.

The logic input pins must also be wired correctly. Otherwise, the device may be damaged owing to a current running through the IC that is larger than the specified current. Careful attention should be paid to design patterns and mountings.

## Input-Output equivalent circuit

Pin name	Input-Output signal	Input-Output equivalent circuit
DMODE0 DMODE1 DMODE2 CLK ENABLE RESET CW/CCW AGC0 AGC1 CLIM0	Logic input pin voltage  $GND \leq VIN1 (L) \leq 0.8 V$  $2.0 V \leq VIN1 (H) \leq 5.5 V$	
CLIM1  FLIM  BOOST	Multi state input pin voltage  $VCC, GND, VCC-100 k\Omega$ pull-up, or $GND-100 k\Omega$ pull-down (Resistance accuracy should be within $\pm 20 \%$ .)	
LTH	$100 k\Omega$ pull-down (Resistance accuracy should be within $\pm 20 \%$ .)	
LO1 LO2 MO	Logic output pin  $0 V \leq VOUT (L) \leq 0.5 V$  $4.75 V \leq VOUT (H) \leq 5.25 V$	
OSCM	OSCM frequency range  $0.64 MHz \leq f_{OSCM} \leq 2.4 MHz$	

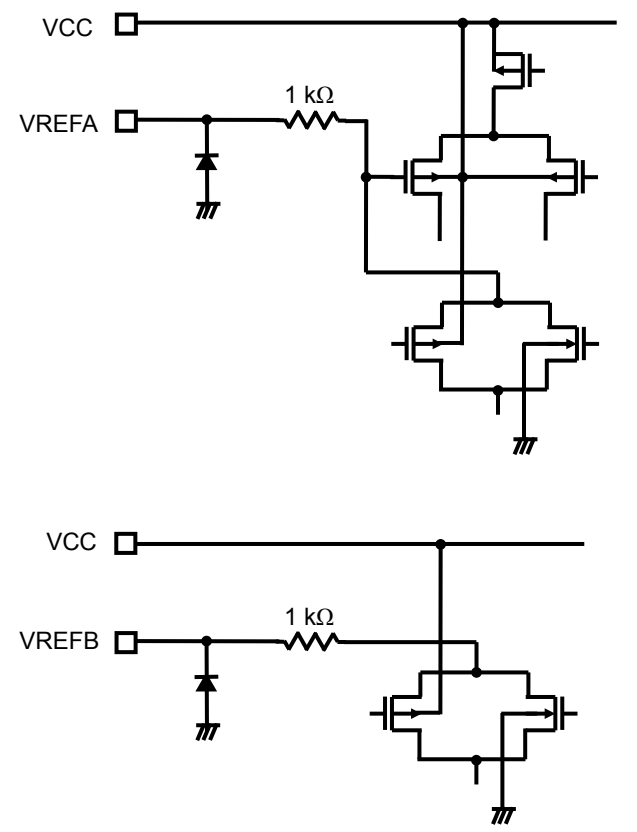
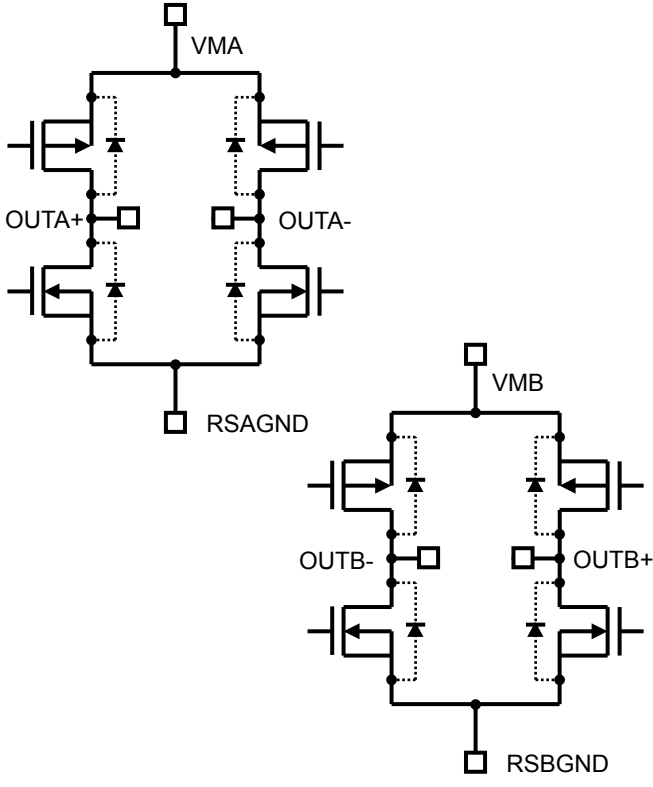
Pin name	Input-Output signal	Input-Output equivalent circuit
<p>VCC</p> <p>VREFA</p> <p>VREFB</p>	<p>VCC voltage range  <math>4.75\text{ V} \leq VCC \leq 5.25\text{ V}</math></p> <p>VREF input voltage range  <math>GND \leq VREF \leq 3.6\text{ V}</math></p>	
<p>VMA</p> <p>VMB</p> <p>OUT A+</p> <p>OUT A-</p> <p>OUT B+</p> <p>OUT B-</p> <p>RSAGND</p> <p>RSBGND</p>	<p>VM operation voltage range  <math>10\text{ V} \leq VM \leq 47\text{ V}</math></p> <p>Output pin voltage range  <math>10\text{ V} \leq VM \leq 47\text{ V}</math></p>	

Note: The equivalent circuit diagrams may be simplified or omitted for explanatory purposes.

### ◆Basic function of stepping motor control

#### 1. CLK function

Each up-edge of the CLK signal shifts the current step and electrical angle of the motor.

Note: Analog filter of 200 ns ( $\pm 20\%$ ) is adopted to CLK pin in the IC

CLK	Function
↑	Shifts the electrical angle and current step per each up-edge.
↓	— (no change, maintain former state)

#### 2. ENABLE function

The ENABLE pin controls the ON and OFF of the stepping motor outputs. Motor operation is started by switching ON and stopped by switching OFF. (In the state of OFF, all of the output MOSFET are turned off and become high impedance state (Hi-Z).) It is recommended to set the ENABLE pin to Low during VM power-on and power-off sequence to avoid any motor operation when VM voltage is below the operation range. And so, switching the ENABLE pin to High after VM voltage is stabilized as the actually used voltage is recommended.

ENABLE	Function
High	Motor outputs: ON (Normal operation)
Low	Motor outputs: OFF (Hi-Z)

#### 3. CW/CCW function / Output pin function (output logic at charge starting)

The CW/CCW pin controls the rotation direction of the stepping motor. When CW/CCW is set to High, OUT (+) outputs high and OUT (-) outputs low in Charge starting. When CW/CCW is set to Low, OUT (+) outputs Low and OUT (-) outputs High in Charge starting.

CW/CCW	Function
High (CW)	Clock-wise: The current of Ach leads the current of Bch by 90-degree phase difference.
Low (CCW)	Counter clock-wise: The current of Bch leads the current of Ach by 90-degree phase difference.

#### 4. DMODE (step resolution setting) function

The DMODE pins are used to set the step resolution for stepping motor operation. If all 3 pins (DMODE0, 1, and 2) are set to Low, the device goes into 'standby mode'. During 'standby mode', few internal circuits are fully shutdown to reduce power dissipation. If any of the 3 pins (DMODE0, 1, or 2) is set to High, the TB67S249FTG will reboot from standby mode. However, it will take 7.5  $\mu\text{s}$  (typ.) to stabilize the internal circuit. Therefore, please wait for this warm-up period and input signals to boot up.

Note: Built-in digital filter of 1.25  $\mu\text{s}$  ( $\pm 20\%$ ) is adopted to DMODE pins.

Note: Built-in digital filter of 0.94  $\mu\text{s}$  ( $\pm 20\%$ ) is adopted to DMODE pins for standby mode.

DMODE0	DMODE1	DMODE2	Function
High	High	High	1/32 step resolution
High	High	Low	1/16 step resolution
High	Low	High	1/8 step resolution
High	Low	Low	1/2 (b) step resolution
Low	High	High	1/4 step resolution
Low	High	Low	1/2 (a) step resolution
Low	Low	High	1/1 step resolution
Low	Low	Low	Standby mode (Internal oscillator circuit (OSCM) and output MOSFETs are set to 'OFF')

DMODE0, 1, and 2 pins can be switched during operation. For the following step, the current of the nearest electric angle before or after switching will flow. Please refer to the application note for detailed functions.

## 5. RESET function

The RESET pin initializes the internal electrical angle.

Note: Built-in digital filter of 0.625  $\mu$ s ( $\pm$ 20 %) is adopted to RESET pin.

RESET	Function
High	Initializes the internal electrical angle
Low	Normal operation

When the RESET pin is set to High, the current setting for each H-bridge (Ach and Bch) will be set to the value below. Also, the MO pin outputs Low level when the electrical angle corresponds to the initial value.

Step resolution	Ach current	Bch current	Electrical angle
1/32 step setting	71 %	71 %	45°
1/16 step setting	71 %	71 %	45°
1/8 step setting	71 %	71 %	45°
1/2 (b) step setting	71 %	71 %	45°
1/4 step setting	71 %	71 %	45°
1/2 (a) step setting	100 %	100 %	45°
1/1 step setting	100 %	100 %	45°

## 6. MO (Monitor output: electrical angle monitor) function

MO pin outputs an internal initial electrical angle as a signal. The MO is an open drain type pin; therefore to use the function properly, please pull up the MO output to VCC. (The pull-up resistor value should be set between 10 k $\Omega$  and 100 k $\Omega$ .) The pin level is high impedance (Hi-Z) during the normal operation (internal MOSFET is turned off and pin voltage is VCC). And when the internal electrical angle is equal to the initial angle, the pin level will be Low (internal MOSFET is turned ON) as shown below.

MO	Function
VCC (Hi-Z)	Electrical angle is not at the initial position
Low	Electrical angle is at the initial position

Note: Hi-Z: High impedance state

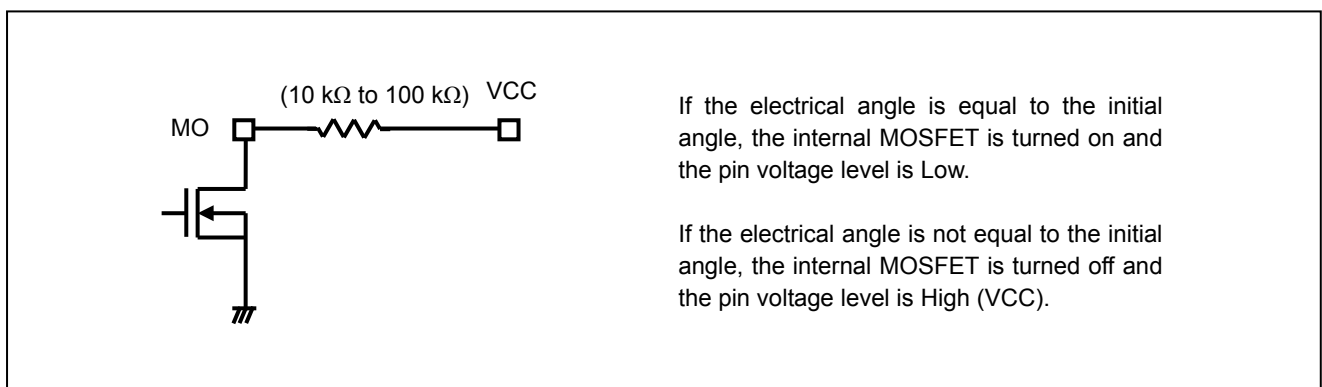

Note: The equivalent circuit diagrams may be simplified or some parts of them may be omitted for explanatory purposes.



## Step resolution and set current (Electric angle: 0 to 180°)

Electrical angle	STEP	IOUTA(%)	IOUTB(%)	1/32 step	1/16 step	1/8 step	1/4 step	1/2(b) step	1/2(a) step	1/1 step
0°	1	+100	0	✓	✓	✓	✓	✓	✓	
	2	+100	+5	✓						
	3	+100	+10	✓	✓					
	4	+99	+15	✓						
	5	+98	+20	✓	✓	✓				
	6	+97	+25	✓						
	7	+96	+29	✓	✓					
	8	+94	+34	✓						
	9	+92	+38	✓	✓	✓	(Note2)			
	10	+90	+43	✓						
	11	+88	+47	✓	✓					
	12	+86	+52	✓						
	13	+83	+56	✓	✓	✓				
	14	+80	+60	✓						
	15	+77	+63	✓	✓					
	16	+74	+67	✓						
45°	17	+71	+71	✓	✓	✓	✓	✓	(Note1)	(Note1)
	18	+67	+74	✓						
	19	+63	+77	✓	✓					
	20	+60	+80	✓						
	21	+56	+83	✓	✓	✓				
	22	+52	+86	✓						
	23	+47	+88	✓	✓					
	24	+43	+90	✓						
	25	+38	+92	✓	✓	✓	(Note2)			
	26	+34	+94	✓						
	27	+29	+96	✓	✓					
	28	+25	+97	✓						
	29	+20	+98	✓	✓	✓				
	30	+15	+99	✓						
	31	+10	+100	✓	✓					
	32	+5	+100	✓						
90°	33	0	+100	✓	✓	✓	✓	✓	✓	
	34	-5	+100	✓						
	35	-10	+100	✓	✓					
	36	-15	+99	✓						
	37	-20	+98	✓	✓	✓				
	38	-25	+97	✓						
	39	-29	+96	✓	✓					
	40	-34	+94	✓						
	41	-38	+92	✓	✓	✓	(Note2)			
	42	-43	+90	✓						
	43	-47	+88	✓	✓					
	44	-52	+86	✓						
	45	-56	+83	✓	✓	✓				
	46	-60	+80	✓						
	47	-63	+77	✓	✓					
	48	-67	+74	✓						
135°	49	-71	+71	✓	✓	✓	✓	✓	(Note1)	(Note1)
	50	-74	+67	✓						
	51	-77	+63	✓	✓					
	52	-80	+60	✓						
	53	-83	+56	✓	✓	✓				
	54	-86	+52	✓						
	55	-88	+47	✓	✓					
	56	-90	+43	✓						
	57	-92	+38	✓	✓	✓	(Note2)			
	58	-94	+34	✓						
	59	-96	+29	✓	✓					
	60	-97	+25	✓						
	61	-98	+20	✓	✓	✓				
	62	-99	+15	✓						
	63	-100	+10	✓	✓					
	64	-100	+5	✓						
180°	65	-100	0	✓	✓	✓	✓	✓	✓	

Note1: 1/1 step and 1/2 (a) step: Set current of 71 % corresponds to 100 %.

Note2: 1/4 step: Set current of 92 % corresponds to 100 %.

## Step resolution and set current (Electric angle: 180 to 360°)

Electrical angle	STEP	IOUTA(%)	IOUTB(%)	1/32 step	1/16 step	1/8 step	1/4 step	1/2(b) step	1/2(a) step	1/1 step
180°	65	-100	0	✓	✓	✓	✓	✓	✓	
	66	-100	-5	✓						
	67	-100	-10	✓	✓					
	68	-99	-15	✓						
	69	-98	-20	✓	✓	✓				
	70	-97	-25	✓						
	71	-96	-29	✓	✓					
	72	-94	-34	✓						
	73	-92	-38	✓	✓	✓	(Note2)			
	74	-90	-43	✓						
	75	-88	-47	✓	✓					
	76	-86	-52	✓						
	77	-83	-56	✓	✓	✓				
	78	-80	-60	✓						
79	-77	-63	✓	✓						
80	-74	-67	✓							
225°	81	-71	-71	✓	✓	✓	✓	✓	(Note1)	(Note1)
	82	-67	-74	✓						
	83	-63	-77	✓	✓					
	84	-60	-80	✓						
	85	-56	-83	✓	✓	✓				
	86	-52	-86	✓						
	87	-47	-88	✓	✓					
	88	-43	-90	✓						
	89	-38	-92	✓	✓	✓	(Note2)			
	90	-34	-94	✓						
	91	-29	-96	✓	✓					
	92	-25	-97	✓						
	93	-20	-98	✓	✓	✓				
	94	-15	-99	✓						
95	-10	-100	✓	✓						
96	-5	-100	✓							
270°	97	0	-100	✓	✓	✓	✓	✓	✓	
	98	+5	-100	✓						
	99	+10	-100	✓	✓					
	100	+15	-99	✓						
	101	+20	-98	✓	✓	✓				
	102	+25	-97	✓						
	103	+29	-96	✓	✓					
	104	+34	-94	✓						
	105	+38	-92	✓	✓	✓	(Note2)			
	106	+43	-90	✓						
	107	+47	-88	✓	✓					
	108	+52	-86	✓						
	109	+56	-83	✓	✓	✓				
	110	+60	-80	✓						
111	+63	-77	✓	✓						
112	+67	-74	✓							
315°	113	+71	-71	✓	✓	✓	✓	✓	(Note1)	(Note1)
	114	+74	-67	✓						
	115	+77	-63	✓	✓					
	116	+80	-60	✓						
	117	+83	-56	✓	✓	✓				
	118	+86	-52	✓						
	119	+88	-47	✓	✓					
	120	+90	-43	✓						
	121	+92	-38	✓	✓	✓	(Note2)			
	122	+94	-34	✓						
	123	+96	-29	✓	✓					
	124	+97	-25	✓						
	125	+98	-20	✓	✓	✓				
	126	+99	-15	✓						
127	+100	-10	✓	✓						
128	+100	-5	✓							
360°	(129)	+100	0	✓	✓	✓	✓	✓	✓	

Note1: 1/1 step and 1/2 (a) step: Set current of 71 % corresponds to 100 %.

Note2 1/4 step: Set current of 92 % corresponds to 100 %.

### 7. LO1, LO2 (Error Output: error detect flag output) function

The LO1 and LO2 are signals that are flagged when the error state is detected. Both pins are open drain type, therefore to use the function properly; the LO1 and LO2 pins should be pulled up to the VCC. (Set the pull-up resistor in the range of 10k to 100k $\Omega$ .) During normal operation, the pin is high-impedance (Internal MOSFET is turned off and the pin voltage is VCC). Once the error detect function (thermal shutdown (TSD), over current protection (ISD), or motor load open (OPD)) operates, the pins will output Low level (Internal MOSFET is turned ON) as follows.

Reasserting the VM power or using the standby mode to release the error detection status, the LO1 and LO2 pins will show "normal operation" status again. If function of LO1 or LO2 is not used, leave the pins open.

LO1	LO2	Function
VCC (Hi-Z)	VCC (Hi-Z)	Normal status (Normal operation)
VCC (Hi-Z)	Low	Detected motor load open (OPD)
Low	VCC (Hi-Z)	Detected over current (ISD)
Low	Low	Detected over thermal (TSD)

Note: Hi-Z: High impedance state

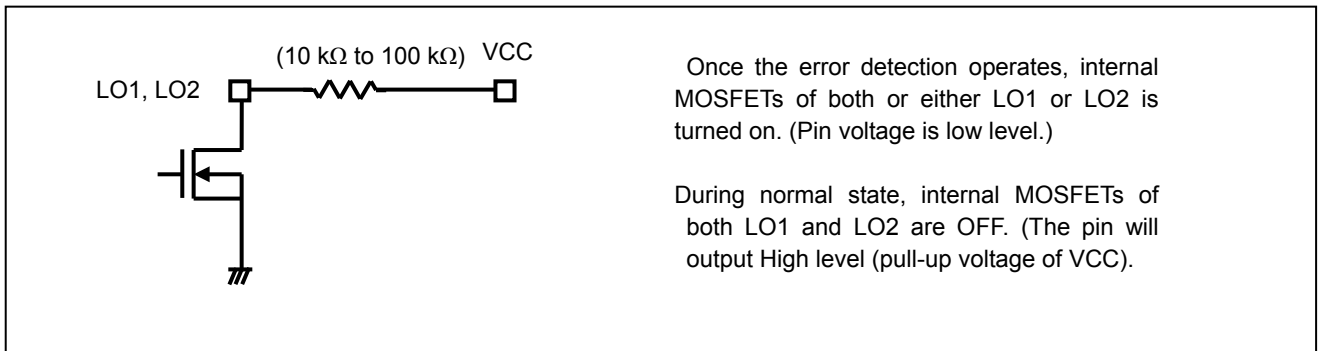

Note: The equivalent circuit diagrams may be simplified or omitted for explanatory purposes.

### 8. OSCM (internal oscillator) function

OSCM is used to set the internal oscillator frequency for constant current PWM control. The values of the resistor and the capacitor connected to this pin will set the OSCM frequency. Please connect the pull-up resistor to the VCC when PWM frequency is set by the external components. Also, to use an internal 'fixed value OSCM frequency' (not using any external components), disconnect the ROSC resistor and short the OSCM pin to the GND. Note that when using the internal 'fixed value OSCM frequency', do not input any control signal for 20  $\mu$ s (typ.) after power on or standby release. (It takes 20  $\mu$ s to judge the existence of the external components and switch to the 'fixed value OSCM frequency' mode.) The 'fixed value OSCM frequency' will be around 0.92 MHz, so the fchop will be around 57 kHz.

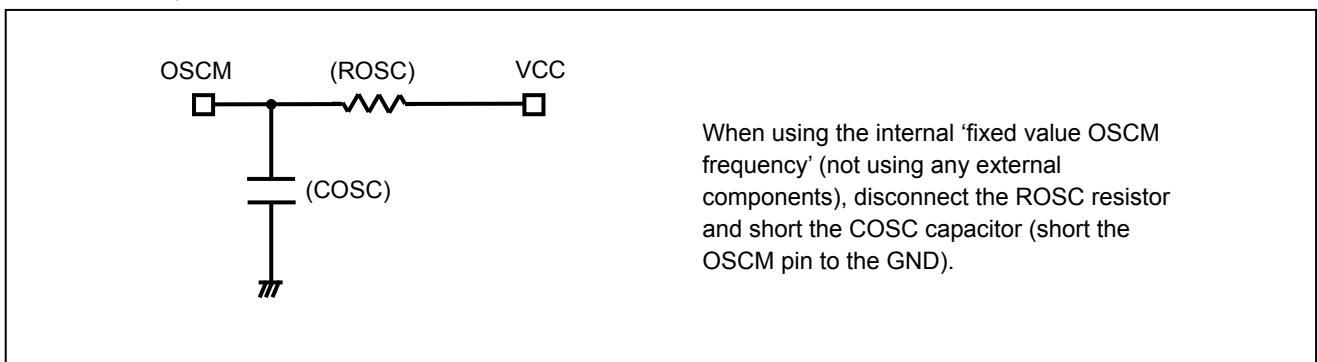

Note: The equivalent circuit diagrams may be simplified or omitted for explanatory purposes.

Note: The oscillator frequency can be adjusted by controlling the values of resistor (ROSC) and capacitor (COSC). When conforming the frequency, it is recommended to fix the capacitor to 270 pF and change the ROSC value. For details, please refer to the following descriptions.

---

**OSCM oscillator frequency (chopping frequency) calculation**

OSCM oscillator frequency can be calculated by using the external component values (ROSC and COSC), and the formula is shown below. (COSC is fixed to 270 pF.)

$$\underline{f_{OSCM} = 4.0 \times ROSC^{(-0.8)}}$$

COSC and ROSC are external components to set the oscillator frequency. When adjusting the oscillator frequency with components, it is recommended to fix COSC to 270 pF and change the constant number of ROSC.

Moreover, the relation between the chopping frequency for constant current PWM ( $f_{chop}$ ) and the OSCM oscillator frequency ( $f_{OSCM}$ ) is as follows;

$$\underline{f_{chop} = f_{OSCM} / 16}$$

For normal operation, setting the frequency in the range of 50 kHz to 70 kHz and adjusting suitably as needed is recommended

When the chopping frequency is set high, the current ripple will be smaller, which will lead to a higher reproducibility of a waveform. However, the chopping frequency per unit time is increased and so the gate loss and the switching loss of the integrated MOSFET will be larger, which will lead to an additional heat generation. On the other hand, when the chopping frequency is set low, the current ripple will be larger but the heat generation is reduced. Please set the frequency according to the usage conditions and environment.

## ◆Stepping motor application features (anti-stall, sense resistor less PWM)

### 9. Active Gain Control (Anti-stall) function

AGC0, AGC1 pins control the Active Gain Control to turn on or off. When both pins are set to High, the AGC is turned on. The PWM current threshold will be reduced in a phased manner where the upper limited current is determined by VREF. When both pins are set to Low, the AGC is turned off and the current, which is set by VREF, flows.

Note: Built-in digital filter of 0.625 μs (±20%) is adopted to AGC0 and AGC1 pins.

AGC0	AGC1	Function
High	High	AGC: ON
High	Low	(Note1)
Low	Low	AGC: OFF

Normally, set these pins as follows; AGC0, AGC1= (High, High) or (Low, Low). Please do not switch the AGC0 pin level during operation.

Note1: Use this configuration when switching ON or OFF of AGC during operation. As for concrete usage method, refer to the application note.

### 10. CLIM (AGC bottom current limit) function

The CLIM0 and CLIM1 pins set the bottom current limit of the AGC. When AGC is active, the PWM current threshold will be reduced in a phased manner. By using the CLIM function, the motor current will not go below the bottom limit. The CLIM0 is a 2 stated logic input, and the CLIM1 is a 4 stated logic input.

Note: Built-in digital filter of 0.625 μs (±20%) is adopted to CLIM0 and CLIM1 pins.

CLIM0	CLIM1	Function
High	VCC short	AGC bottom current limit: IOU x 80 %
	VCC-100 kΩ pull-up	AGC bottom current limit: IOU x 75 %
	GND-100 kΩ pull-down	AGC bottom current limit: IOU x 70 %
	GND short	AGC bottom current limit: IOU x 65 %
Low	VCC short	AGC bottom current limit: IOU x 60 %
	VCC-100 kΩ pull-up	AGC bottom current limit: IOU x 55 %
	GND-100 kΩ pull-down	AGC bottom current limit: IOU x 50 %
	GND short	AGC bottom current limit: IOU x 45 %

Note: Resistance accuracy should be within ±20 %.

### 11. BOOST (current boost) function

The BOOST pin sets the current boost level when the load torque is increased. When AGC is turned on, the PWM current threshold will be reduced in a phased manner. However, once the load torque is increased, the device will then boost the PWM current threshold to prevent the motor from stalling. The BOOST pin is a 4 stated logic input pin.

Note: Built-in digital filter of 0.625 μs (±20%) is adopted to BOOST pin.

BOOST	Function
VCC short	Takes 5 steps maximum to reach 100 % current (design value)
VCC-100 kΩ pull-up	Takes 7 steps maximum to reach 100 % current (design value)
GND-100 kΩ pull-down	Takes 9 steps maximum to reach 100 % current (design value)
GND short	Takes 11 steps maximum to reach 100 % current (design value)

Note: Resistance accuracy should be within ±20 %.

Note: Current boost step is largest when BOOST is shorted to VCC, and smallest when shorted to the GND.

## 12. FLIM (AGC Frequency limit) function

The FLIM pin sets the bottom frequency limit for the AGC to be active. It can reduce the resonance frequency of the motor start in using AGC. The FLIM pin is a 4 stated logic input.

Note: Built-in digital filter of 0.625  $\mu$ s ( $\pm$ 20%) is adopted to FLIM pin.

FLIM	Function
VCC short	Frequency limit: ON, AGC is invalid when fCLK is below 675 Hz
VCC-100 k $\Omega$ pull-up	Frequency limit: ON, AGC is invalid when fCLK is below 450 Hz
GND-100 k $\Omega$ pull-down	Frequency limit: ON, AGC is invalid when fCLK is below 225 Hz
GND short	FLIM: OFF

Note: Resistance accuracy should be within  $\pm$ 20%.

The frequency in the table above is in the case of full step resolution. Frequency limit threshold depends on the step resolution setting.

FLIM	1/1	1/2 (a)	1/2 (b)	1/4	1/8	1/16	1/32
VCC short	675 Hz	1.35 kHz	1.35 kHz	2.7 kHz	5.4 kHz	10.8 kHz	21.6 kHz
VCC-100 k $\Omega$ pull-up	450 Hz	900 Hz	900 Hz	1.8 kHz	3.6 kHz	7.2 kHz	14.4 kHz
GND-100 k $\Omega$ pull-down	225 Hz	450 Hz	450 Hz	900 Hz	1.8 kHz	3.6 kHz	7.2 kHz
GND short	FLIM: OFF						

Note: Resistance accuracy should be within  $\pm$ 20%.

## 13. LTH (AGC detection threshold) function

The LTH pin sets the AGC detection threshold. Connect a 100 k $\Omega$  pull-down resistor to GND.

LTH	Function
GND-100 k $\Omega$ pull-down	Standard configuration for AGC detection threshold

Note: Resistance accuracy should be within  $\pm$ 20%.

**14. ADMD + ACDS (sense-resistor less PWM) control**

**ADMD (Advanced Dynamic Mixed Decay)**

The TB67S249FTG applied the ADMD architecture which monitors both charge and recirculating current during constant current PWM. The basic sequence of the ADMD is as shown below.

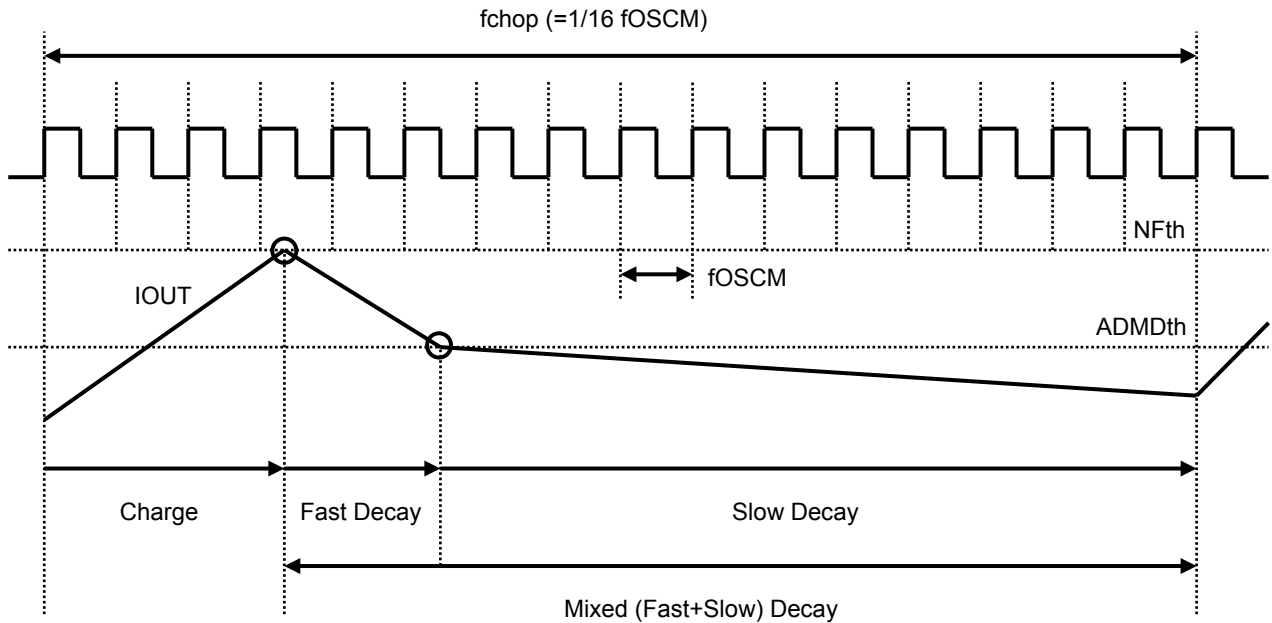

Timing charts may be simplified for explanatory purpose.

The basic constant current PWM sequence is a loop of Charge→Fast Decay→Slow Decay→Charge→... to keep the peak current below the threshold. The chopping frequency ( $f_{chop}$ ) is a period of 16 counts per cycle of OSCM oscillator frequency ( $f_{OSCM}$ ). The sequence of Charge, Fast Decay, and Slow Decay is switched within this  $f_{chop}$  cycle.

First, the motor current is charged (Charge sequence) until it reaches the constant current threshold ( $NF_{th}$ ), which is set by the VREF reference voltage. Once the motor current reaches the constant current threshold ( $NF_{th}$ ), a partial motor current recirculates back to the power supply (Fast Decay sequence). When the motor current reaches the fixed value ( $ADMD_{th}$ ) during recirculation; for the rest of the  $f_{chop}$  cycle, the motor is controlled to naturally discharge and hold the motor current as much as possible (Slow Decay sequence).

**Motor output MOSFET operation mode (Advanced Dynamic Mixed Decay)**

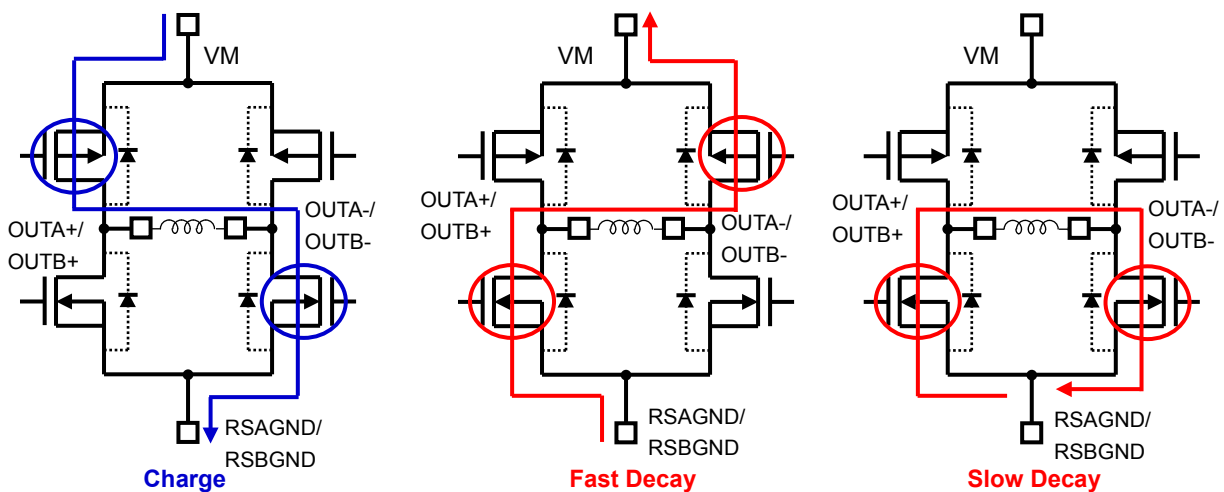

Note: Fixed value of 400 ns (design value) is prepared at the switching timing of MOSFET output to avoid any flow-through current. The equivalent circuit diagrams may be simplified or omitted for explanatory purposes.

## Constant current threshold calculation

The constant current PWM threshold can be set by applying voltage to the VREF pin.

$$I_{OUT} = V_{REF} \times 1.25$$

Example: When Current Ratio is 100 % and VREF voltage is 2.0 V, the constant current PWM threshold is calculated from following formula.

$$I_{OUT} = 2.0 \times 1.25 = 2.5 \text{ A}$$

## ADMD current waveform

- When the next current step/ratio is higher than the previous step

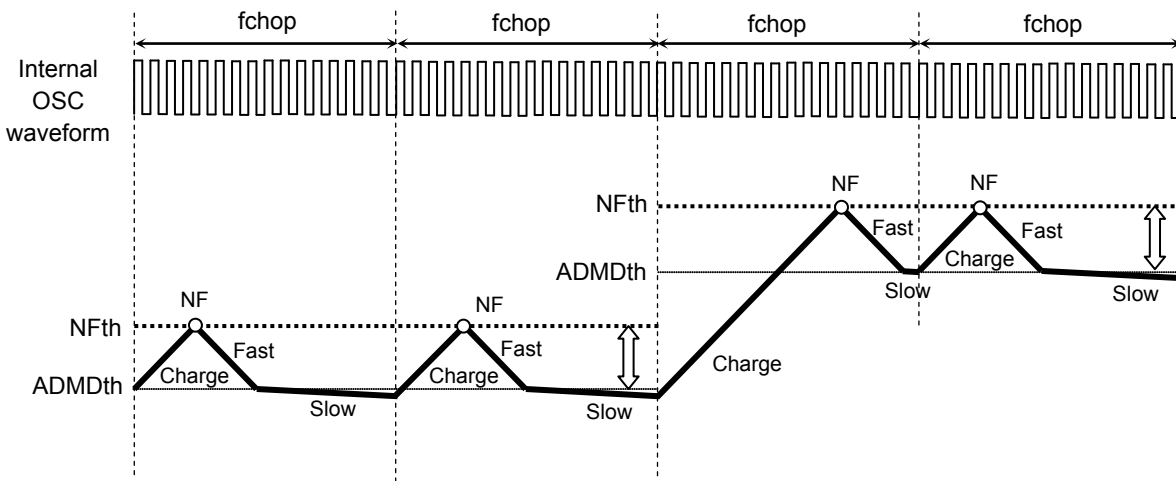

- When the Charge period continues beyond 1 fchop cycle

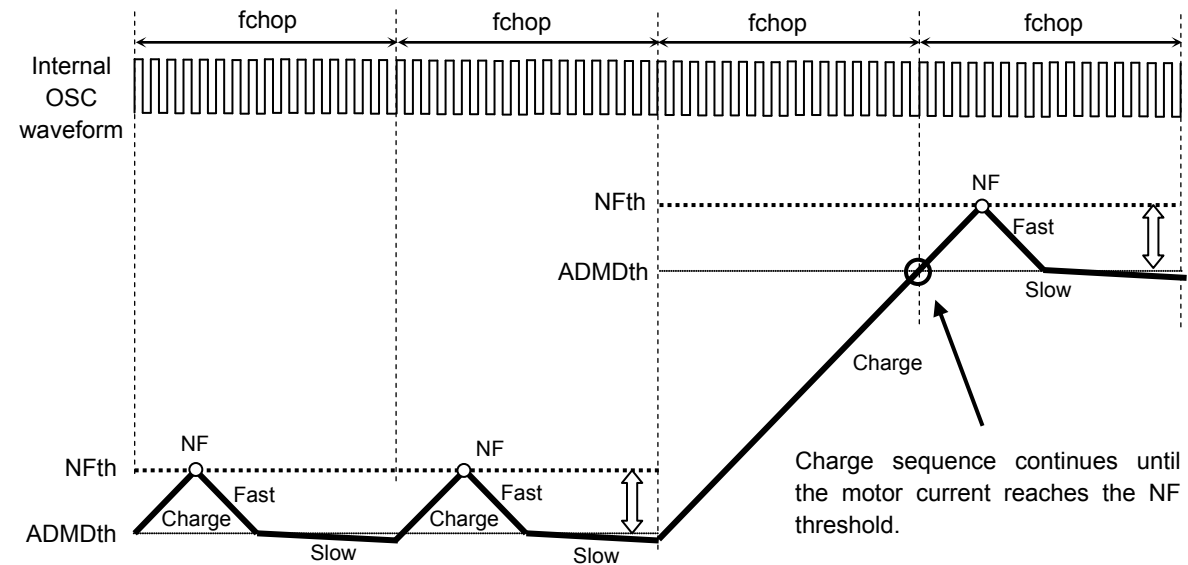

Timing charts may be simplified for explanatory purpose.



- When the next current step/ratio is lower than the previous step

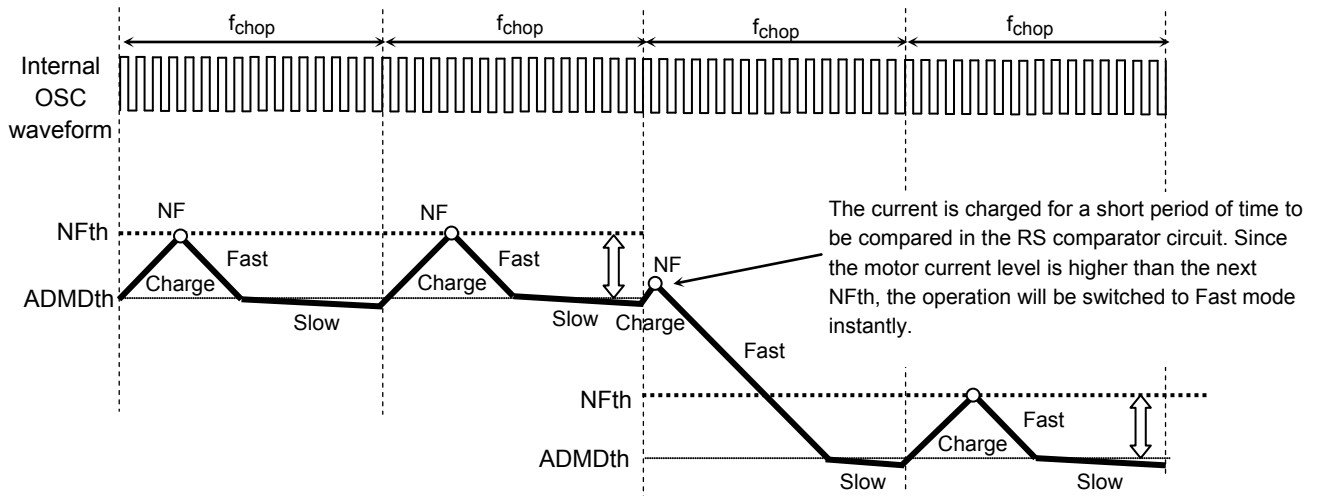

- When the Fast period continues beyond 1  $f_{chop}$  cycle (Current does not reach  $ADMDth$  within 1  $f_{chop}$  cycle.)

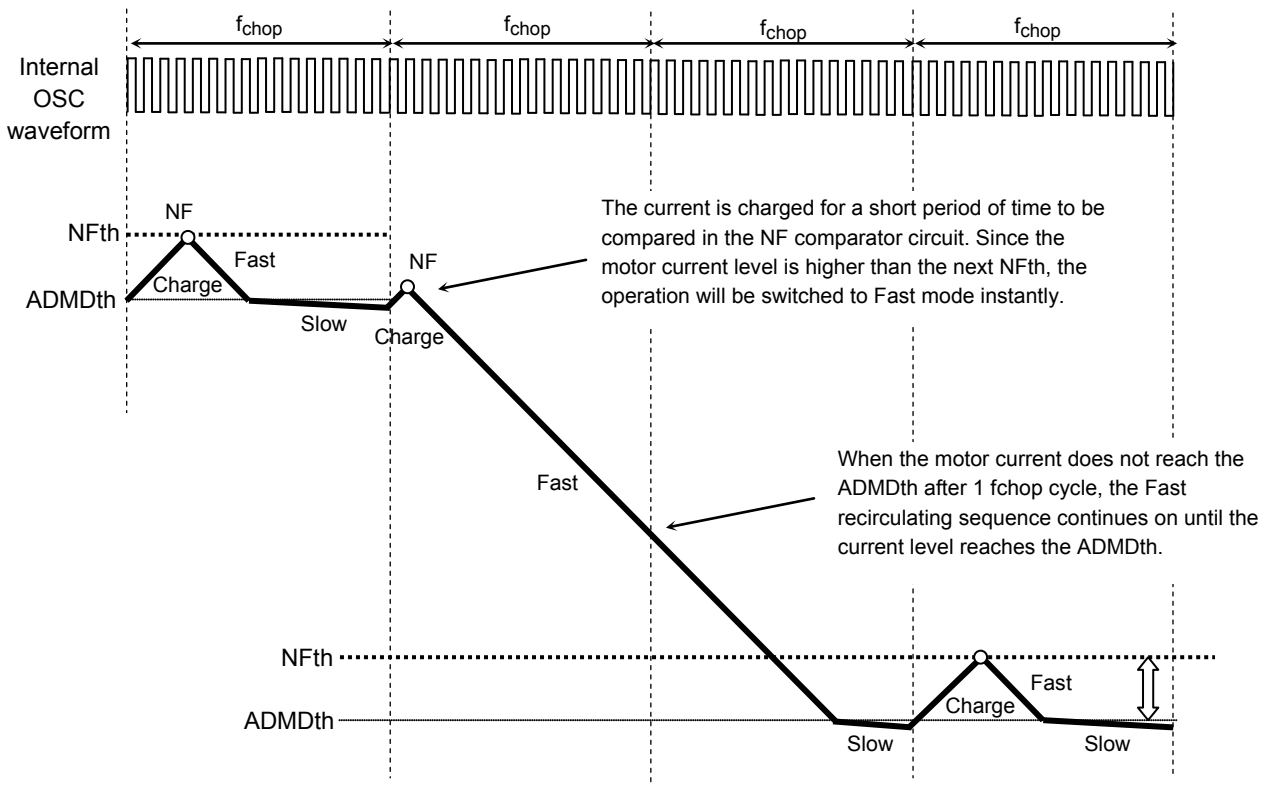

Timing charts may be simplified for explanatory purpose.

### Constant current PWM blank/mask time

The TB67S249FTG has multi filter time to reject incoming noise or spike (inrush) current, which is generated during motor operation, to avoid miss detection.

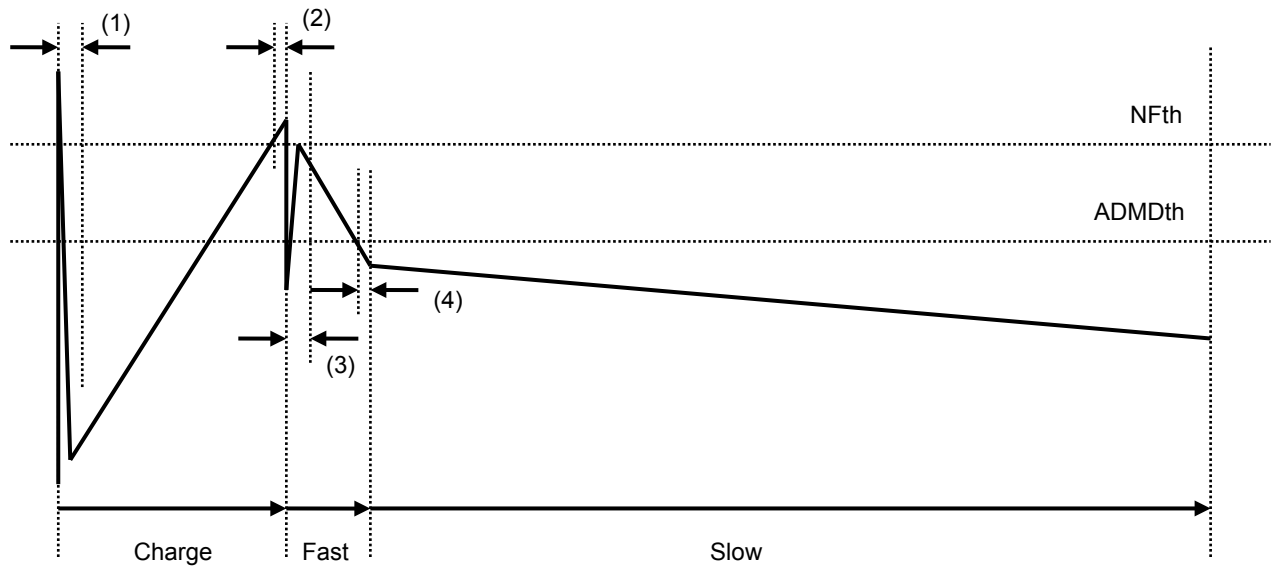

Timing charts may be simplified for explanatory purpose.

- (1) Digital NFblank (Filtering time to avoid spike current, which is generated before Charge): 1.25  $\mu\text{s}$  (typ.)
- (2) Analog NFblank (Filtering time to avoid pulse noise for NFth): 0.35  $\mu\text{s}$  (typ.)
- (3) Digital ADMDblank (Filtering time to avoid spike current, which is generated between Charge and Decay for ADMDth: 2.2  $\mu\text{s}$  (typ.)
- (4) Analog ADMDblank (Filtering time to avoid pulse noise for ADMDth): 0.35  $\mu\text{s}$  (typ.)

Note: Above periods are design values. They are not guaranteed.

### Absolute maximum ratings (Ta = 25°C)

Characteristics	Symbol	Rating	Unit	Remarks
Motor power supply	VM	50	V	—
Motor output voltage	VOUT	50	V	—
Motor output current	IOUT	4.5	A	(Note1)
Internal Logic power supply	VCC	6.0	V	—
Logic input voltage	VIN (H)	6.0	V	—
	VIN (L)	-0.4	V	—
MO output voltage	VMO	6.0	V	—
LO output voltage	VLO	6.0	V	—
MO Inflow current	IMO	6.0	mA	—
LO Inflow current	ILO	6.0	mA	—
Power dissipation	PD	1.3	W	(Note2)
Operating temperature	Topr	-20 to 85	°C	—
Storage temperature	Tstg	-55 to 150	°C	—
Junction temperature	Tj (max)	150	°C	—

Note1: For normal usage, the maximum current value should be determined by heat calculation.

The maximum output current may be further limited depending on ambient temperature and board conditions (heat conditions).

Note2: Device alone (Ta =25°C)

Ta: Ambient temperature

Topr: Ambient temperature while the IC is active

Tj: Junction temperature while the IC is active. Tj (max) is limited by the thermal shutdown (TSD) threshold.

Please set the usage conditions so that the peak Tj is kept under 120°C for indication.

### Caution) Absolute maximum ratings

The absolute maximum ratings of a semiconductor device are a set of ratings that must not be exceeded, even for a moment. Do not exceed any of these ratings. Exceeding the rating (s) may cause device breakdown, damage or deterioration, and may result in injury by explosion or combustion. The value of even one parameter of the absolute maximum ratings should not be exceeded under any circumstances. All voltage ratings, including supply voltages, must always be followed. Other notes and considerations described in the datasheet should also be referred to.

### Operation ranges (Ta=-20 to 85°C)

Characteristics	Symbol	Min	Typ.	Max	Unit	Remarks
Motor power supply	VM	10	24	47	V	—
Motor output current	IOUT	—	2.25	4.5	A	(Note1)
MO output pin voltage	VMO	—	3.3	VCC	V	Pull-up voltage
LO output pin voltage	VLO	—	3.3	VCC	V	Pull-up voltage
Clock input frequency	fCLK	—	—	1000	kHz	(Note2)
Chopping frequency	Fchop (range)	40	70	150	kHz	—
VREF input voltage	VREF	GND	2.0	3.6	V	—

Note1: The actual maximum current may be limited due to operating circumstances (operating conditions of step resolution, continuous operation time, etc. and thermal conditions of ambient temperature, PCB layout, etc.)

Note2: The actual maximum frequency may be limited due to operating circumstances (operating conditions of step resolution, continuous operation time, etc. and thermal conditions of ambient temperature, PCB layout, etc.)

### Electrical characteristics 1 (Ta = 25°C and VM = 24 V, unless otherwise specified)

Characteristics	Symbol	Test condition	Min	Typ.	Max	Unit	
Logic input voltage 1 (Except BOOST, CLIM1, and FLIM)	VIN1 (H)	High level	2.0	—	5.5	V	
	VIN1 (L)	Low level	0	—	0.8	V	
Logic input hysteresis voltage	VIN (HYS)	Hysteresis voltage	0.1	—	0.3	V	
Logic input voltage 2 (BOOST, CLIM1, and FLIM)	VIN2 (H)	VCC short	4.2	—	VCC	V	
	VIN2 (PU)	VCC-100 kΩ pull-up	2.8	—	3.55	V	
	VIN2 (PD)	GND-100 kΩ pull-down	1.45	—	2.2	V	
	VIN2 (L)	GND short	0	—	0.8	V	
Logic input current 1 (Except BOOST, CLIM1, and FLIM)	IIN1 (H)	Input voltage=3.3 V	—	33	—	μA	
	IIN1 (L)	Input voltage=0 V	—	—	1	μA	
MO output pin voltage	VOL (MO)	IOL=5 mA LO=Low	—	0.2	0.5	V	
LO output pin voltage	VOL (LO)	IOL=5 mA LO=Low	—	0.2	0.5	V	
Current consumption	IM1	Standby mode	—	2	—	mA	
	IM2	OUT: OPEN, ENABLE: Low, Standby mode: Release	3	5	7	mA	
	IM3	OUT: OPEN, ENABLE: High, Standby mode: Release	4	6	8	mA	
Output leakage current	High-side	IOH	VM=50 V, VOUT=0 V	—	—	1	μA
	Low-side	IOL	VM=VOUT=50 V	1	—	—	μA
Motor current channel differential	ΔIOUT1	Current differential between channels	-5	0	5	%	
Motor current setting differential	ΔIOUT2	IOUT=1.5 A	-5	0	5	%	
Motor output ON-resistance ( High-side + Low-side)	Ron (H+L)	Tj=25°C, Forward direction (High + Low side)	—	0.33	0.45	Ω	

Note: VIN (H) is defined as the VIN voltage that causes the outputs (OUTA+, OUTA-, OUTB+ and OUTB-) to change when a pin under test is gradually raised from 0 V. VIN (L) is defined as the VIN voltage that causes the outputs (OUTA+, OUTA-, OUTB+ and OUTB-) to change when the pin is then gradually lowered. The difference between VIN (H) and VIN (L) is defined as the VIN (HYS).

### Electrical characteristics 2 (Ta = 25°C and VM = 24 V, unless otherwise specified)

Characteristics	Symbol	Test condition	Min	Typ.	Max	Unit
VREF input current	IREF	VREF=2.0 V	—	0	1	μA
VCC voltage	VCC	ICC=5.0 mA	4.75	5.0	5.25	V
VCC current	ICC	VCC=5.0 V	—	2.5	5.0	mA
VREF gain	VREF (gain)	VREF=2.0 V	—	1.25	—	A/V
Thermal shutdown (TSD) threshold (Note1)	T <sub>J</sub> TSD	—	145	160	175	°C
VM power-on-reset threshold	VMPOR (H)	POR release	6.5	7.5	8.5	V
	VMPOR (L)	POR detect	6.0	7.0	8.0	V
Over current protection (ISD) threshold (Not2)	ISD	—	5.0	6.0	7.0	A

#### Note 1: Thermal shutdown (TSD)

When the junction temperature of the IC reaches the specified value, the internal detection circuit operates to turn off the output block. The dead band time is provided in the IC to avoid the malfunction caused by switching and so on. While TSD works, the operation of the IC is in the standby mode. To release the shutdown circuit, apply the power supply again or configure the standby mode by DMODE pin. TSD function works when the IC is heated abnormally. Use the IC with the appropriate environment not to operate the TSD function often.

#### Note 2: Over current protection (ISD)

When the current, which exceeds the specified value, flows in the motor output, internal detection circuit operates and the operation of the output block is turned off. The dead band time is provided in the IC to avoid the malfunction caused by switching and so on. While ISD works, the operation of the IC is in the standby mode. To release the ISD protection, apply the power supply again or configure the standby mode by DMODE pin.

#### Back-EMF

While a motor is rotating, there is a timing at which power is fed back to the power supply. At that timing, the motor current recirculates back to the power supply due to the effect of the motor back-EMF.

If the power supply does not have enough sink capability, the power supply and output pins of the device might rise above the rated voltages. The magnitude of the motor back-EMF varies with usage conditions and motor characteristics. It must be fully verified that there is no risk that the TB67S249FTG or other components will be damaged or fail due to the motor back-EMF.

#### Cautions on Overcurrent Shutdown (ISD) and Thermal Shutdown (TSD)

The ISD and TSD circuits are only intended to provide temporary protection against irregular conditions such as an output short-circuit; they do not necessarily guarantee the complete IC safety.

If the device is used beyond the specified operating ranges, these circuits may not operate properly: then the device may be damaged due to an output short-circuit.

The ISD circuit is only intended to provide a temporary protection against an output short-circuit. If such a condition persists for a long time, the device may be damaged due to overstress. Overcurrent conditions must be removed immediately by external hardware.

#### IC Mounting

Do not insert devices incorrectly or in the wrong orientation. Otherwise, it may cause breakdown, damage and/or deterioration of the device.

### AC electrical characteristics (Ta = 25°C and VM = 24 V, unless otherwise specified)

Characteristics	Symbol	Test condition	Min	Typ.	Max	Unit
Minimum CLK 'High' pulse width	tCLK (H)	CLK (H) minimum pulse width	500	—	—	ns
Minimum CLK 'Low' pulse width	tCLK (L)	CLK (L) minimum pulse width	500	—	—	ns
Output MOSFET switching specifications	tr	—	60	110	160	ns
	tf	—	60	110	160	ns
	tpLH (CLK)	CLK to OUT	—	1000	—	ns
	tpHL (CLK)	CLK to OUT	—	1100	—	ns
OSCM oscillator accuracy	$\Delta f_{OSCM1}$	COSC=270 pF, ROOSC=5.1 k $\Omega$	-15	—	+15	%
	$\Delta f_{OSCM2}$	COSC: GND short, ROOSC: Open	-20	—	+20	%
PWM chopping frequency	fchop1	COSC=270 pF, ROOSC=5.1 k $\Omega$	—	67	—	kHz
	fchop2	COSC: GND short, ROOSC: Open	—	57	—	kHz

### AC characteristics timing chart

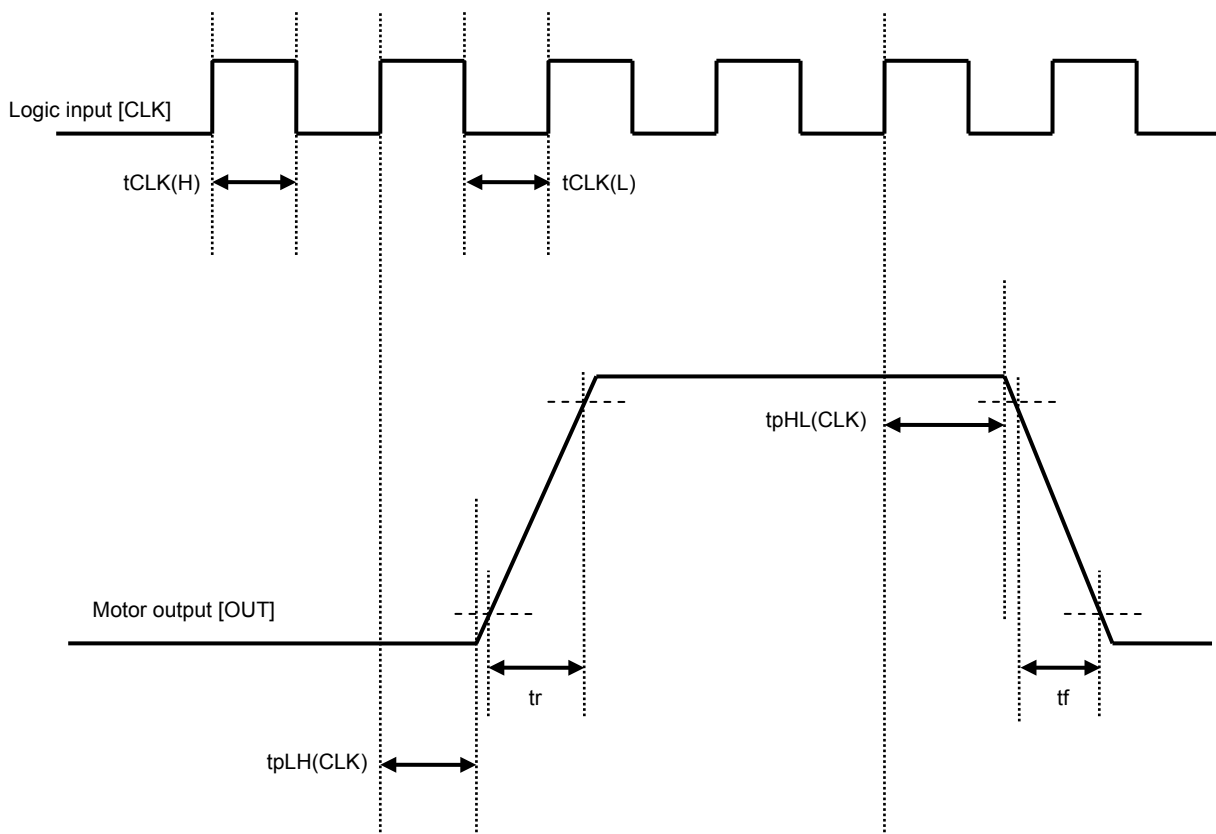

The timing chart may be simplified for explanatory purpose.

## Application circuit example

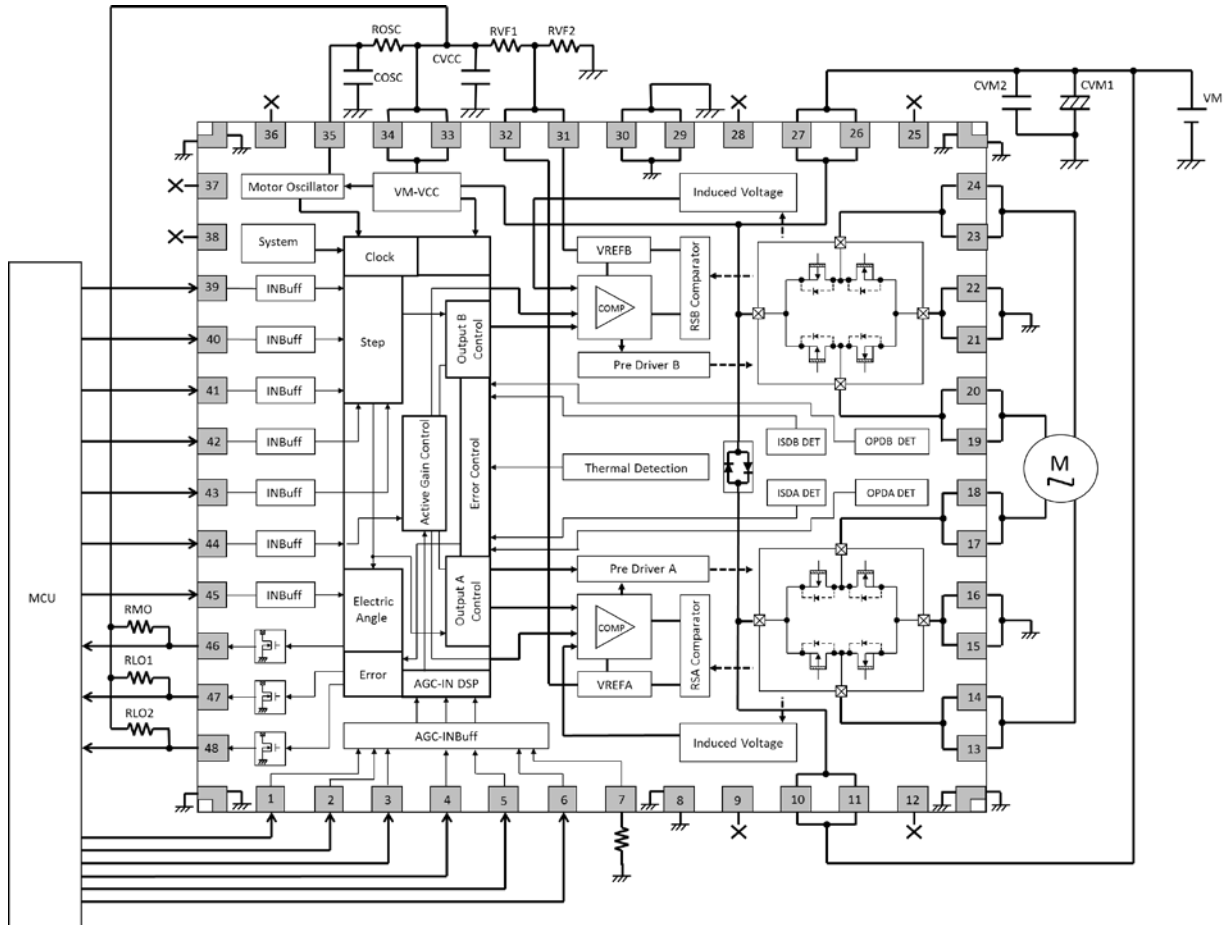

The application circuit shown in this document is provided for reference purposes only. The data for mass production are not guaranteed.

Constant numbers of components (for reference only)

Symbol	Component	Reference constant number
CVM1	Electrolytic capacitor	100 $\mu$ F (CVM1 $\geq$ 10 $\mu$ F)
CVM2	Ceramic capacitor	(0.1 $\mu$ F)
RVF1, RVF2	Resistor	Arbitrary (10 k $\Omega$ $\leq$ RVF1+RVF2 $\leq$ 50 k $\Omega$ )
CVCC	Ceramic capacitor	0.1 $\mu$ F
ROSC	Resistor	5.1 k $\Omega$ (1.8 k $\Omega$ to 8.2 k $\Omega$ )
COSC	Ceramic capacitor	270 pF
RMO	Resistor	10 k $\Omega$ (10 k $\Omega$ to 100 k $\Omega$ )
RLO1, RLO2	Resistor	10 k $\Omega$ (10 k $\Omega$ to 100 k $\Omega$ )

Constant numbers in above table are for reference only. Some components outside of the recommendation range can be adopted depending on the usage conditions.

Package dimensions (Unit: mm)

P-VQFN48-0707-0.50-004

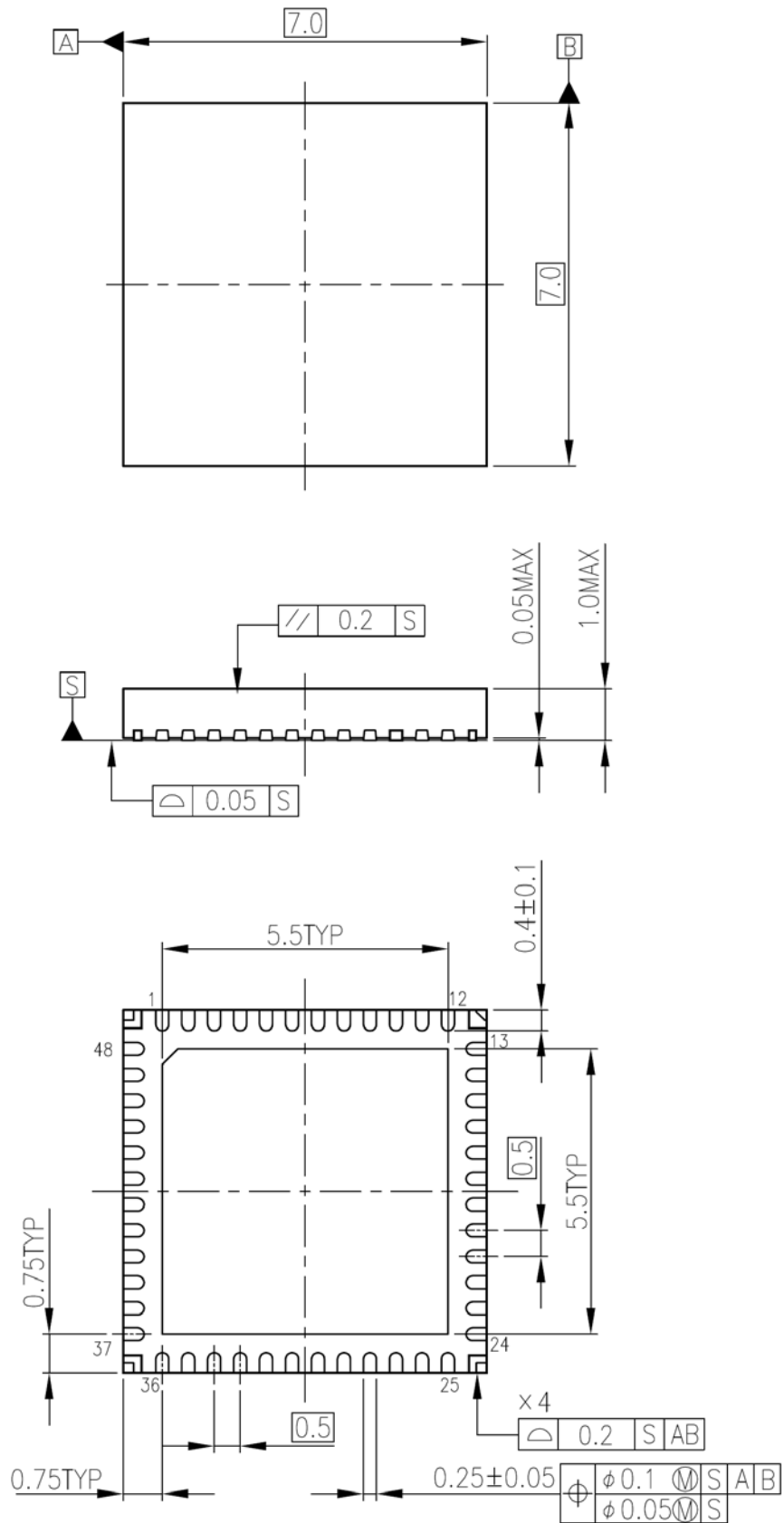

Weight 0.14 g (typ.)



## Notes on Contents

### 1. Block Diagrams

Some of the functional blocks, circuits, or constants in the block diagram may be omitted or simplified for explanatory purposes.

### 2. Equivalent Circuits

The equivalent circuit diagrams may be simplified or some parts of them may be omitted for explanatory purposes.

### 3. Timing Charts

Timing charts may be simplified for explanatory purposes.

### 4. Application Circuits

The application circuits shown in this document are provided for reference purposes only. Thorough evaluation is required, especially at the mass production design stage.

Providing these application circuit examples does not grant a license for industrial property rights.

## IC Usage Considerations

### Notes on handling of ICs

- [1] The absolute maximum ratings of a semiconductor device are a set of ratings that must not be exceeded, even for a moment. Do not exceed any of these ratings.  
Exceeding the rating(s) may cause the device breakdown, damage or deterioration, and may result injury by explosion or combustion.
- [2] Use an appropriate power supply fuse to ensure that a large current does not continuously flow in case of over current and/or IC failure. The IC will fully break down when used under conditions that exceed its absolute maximum ratings, when the wiring is routed improperly or when an abnormal pulse noise occurs from the wiring or load, causing a large current to continuously flow and the breakdown can lead smoke or ignition. To minimize the effects of the flow of a large current in case of breakdown, appropriate settings, such as fuse capacity, fusing time and insertion circuit location, are required.
- [3] If your design includes an inductive load such as a motor coil, incorporate a protection circuit into the design to prevent device malfunction or breakdown caused by the current resulting from the inrush current at power ON or the negative current resulting from the back electromotive force at power OFF. IC breakdown may cause injury, smoke or ignition.  
Use a stable power supply with ICs with built-in protection functions. If the power supply is unstable, the protection function may not operate, causing IC breakdown. IC breakdown may cause injury, smoke or ignition.
- [4] Do not insert devices in the wrong orientation or incorrectly.  
Make sure that the positive and negative terminals of power supplies are connected properly.  
Otherwise, the current or power consumption may exceed the absolute maximum rating, and exceeding the rating(s) may cause the device breakdown, damage or deterioration, and may result injury by explosion or combustion.  
In addition, do not use any device that is applied the current with inserting in the wrong orientation or incorrectly even just one time.
- [5] Carefully select external components (such as inputs and negative feedback capacitors) and load components (such as speakers), for example, power amp and regulator.  
If there is a large amount of leakage current such as input or negative feedback condenser, the IC output DC voltage will increase. If this output voltage is connected to a speaker with low input withstand voltage, overcurrent or IC failure can cause smoke or ignition. (The over current can cause smoke or ignition from the IC itself.) In particular, please pay attention when using a Bridge Tied Load (BTL) connection type IC that inputs output DC voltage to a speaker directly.

---

**Points to remember on handling of ICs****(1) Over current Protection Circuit**

Over current protection circuits (referred to as current limiter circuits) do not necessarily protect ICs under all circumstances. If the over current protection circuits operate against the over current, clear the over current status immediately.

Depending on the method of use and usage conditions, such as exceeding absolute maximum ratings can cause the over current protection circuit to not operate properly or IC breakdown before operation. In addition, depending on the method of use and usage conditions, if over current continues to flow for a long time after operation, the IC may generate heat resulting in breakdown.

**(2) Thermal Shutdown Circuit**

Thermal shutdown circuits do not necessarily protect ICs under all circumstances. If the thermal shutdown circuits operate against the over temperature, clear the heat generation status immediately.

Depending on the method of use and usage conditions, such as exceeding absolute maximum ratings can cause the thermal shutdown circuit to not operate properly or IC breakdown before operation.

**(3) Heat Radiation Design**

In using an IC with large current flow such as power amp, regulator or driver, please design the device so that heat is appropriately radiated, not to exceed the specified junction temperature ( $T_j$ ) at any time and condition. These ICs generate heat even during normal use. An inadequate IC heat radiation design can lead to decrease in IC life, deterioration of IC characteristics or IC breakdown. In addition, please design the device taking into consideration the effect of IC heat radiation with peripheral components.

**(4) Back-EMF**

When a motor rotates in the reverse direction, stops or slows down abruptly, a current flow back to the motor's power supply due to the effect of back-EMF. If the current sink capability of the power supply is small, the device's motor power supply and output pins might be exposed to conditions beyond absolute maximum ratings. To avoid this problem, take the effect of back-EMF into consideration in system design.

## RESTRICTIONS ON PRODUCT USE

Toshiba Corporation and its subsidiaries and affiliates are collectively referred to as "TOSHIBA". Hardware, software and systems described in this document are collectively referred to as "Product".

- TOSHIBA reserves the right to make changes to the information in this document and related Product without notice.
- This document and any information herein may not be reproduced without prior written permission from TOSHIBA. Even with TOSHIBA's written permission, reproduction is permissible only if reproduction is without alteration/omission.
- Though TOSHIBA works continually to improve Product's quality and reliability, Product can malfunction or fail. Customers are responsible for complying with safety standards and for providing adequate designs and safeguards for their hardware, software and systems which minimize risk and avoid situations in which a malfunction or failure of Product could cause loss of human life, bodily injury or damage to property, including data loss or corruption. Before customers use the Product, create designs including the Product, or incorporate the Product into their own applications, customers must also refer to and comply with (a) the latest versions of all relevant TOSHIBA information, including without limitation, this document, the specifications, the data sheets and application notes for Product and the precautions and conditions set forth in the "TOSHIBA Semiconductor Reliability Handbook" and (b) the instructions for the application with which the Product will be used with or for. Customers are solely responsible for all aspects of their own product design or applications, including but not limited to (a) determining the appropriateness of the use of this Product in such design or applications; (b) evaluating and determining the applicability of any information contained in this document, or in charts, diagrams, programs, algorithms, sample application circuits, or any other referenced documents; and (c) validating all operating parameters for such designs and applications. **TOSHIBA ASSUMES NO LIABILITY FOR CUSTOMERS' PRODUCT DESIGN OR APPLICATIONS.**
- **PRODUCT IS NEITHER INTENDED NOR WARRANTED FOR USE IN EQUIPMENTS OR SYSTEMS THAT REQUIRE EXTRAORDINARILY HIGH LEVELS OF QUALITY AND/OR RELIABILITY, AND/OR A MALFUNCTION OR FAILURE OF WHICH MAY CAUSE LOSS OF HUMAN LIFE, BODILY INJURY, SERIOUS PROPERTY DAMAGE AND/OR SERIOUS PUBLIC IMPACT ("UNINTENDED USE").** Except for specific applications as expressly stated in this document, Unintended Use includes, without limitation, equipment used in nuclear facilities, equipment used in the aerospace industry, medical equipment, equipment used for automobiles, trains, ships and other transportation, traffic signaling equipment, equipment used to control combustions or explosions, safety devices, elevators and escalators, devices related to electric power, and equipment used in finance-related fields. **IF YOU USE PRODUCT FOR UNINTENDED USE, TOSHIBA ASSUMES NO LIABILITY FOR PRODUCT.** For details, please contact your TOSHIBA sales representative.
- Do not disassemble, analyze, reverse-engineer, alter, modify, translate or copy Product, whether in whole or in part.
- Product shall not be used for or incorporated into any products or systems whose manufacture, use, or sale is prohibited under any applicable laws or regulations.
- The information contained herein is presented only as guidance for Product use. No responsibility is assumed by TOSHIBA for any infringement of patents or any other intellectual property rights of third parties that may result from the use of Product. No license to any intellectual property right is granted by this document, whether express or implied, by estoppel or otherwise.
- **ABSENT A WRITTEN SIGNED AGREEMENT, EXCEPT AS PROVIDED IN THE RELEVANT TERMS AND CONDITIONS OF SALE FOR PRODUCT, AND TO THE MAXIMUM EXTENT ALLOWABLE BY LAW, TOSHIBA (1) ASSUMES NO LIABILITY WHATSOEVER, INCLUDING WITHOUT LIMITATION, INDIRECT, CONSEQUENTIAL, SPECIAL, OR INCIDENTAL DAMAGES OR LOSS, INCLUDING WITHOUT LIMITATION, LOSS OF PROFITS, LOSS OF OPPORTUNITIES, BUSINESS INTERRUPTION AND LOSS OF DATA, AND (2) DISCLAIMS ANY AND ALL EXPRESS OR IMPLIED WARRANTIES AND CONDITIONS RELATED TO SALE, USE OF PRODUCT, OR INFORMATION, INCLUDING WARRANTIES OR CONDITIONS OF MERCHANTABILITY, FITNESS FOR A PARTICULAR PURPOSE, ACCURACY OF INFORMATION, OR NONINFRINGEMENT.**
- Do not use or otherwise make available Product or related software or technology for any military purposes, including without limitation, for the design, development, use, stockpiling or manufacturing of nuclear, chemical, or biological weapons or missile technology products (mass destruction weapons). Product and related software and technology may be controlled under the applicable export laws and regulations including, without limitation, the Japanese Foreign Exchange and Foreign Trade Law and the U.S. Export Administration Regulations. Export and re-export of Product or related software or technology are strictly prohibited except in compliance with all applicable export laws and regulations.
- Please contact your TOSHIBA sales representative for details as to environmental matters such as the RoHS compatibility of Product. Please use Product in compliance with all applicable laws and regulations that regulate the inclusion or use of controlled substances, including without limitation, the EU RoHS Directive. **TOSHIBA ASSUMES NO LIABILITY FOR DAMAGES OR LOSSES OCCURRING AS A RESULT OF NONCOMPLIANCE WITH APPLICABLE LAWS AND REGULATIONS.**

# Mouser Electronics

Authorized Distributor

Click to View Pricing, Inventory, Delivery & Lifecycle Information:

[Toshiba:](#)

[TB67S249FTG,EL](#)



Компания «ЭлектроПласт» предлагает заключение долгосрочных отношений при поставках импортных электронных компонентов на взаимовыгодных условиях!

Наши преимущества:

- Оперативные поставки широкого спектра электронных компонентов отечественного и импортного производства напрямую от производителей и с крупнейших мировых складов;
- Поставка более 17-ти миллионов наименований электронных компонентов;
- Поставка сложных, дефицитных, либо снятых с производства позиций;
- Оперативные сроки поставки под заказ (от 5 рабочих дней);
- Экспресс доставка в любую точку России;
- Техническая поддержка проекта, помощь в подборе аналогов, поставка прототипов;
- Система менеджмента качества сертифицирована по Международному стандарту ISO 9001;
- Лицензия ФСБ на осуществление работ с использованием сведений, составляющих государственную тайну;
- Поставка специализированных компонентов (Xilinx, Altera, Analog Devices, Intersil, Interpoint, Microsemi, Aeroflex, Peregrine, Syfer, Eurofarad, Texas Instrument, Miteq, Cobham, E2V, MA-COM, Hittite, Mini-Circuits, General Dynamics и др.);

Помимо этого, одним из направлений компании «ЭлектроПласт» является направление «Источники питания». Мы предлагаем Вам помощь Конструкторского отдела:

- Подбор оптимального решения, техническое обоснование при выборе компонента;
- Подбор аналогов;
- Консультации по применению компонента;
- Поставка образцов и прототипов;
- Техническая поддержка проекта;
- Защита от снятия компонента с производства.



#### Как с нами связаться

**Телефон:** 8 (812) 309 58 32 (многоканальный)

**Факс:** 8 (812) 320-02-42

**Электронная почта:** [org@eplast1.ru](mailto:org@eplast1.ru)

**Адрес:** 198099, г. Санкт-Петербург, ул. Калинина, дом 2, корпус 4, литера А.