

ADVANTECH

Industrial Wireless Training Kit

Global Wireless Standards

Wireless personal area network (WPAN)

Wireless metropolitan area networks (WMAN)

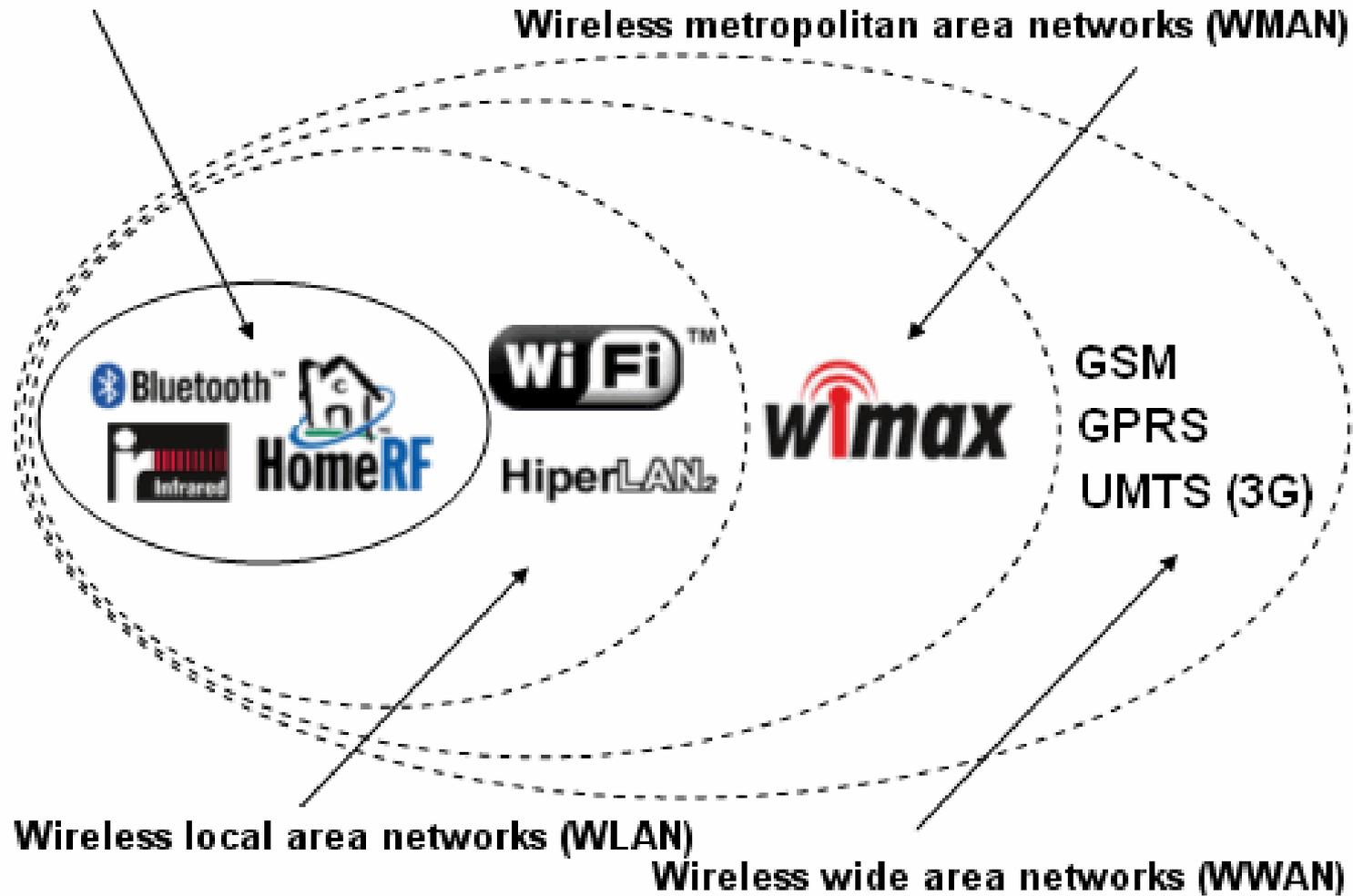

Wireless local area networks (WLAN)

Wireless wide area networks (WWAN)

IoT Focused Segments

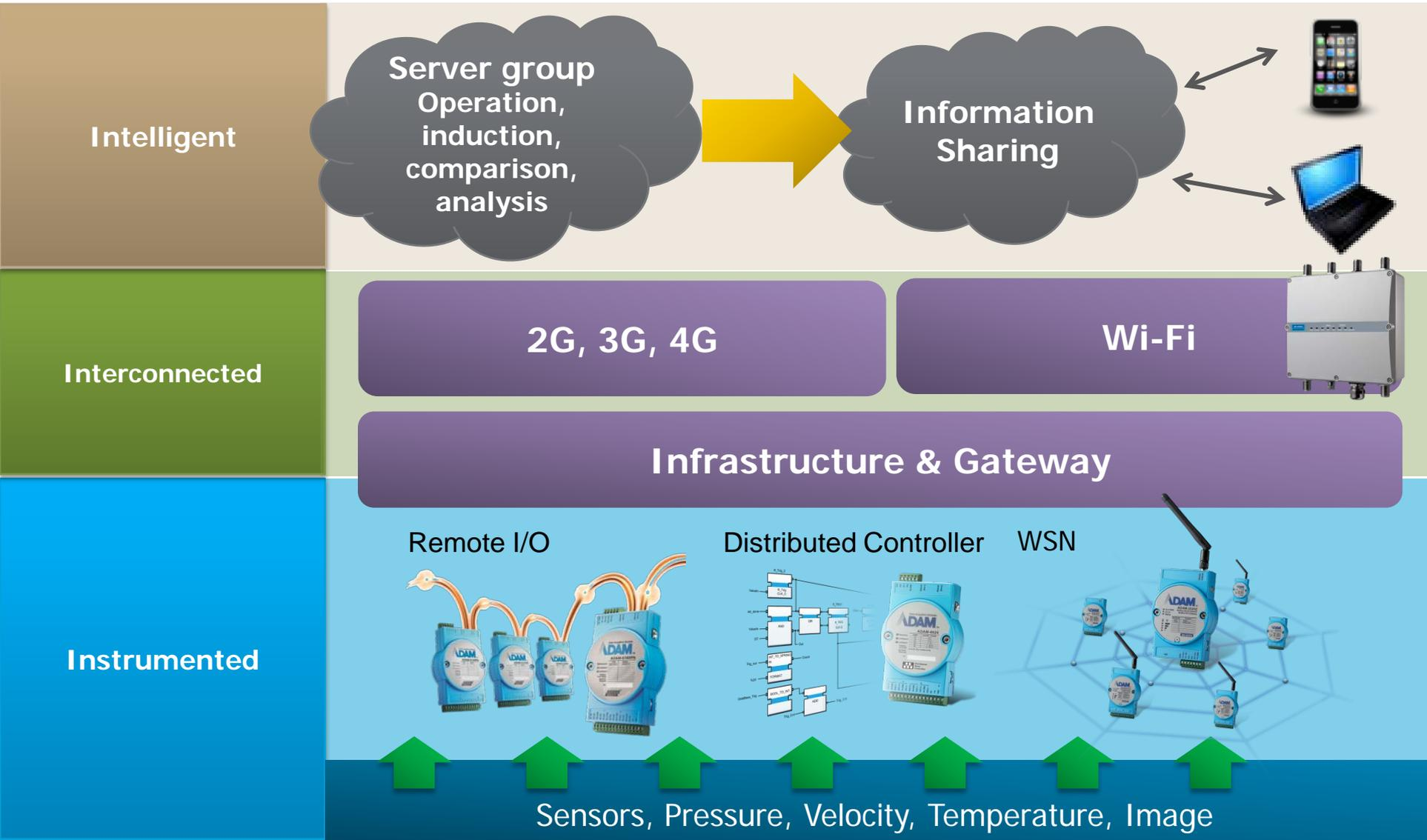

Enabling an Intelligent Planet



Industrial Wireless LAN Product Offering

Multiple Function Mesh AP/CPE



EKI-6351



EKI-6340-1



EKI-6340-2



EKI-6340-3

Entry Level AP/CPE



EKI-6311GN



EKI-6331AN

Single radio

Dual radio

Triple radio

Dual band

Single band

ADVANTECH

Entry-Level AP/CPE EKI-6311GN & EKI-6331AN

Types of WLAN Architecture

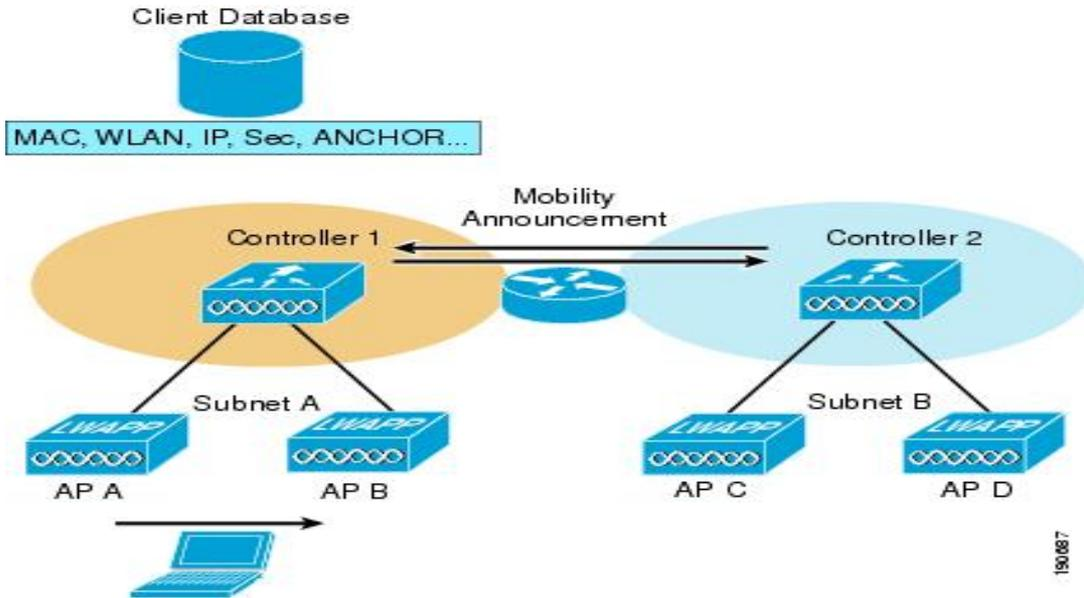

- Infrastructure mode follows Wi-Fi protocol
- Major for simple WLAN App.

Wi-Fi AP/CPE

EKI-6311GN & 6331AN

WMN Solution

- Wireless Mesh Network mode follows Wi-Fi & proprietary protocols
- Target industrial & outdoor users

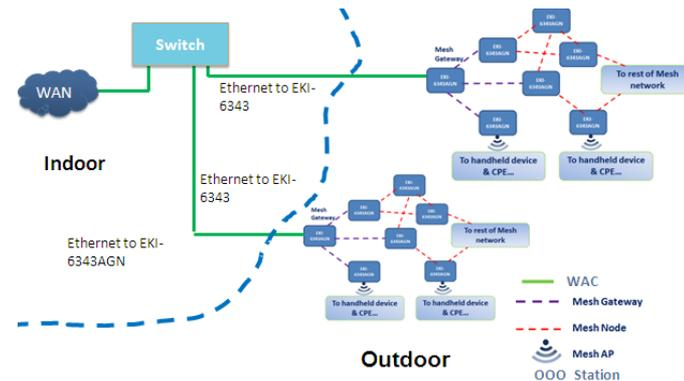

802.11n MIMO Technology



Figure 1. Single Input Single Output (SISO) radio channel access mode

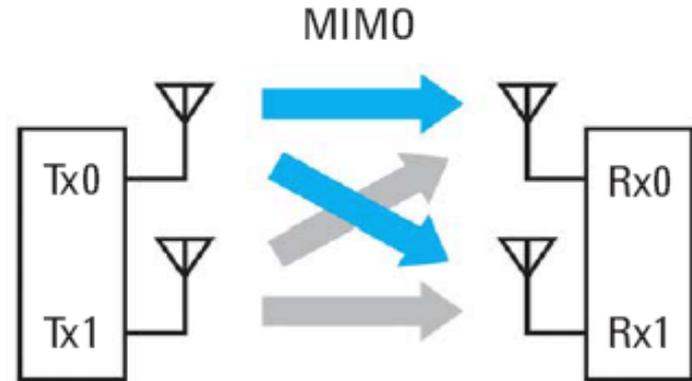

Figure 4. MIMO with two transmitters and two receivers with independent data content

MIMO (Multiple Input Multiple Output) Benefit

- More transmission paths in Tx.
 - **Hundreds of Mb/s** in transmission.
- More receiving paths in Rx.
 - Greater reliability in received **quality**.
 - **Slighter RF interference impact**



Advantech Wi-Fi AP/CPE Offering

802.11b/g/n,
w/MIMO 1X1
EKI-6311GN



802.11a/n,
w/ MIMO 2X2
EKI-6331AN



Rugged Design

- IP-55 rating housing
- Embedded directional antenna
- Operation temp: -20°C ~ 70°C

Rugged Design

- IP-55 rating housing
- Embedded directional antenna
- Operation temp: -20°C ~ 70°C

EKI-6331AN Product Introduction



- WEP/WPA/WPA2 Enterprise/ IEEE 802.1 x authentication security support

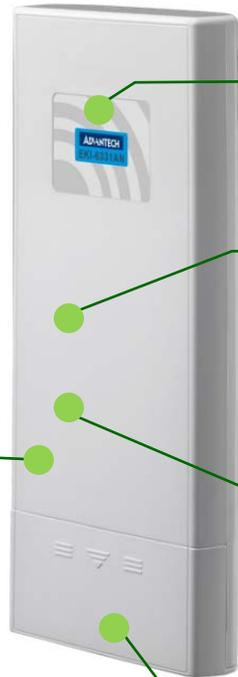

- Supports IEEE802.11a/n wireless standards
 - **High throughput rate: 3 times higher than 11a**
 - **Up to 80Mbps TCP/IP throughput rate**
 - Prevent RF interference from 2.4Ghz
- Built-in MIMO 2x2 to enhance the wireless communication quality
- **Supports up to 10Km with distances with embedded 16dBi directional antenna**
- IP-55 protection grade
- Wide operating temperature range: -20~70°C
- External R-SMA connector for an optional antenna

EKI-6331AN Product Introduction

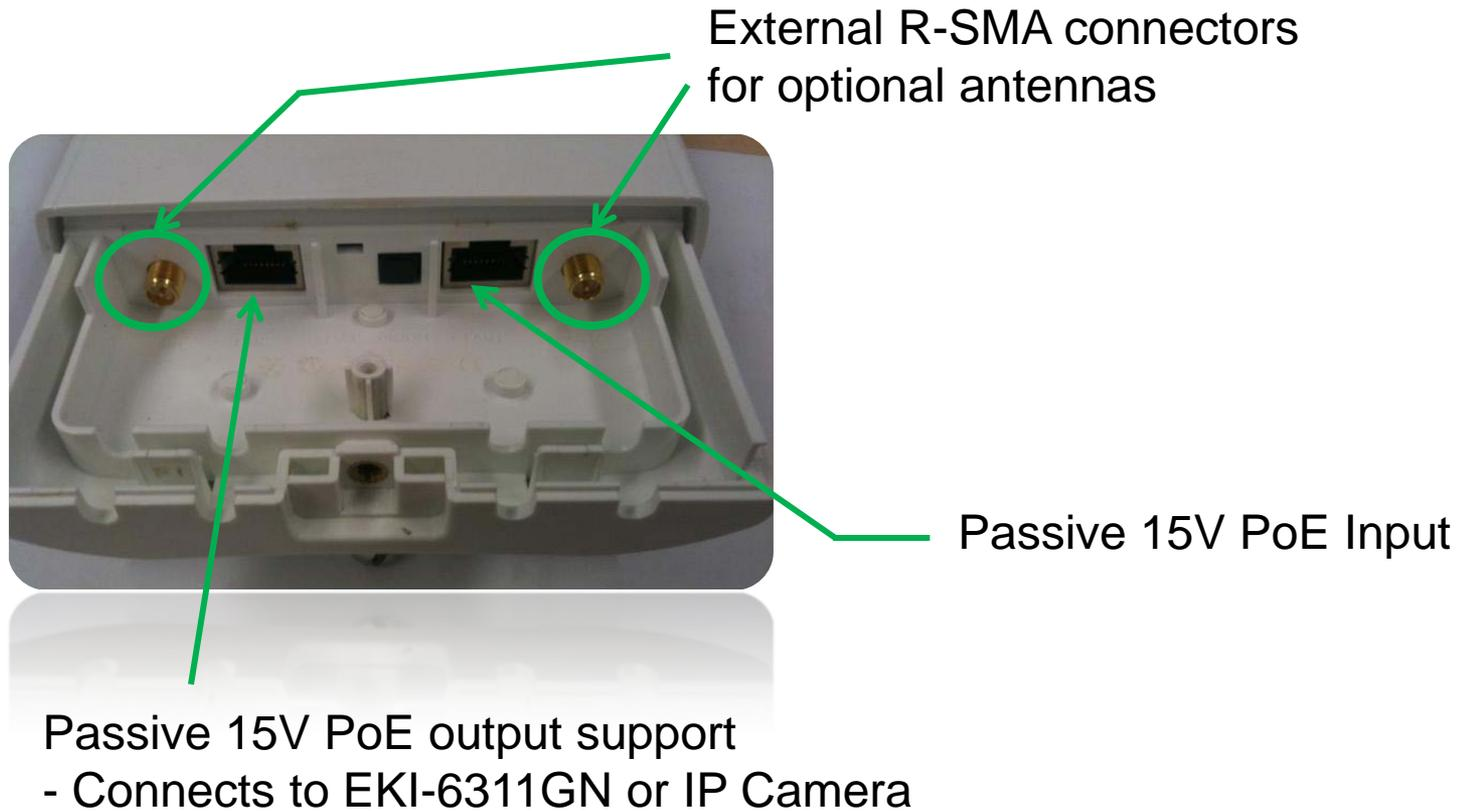

EKI-6311GN Product Introduction

- 
- External N-Type connector for an optional antenna
 - Supports IEEE802.11 b/g/n wireless standards
 - **Higher throughput rate 3 times higher than 11g**
 - **Up to 80Mbps TCP/IP throughput rate**
 - **Supports up to 10Km with distances with embedded 8 dBi directional antenna**
 - **Attached with 5 dBi Omni antenna**
 - IP-55 protection grade
 - Wide operating temperature: -20~70°C
 - □ WEP/WPA/WPA2 Enterprise / IEEE 802.1 x authentication security support

Daisy Chain- Extending Coverage Range

Features: Flexible operating mode in Multi-mode in AP, Client, WDS, Repeater

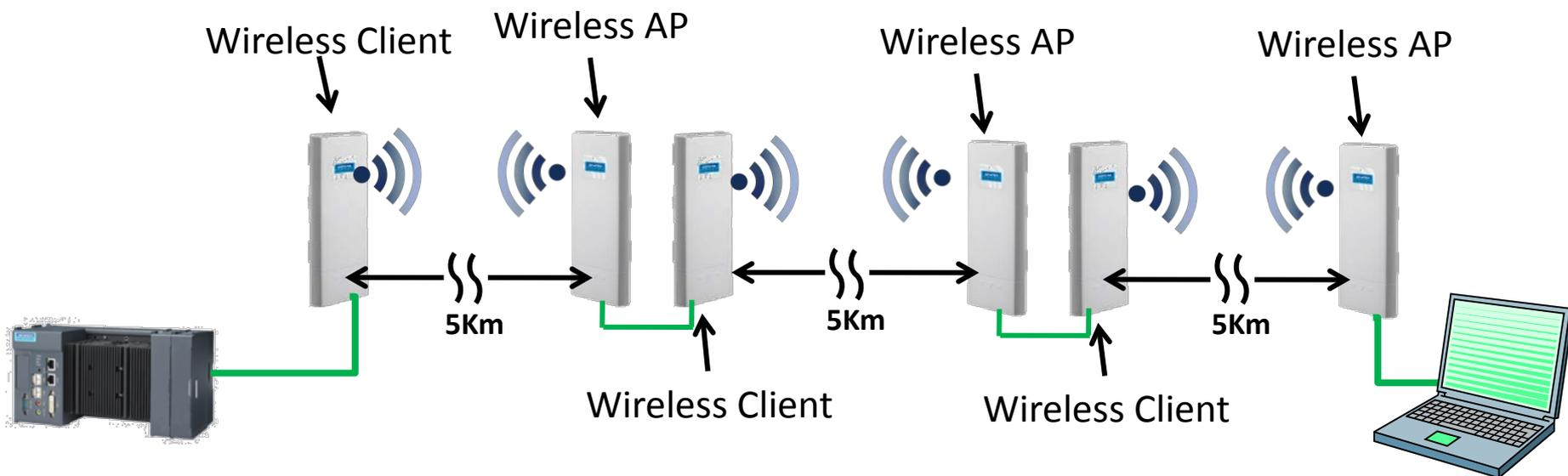

Integration Mode- Backhaul + Coverage

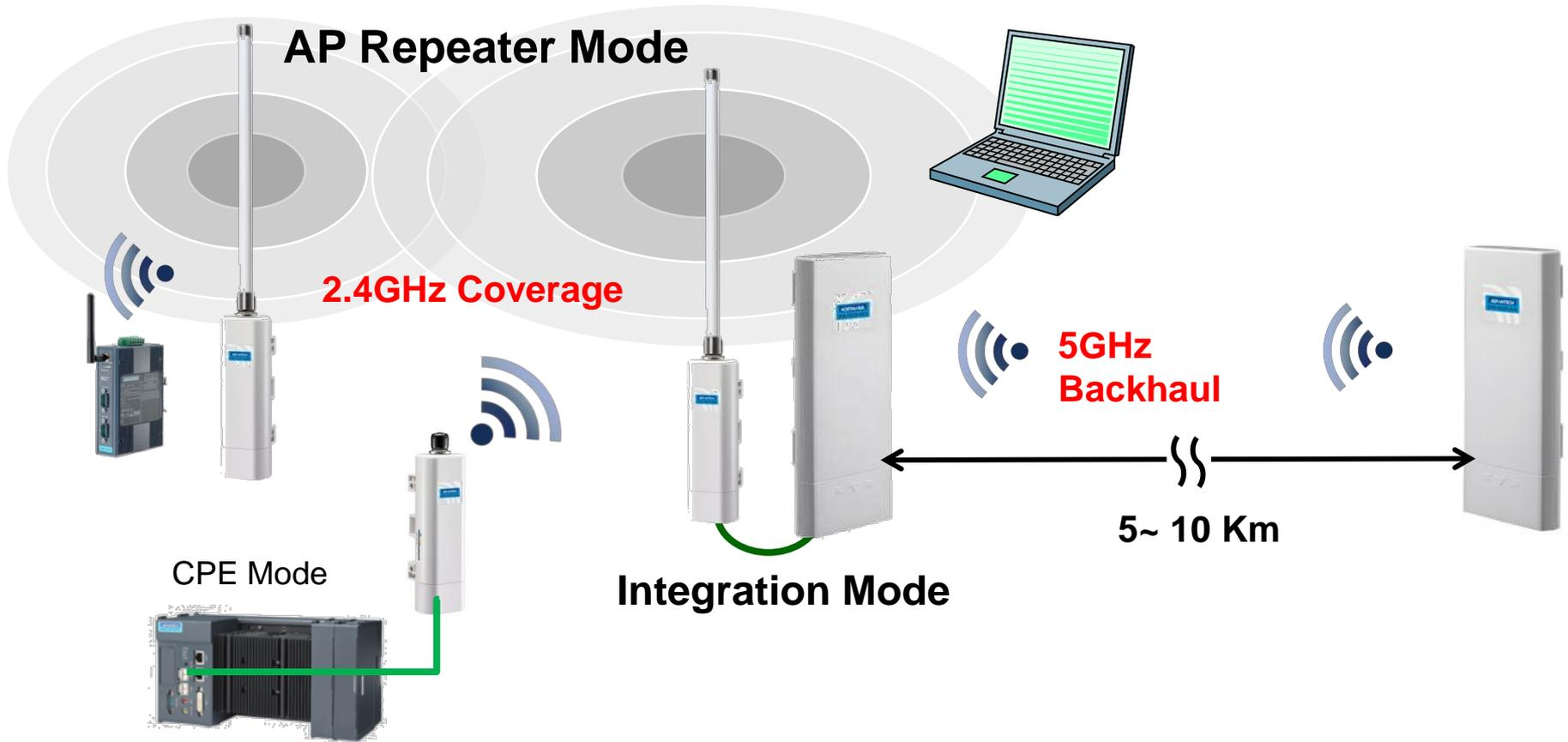

- EKI-6311GN, EKI-6331AN could also seamlessly work together to provide excellent 11n performance for middle-range backhaul + coverage solution.

Application(1): Man-less Factory Monitoring



Application(2): Coal Mining in China

煤礦物聯網

EKI-6331AN
5.8G Wi-Fi Bridge

EKI-6331AN

EKI-6311GN
2.4G Wi-Fi Bridge

EKI-6311GN
AP Repeater

井下黑白攝像機

視屏傳感DTU

傳感DTU

RS-485瓦斯傳感器

RS-485瓦斯傳感器

Application(3): P-2-P for Crane Anti-Collision



EKI-6331AN/ 6311GN Key Selling Points

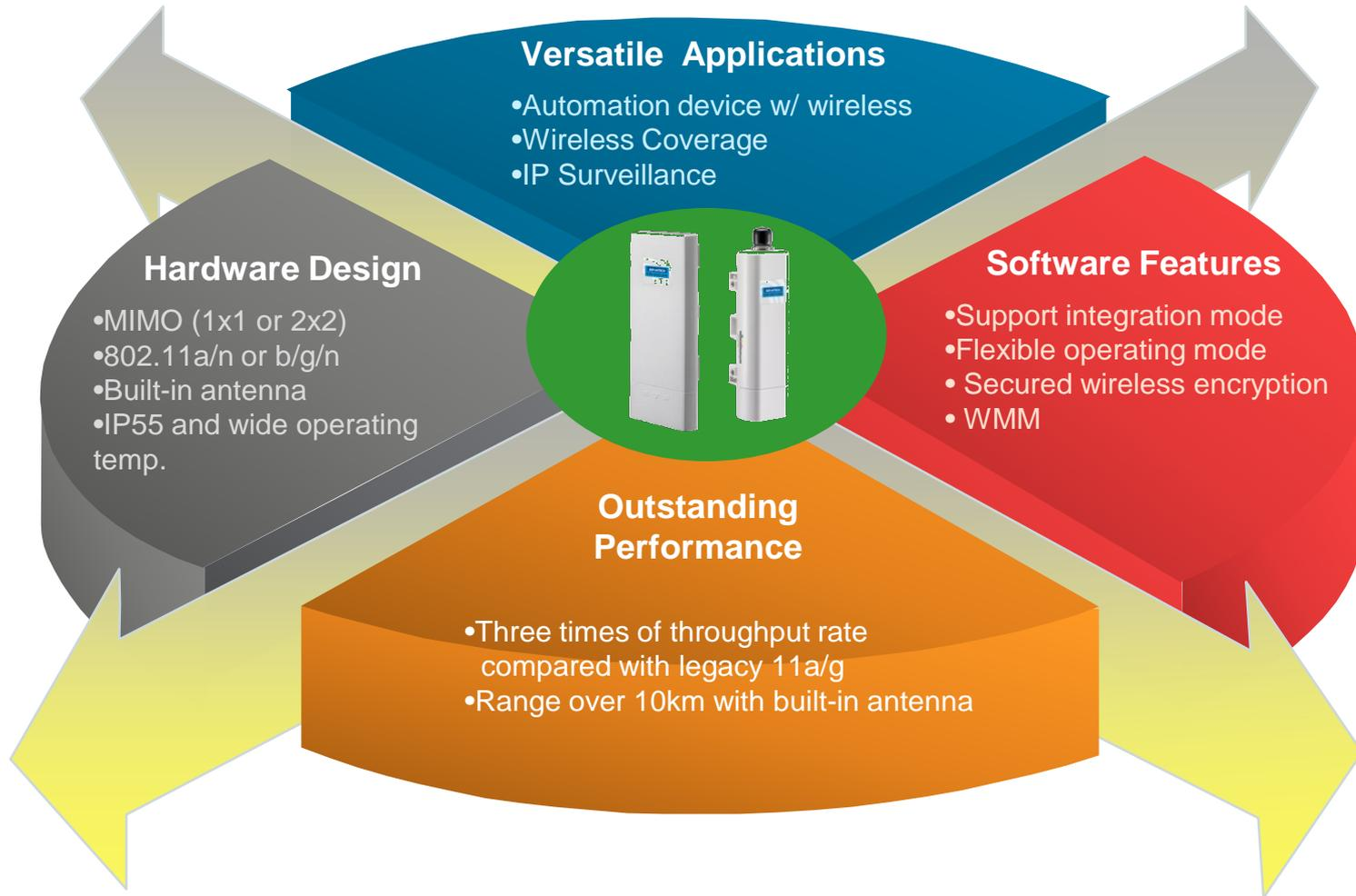

ADVANTECH

EKI-6340

Industrial Wireless Mesh AP

TA Segments & Product positioning

Target Segments

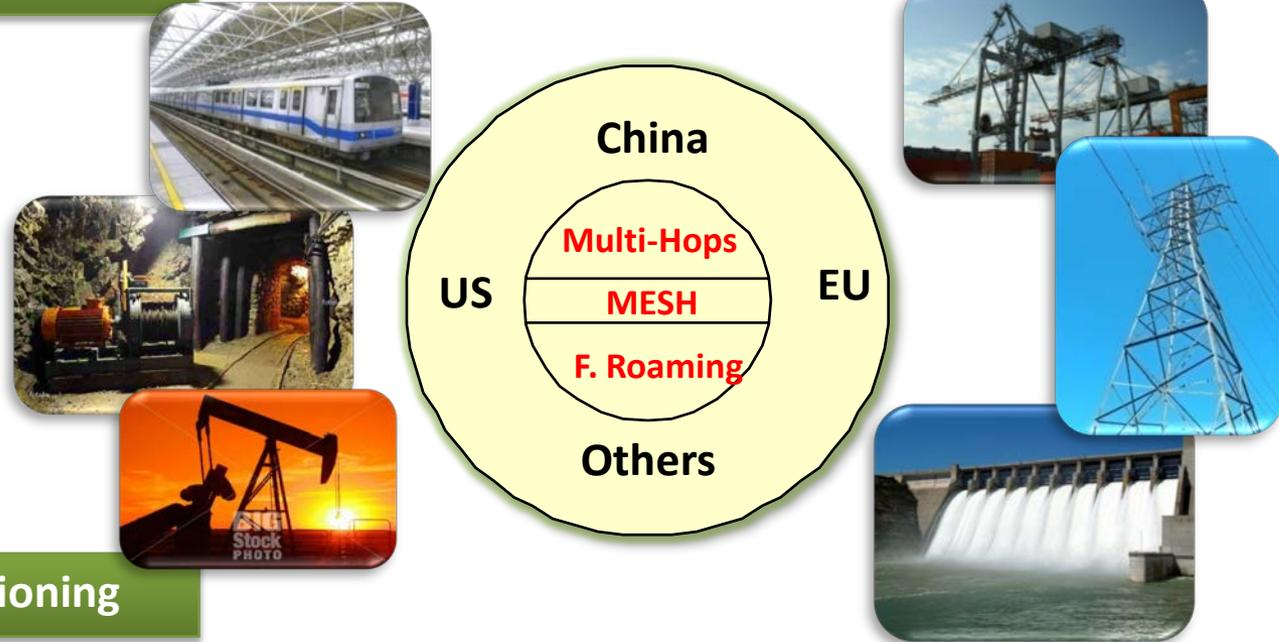

Positioning

EKI-6340 & EKI-6351 are the Industrial Wireless MESH System providing quick and reliable deployment and seamless wireless data communication to free customer from concerns on communication loss

Offered Values by EKI-6340 Series

	Features	Performance
Functional Perspective	IEEE 802.11n+MIMO	300Mbps data rate
	Network Auto-healing	Self-healing
	Multi-hopping	Throughput ≥ 100 Mbps @ 10 hops
	Fast roaming	Handover switching time ≤ 20 ms
	Security	WPA, WPA2-PSK/ EAP, 802.11i
Usage Perspective	Graphical "Ping" Utility	Graphical on-line tool
	RSSI Calculator	Graphical antenna gain calculation tool
	Fresnel Zone Calculator	Graphical antenna & device installation guiding tool
	Antenna Alignment Tool	

Target Markets for Wireless Mesh AP



- Automated Guided Vehicles



- Docks



- Open coal mines



EKI-6340 Series

Outdoor Wireless Mesh AP



EKI-6340-1



EKI-6340-2



EKI-6340-3



EKI-6341

EKI-6342

EKI-6343

- Mesh (Self-forming & Self-healing)
- Multi-hopping w/high throughput
- Ultra fast roaming
- MIMO 2x2
- 35~75°C
- 12~48V_{DC} / PoE Supply
- High security
- IP67 protection

EKI-6351

Wireless Mesh AP/ Station



EKI-6351

EKI-6351

- Mesh (Self-forming & Self-healing)
- Ultra fast roaming
- IP30 protection
- -35°C ~ 75°C
- Support 12-48V_{DC}
- Support 802.3at PoE
- Dual-band (2.4GHz/5GHz)
- MIMO 2x2



Position of Each Model in System

EKI-6340-1	EKI-6340-2	EKI-6340-3	EKI-6351
			
<p>Fast roaming AP</p> <p>-road side with fiber cables installed</p>	<p>Multi-Hopping App.</p> <p>-Extend wireless signal coverage along river, railroad, highway or inside tunnel</p>	<p>Mesh Points or Multi-Hopping App.</p> <p>-Community, campus, park or factory side</p> <p>-As backhaul for road side without fiber cables installed</p>	<p>Mesh Station</p> <p>-Indoor client station</p>

Wireless MESH Network Structure

Reliable Network & Ultra Fast Roaming

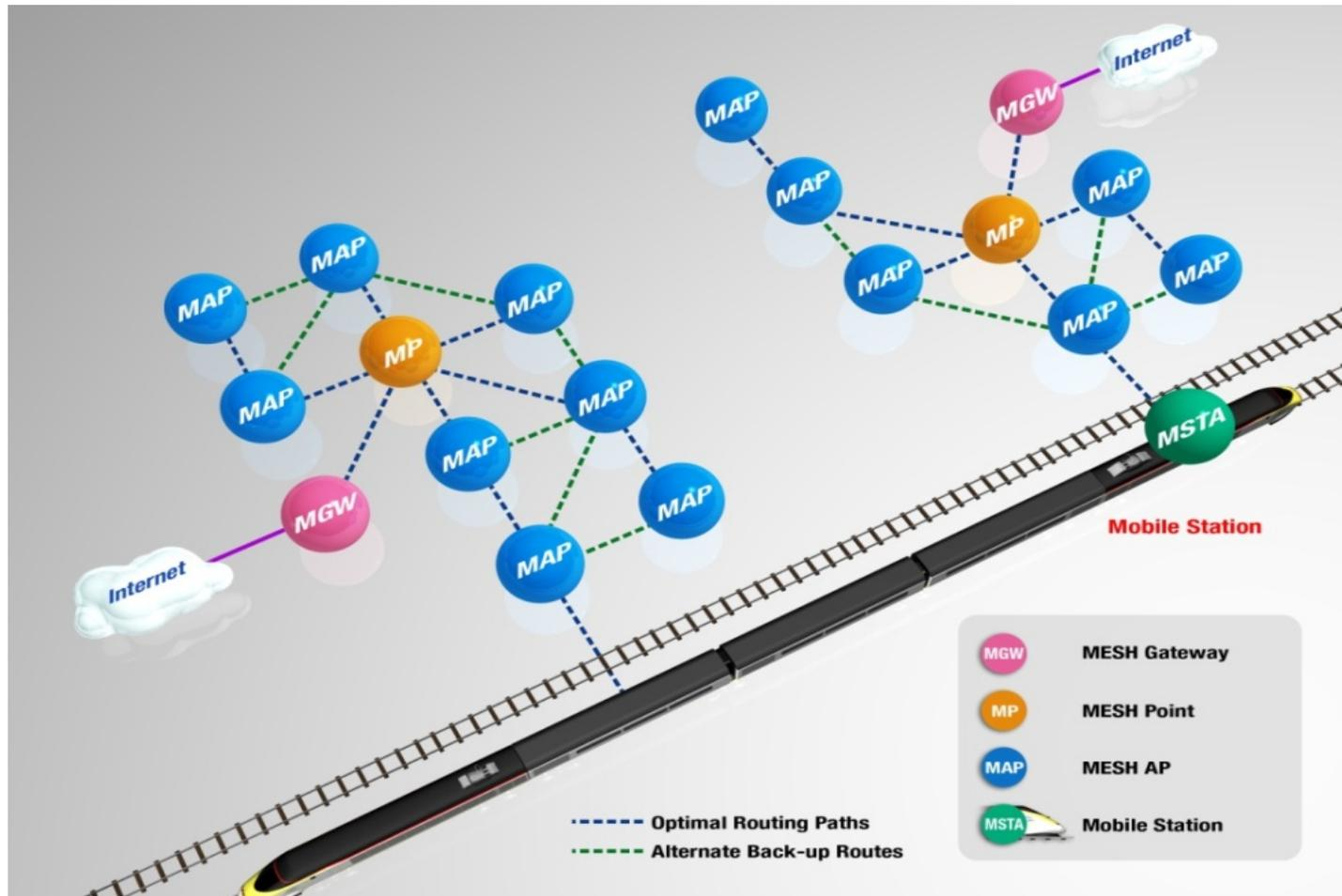

IEEE 802.11n

Significant Throughput Improvement

Through Rate

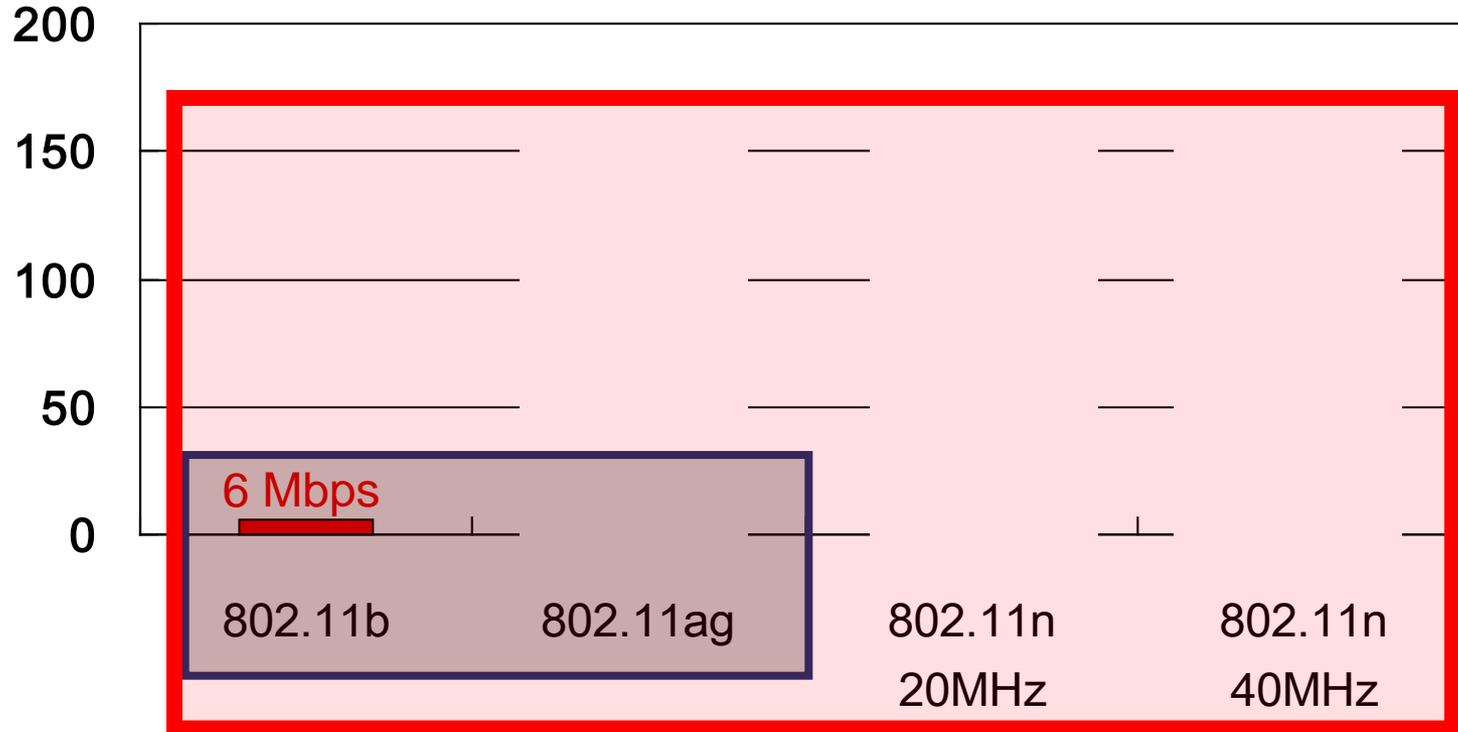

- 802.11n performances are based on 2 Spatial Streams
- 802.11n 2X2 throughput is around 170 Mbps (Data rate: 300M bps)
- 802.11 a/g is around 27 Mbps (Data rate: 54M bps)

Self-Forming & Healing Algorithm

- The self-healing and route choosing algorithms is following the calculation of number of hops and radio signal quality.
- Each wireless connection in a wireless mesh network will have a "*path score*" to represent the signal quality between nodes.
- A *path score* calculation includes RSSI , noise level and bandwidth flow information.
- A number of hops from source to destination will be minor consideration in routing algorithm.

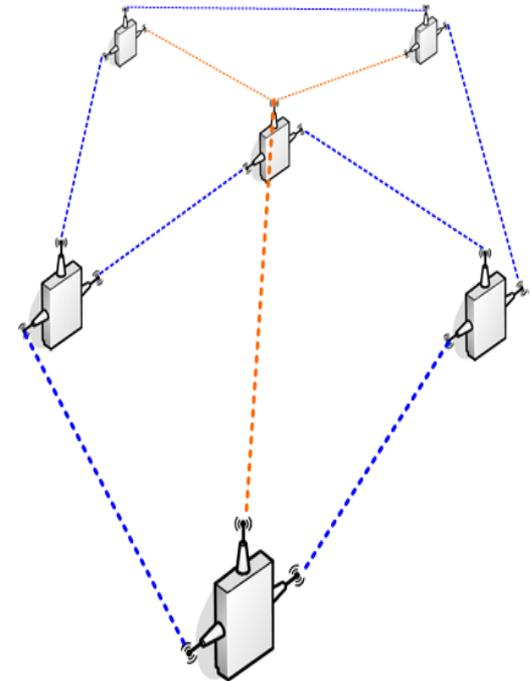

Fast-roaming Algorithm

- Fast roaming is the unique feature of Mesh Station (EKI-6351, not regular Wi-Fi clients)
- Mesh APs are set to periodically & proactively broadcast info. to nearby Mesh Stations.
- The Mesh Stations those who are under the coverage of Mesh APs can periodically generate a list of "*path score*" .
- Once a new "*path score*" is generated and it's better than the "*path score*" of current link, the Mesh Station will handover to another Mesh AP right away without going the procedure of authentication & association.
- The reason that Mesh Station doesn't need to process the authentication & association at the occasion of each handover because those two steps were done already as the Mesh Station joined this Mesh System by processing the registration.



Reference against Competitors

	Brand Model	Advantech EKI-6340-3	Motorola AP 7161	Motorola AP 5181	Cisco Aironet 1552E	Moxa AWK-4131
	Photo					
Wireless	Wi-Fi	802.11 a/b/g/n	802.11 a/b/g/n	802.11 a/b/g	802.11 a/b/g/n	802.11 a/b/g/n
	Freq.	2.4/ 5 Ghz	2.4/ 5 Ghz	2.4/ 5 Ghz	2.4/ 5 Ghz	2.4/ 5 Ghz
	MIMO	2X2	3x3	SISO	2x3	2x2
	Radio #	3	2	2	2	1
Ethernet	Port #	1	1	1	1	1
	Speed	10/100/1000	?	10/100	10/100/1000	10/100/1000
	Fiber	n/a			Fiber SFP	1000 baseSFP
Operation	MESH	Y	Y	Y	Y	n/a
	Fast roaming	< 20 ms	?	?	?	Controller-based
	Muti-hopping	Y	?	?	?	?
	AP/CPE	Y	Y	Y	Y	Y
Power	PoE	802.3at	802.3at	802.3af	802.3af	802.3af
	Input voltage	12~48 Vdc	36~57Vdc	48dc	12 Vdc	12~48 Vdc
	Redudant DC power input	Y	?	?	?	Y
Reliability	IP rating	67	67	56	67	68
Temperature	Operation	-35~75	-40~70	-30~55	-40 to 55°C	-40 to 75°C
Warranty		5 yrs	1 yr	1 yr	90 days	5 yrs

Target Application & Industries

App. Industry	Selling Points
Oil field video monitoring	Multi-hopping and high throughput rate
Driving school exam. system	High throughput rate, fast roaming
Off-shore video monitoring	Mesh(self-forming & self-healing)
Harbor container management	Mesh & high throughput rate
Electric power tower video monitoring	Multi-hopping and high throughput rat
Factory site video monitoring	Multi-hopping and high throughput rate

Oil Field Application

Fully meet application requirements:

Multi-hopping

- Throughput ≥ 150 Mbps @ 2 hops
- Throughput ≥ 100 Mbps @ 10 hops

Mesh Network

- Self-healing

Anti-harsh environment

- IP67 (EKI-6340)
- IP30 (EKI-6351)
- Working temp.: $-35\sim 75^{\circ}\text{C}$

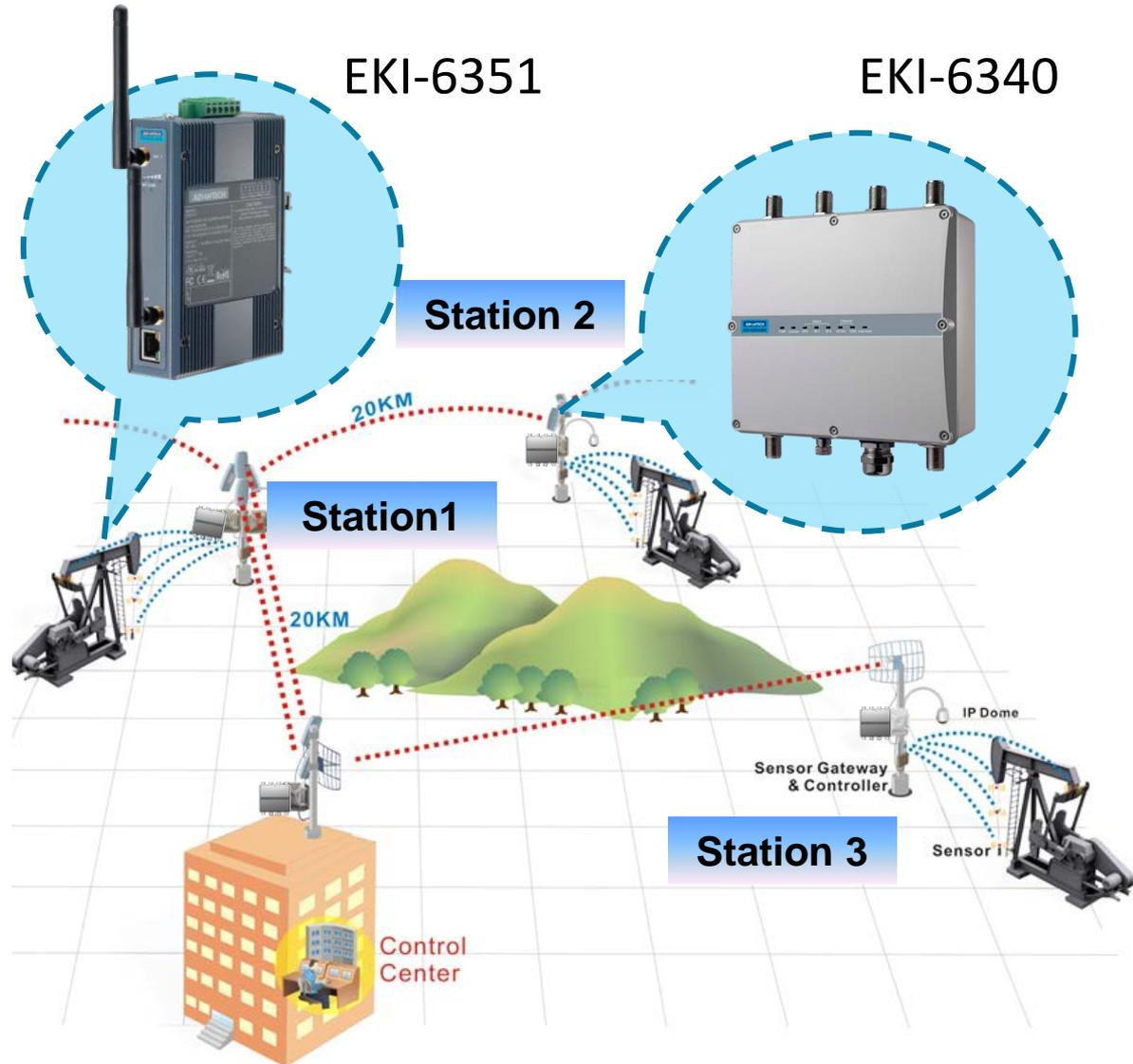

Open Cut Coal Mine

Fully met application requirements:

Multi-hopping

- Throughput ≥ 150 Mbps @ 2 hops
- Throughput ≥ 100 Mbps @ 10 hops

Mesh Network

- Self-healing

Works in harsh environments

- IP67 (EKI-6340)
- IP30 (EKI-6351)
- Working temp.: $-35\sim 75^{\circ}\text{C}$

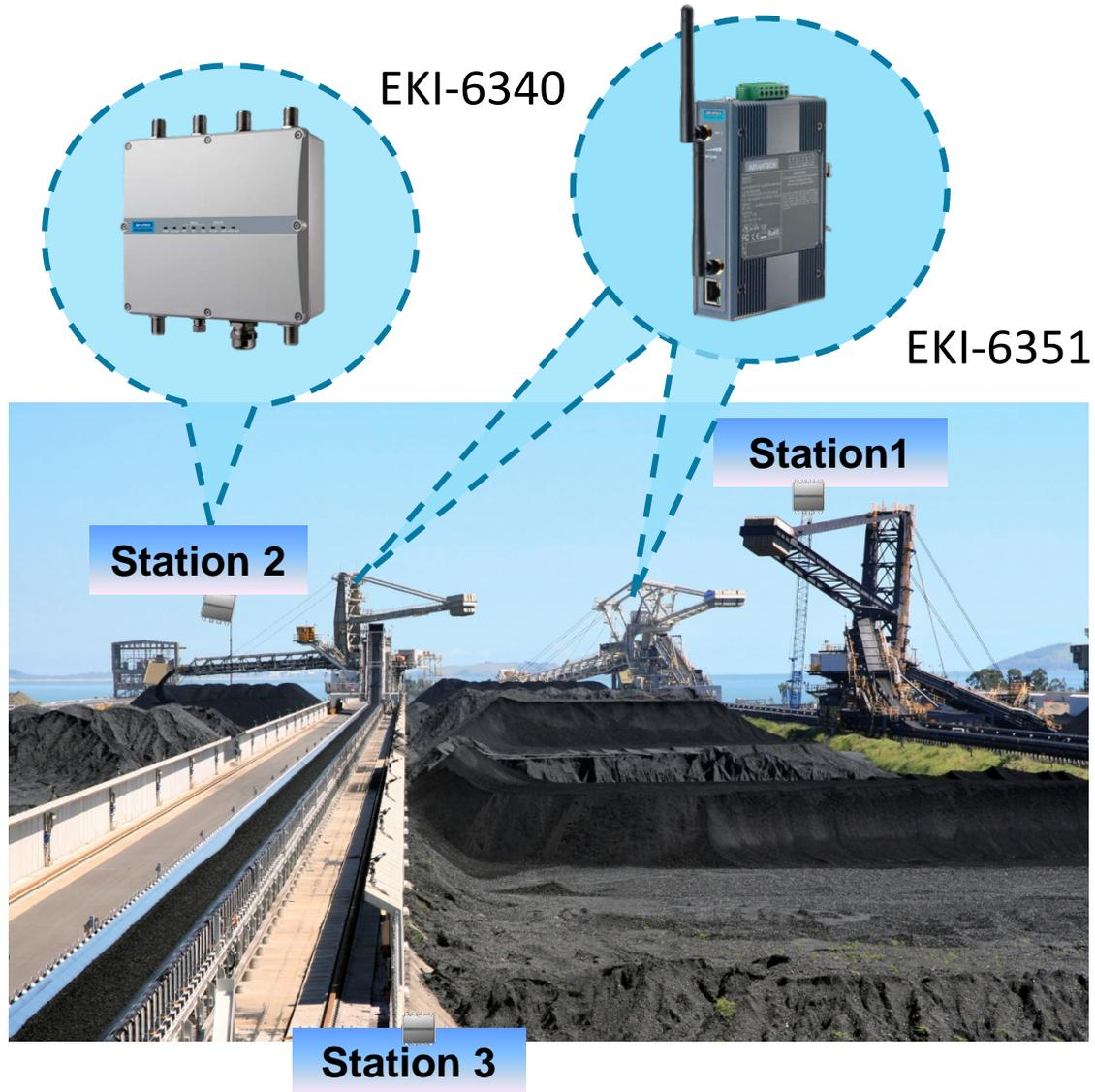

Transportation Application

Fully meet application requirements:

Fast roaming: $\leq 20\text{ms}$

High throughput: $\geq 100\text{Mbps}$

Anti-harsh environment

- IP67 (EKI-6340)
- IP30 (EKI-6351)
- Working temp.: $-35\sim 75^{\circ}\text{C}$



EKI-6340

EKI-6351

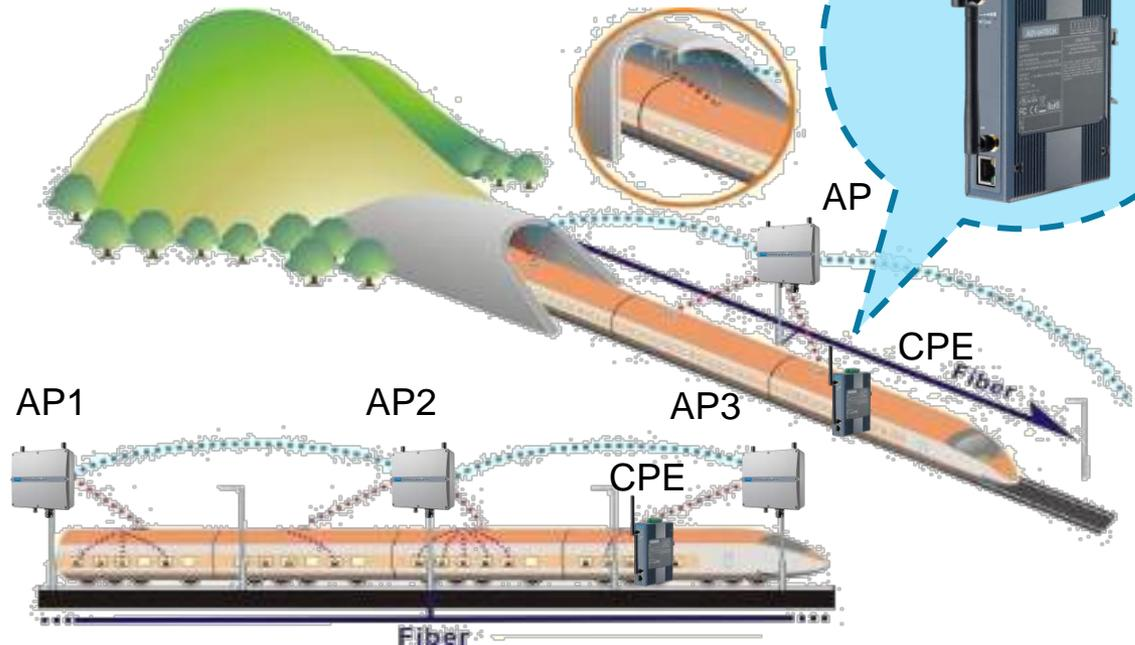

Valuable Tools for Installation & Antenna / Accessory Kits



Enabling an Intelligent Planet

ADVANTECH

RSSI Calculator

RSSI(Received Signal Strength Indication)

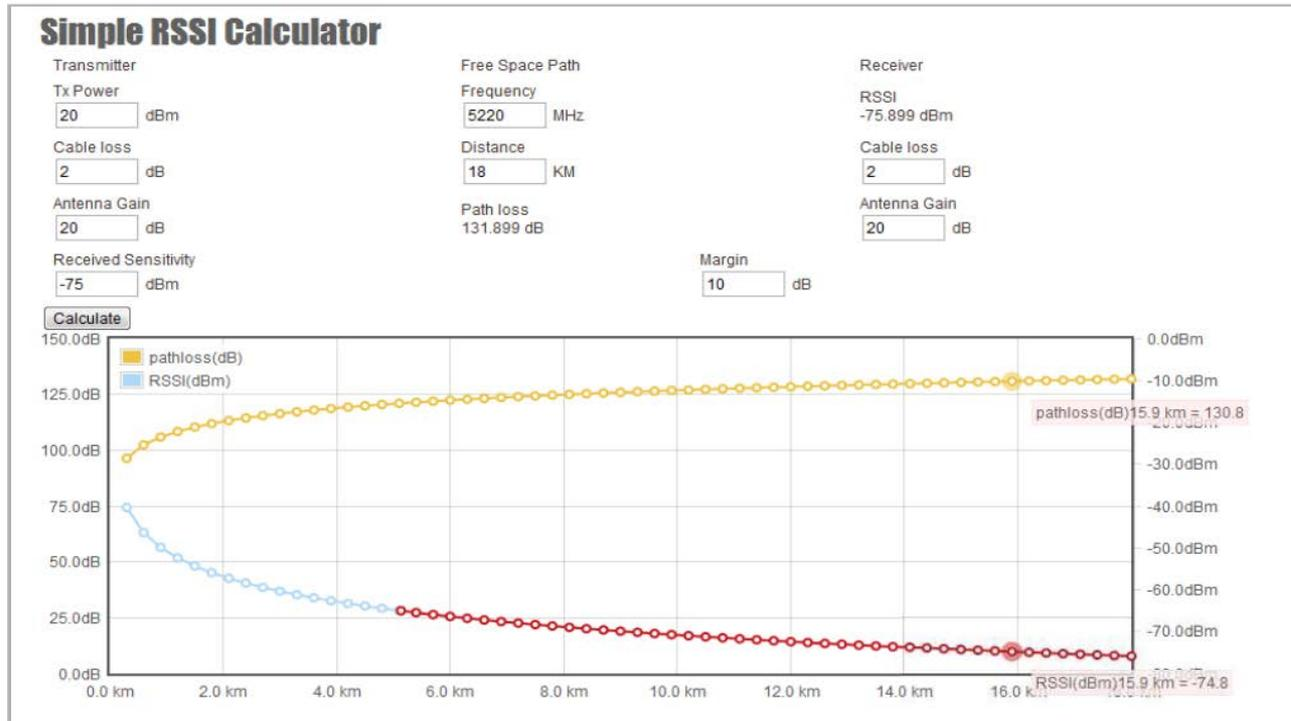

1. Simple RSSI Calculator estimate likely RSSI & path loss
2. Help evaluate selected cable loss & antenna gain by inputting device Tx power and frequency on transmitting and receiving side.
3. Graphically display changes of path loss and RSSI.

Fresnel Zone Calculator

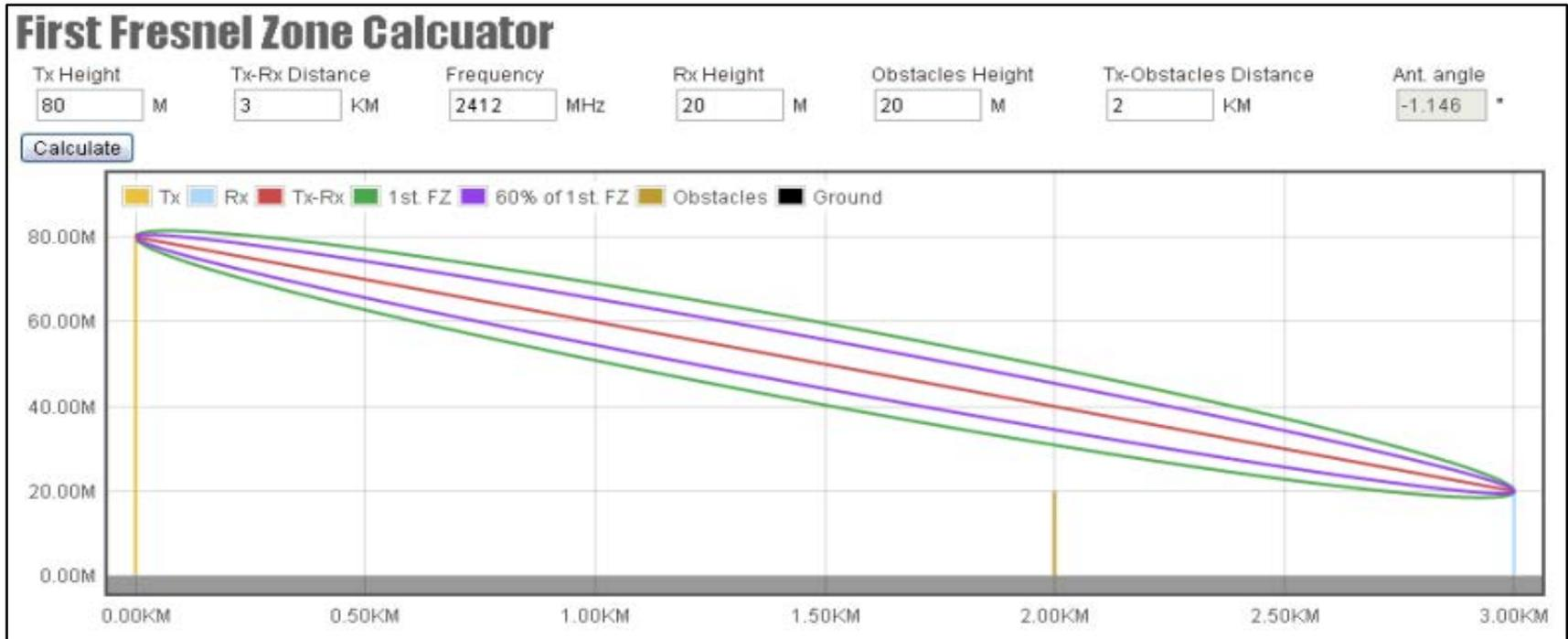

1. The Calculator can estimate the likely obstruction from existing object between two devices
2. The calculator of **antenna angle** calculation can help align the vertical angle of the directional antenna.

Antenna Alignment Tool

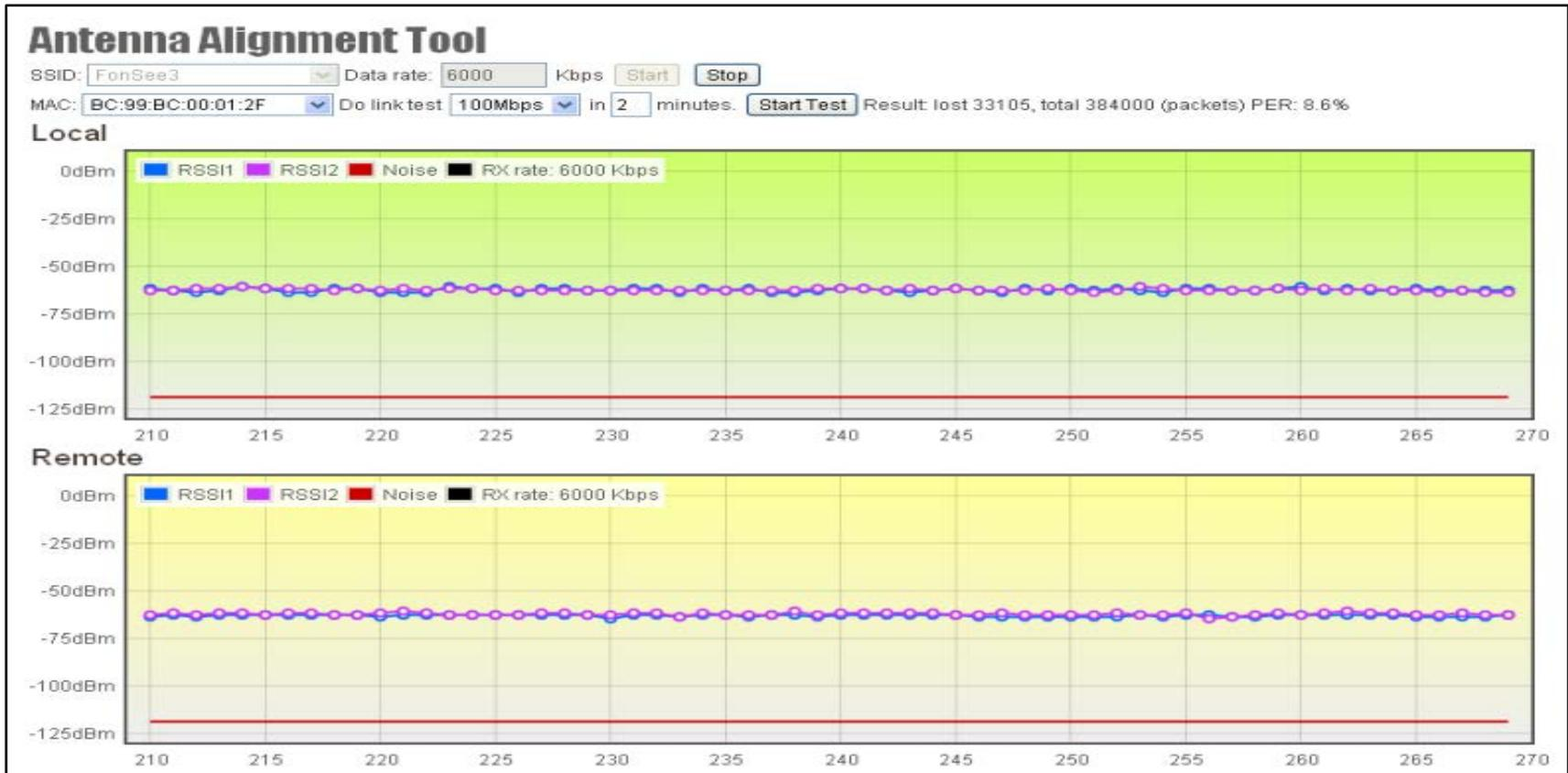

1. The tool aligns and checks the antenna directions.
2. Graphically present RSSI changes in figure help adjust the directional antenna's horizontal and vertical angle to get the best RSSI level.

Antenna, Normal function



Advantech P/N	ANT-1208-G2E	ANT-2209-G2E	ANT-2216-G2E	ANT-3215-G2E	ANT-1208-G5E	ANT-2218-G5E	ANT-3213-G5E
Frequency Range	2.4-2.5G	2.4-2.5G	2.4-2.5G	2.4-2.5G	4.9-5.35G	4.9-5.9G	4.9-5.9G
Antenna Type	Omni	Patch	Patch	Sector	Omni	Patch	Sector
Antenna Gain	8 dBi	9.5 dBi	16 dBi	15 dBi	8 dBi	18 dBi	13.5 dBi
Impedance	50 Ohm	50 Ohm	50 Ohm	50 Ohm	50 Ohm	50 Ohm	50 Ohm
Polarization	Linear, vertical	Linear, vertical	Linear, vertical	Linear, vertical	Linear, vertical	Linear, vertical	Linear, vertical
HPBW/Vertical	360/15	50/50	25/25	90/8	360/12	23/19	120/6
V.S.W.R.	2.0:1 (Max.)	1.5:1 (Max.)	1.5:1 (Max.)	2.0:1 (Max.)	2.0:1 (Max.)	2.0:1 (Max.)	2.0:1 (Max.)
Power Handling	20 W (cw)	20 W (cw)	20 W (cw)	50 W (cw)	20 W (cw)	5 W (cw)	10 W (cw)
Connector	N-Jack	N-Jack	N-Jack	N-Jack	N-Jack	N-Jack	N-Jack
Connector Q'ty	1	1	1	1	1	1	1
Operating temp.	-40 to +80	-40 to +80	-40 to +80	-40 to +80	-40 to +80	-40 to +80	-40 to +80
IP rating	IP55	IP45	IP57	IP55	IP55	IP55	IP55
Weight	0.34 kg	0.14 kg	1.5 kg	1 kg	0.28 kg	0.825 kg	0.55 kg

Antenna, Dual Function (Freq., or Antenna)



Advantech P/N	ANT-2216M-G2E	ANT-3214M-G2E	ANT-2216M-G5E	ANT-3215M-G5E	ANT-1205D-G25E	ANT-1210D-G25E	ANT-2215D-G25E	ANT-3215D-G25E
Frequency Range	2.4-2.5G	2.4-2.5G	5.1-5.9G	5.1-5.9G	2.4-5G; 5.1-5.9G	2.4-5G; 5.1-5.9G	2.4-5G; 5.1-5.9G	2.4-5G; 4.9-5.9G
Antenna Type	Patch	Sector	Patch	Sector	Omni	Omni	Patch	Sector
Antenna Gain	16 dBi	14 dBi	16 dBi	15 dBi	4/7 dBi	8/10 dBi	13.5/15.5 dBi	12/15 dBi
Impedance	50 Ohm	50 Ohm	50 Ohm	50 Ohm	50 Ohm	50 Ohm	50 Ohm	50 Ohm
Polarization	Linear, vertical/horizontal	Linear, vertical	Linear, vertical	Linear, vertical	Linear, vertical	Linear, vertical	Linear, vertical	Linear, vertical
HPBW/Vertical	25/25	90/13	19/21	90/8	360/30	360/13	30/30	70/18
V.S.W.R.	2.0:1 (Max.)	2.0:1 (Max.)	2.0:1 (Max.)	2.0:1 (Max.)	2.0:1 (Max.)	2.0:1 (Max.)	2.0:1 (Max.)	2.0:1 (Max.)
Power Handling	6 W (cw)	10 W (cw)	6 W (cw)	6 W (cw)	2 W (cw)	5 W (cw)	10 W (cw)	10 W (cw)
Connector	N-Jack	N-Jack	N-Jack	N-Jack	N-Plug	N-Jack	N-Jack	N-Jack
Connector Q'ty	2	2	2	2	1	1	1	1
Operating temp.	-40 to +80	-40 to +80	-40 to +80	-40 to +80	-40 to +70	-40 to +80	-40 to +80	-40 to +80
IP rating	IP67	IP55	IP55	IP55	IP55	IP67	IP55	IP55
Weight	1.1 kg	0.8 kg	0.8 kg	1.4 kg	0.07 kg	0.394 kg	0.4 kg	0.462 kg

Antenna Cable, Surge Protector



Advantech P/N	ANT-5115	ANT-5130	ANT-5210	ANT-5230	ANT-5260	ANT-5290
Description	1.5M N-Plug to SMA-Plug cable	3M N-Plug to SMA-Plug cable	1M N-Plug to N-Plug cable	3M N-Plug to N-Plug cable	6M N-Plug to N-Plug cable	9M N-Plug to N-Plug cable
Cable Type	ULA-168	ULA-168	ULA400	ULA400	ULA400	ULA400
VSWR	1.5 : 1 Max. @ DC~3.0 GHz 2.0 : 1 Max. @ 3.0~6.0 GHz	1.5 : 1 Max. @ DC~3.0 GHz 2.0 : 1 Max. @ 3.0~6.0 GHz	1.5 : 1 Max. @ DC~6.0 GHz	1.5 : 1 Max. @ DC~6.0 GHz	1.5 : 1 Max. @ DC~6.0 GHz	1.5 : 1 Max. @ DC~6.0 GHz
Insertion loss	2.0 dB Max. @ DC~3.0 GHz 2.5 dB Max. @ 3.0~6.0 GHz	3.5 dB Max. @ DC~3.0 GHz 4 dB Max. @ 3.0~6.0 GHz	0.7 dB Max. @ DC~3 GHz 1.0 dB Max. @ 3~6.0 GHz	1.1 dB Max. @ DC~3 GHz 1.6 dB Max. @ 3~6.0 GHz	1.8 dB Max. @ DC~3 GHz 2.7 dB Max. @ 3~6.0 GHz	3.0 dB (Max.) @ DC - 3 GHz 4.0 dB (Max.) @ 3 - 6 GHz
Connector Type	N-plug to RP SMA-plug	N-plug to RP SMA-plug	N-plug to N-plug	N-plug to N-plug	N-plug to N-plug	N-plug to N-plug
Cable Length	1.5M	3M	1M	3M	6M	9M



Advantech P/N	ANT-5501	ANT-5502	ANT-5601
Description	1KV Surge Arrestor N-Jack to N-Jack	1KV Surge Arrestor N-Plug to N-Jack	Bulkhead adapter N-Jack to N-Jack
Surge Protection	1KV	1KV	N/A
VSWR	1.25:1 Max @DC~4GHz 1.45:1 Max @4~6GHz	1.3:1 Max @DC~4GHz 1.5:1 Max @4~6GHz	1.2:1 Max @DC~3GHz 1.4:1 Max @3~6GHz
Insertion loss	0.8 dB	0.8 dB	N/A
Connector Type	N Jack to N Jack	N plug to N Jack	N-jack to N-jack

ADVANTECH

Cellular Gateway

GPRS IP Gateway

Compact

- Compact and Slim with solid mounting

Advanced

- Supports versatile gateway features

Efficient

- Supports various communication interfaces

Simplicity

- Easy to use software features

Accurate

- High redundancy with dual SIM and SD slots for data buffering

Reliability

- Robust HW design



EKI-132x Hardware Overview

10/100/1000
Ethernet

5 Band GPRS

Operating Temp
-30 to 65° C

Serial Ports
RS-232/422/485



Dual Power Inputs (12 to 48 VDC)
Reverse Power Polarity Protection
Fault Relay for external PLC/Controller

Dual SIM
SD Slot

Serial ESD Protection: 15KV
2KV EFT/Surge protection for Power
2KV isolation (EKI-1321)

EKI-1321 : 1-port
EKI-1322 : 2-port

Simplicity: Reduced Software Complexity

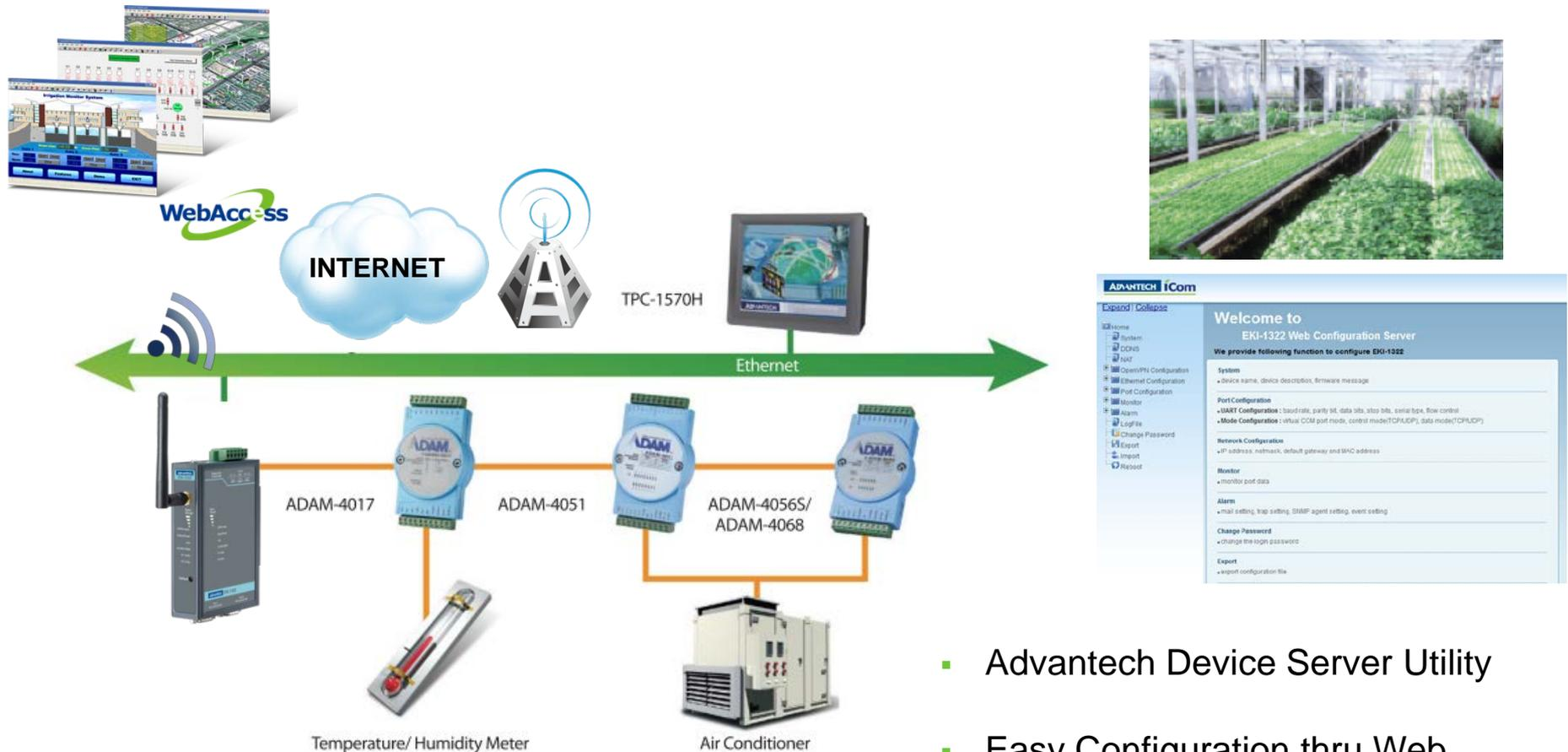

- Advantech Device Server Utility
- Easy Configuration thru Web
- 3~5 Steps to startup...

iGateway Application

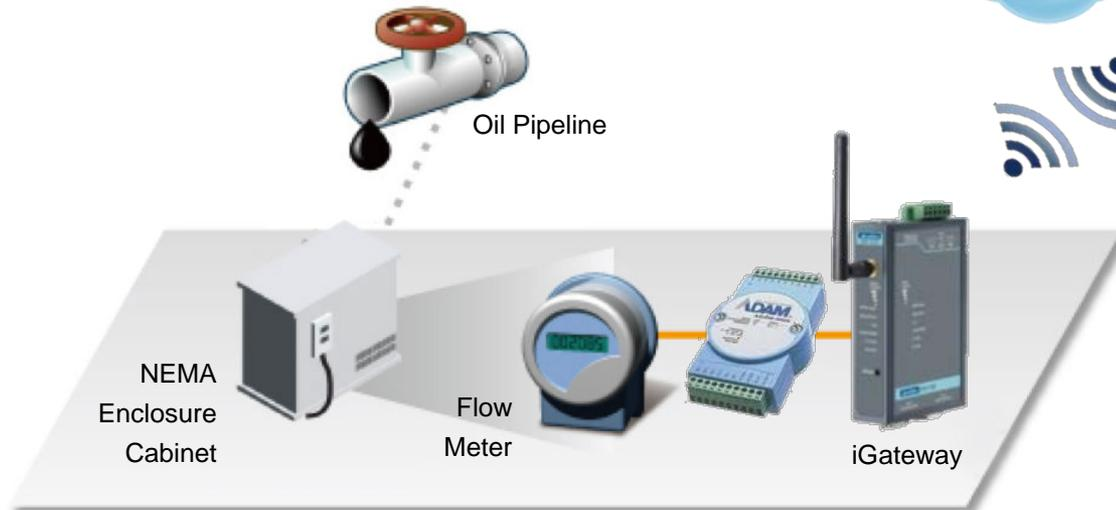
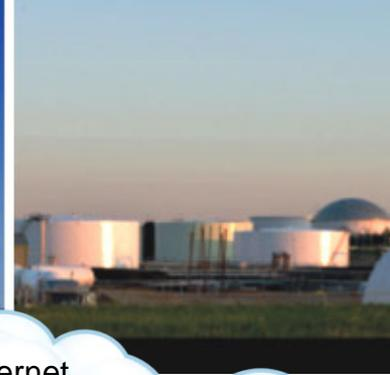

THANK YOU



Enabling an Intelligent Planet

Enabling an Intelligent Planet

ADVANTECH



Компания «ЭлектроПласт» предлагает заключение долгосрочных отношений при поставках импортных электронных компонентов на взаимовыгодных условиях!

Наши преимущества:

- Оперативные поставки широкого спектра электронных компонентов отечественного и импортного производства напрямую от производителей и с крупнейших мировых складов;
- Поставка более 17-ти миллионов наименований электронных компонентов;
- Поставка сложных, дефицитных, либо снятых с производства позиций;
- Оперативные сроки поставки под заказ (от 5 рабочих дней);
- Экспресс доставка в любую точку России;
- Техническая поддержка проекта, помощь в подборе аналогов, поставка прототипов;
- Система менеджмента качества сертифицирована по Международному стандарту ISO 9001;
- Лицензия ФСБ на осуществление работ с использованием сведений, составляющих государственную тайну;
- Поставка специализированных компонентов (Xilinx, Altera, Analog Devices, Intersil, Interpoint, Microsemi, Aeroflex, Peregrine, Syfer, Eurofarad, Texas Instrument, Miteq, Cobham, E2V, MA-COM, Hittite, Mini-Circuits, General Dynamics и др.);

Помимо этого, одним из направлений компании «ЭлектроПласт» является направление «Источники питания». Мы предлагаем Вам помощь Конструкторского отдела:

- Подбор оптимального решения, техническое обоснование при выборе компонента;
- Подбор аналогов;
- Консультации по применению компонента;
- Поставка образцов и прототипов;
- Техническая поддержка проекта;
- Защита от снятия компонента с производства.



Как с нами связаться

Телефон: 8 (812) 309 58 32 (многоканальный)

Факс: 8 (812) 320-02-42

Электронная почта: org@eplast1.ru

Адрес: 198099, г. Санкт-Петербург, ул. Калинина, дом 2, корпус 4, литера А.