

PRODUCT NUMBER	DESCRIPTION	NOTES
10117771-XXXXLF	NON-HF	SEE SHT. 3
10117771-XXXXHLF	HALOGEN FREE (H)	SEE SHT. 3



CABLE
SEE TABLE 2 & 3
NOTE 9 & 15

END P2
MINI SAS
CABLE CONNECTOR

END P1
MINI SAS HD 4X
CABLE CONNECTOR

HEAT SHRINK
TUBE (2X)



P1 LABEL
SEE NOTE 5

A

HEAT SHRINK
TUBE

P2 LABEL
SEE NOTE 5

CABLE TIE COLOR: BLACK
SEE NOTE 10

60mm ± 15mm

(25mm)

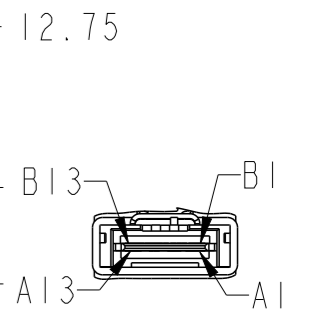

SECTION A-A
SCALE 2:1
CABLE ORIENTATION ONLY
MSAS END P2

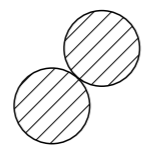

dr	Deborah Ingram	2011/03/17	projection	MM	size	A3	scale	1:1
eng	Tom Feng	2015/08/12			ecn no	ELX-N-21649-1		
chr	-	-			rel level	Released		
appr	Frank Mao	2015/08/12	product family	C&A				
		title Mini SAS HD 4X TO Mini SAS 2.1 TRAINED UNIVERSAL FINAL ASSEMBLY (6Gb/s)		dwg no 10117771	rev C			
www.fci.com		cat. no.	-		Product - Customer Drw		sheet 1 of 5	



Copyright FCI.

PRODUCT NUMBER	DESCRIPTION	NOTES
10117771-XXXXLF	NON-HF	SEE SHT. 3
10117771-XXXXHLF	HALOGEN FREE (H)	SEE SHT. 3



END P1
Mini SAS HD 4X
ISOMETRIC VIEW



END P2
Mini SAS
ISOMETRIC VIEW

dr	Deborah Ingram	2011/03/17	projection 	MM 	size	A3	scale	1:1
eng	Tom Feng	2015/08/12			ecn no	ELX-N-21649-1		
chr	-	-			rel level	Released		
appr	Frank Mao	2015/08/12	product family	C&A				
		title Mini SAS HD 4X TO Mini SAS 2.1 TRAINED UNIVERSAL FINAL ASSEMBLY (6Gb/s)		dwg no 10117771	rev C			
www.fci.com		cat. no.	-	Product - Customer Drw		sheet 2 of 5		

PRODUCT NUMBER	DESCRIPTION	NOTES
10117771-XXXXLF	NON-HF	SEE SHT. 3
10117771-XXXXHLF	HALOGEN FREE (H)	SEE SHT. 3

PRODUCT NUMBER (HALOGEN FREE) SEE NOTE 9 & 15	AWG	"DIM L" LENGTH (Meters)	"DIM M" HIEGHT (mm)
10117771-5030HLF	24 AWG	3 M	(20.1)
10117771-5040HLF	24 AWG	4 M	(20.1)
10117771-5050HLF	24 AWG	5 M	(20.1)
10117771-5060HLF	24 AWG	6 M	(20.1)
10117771-5070HLF	24 AWG	7 M	(20.1)
10117771-5080HLF	24 AWG	8 M	(20.1)
10117771-5090HLF	24 AWG	9 M	(20.1)
10117771-5100HLF	24 AWG	10 M	(20.1)
10117771-4020HLF	26 AWG	2 M	(20.1)
10117771-4030HLF	26 AWG	3 M	(20.1)
10117771-4040HLF	26 AWG	4 M	(20.1)
10117771-4050HLF	26 AWG	5 M	(20.1)
10117771-4060HLF	26 AWG	6 M	(20.1)
10117771-4070HLF	26 AWG	7 M	(20.1)
10117771-4080HLF	26 AWG	8 M	(20.1)
10117771-3010HLF	28 AWG	1 M	(17.3)
10117771-3020HLF	28 AWG	2 M	(17.3)
10117771-3030HLF	28 AWG	3 M	(17.3)
10117771-3040HLF	28 AWG	4 M	(17.3)
10117771-3050HLF	28 AWG	5 M	(17.3)
10117771-3060HLF	28 AWG	6 M	(17.3)
10117771-2005HLF	30 AWG	0.5 M	(17.3)
10117771-2010HLF	30 AWG	1 M	(17.3)
10117771-2020HLF	30 AWG	2 M	(17.3)
10117771-2030HLF	30 AWG	3 M	(17.3)
10117771-2040HLF	30 AWG	4 M	(17.3)

PRODUCT NUMBER (NON-HALOGEN FREE) SEE NOTE 15	AWG	"DIM L" LENGTH (Meters)	"DIM M" HIEGHT (mm)
10117771-5030LF	24 AWG	3 M	(20.1)
10117771-5040LF	24 AWG	4 M	(20.1)
10117771-5050LF	24 AWG	5 M	(20.1)
10117771-5060LF	24 AWG	6 M	(20.1)
10117771-5070LF	24 AWG	7 M	(20.1)
10117771-5080LF	24 AWG	8 M	(20.1)
10117771-5090LF	24 AWG	9 M	(20.1)
10117771-5100LF	24 AWG	10 M	(20.1)
10117771-4020LF	26 AWG	2 M	(20.1)
10117771-4030LF	26 AWG	3 M	(20.1)
10117771-4040LF	26 AWG	4 M	(20.1)
10117771-4050LF	26 AWG	5 M	(20.1)
10117771-4060LF	26 AWG	6 M	(20.1)
10117771-4070LF	26 AWG	7 M	(20.1)
10117771-4080LF	26 AWG	8 M	(20.1)
10117771-3010LF	28 AWG	1 M	(17.3)
10117771-3020LF	28 AWG	2 M	(17.3)
10117771-3030LF	28 AWG	3 M	(17.3)
10117771-3040LF	28 AWG	4 M	(17.3)
10117771-3050LF	28 AWG	5 M	(17.3)
10117771-3060LF	28 AWG	6 M	(17.3)
10117771-2005LF	30 AWG	0.5 M	(17.3)
10117771-2010LF	30 AWG	1 M	(17.3)
10117771-2020LF	30 AWG	2 M	(17.3)
10117771-2030LF	30 AWG	3 M	(17.3)
10117771-2040LF	30 AWG	4 M	(17.3)

dr	Deborah Ingram	2011/03/17	projection 	size A3	scale 1:1
eng	Tom Feng	2015/08/12			
chr	-	-			
appr	Frank Mao	2015/08/12	product family	C&A	rel level Released
		title Mini SAS HD 4X TO Mini SAS 2.1 TRAINED UNIVERSAL FINAL ASSEMBLY (6Gb/s)		dwg no 10117771	rev C
www.fci.com		cat. no.	Product - Customer Drw		sheet 3 of 5



Copyright FCI.

PRODUCT NUMBER	DESCRIPTION	NOTES
10117771-XXXXLF	NON-HF	SEE SHT. 3
10117771-XXXXHLF	HALOGEN FREE (H)	SEE SHT. 3



KEY 3 & KEY SLOT 2, 4 & 6
 ○ ◇ UNIVERSAL PORT

**END P2
MINI SAS**

**MINI SAS HD
MINIMUM BEND TABLE**

CABLE	"DIM Y" (HF)	"DIM Y" (NON-HF)
24 AWG	92.8	90.5
26 AWG	87.5	85.1
28 AWG	81.5	79.1
30 AWG	77.9	74.3

**MINI SAS 2.1
MINIMUM BEND TABLE**

CABLE	"DIM Y" (HF)	"DIM Y" (NON-HF)
24 AWG	90.6	88.3
26 AWG	85.3	82.9
28 AWG	79.3	76.9
30 AWG	75.7	72.1



**PEND RADIUS
TOP VIEW OF CONNECTOR**

WIRING LIST (SEE NOTE 6)				
P1 (MINI SAS HD)		CONDUCTOR #	P2 (MINI SAS)	
SIGNAL	PIN#		PIN#	SIGNAL
GND	A9	PAIR 2	B7	GND
Rx 1-	A5		B6	Tx 1-
Rx 1+	A4		B5	Tx 1+
GND	A3	PAIR 4	B4	GND
Rx 3-	A8		B12	Tx 3-
Rx 3+	A7		B11	Tx 3+
GND	A6	NO THRU CONNECTION	B13	GND
N/C	A1			
Interrupt	A2			
GND	B9	PAIR 1		GND
RX 0-	B5		B3	TX 0-
RX 0+	B4		B2	TX 0+
GND	B3	PAIR 3	B1	GND
RX 2-	B8		B9	TX 2-
RX 2+	B7		B8	TX 2+
GND	B6	NO THRU CONNECTION	B10	GND
N/C	B1			
Mod_PRS_L (GND)	B2			
GND	C9	PAIR 2	A7	GND
TX 1-	C5		A6	RX 1-
TX 1+	C4		A5	RX 1+
GND	C3	PAIR 4	A4	GND
TX 3-	C8		A12	RX 3-
TX 3+	C7		A11	RX 3+
GND	C6	NO THRU CONNECTION	A13	GND
SCL	C1			
SDA	C2			
GND	D9	PAIR 1		GND
TX 0-	D5		A3	RX 0-
TX 0+	D4		A2	RX 0+
GND	D3	PAIR 3	A1	GND
TX 2-	D8		A9	RX 2-
TX 2+	D7		A8	RX 2+
GND	D6	NO THRU CONNECTION	A10	GND
N/C	D1			
V+3.3 for EEPROM	D2			
SHELL		BRAID		SHELL

dr	Deborah Ingram	2011/03/17	projection 	MM 	size	A3	scale	1:1
eng	Tom Feng	2015/08/12			ecn no	ELX-N-21649-1		
chr	-	-			rel level	Released		
appr	Frank Mao	2015/08/12			product family	C&A		
		Mini SAS HD 4X TO Mini SAS 2.1 TRAINED UNIVERSAL FINAL ASSEMBLY (6Gb/s)		dwg no 10117771	rev C			
www.fci.com		cat. no.	-	Product - Customer Drw	sheet 4 of 5			

PRODUCT NUMBER	DESCRIPTION	NOTES
10117771-XXXXLF	NON-HF	SEE SHT. 3
10117771-XXXXHLF	HALOGEN FREE (H)	SEE SHT. 3

NOTES:

1 - MATERIALS MINI SAS HD (END P1)
 BACK SHELLS: ZINC DIE CAST/ COPPER UNDER PLATE/NICKEL OVER PLATE
 PULL TAB: THERMOPLASTIC POLYMER
 LATCH: STAINLESS STEEL
 FERRULE: BRASS
 EMI GASKETS: STAINLESS STEEL
 LOCTITE
 HEAT SHRINK: HIGH POLYMER
 PADDLE CARD: PRINTED CIRCUIT SUBSTRATE

MATERIALS MINI SAS (END P2)
 BACK SHELLS: ZINC DIE CAST
 PULL TAB: THERMOPLASTIC POLYMER
 LATCH: STAINLESS STEEL
 JET MELT: POLYAMIDE POLYMER
 HEAT SHRINK: POLYOLEFIN
 PADDLE CARD: PRINTED CIRCUIT SUBSTRATE

△ CABLE LABEL EXAMPLE:



FCI SERIAL NUMBER IS ONLY USED FOR TRACKING PRODUCT ,
 SERIAL NUMBER IS DEFINED AS BELOW:



CE MARK VERTICAL DIMENSION MAY NOT BE LESS THAN 5mm,

2 - ELECTRICAL PERFORMANCE PER CURRENT REVISION: T10/SAS-2.1

△ 3 - THIS PRODUCT MEETS THE RESTRICTION OF HAZARDOUS SUBSTANCES IN ELECTRICAL AND ELECTRONIC EQUIPMENT (ROHS) DIRECTIVE (2011/65/EU)

△ 4 - UNLESS OTHERWISE SPECIFIED ASSEMBLED LENGTH TOLERANCE IS TO BE:
 "DIM L" < 1 METERS = ±25mm
 "DIM L" = 1 METER TO 10 METER = 2% OF "DIM L"

5- LABEL DETAILS:

MANUFACTURER CODE OR NAME	COUNTRY ORIGIN
FCI P/N	CE MARK
FCI CUSTOMER DRAWING REVISION	
FCI SERIAL NUMBER	
BAR CODE OF SERIAL NUMBER	

FONT SHALL BE CLEARLY VISIBLE AND BLACK IN COLOR.
 CE MARK VERTICAL DIMENSION MAY NOT BE LESS THAN 5mm.

6- ALL CABLE ASSEMBLIES SHALL BE 100% TESTED FOR CONTINUITY AS DEFINED IN WIRING LIST.

7 -PACKAGING OF LEAD FREE PRODUCTS MEETS LABELING AND PACKAGING PER SPECIFICATION GS-14-920.
 △ PACKAGE CABLE ASSEMBLIES PER GS-14-1272. DUST COVER IS TO BE APPLIED TO MINI SAS HD CONNECTOR PRIOR TO SHIPPING.
 CE MARK SHOULD BE ADDED ON FCI STANDARD PACKAGE LABEL(G1 LABEL),CE MARK VERTICAL DIM. MAY NOT BE LESS THAN 5mm.

8- THIS DIMENSION IS A FINISHED PRODUCT LENGTH.

9. "H" IN THE PART NUMBER DENOTES USE OF HALOGEN FREE CABLE.

10. PLACE A CABLE TIE EVERY 0.5 METERS, IN THE CASE OF A 0.5 METER CABLE LENGTH, PLACE THE CABLE TIE MIDWAY BETWEEN CONNECTORS.

11. A "△" SYMBOL WILL BE NEXT TO ANY DIMENSION, VIEW, OR NOTE WHICH HAS BEEN MODIFIED WITH THE CURRENT DRAWING REVISION. THE CURRENT REVISION WILL BE SHOWN IN THE SYMBOL.

12. MATES TO SERIES: MINI SAS HD - 10112626 or 10112627 or 10112628
 MINI SAS 2.1 - BOARD CONNECTOR 10098870 AND CAGE 10098871

13. OTHER TESTING PERFORMED AS REQUIRED BY PRODUCT SPECIFICATION: MINISAS HD GS-12-651, MINI SAS 2.1 GS-12-548

△ 14. EEPROM INFORMATION OF MSHD SIDE REFER TO FCI PRODUCT SPEC. GS-12-651.

△ 15. CABLE IS OPTIONAL, WHICH HAD BEEN QUALIFIED BY FCI AND MEET FCI PRODUCT SPEC. GS-12-651/548.

dr	Deborah Ingram	2011/03/17	projection 	MM ←→	size	A3	scale	1:1
eng	Tom Feng	2015/08/12			ecn no	ELX-N-21649-1		
chr	-	-			rel level	Released		
appr	Frank Mao	2015/08/12			product family	C&A		
		Mini SAS HD 4X TO Mini SAS 2.1		dwg no	10117771	rev	C	
www.fci.com		cat. no.	-	Product - Customer Drw		sheet 5 of 5		



Copyright FCI.



Компания «ЭлектроПласт» предлагает заключение долгосрочных отношений при поставках импортных электронных компонентов на взаимовыгодных условиях!

Наши преимущества:

- Оперативные поставки широкого спектра электронных компонентов отечественного и импортного производства напрямую от производителей и с крупнейших мировых складов;
- Поставка более 17-ти миллионов наименований электронных компонентов;
- Поставка сложных, дефицитных, либо снятых с производства позиций;
- Оперативные сроки поставки под заказ (от 5 рабочих дней);
- Экспресс доставка в любую точку России;
- Техническая поддержка проекта, помощь в подборе аналогов, поставка прототипов;
- Система менеджмента качества сертифицирована по Международному стандарту ISO 9001;
- Лицензия ФСБ на осуществление работ с использованием сведений, составляющих государственную тайну;
- Поставка специализированных компонентов (Xilinx, Altera, Analog Devices, Intersil, Interpoint, Microsemi, Aeroflex, Peregrine, Syfer, Eurofarad, Texas Instrument, Miteq, Cobham, E2V, MA-COM, Hittite, Mini-Circuits, General Dynamics и др.);

Помимо этого, одним из направлений компании «ЭлектроПласт» является направление «Источники питания». Мы предлагаем Вам помощь Конструкторского отдела:

- Подбор оптимального решения, техническое обоснование при выборе компонента;
- Подбор аналогов;
- Консультации по применению компонента;
- Поставка образцов и прототипов;
- Техническая поддержка проекта;
- Защита от снятия компонента с производства.



Как с нами связаться

Телефон: 8 (812) 309 58 32 (многоканальный)

Факс: 8 (812) 320-02-42

Электронная почта: org@eplast1.ru

Адрес: 198099, г. Санкт-Петербург, ул. Калинина, дом 2, корпус 4, литера А.