

NOTES
Bemerkungen

CONTACT AREA PRE SILVER MIN. 3µm
CANTILEVER SPRING PLAIN
Kontaktzone vorver Silber mit min. 3µm
Ueberfederer blank

CONTACT BODY NI-PLATING MIN. 0.5µm; CONTACT AREA PRE-GOLD MIN. 0.6µm
OVER NICKEL; CRIMP AREA PRE-TIN
CANTILEVER SPRING PLAIN
Kontaktkoerper vernickelt min. 0.5µm; Kontaktzone vorvergoldet min. 0.6µm ueber Nickel
Crimpzone vorverzinkt; Ueberfederer blank

--- IN THIS AREA CRACK SHAPING AT THE SURFACE PERMISSIBLE
In diesem Bereich Rissbildung in der Oberflaeche zulässig

PRE-TIN MIN. 1µm; CANTILEVER SPRING PLAIN
vorverzinkt min. 1µm; Ueberfederer blank

AWG 12 TXL 828905-1 OR / oder 282536-1
AWG 12 GXL 638865-1

ATTENTION! CONSTRUCTION OF THE CONTACT CAVITY IN THE AREA OF THE SINGLE WIRE SEAL IS $\phi 6.4^{+0.1}_{-0.05}$
Achtung! Die Kammer ist im Bereich der Einzeldichtung auf $\phi 6.4^{+0.1}_{-0.05}$ auszuliegen

PUNCHED WITH VOLATILIZING STAMPING-OIL
Gestanz mit verfluechtigendem Stanzoeel

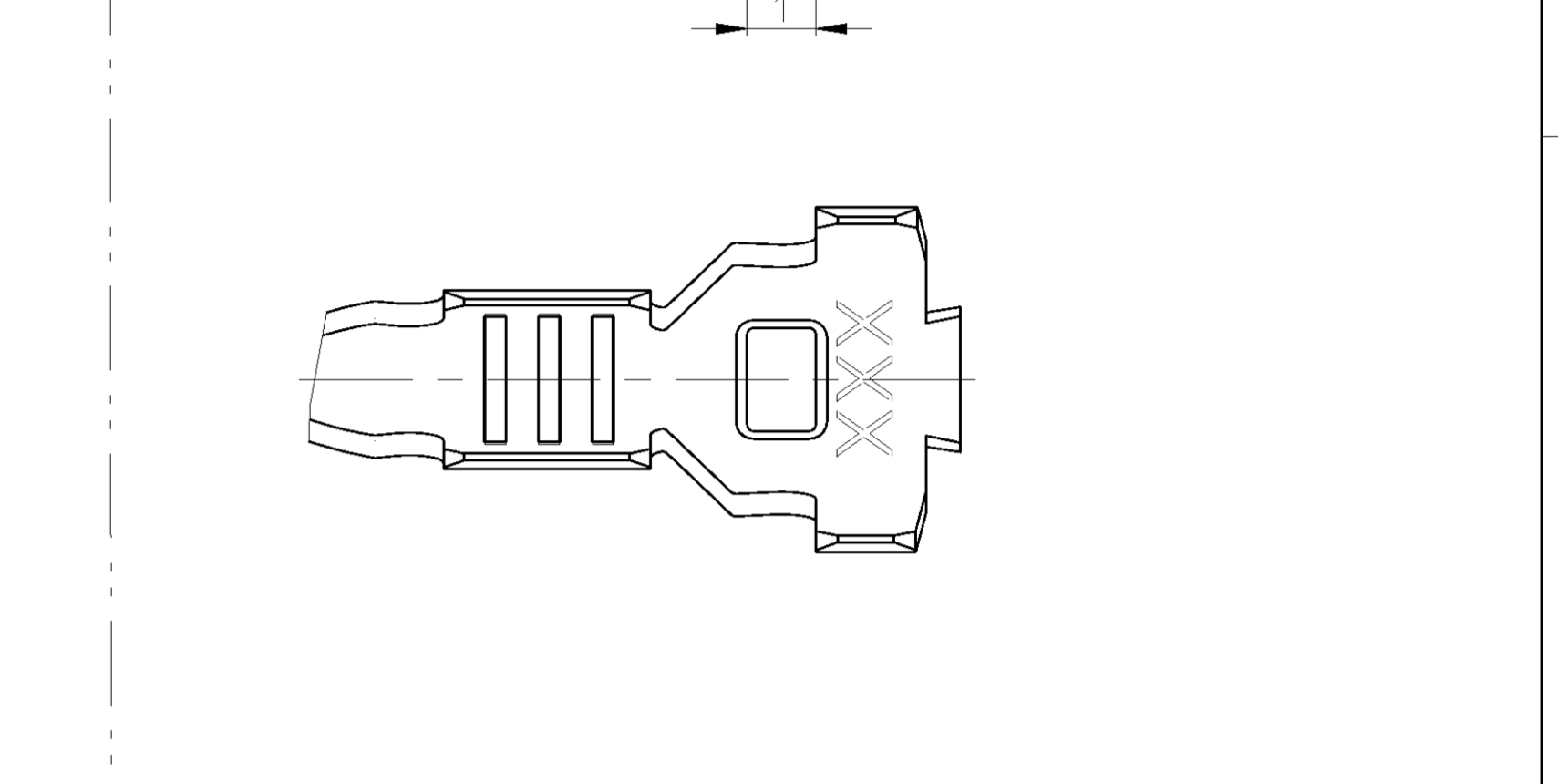
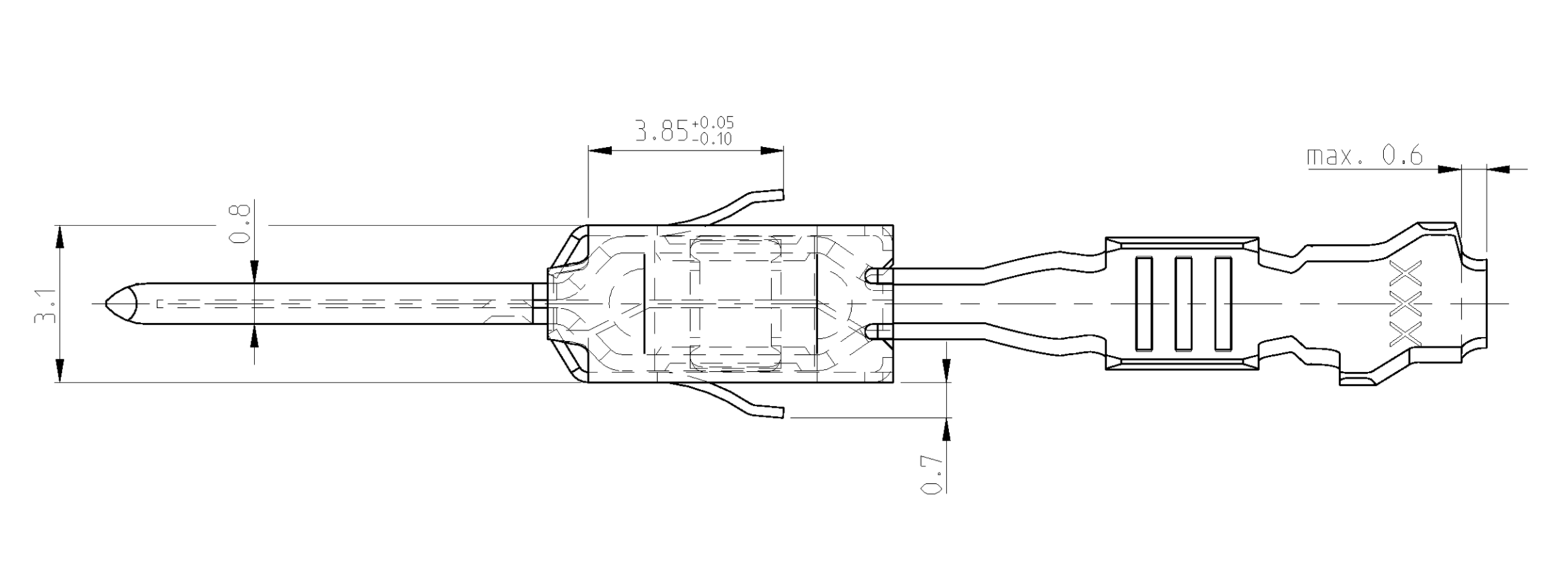

ORDER-NO.	DESIGN	MATERIAL	SURFACE	DGB	INSULATION	SEE / siehe SECTION A-A Schnitt A-A	SEE / siehe SECTION B-B Schnitt B-B	SEE / siehe WIRE CRIMP Drahtcrimp	SEE / siehe SECTION A-A Schnitt A-A	SEE / siehe SECTION B-B Schnitt B-B	APPLICATION TOOL	HAND TOOL	TE	TE					
1-1719504-2	A	1-1719503-2	4	CuSn4	AWG 12	E = 4.0 G = 4.2 D _{Dr} = 2.0	H = 5.3 K = 5.0 D = 3.6	AWG 12 = 2.0	-	-	MOC APPLICATOR	MATRIZE	1852291-3	3.5	6.0	7.6	26.8	828922-1	
3-968947-1	A	3-968966-1	6	CuSn0.20	FLR	E = 4.5 G = 4.7 D _{Dr} = 2.3	H = 6.2 K = 6.0 D = 4.3	4.0 mm ² = 2.25	DIMENSION SEE STRIP FORM Masse siehe Bandware		MOC APPLICATOR	MATRIZE	2-541537-2	4.3	6.9	8.5	28.5	828985 (Ø6.4)	828986-1
2-968947-2	A	2-968966-2	6	CuFe	FLR	E = 3.6 G = 3.8 D _{Dr} = 1.7	H = 5.3 K = 5.0 D = 3.6	2.5 mm ² = 1.88 2.0 mm ² = 1.73 1.5 mm ² = 1.58	E = 2.8 G = 3.9 D _{Dr} = 1.7	H = 4.8 K = 4.5 R = 2.8	MOC APPLICATOR	MATRIZE	734440-1	3.5	6.0	7.6	26.8	828905 (Ø5.0)	828922-1
1-968947-2	A	1-968966-2	6	CuSn4	FLR	E = 2.6 G = 2.9 D _{Dr} = 1.2	H = 5.0 K = 4.8 D = 3.3	1.0 mm ² = 1.36 0.75 mm ² = 1.27 0.5 mm ² = 1.18	E = 2.2 G = 2.9 D _{Dr} = 1.1	H = 4.6 K = 4.3 R = 2.3	MOC APPLICATOR	MATRIZE	734438-1	3.0	5.4	7.0	26.8	828904 (Ø5.0)	
1-968947-1	A	1-968966-1	6	CuSn4	FLR	E = 2.1 G = 2.1 D _{Dr} = 0.8	H = 4.7 K = 4.5 D = 3.2	0.5 mm ² = 1.12 0.35 mm ² = 1.05 0.2 mm ² = 0.98	E = 1.7 G = 2.15 D _{Dr} = 0.8	H = 4.2 K = 4.15 R = 2.4	MOC APPLICATOR	MATRIZE	539635-1 539737-2	2.5	4.9	6.5	26.8	828904 (Ø5.0)	
2-968947-1	A	2-968966-1	6	CuFe	FLR	E = 4.5 G = 4.7 D _{Dr} = 2.3	H = 5.7 K = 5.9 D = 3.3	4.0 mm ² = 2.25	E = 3.4 G = 4.7 D _{Dr} = 2.3	H = 4.6 K = 5.1 R = 2.6	MOC APPLICATOR	MATRIZE	539635-1 2-541534-2 539723-2	4.3	6.6	8.5	28.5	828922-1	
1-968946-1	A	1-968965-1	3	CuSn4	FLK	E = 3.6 G = 3.8 D _{Dr} = 1.7	H = 5.5 K = 5.7 D = 3.2	2.5 mm ² = 1.88 2.0 mm ² = 1.73 1.5 mm ² = 1.58	E = 2.8 G = 3.9 D _{Dr} = 1.7	H = 4.2 K = 5.1 R = 2.4	MOC APPLICATOR	MATRIZE	734447-3	3.6	5.2	8.9	28.6		
2-962843-2	C	2-963747-2	1	CuFe	FLR	E = 3.6 G = 3.8 D _{Dr} = 1.7	H = 4.3 K = 4.5 D = 2.6	2.5 mm ² = 1.88 2.0 mm ² = 1.73 1.5 mm ² = 1.58	E = 2.8 G = 3.9 D _{Dr} = 1.7	H = 3.6 K = 4.1 R = 2.1	MOC APPLICATOR	MATRIZE	734417-2	3.6	5.2	8.2	27.9		
2-962843-1	C	2-963747-1	1	CuSn4	FLR	E = 2.6 G = 2.8 D _{Dr} = 1.1	H = 3.2 K = 3.4 D = 1.8	1.0 mm ² = 1.36 0.75 mm ² = 1.27 0.5 mm ² = 1.18	E = 2.2 G = 2.8 D _{Dr} = 1.1	H = 2.8 K = 3.0 R = 1.6	MOC APPLICATOR	MATRIZE	734417-1	3.0	4.6	7.0	26.7		
1-962843-1	C	1-963747-1	1	CuSn4	FLR	E = 2.1 G = 2.1 D _{Dr} = 0.8	H = 2.9 K = 2.9 D = 1.4	0.5 mm ² = 1.12 0.35 mm ² = 1.05 0.2 mm ² = 0.98	E = 1.7 G = 2.1 D _{Dr} = 0.8	H = 2.5 K = 2.5 R = 1.4	MOC APPLICATOR	MATRIZE	734538-1	2.5	3.7	5.8	25.5		
2-962842-3	E	-	1	CuFe	FLR	E = 3.6 G = 3.8 D _{Dr} = 1.7	H = 4.3 K = 4.5 D = 2.6	2.5 mm ² = 1.88 2.0 mm ² = 1.73 1.5 mm ² = 1.58	E = 2.8 G = 3.9 D _{Dr} = 1.7	H = 3.6 K = 4.1 R = 2.1	MOC APPLICATOR	MATRIZE	734417-2	3.6	5.2	8.2	27.9		
2-962842-2	F	-	1	CuFe	FLR	E = 2.6 G = 2.8 D _{Dr} = 1.1	H = 3.2 K = 3.4 D = 1.8	1.0 mm ² = 1.36 0.75 mm ² = 1.27 0.5 mm ² = 1.18	E = 2.2 G = 2.8 D _{Dr} = 1.1	H = 2.8 K = 3.0 R = 1.6	MOC APPLICATOR	MATRIZE	734417-1	3.0	4.6	7.0	26.7		
2-962841-2	F	-	1	CuFe	FLR	E = 2.6 G = 2.8 D _{Dr} = 1.1	H = 3.2 K = 3.4 D = 1.8	1.0 mm ² = 1.36 0.75 mm ² = 1.27 0.5 mm ² = 1.18	E = 2.2 G = 2.8 D _{Dr} = 1.1	H = 2.8 K = 3.0 R = 1.6	MOC APPLICATOR	MATRIZE	734417-1	3.0	4.6	7.0	26.7		
1-962841-1	F	1-963745-1	1	CuSn4	FLR	E = 2.1 G = 2.1 D _{Dr} = 0.8	H = 2.9 K = 2.9 D = 1.4	0.5 mm ² = 1.12 0.35 mm ² = 1.05 0.2 mm ² = 0.98	E = 1.7 G = 2.1 D _{Dr} = 0.8	H = 2.5 K = 2.5 R = 1.4	MOC APPLICATOR	MATRIZE	734538-1	2.5	3.7	5.8	25.5		
2-963860-3	B	-	2	CuFe	FLR	E = 2.1 G = 2.1 D _{Dr} = 0.8	H = 2.9 K = 2.9 D = 1.4	0.5 mm ² = 1.12 0.35 mm ² = 1.05 0.2 mm ² = 0.98	E = 1.7 G = 2.1 D _{Dr} = 0.8	H = 2.5 K = 2.5 R = 1.4	MOC APPLICATOR	MATRIZE	734538-1	2.5	3.7	5.8	25.5		

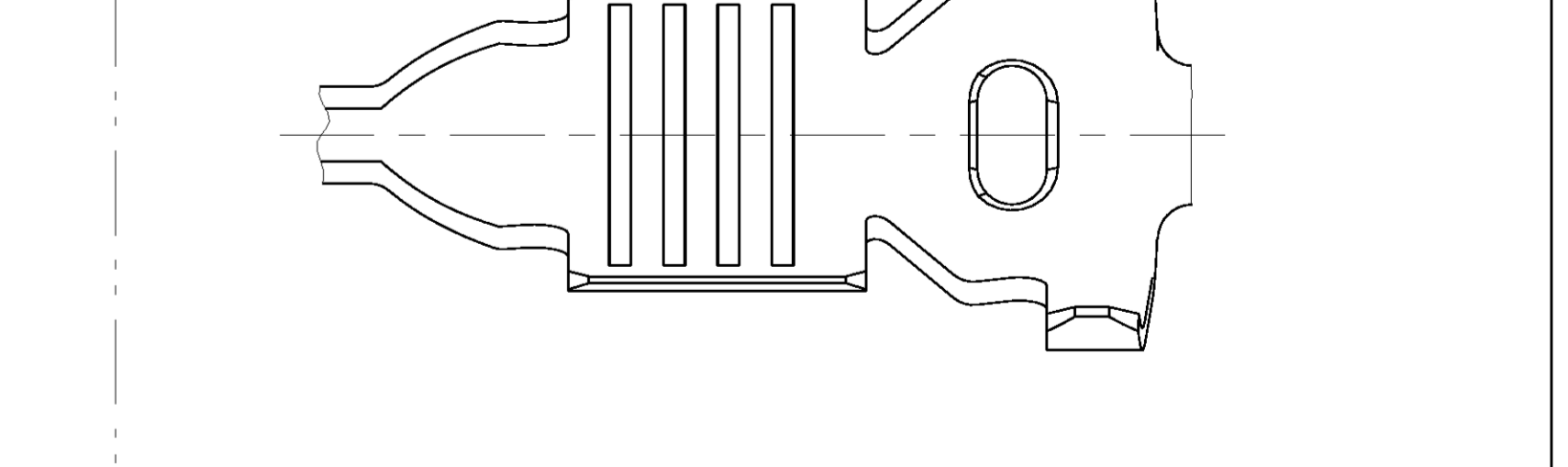
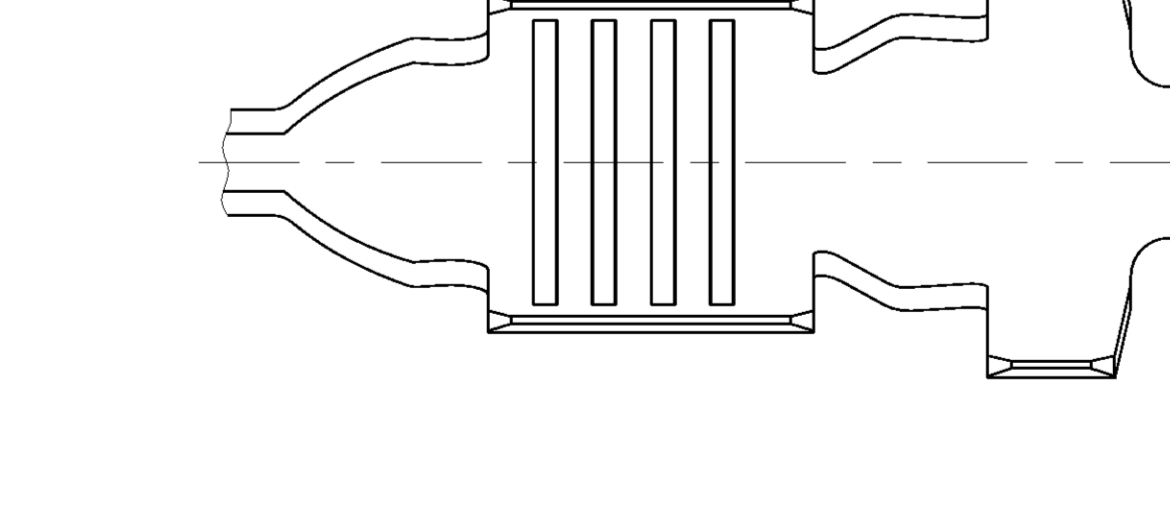
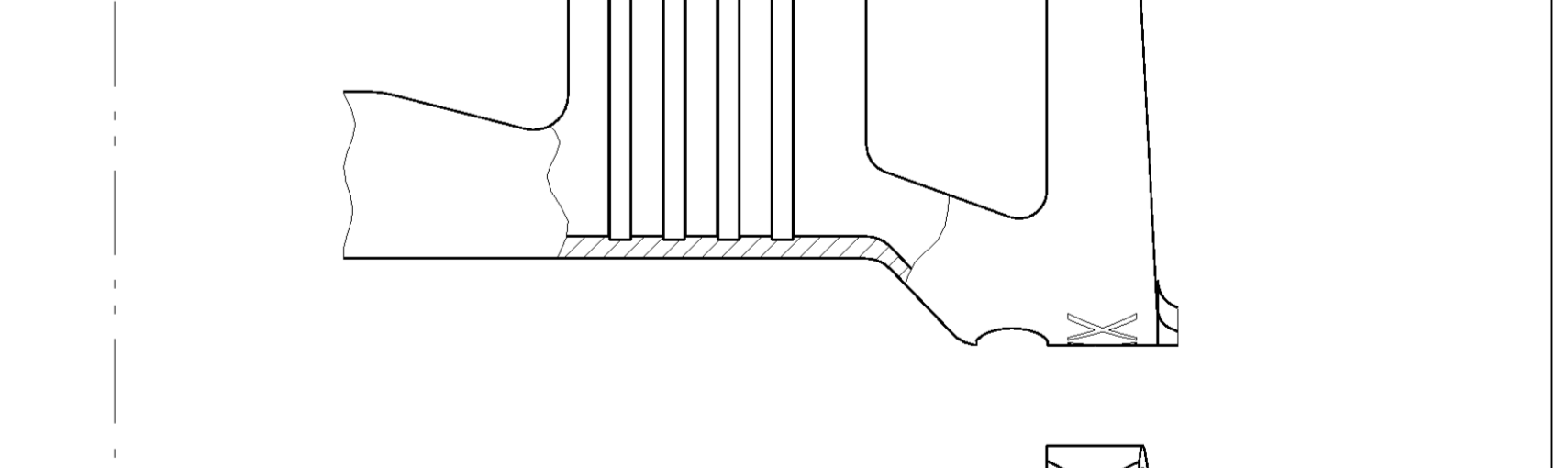
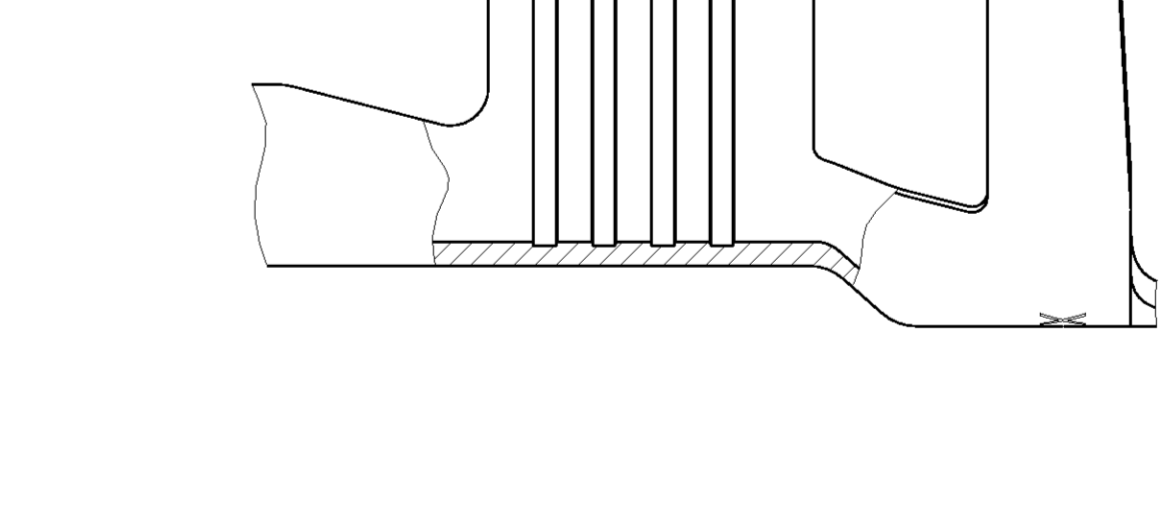
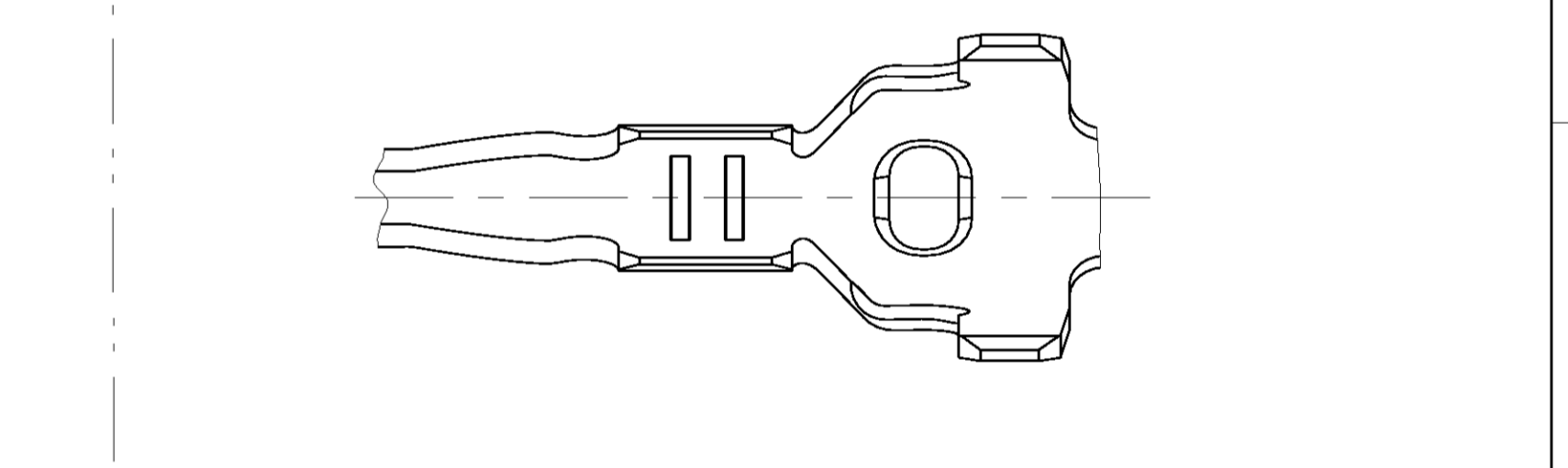
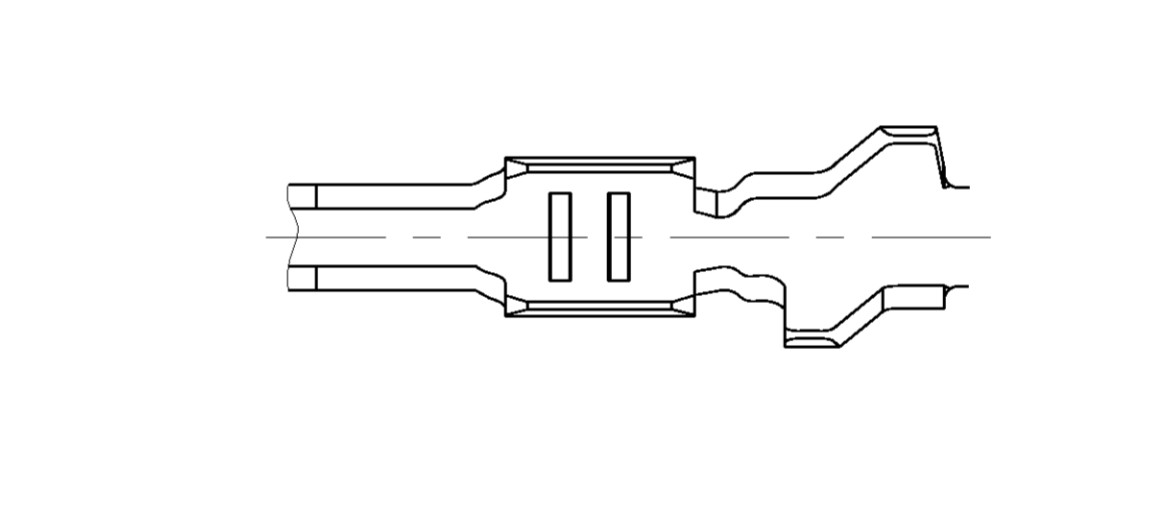
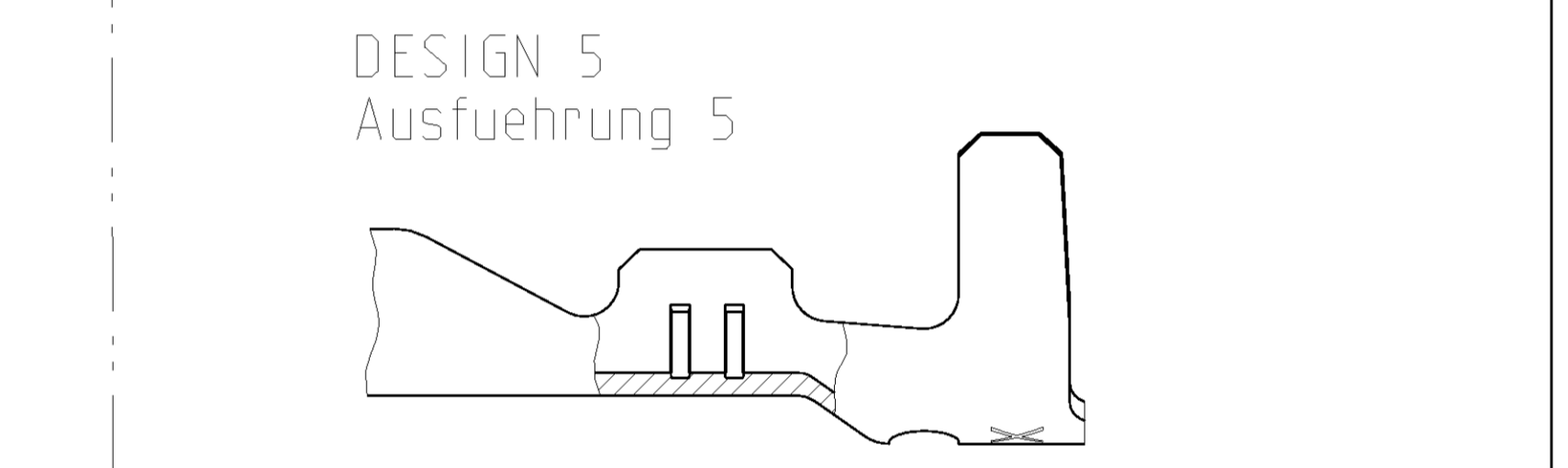
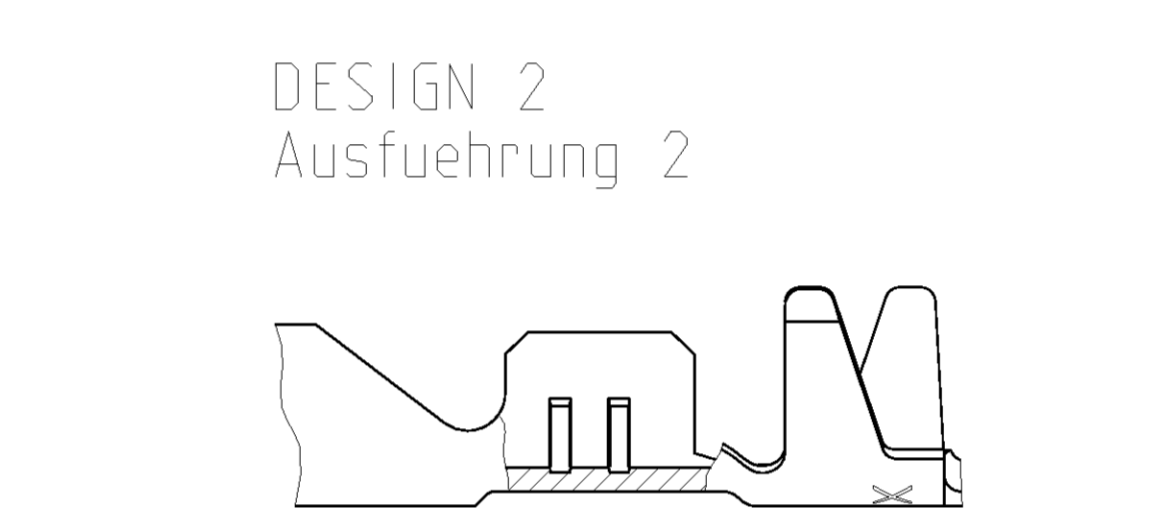

TE	TE	STRIP FORM	WIRE CRIMP	LOOSE PIECE	APPLICATION TOOL	HAND TOOL	TE	TE
ORDER-NO.	ORDER-NO.	WIRE CRIMP	WIRE CRIMP	WIRE CRIMP	ANSCHLAGWERKZEUG	HANDZANGE	ORDER-NO.	ORDER-NO.
STRIPFORM	LOOSE PIECE	Drahtcrimp	Drahtcrimp	Drahtcrimp	Anschlagwerkzeug	Handzange	SEALING PLUG	BLINDSTOPFEN
Bandware	Einzelausfuehrung	Drahtcrimp	Drahtcrimp	Einzelausfuehrung	Ausdruckwerkzeug	Handzange	Blindstopfen	Blindstopfen
					EXTRACTION TOOL Ausdruckwerkzeug No. 968107-1			

THIS DRAWING IS A CONTROLLED DOCUMENT.

DATE: 14 JUN 1999

DESIGNED BY: J. Gerlach

DRAWN BY: H. Bleicher

SCALE: 1:1

PRODUCT GROUP: TE Connectivity

PRODUCT GROUP DRAWING FOR TAB 2.8x0.8

PRODUCT GROUP ZEICHNUNG FÜR FLACHSTECKER 2.8x0.8

STANDARD: 108-18063

APPLICATION SPEC: 114-18051

WEIGHT: 0.012

CUSTOMER: Drawing

SCALE: 10:1

SHEET 1 OF 1

REV. 1

DATE: 10/1/98



Компания «ЭлектроПласт» предлагает заключение долгосрочных отношений при поставках импортных электронных компонентов на взаимовыгодных условиях!

Наши преимущества:

- Оперативные поставки широкого спектра электронных компонентов отечественного и импортного производства напрямую от производителей и с крупнейших мировых складов;
- Поставка более 17-ти миллионов наименований электронных компонентов;
- Поставка сложных, дефицитных, либо снятых с производства позиций;
- Оперативные сроки поставки под заказ (от 5 рабочих дней);
- Экспресс доставка в любую точку России;
- Техническая поддержка проекта, помощь в подборе аналогов, поставка прототипов;
- Система менеджмента качества сертифицирована по Международному стандарту ISO 9001;
- Лицензия ФСБ на осуществление работ с использованием сведений, составляющих государственную тайну;
- Поставка специализированных компонентов (Xilinx, Altera, Analog Devices, Intersil, Interpoint, Microsemi, Aeroflex, Peregrine, Syfer, Eurofarad, Texas Instrument, Miteq, Cobham, E2V, MA-COM, Hittite, Mini-Circuits, General Dynamics и др.);

Помимо этого, одним из направлений компании «ЭлектроПласт» является направление «Источники питания». Мы предлагаем Вам помощь Конструкторского отдела:

- Подбор оптимального решения, техническое обоснование при выборе компонента;
- Подбор аналогов;
- Консультации по применению компонента;
- Поставка образцов и прототипов;
- Техническая поддержка проекта;
- Защита от снятия компонента с производства.



Как с нами связаться

Телефон: 8 (812) 309 58 32 (многоканальный)

Факс: 8 (812) 320-02-42

Электронная почта: org@eplast1.ru

Адрес: 198099, г. Санкт-Петербург, ул. Калинина, дом 2, корпус 4, литера А.