

**NEW**

# Micro-USB connectors meeting requirements of USB 2.0 Standard

## ZX Series

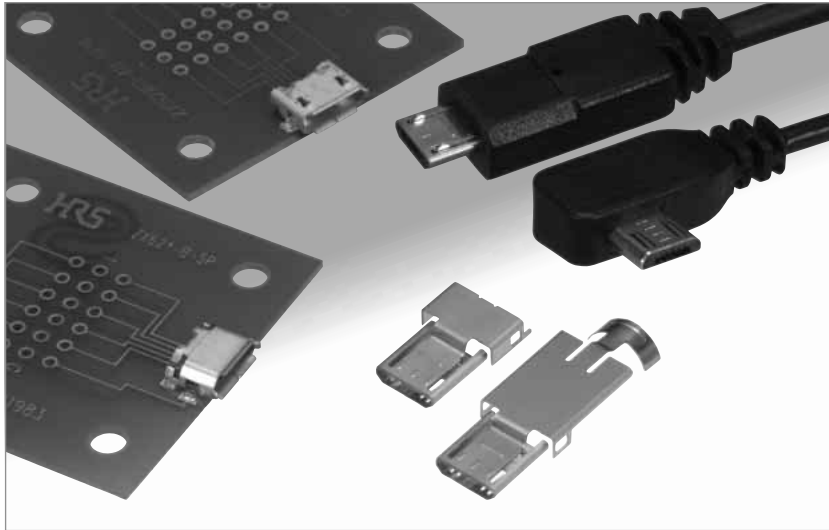

Note: Contact us to ascertain whether a TID number has been acquired for an individual product.

### Overview

Extremely small high reliability connectors complying with physical, electrical and environmental requirements of Micro-USB standard (USB 2.0).

Receptacles and plugs are available in a wide variety of mounting and termination configurations, permitting their use in various applications.

### Features

#### 1. Size reduction

Compared with the standard Mini-B connectors, the size of ZX connectors is reduced by approximately 60% while still allowing a high-speed data transfer of 480 Mbps, specified in USB 2.0.

#### 2. Receptacle styles

Two interface configurations: Micro-B and Micro-AB in standard, mid-mount and reverse mounting styles. SMT and through-hole (shell) PC board terminations

#### 3. Plug styles

Corresponding to the receptacle styles, two interface configurations: Micro-B and Micro-A, with direct wire or PCB wire soldering. Several plug styles can be used for data transmission, earphone or charging applications.

#### 4. High durability

Unique contact and lock configuration assures high durability while maintaining easy insertion / disconnection. Fully mated condition (when mated with corresponding HRS connector) is confirmed by a definite tactile sensation

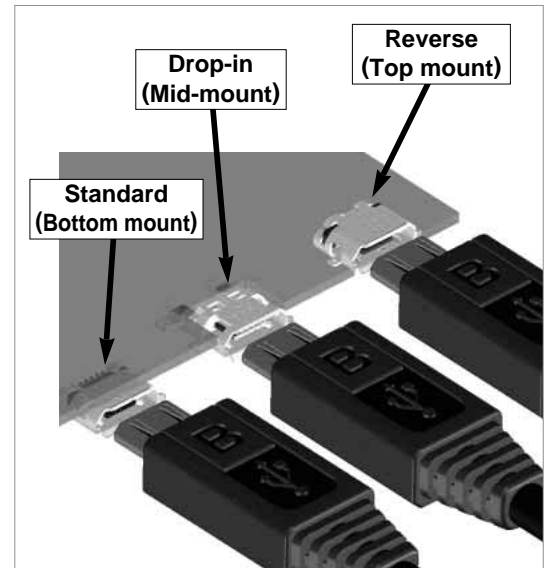

### USB 2.0 Hi-Speed (480 Mbps)

Eye pattern measurement results:  
Measured with USB 2.0 cable 2.4 m long

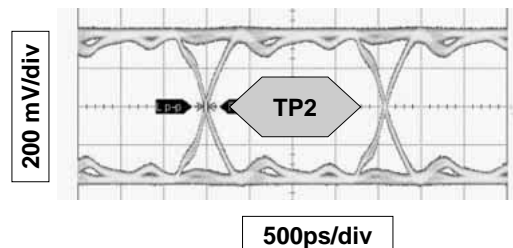

## ■ Specifications

Ratings	Current rating	1 A (per contact) or 1.8 A (contacts No. 1 and 5) and 0.5 A (contacts No. 2, 3, and 4)	Voltage rating	30 V AC
			Operating temperature range	-30°C to +85 °C (Note1)
			Storage temperature range	-30 °C to +85°C

Item	Specification	Conditions
1. Contact resistance	30 mΩ max.	100 mA
2. Withstanding voltage	No flashover or insulation breakdown	100 V AC / 1 minute
3. Capacitance	2 pF max.	Between adjacent contacts at 1,000 Hz (AC voltage)
4. Durability	Contact resistance: Rise from initial value of 10 mΩ max.	10,000 cycles
5. Total insertion/removal force	Insertion force: 35 N max., Removal force: 8 N min.	Mated with corresponding connector

Note1: Includes temperature rise caused by current flow.

Note2: Information contained in this catalog represents general requirements for this Series. Contact us for the drawings and specifications for a specific part number shown.

## ■ Materials

### ● Receptacles

Part	Material	Finish	Remarks
Insulator	LCP	Micro-B: Black, Micro-AB: Gray	UL94V-0
Contacts	Copper alloy	Selective gold plated	_____
Shell	Stainless steel	Tin alloy plating	_____

### ● Plugs

Part	Material	Finish	Remarks
Insulator	Synthetic resin	Micro-A: White, Micro-B: Black	UL94V-0
Contacts	Copper alloy	Selective gold plated	_____
Lock spring	Stainless steel	_____	_____
Shell	Stainless steel	Nickel plated or unfinished	_____

## ■ Ordering information

### ● Receptacles

**ZX 62 RD - B - 5 P \* 8**  
① ② ③ ④ ⑤ ⑥ ⑦ ⑧

### ● Plugs

**ZX 40 - B - 5 S \* - UNIT**  
① ② ④ ⑤ ⑥ ⑦ ⑨

**ZX 40 - B - SLDA**  
① ② ④ ⑨

① Series name		ZX
② Termination style		10's: Right-angle PCB wire, SMT 20's: Straight, PCB wire 40's: Direct wire 60's: Right-angle, PCB wire 80's: Cradle SMT
③ Board mounting style (Receptacles)	Blank D R RD M	Standard (Bottom mount) Standard (Bottom mount) through hole Reverse (Top mount) Reverse (Top mount) through hole Drop-in (Mid-mount)
④ Mating side configuration	A B AB	Micro-A Micro-B Micro-AB
⑤ Number of contacts		5
⑥ Contact type	P S	Receptacle- Male Plug - Female
⑦ Serial No.		
⑧ Shell termination style – Receptacles	Blank 8	SMT Through hole (solder tab length: 0.8mm)
⑨ Components-plugs	UNIT SLD*	Assembly (Insulator/contact/lock) Cover (Note 1)

Note 1: Classifiers such as A, B, and C are entered for \*.

## ■ Product Styles Table

Interface	Receptacle	Plug
Micro-A		
Micro-B		
Micro-AB		

## ■ Configurations

	Mating side configuration	Application	Mounting, termination styles/wire attachment	Part Number	3D Image	Page
R e c e p t a c l e s	Micro-B	Standard	SMT	ZX62-B-5PA(11)		4
			SMT + DIP	ZX62D-B-5PA8		4
		Reverse	SMT	ZX62R-B-5P		5
		Drop-in	SMT	ZX62M-B-5P(02)		5
	Micro-AB	Standard	SMT	ZX62-AB-5PA(11)		6
			SMT + DIP	ZX62D-AB-5P8		6
		Reverse	SMT	ZX62R-AB-5P		7
			SMT + DIP	ZX62RD-AB-5P8		7
P l u g s	Micro-B	Data	Direct wire soldering	Assembly (insulator/contacts/lock) :ZX40-B-5S-UNIT(12) Cover-top :ZX40-B-SLDA Cover-bottom :ZX40-SLDB		9 and 10
			PCB wire soldering (right angle, through hole)	Assembly (insulator/contacts/lock) :ZX10-B-5S-UNIT(12) Cover-top :ZX10-B-SLDA Cover-bottom :ZX10-SLDB(3.3)		11 and 12
		Earphone	PCB wire soldering (straight, through hole)	Assembly (insulator/contacts/lock) :ZX20-B-5S-UNIT(12) Cover :ZX20-B-SLDC		13
		Charging	PCB wire soldering (SMT)	Assembly (insulator/contacts/lock) :ZX64-B-5S-UNIT(14) Cover-top :ZX64-B-SLDA Cover-bottom :ZX64-SLDB		14 and 15
		Charging Earphone	PCB wire soldering (SMT)	Assembly (insulator/contacts/lock) :ZX64-B-5S-UNIT(14) Cover :ZX64-B-SLDC		14 and 16
	Micro-A	Data	Direct wire soldering	Assembly (insulator/contacts/lock) :ZX40-A-5S-UNIT Cover-top :ZX40-A-SLDA Cover-bottom :ZX40-SLDB		17 and 18
C r a d l e s	Micro-B	Cradle	SMT + DIP	ZX80-B-5S	With lock	19
				ZX80-B-5SA	Without lock	19

Note: 1. Part numbers in the Plugs section of the above table list the Assembly (insulator/contacts/locks) and the corresponding Shields/Covers.

Note: 2. Optional Printed Circuit boards for the Plugs are shown for reference only. Not supplied with applicable connectors.

Note: 3. The color of the insulators body in the Assembly (insulator/contacts/lock) shown in the 3D Image column above is blue for clarity. Refer to the Materials (Page 2) for correct colors.

## ■ Receptacles

### ● Micro B - Standard (Bottom mount), Shell SMT

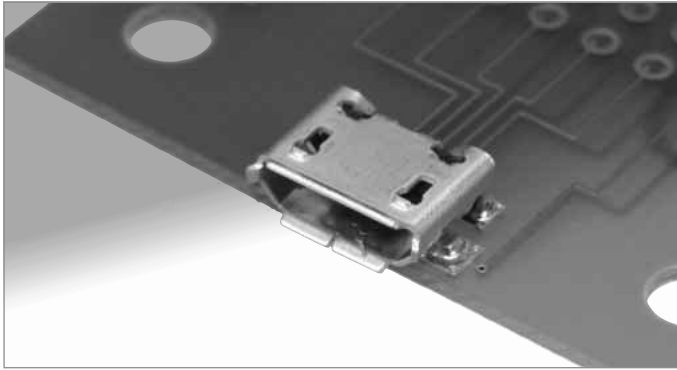

Part Number	CL No.	Packaging
ZX62-B-5PA(11)	242-0033-8-11	3,500 pieces per reel

### ■ Recommended PCB mounting pattern

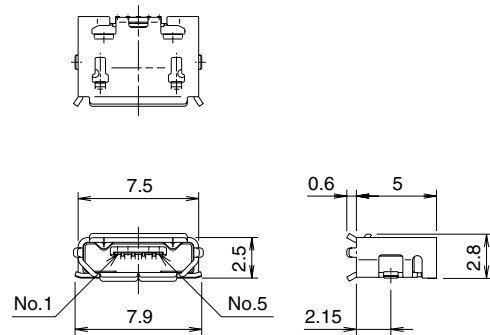
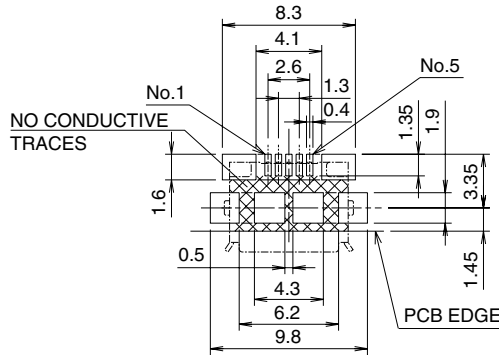

### ● Micro B - Standard (Bottom mount), Shell through hole

All dimensions: mm

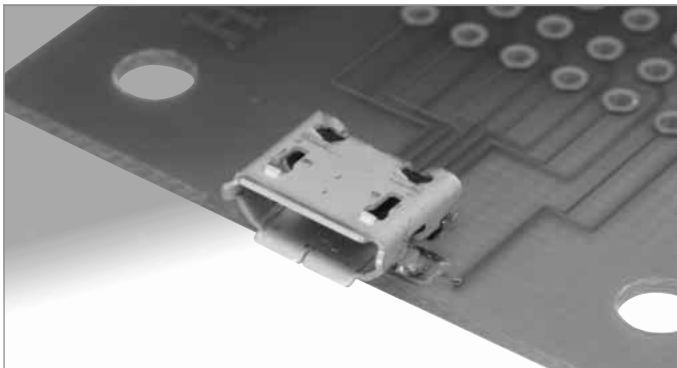

Part Number	CL No.	Packaging
ZX62D-B-5PA8	242-0056-3	2,000 pieces per reel

### ■ Recommended PCB mounting pattern

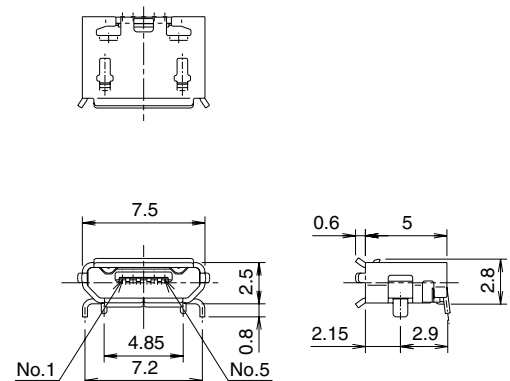
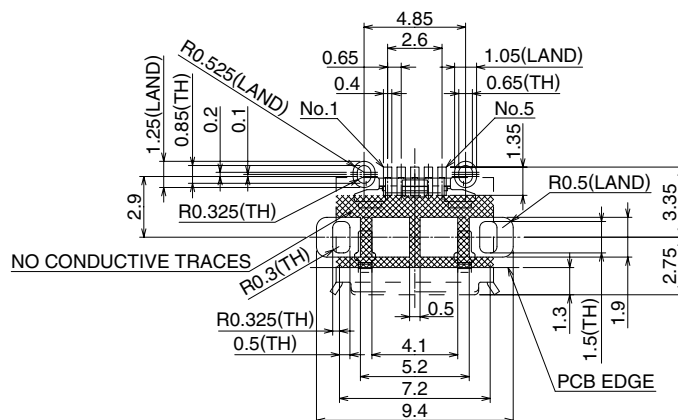

All dimensions: mm

## ■ Receptacles

### ● Micro B - Reverse (Top mount) Shell SMT

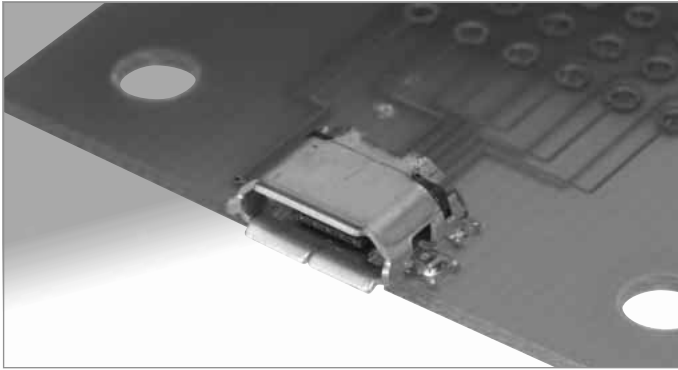

Part Number	CL No.	Packaging
ZX62R-B-5P	242-0028-8	2,000 pieces per reel

### ■ Recommended PCB mounting pattern

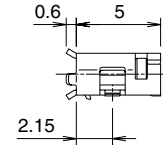
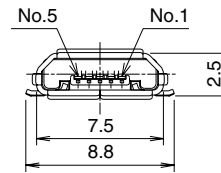
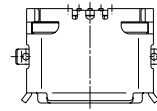
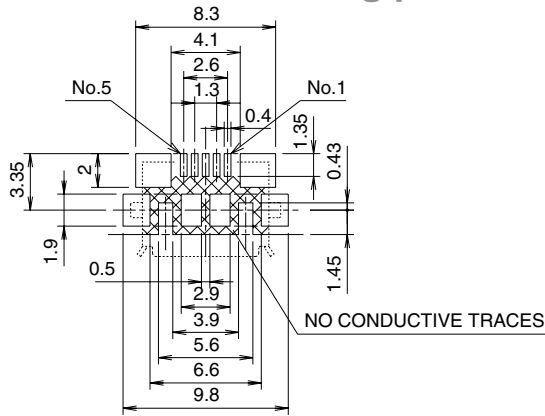

### ● Micro B - Drop-in (Mid-mount), Shell SMT

All dimensions: mm

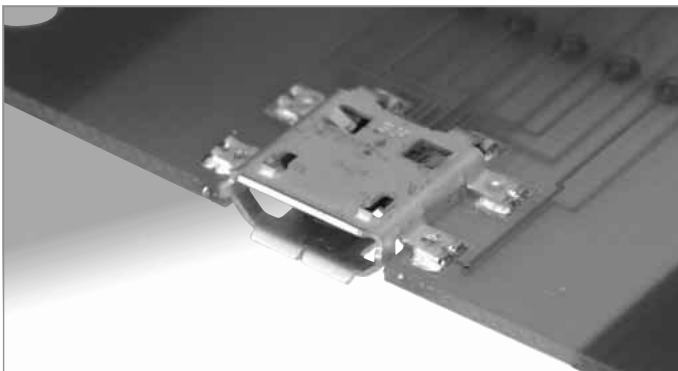

Part Number	CL No.	Packaging
ZX62M-B-5P(02)	242-0024-7-02	2,000 pieces per reel

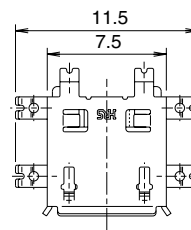

### ■ Recommended PCB mounting pattern

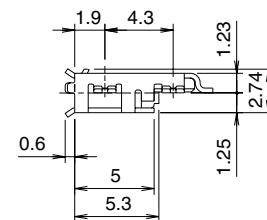
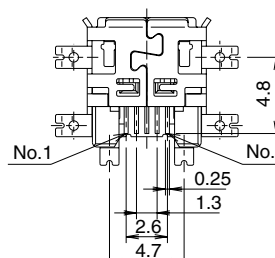
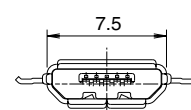
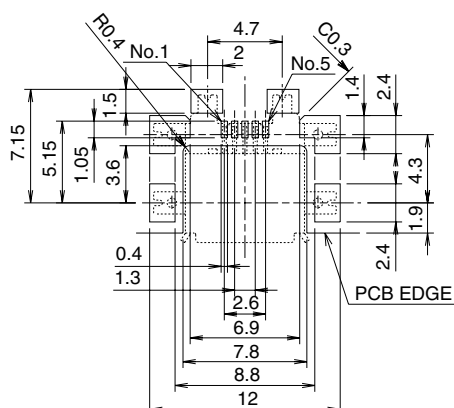

All dimensions: mm

## Receptacles

### Micro AB - Standard (Bottom mount), Shell SMT

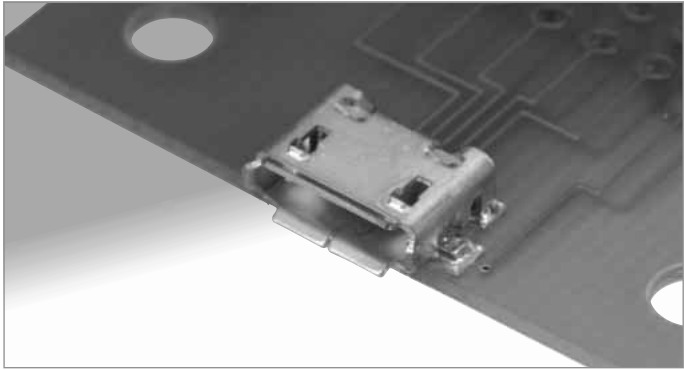

Part Number	CL No.	Packaging
ZX62-AB-5PA(11)	242-0045-7-11	3,500 pieces per reel

### Recommended PCB mounting pattern

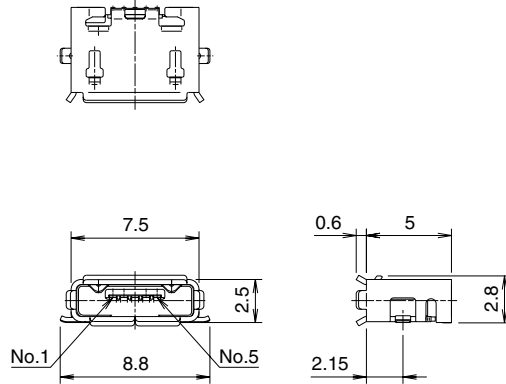
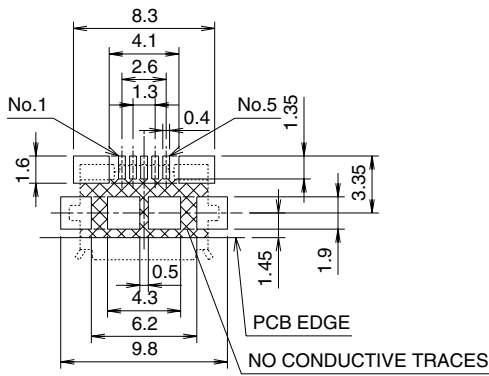

### Micro AB - Standard (Bottom mount), Shell through hole

All dimensions: mm

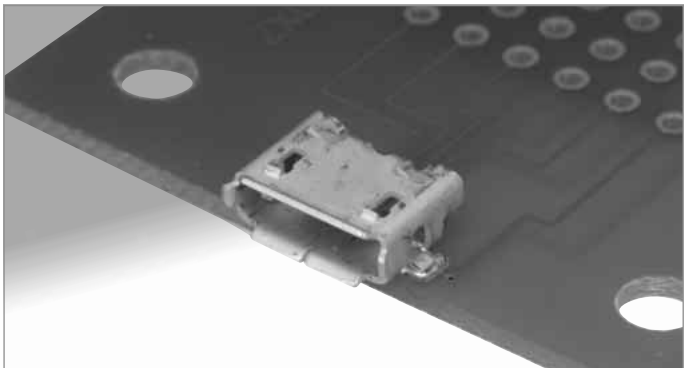

Part Number	CL No.	Packaging
ZX62D-AB-5P8	242-0027-5	2,000 pieces per reel

### Recommended PCB mounting pattern

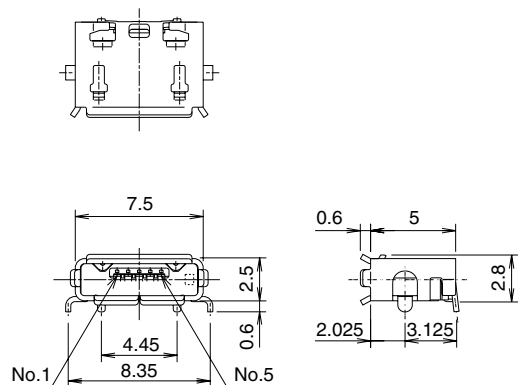
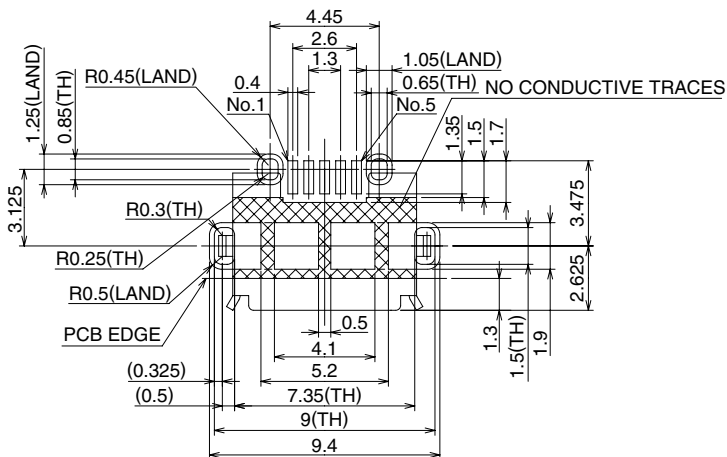

All dimensions: mm

## ■ Receptacles

### ● Micro AB - Reverse (Top mount), Shell SMT

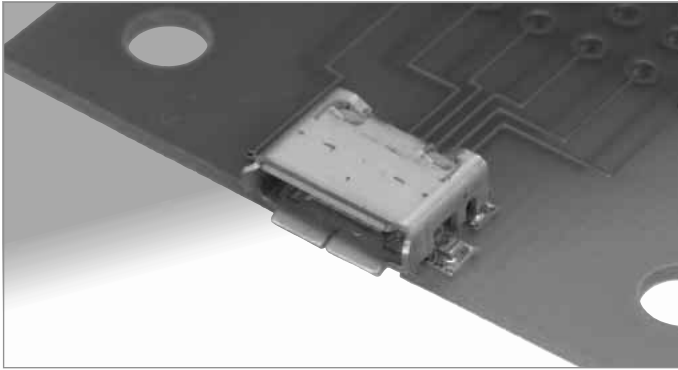

Part Number	CL No.	Packaging
ZX62R-AB-5P	242-0035-3	2,000 pieces per reel

### ■ Recommended PCB mounting pattern

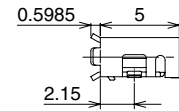
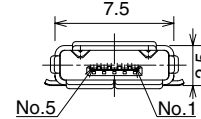
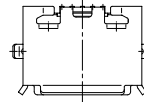
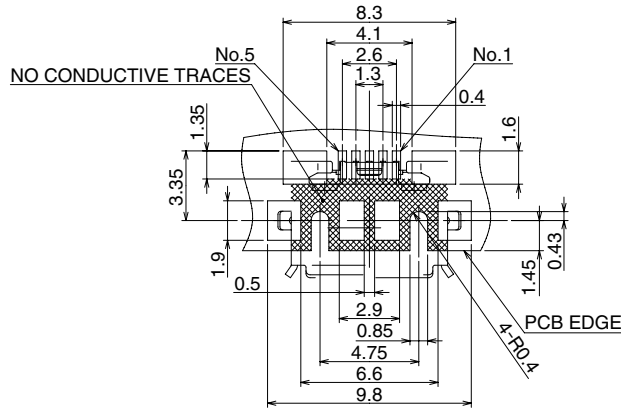

### ● Micro AB - Reverse (Top mount), Shell through hole

All dimensions: mm

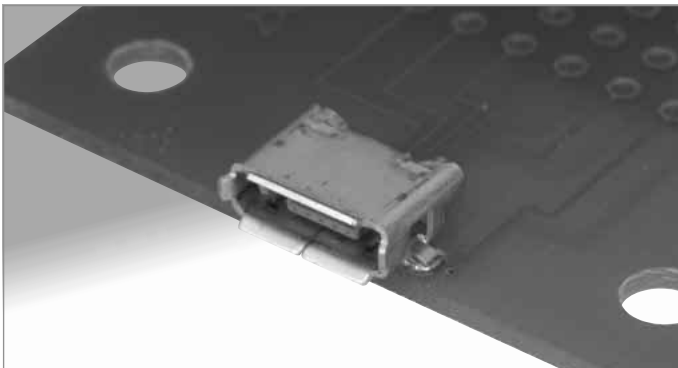





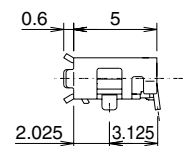
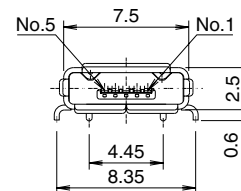
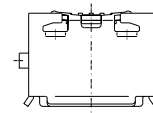
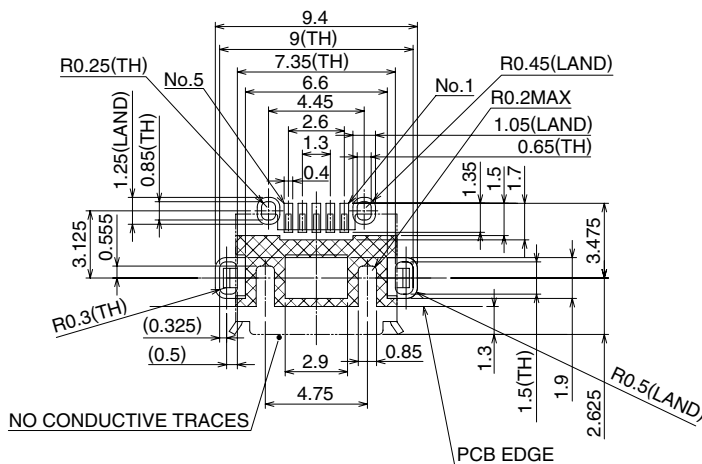



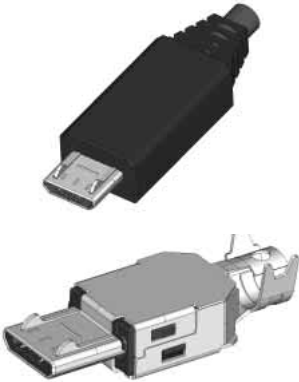
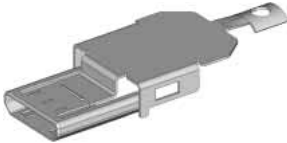

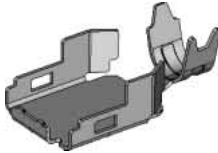

Part Number	CL No.	Packaging
ZX62RD-AB-5P8	242-0025-0	2,000 pieces per reel

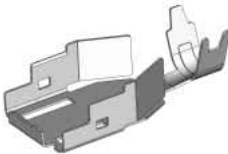
### ■ Recommended PCB mounting pattern

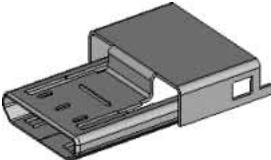

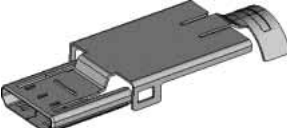
All dimensions: mm

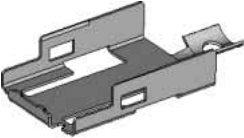
Plugs – assembled (not-terminated, without overmold)	Components
<p data-bbox="236 165 692 204"><b>ZX40 - Direct wire soldering</b></p> 	 <p data-bbox="1235 242 1469 306"><b>ZX40-*-SLDA</b> Cover-top</p>  <p data-bbox="1235 370 1469 476"><b>ZX40-*-5S-UNIT</b> Assembly (insulator/contacts/lock) *No PCB required</p>  <p data-bbox="1235 512 1469 576"><b>ZX40-SLDB</b> Cover-bottom</p>
<p data-bbox="236 638 692 676"><b>ZX10 - PCB wire soldering</b></p> 	 <p data-bbox="1235 715 1469 778"><b>ZX10-B-SLDA</b> Cover-top</p>  <p data-bbox="1235 842 1469 949"><b>ZX10-B-5S-UNIT</b> Assembly (insulator/contacts/lock) *SMT PCB termination</p>  <p data-bbox="1235 985 1469 1049"><b>ZX10-SLDB</b> Cover-bottom</p>
<p data-bbox="236 1117 692 1155"><b>ZX20 - PCB wire soldering</b></p> 	 <p data-bbox="1235 1215 1469 1278"><b>ZX20-*-SLDC</b> Cover</p>  <p data-bbox="1235 1364 1469 1491"><b>ZX20-*-5S-UNIT</b> Assembly (insulator/contacts/lock) *Straight through hole PCB termination</p>
<p data-bbox="236 1527 692 1566"><b>ZX64 - PCB wire soldering</b></p> 	 <p data-bbox="1235 1602 1469 1666"><b>ZX64-*-SLDA</b> Cover-top</p>  <p data-bbox="1235 1736 1469 1864"><b>ZX64-*-5S-UNIT</b> Assembly (insulator/contacts/lock) *Right angle through hole PCB termination</p>  <p data-bbox="1235 1921 1469 1985"><b>ZX64-SLDB</b> Cover-bottom</p>



## Plugs

### ● Micro B - Assembly (insulator/contacts/lock) – Direct wire soldering



Part Number	CL No.
ZX40-B-5S-UNIT(12)	242-0002-4-12

Contact HRS for Cable Termination Procedure Manual.

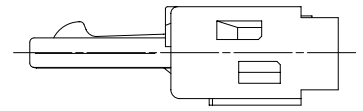
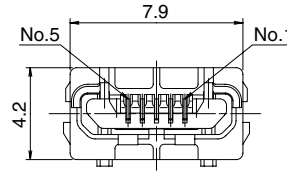
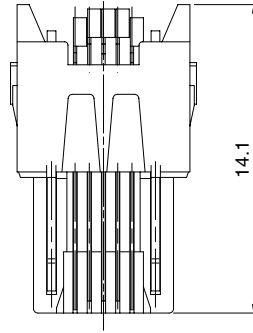

All dimensions: mm

### ● Micro B - Component, Cover-top - Direct wire soldering

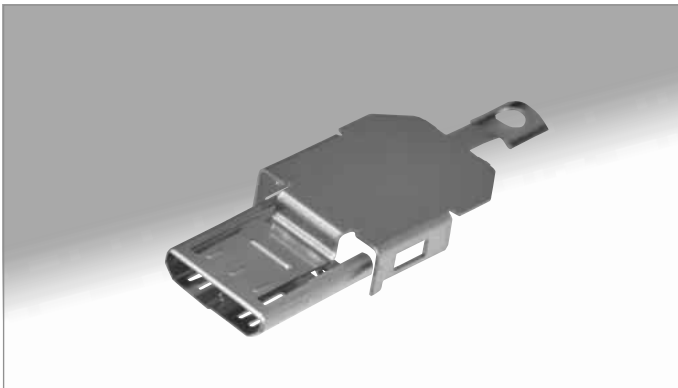

Part Number	CL No.	Packaging
ZX40-B-SLDA	242-0003-7	4,000 pieces per reel

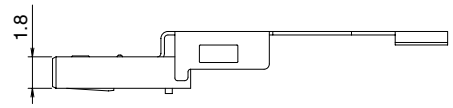
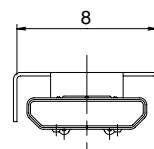
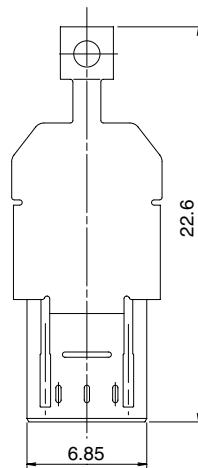

All dimensions: mm

## ■ Plugs

### ● Micro A, Micro B - Component, Cover-bottom - Direct wire soldering

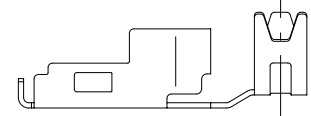
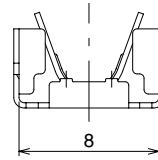
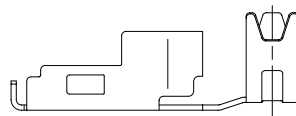
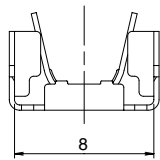
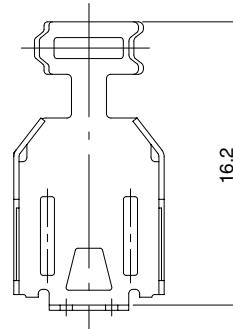
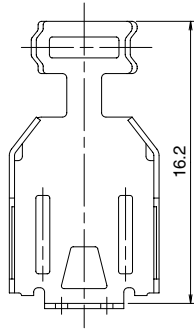
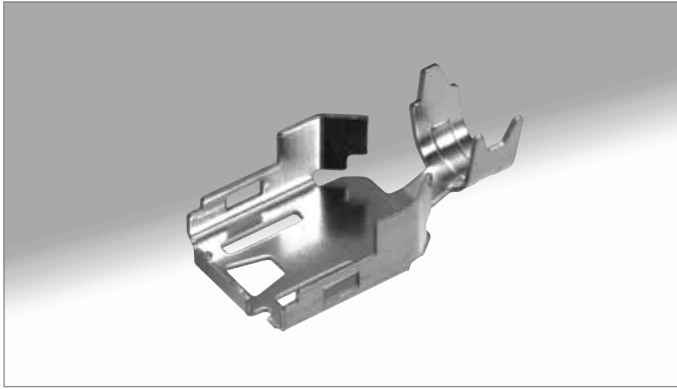

All dimensions: mm

ZX40-SLDB

ZX40-SLDB(3.3)

Part Number	CL No.	Packaging	Cable dia.
ZX40-SLDB	242-0004-0	4,000 pieces per reel	φ3.8
ZX40-SLDB(3.3)	242-0023-4		φ3.3

### ● Assembled

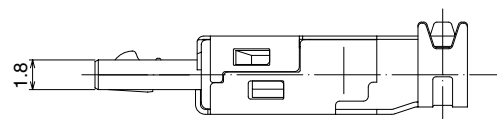
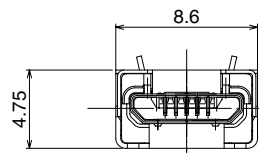
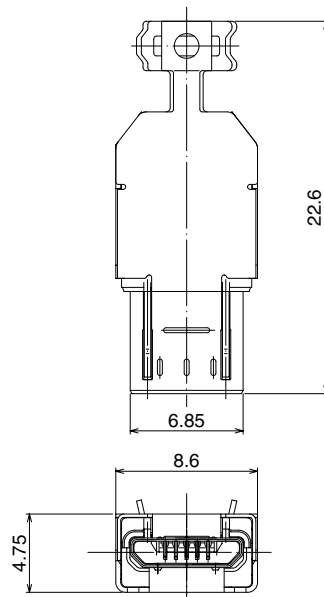

All dimensions: mm

## Plugs

### ● Micro B - Assembly (insulator/contacts/lock) - Right angle through hole PCB wire soldering (non-direct)



Part Number	CL No.	Packaging
ZX10-B-5S-UNIT(12)	242-0030-0-12	1,500 pieces per reel

Contact HRS for Cable Termination Procedure Manual.



#### PCB mounting pattern

\*PCB required (not supplied)  
 Max. thickness: 0.6mm

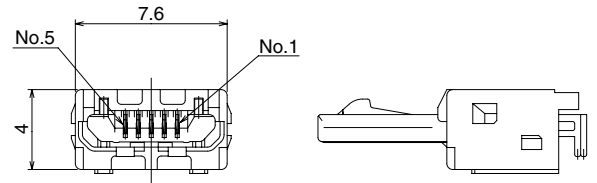
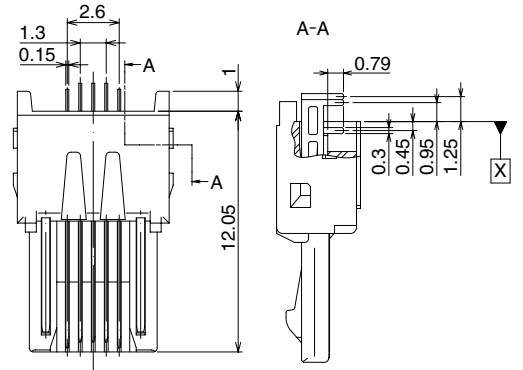
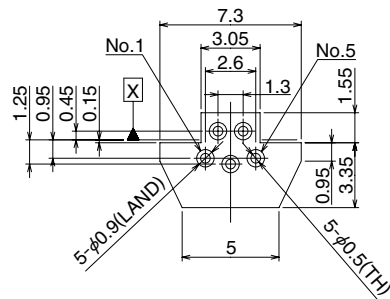

### ● Micro B - Component, Cover-top - Right angle through hole

All dimensions: mm

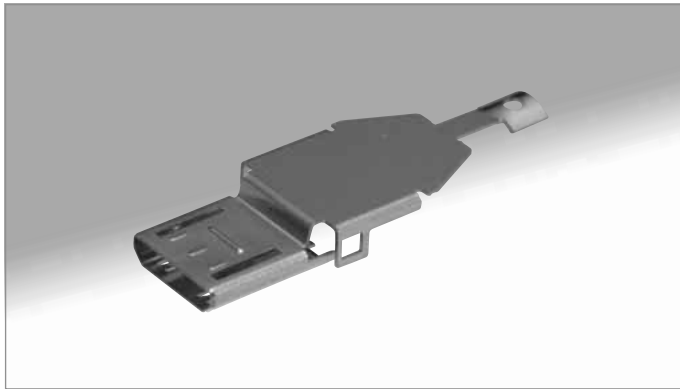

Part Number	CL No.	Packaging
ZX10-B-SLDA	242-0031-2	4,500 pieces per reel

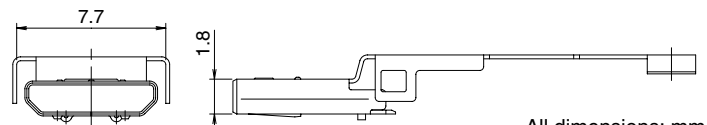
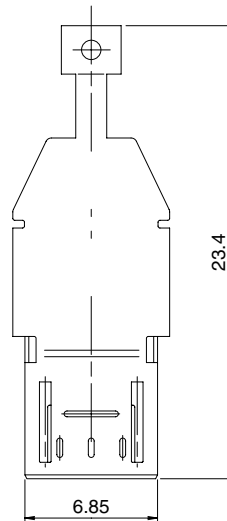

All dimensions: mm

## ■ Plugs

### ● Micro B - Component, Cover-bottom – Right angle through hole

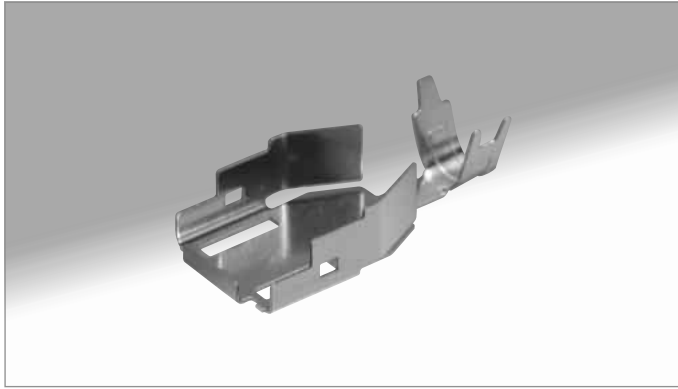

Part Number	CL No.	Packaging
ZX10-SLDB(3.3)	242-0032-5	4,500 pieces per reel

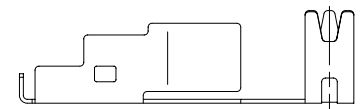
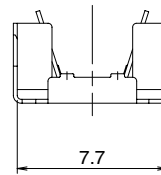
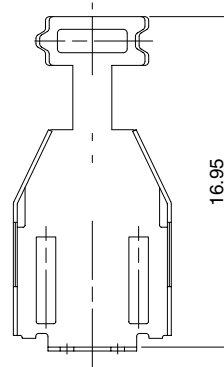

All dimensions: mm

### ● Assembled

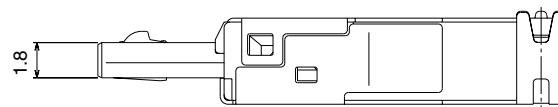
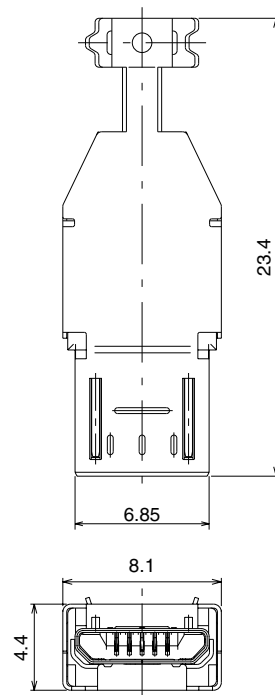

All dimensions: mm

## Plugs

### ● Micro B - Assembly (insulator/contacts/lock) - Straight through hole PCB wire soldering (non-direct)



Part Number	CL No.
ZX20-B-5S-UNIT(12)	242-0012-8-12

Contact HRS for Cable Termination Procedure Manual.

#### PCB mounting pattern

\*PCB required (not supplied)  
 Max. thickness: 0.6mm

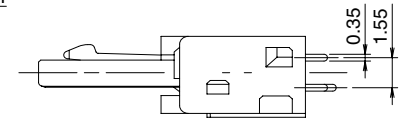
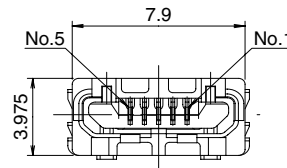
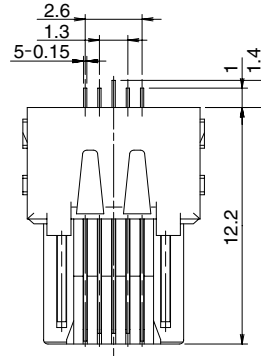
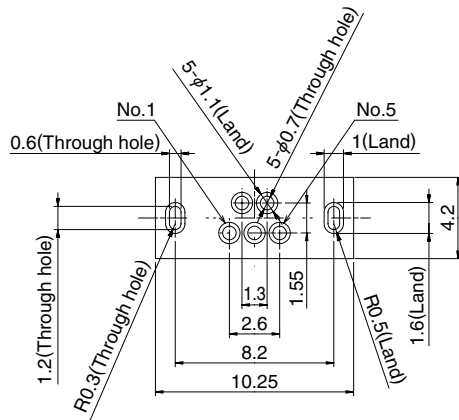

All dimensions: mm

### ● Micro B - Component, Cover - Straight, through hole

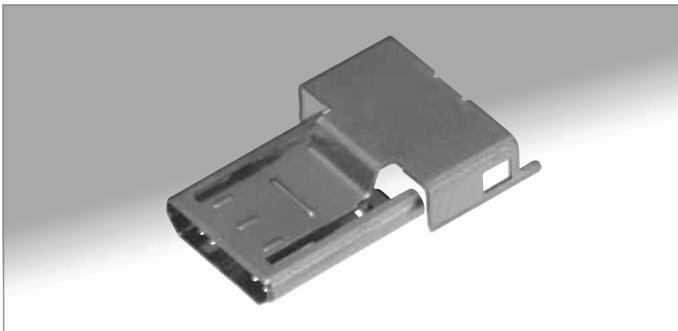

Part Number	CL No.	Packaging
ZX20-B-SLDC	242-0022-1	4,000 pieces per reel

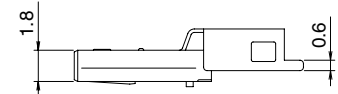
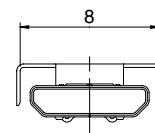
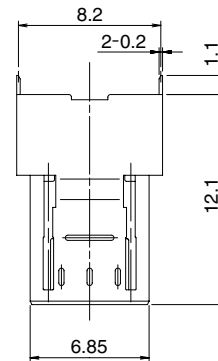

### ● Assembled

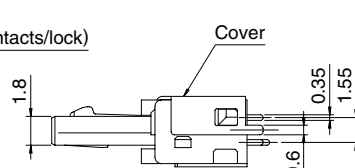
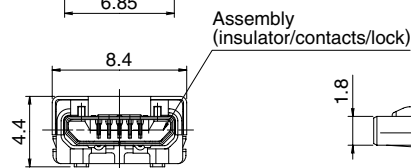
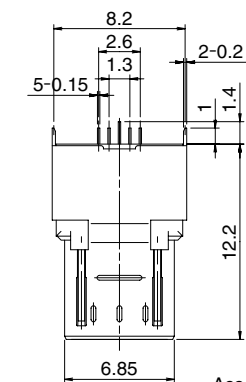

All dimensions: mm

## Plugs

### ● Micro B - Assembly (insulator/contacts/lock) - Right angle SMT



Part Number	CL No.
ZX64-B-5S-UNIT(14)	242-0009-0-14

Contact HRS for Cable Termination Procedure Manual.

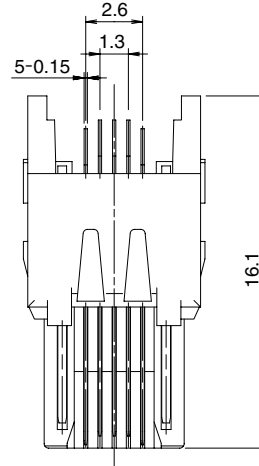

PCB mounting pattern  
 \*PCB required (not supplied)  
 Max. thickness: 1.0mm

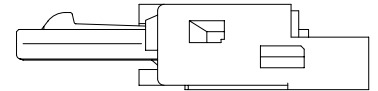
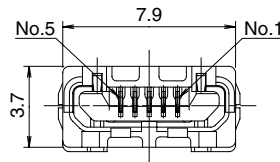
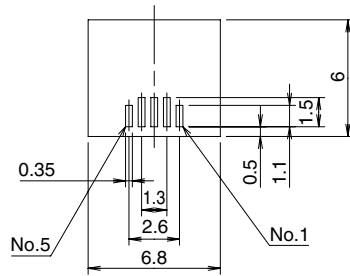

All dimensions: mm

### ● Micro B - Component, Cover-top – Right angle SMT



Part Number	CL No.	Packaging
ZX64-B-SLDA	242-0013-0	4,000 pieces per reel

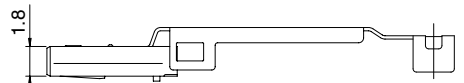
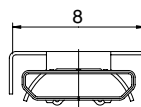
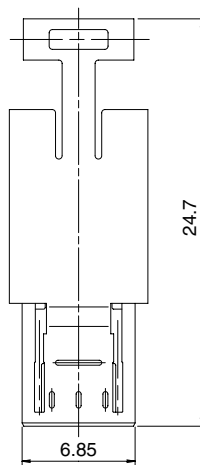

All dimensions: mm

## ■ Plugs

### ● Micro B - Component, Cover-bottom - Right angle SMT

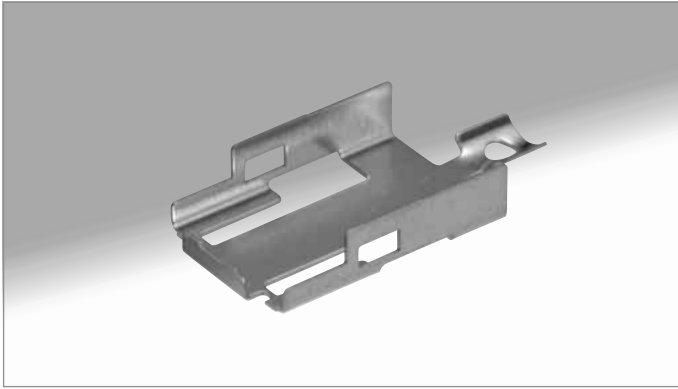

Part Number	CL No.	Packaging
ZX64-SLDB	242-0049-8	4,000 pieces per reel

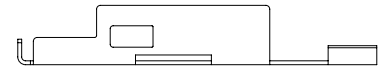
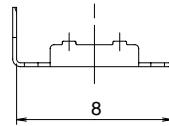
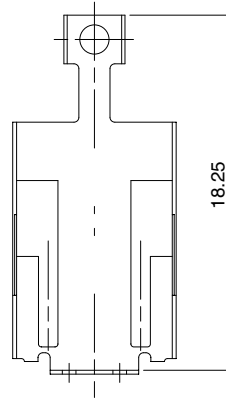

### ● Assembled

All dimensions: mm

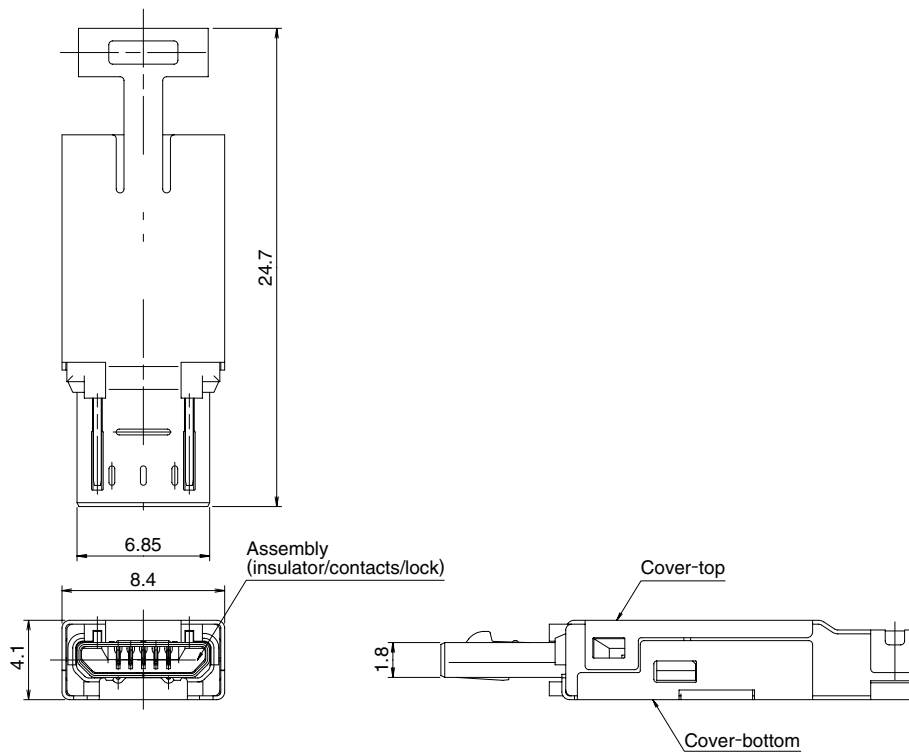

All dimensions: mm

## Plugs

### ● Micro B - Component, Shell/cover – Right angle SMT

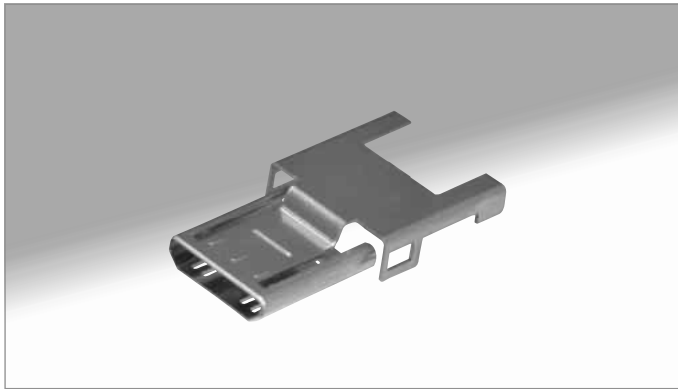

Shell/cover, without cable clamp  
 This shell/cover does not require ZX64-SLDB.

Part Number	CL No.	Packaging
ZX64-B-SLDC	242-0018-4	4,000 pieces per reel

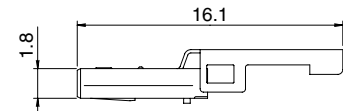
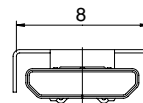
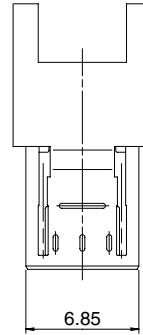

### ● Assembled

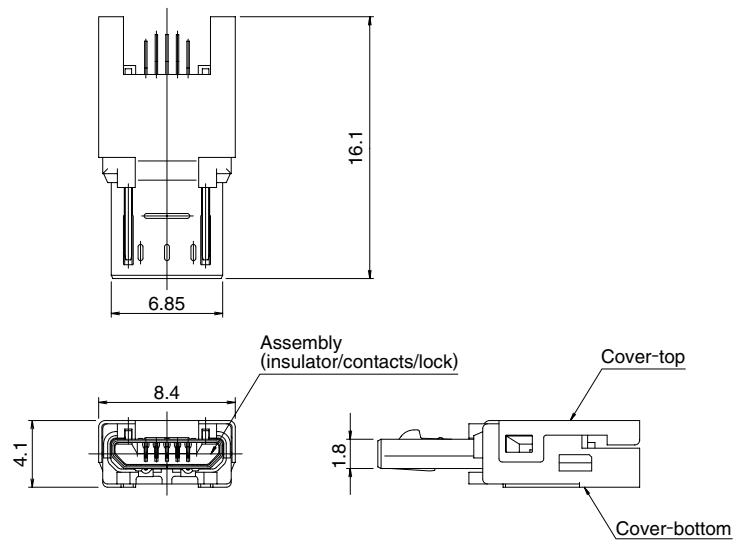

All dimensions: mm



## Plugs

### ● Micro A - Assembly (insulator/contacts/lock) - Direct wire soldering

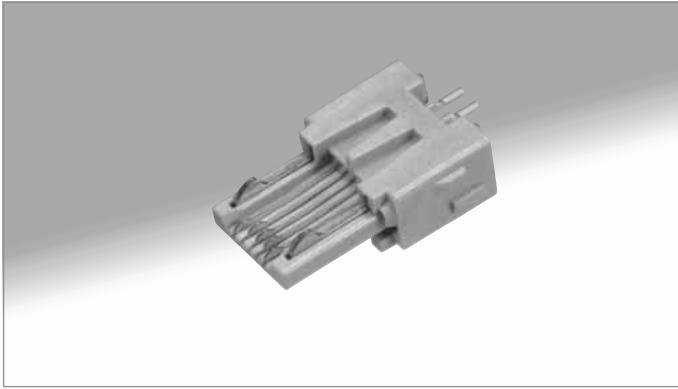

Part Number	CL No.
ZX40-A-5S-UNIT	242-0010-2

Contact HRS for Cable Termination Procedure Manual.

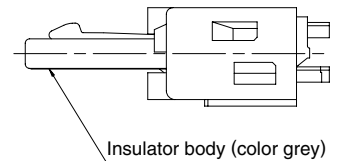
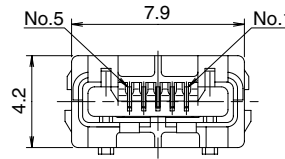
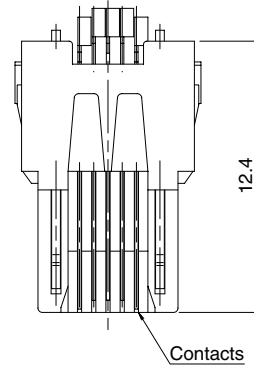
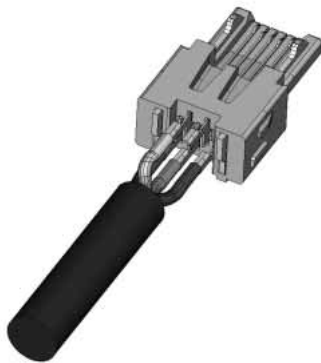

All dimensions: mm

### ● Micro A - Component, Cover-top - Direct wire soldering

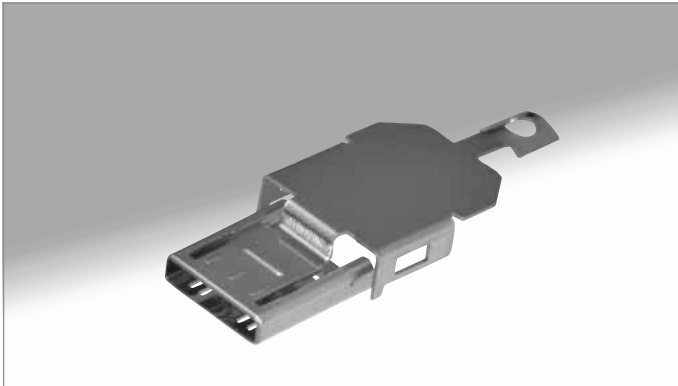

Part Number	CL No.	Packaging
ZX40-A-SLDA	242-0011-5	4,000 pieces per reel

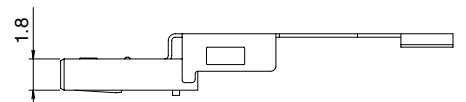
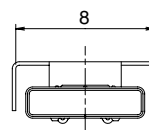
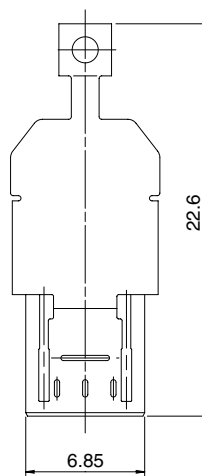

All dimensions: mm

## ■ Plugs

### ● Micro A, Micro B - Component, Cover-bottom - Direct wire soldering

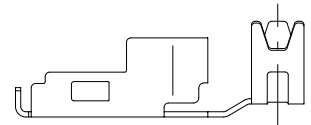
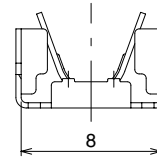
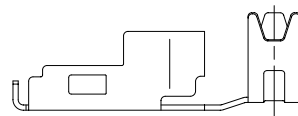
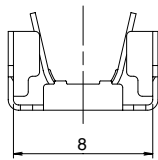
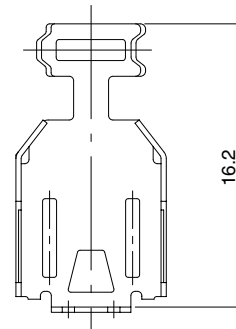
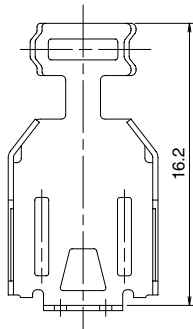
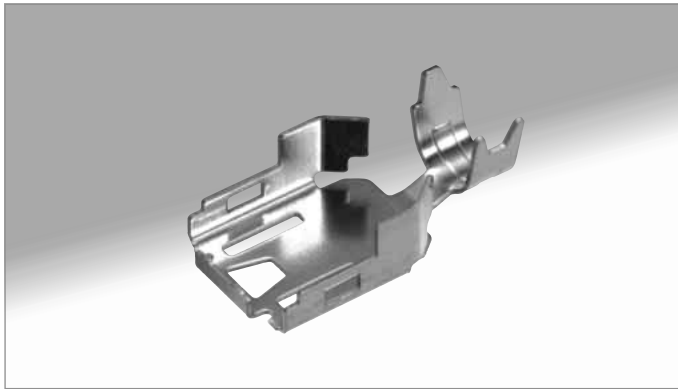

All dimensions: mm

ZX40-SLDB

ZX40-SLDB(3.3)

Part Number	CL No.	Packaging	Cable dia.
ZX40-SLDB	242-0004-0	4,000 pieces per reel	φ3.8
ZX40-SLDB(3.3)	242-0023-4		φ3.3

### ● Assembled

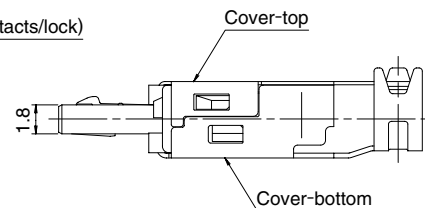
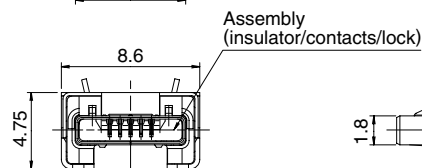
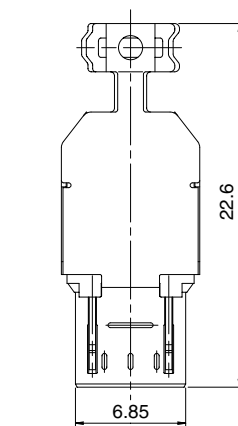

All dimensions: mm

## ■ Plug-Vertical, cradle mount, Shell through hole

### ● Micro B, with lock

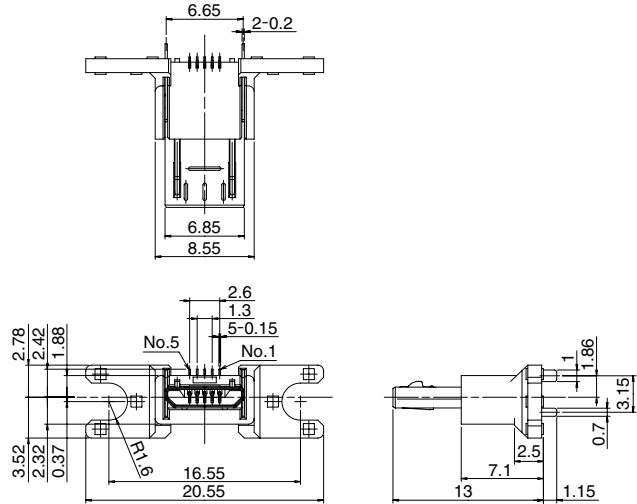
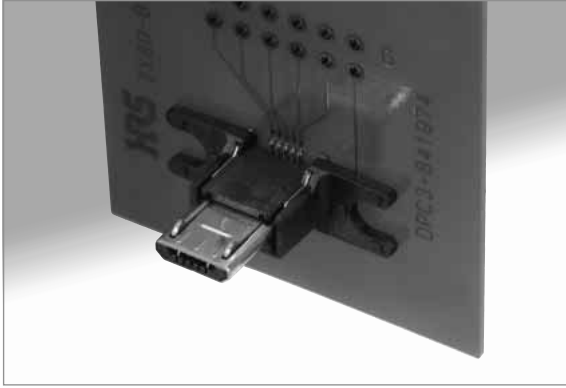

Part Number	CL No.	Packaging
ZX80-B-5S	242-0017-1	100 pieces

All dimensions: mm

### ● Micro B, without lock

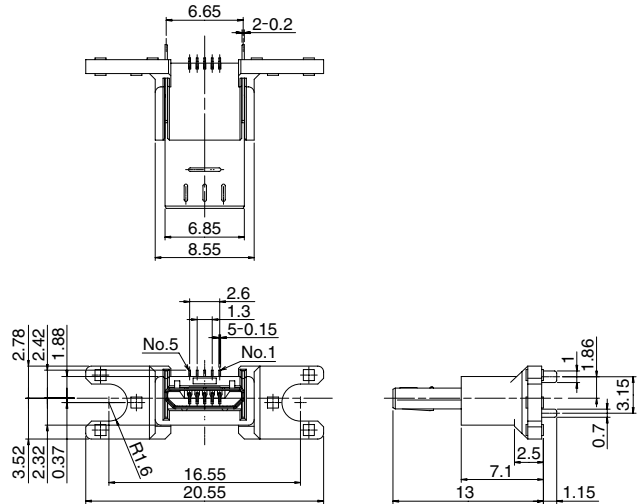
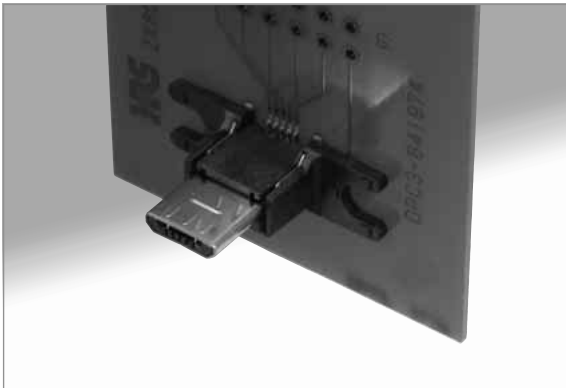

Part Number	CL No.	Packaging
ZX80-B-5SA	242-0019-7	100 pieces

## ■ PCB mounting pattern

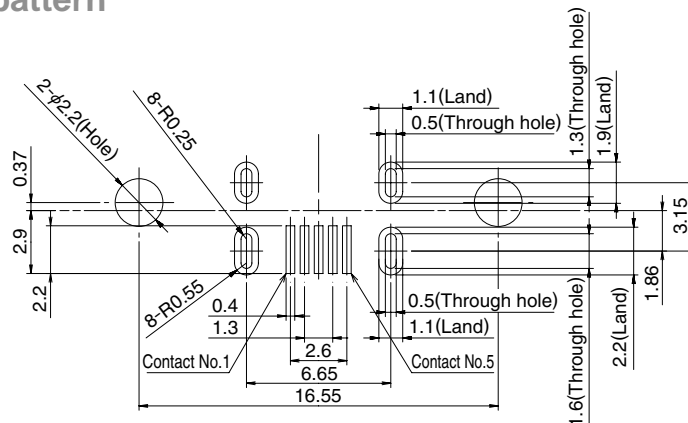

All dimensions: mm

## ■ Packaging Specifications

### ● Embossed carrier tape dimensions

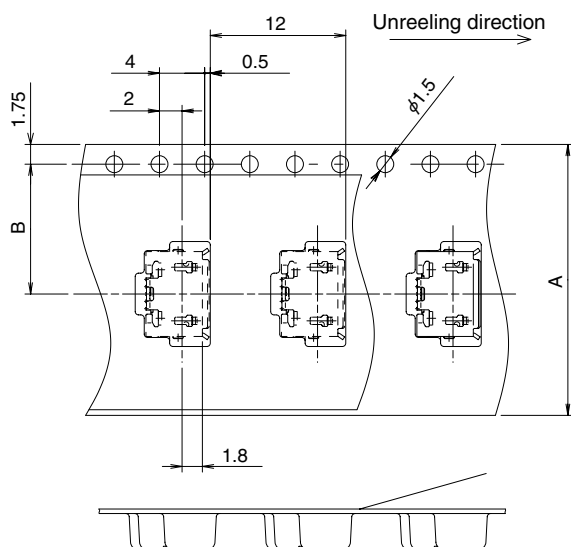

Part Number	A dimension	B dimension
ZX62-B-5PA	24	11.5
ZX62-AB-5PA	24	11.5
ZX62M-B-5P	24	11.5
Other	16	7.5

### ● Reel Dimensions

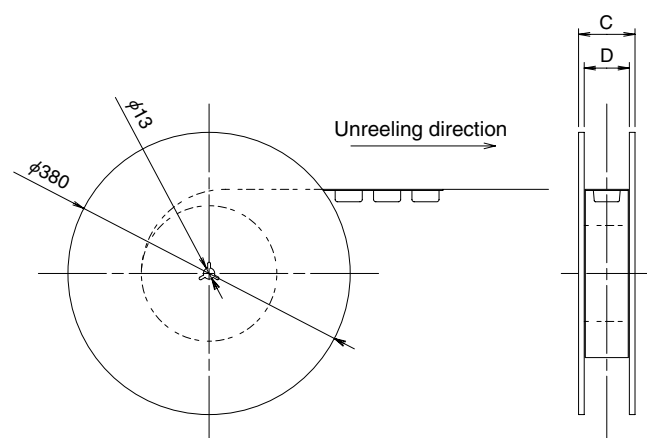

Part Number	C dimension	D dimension
ZX62-B-5PA	30.4	24.4
ZX62-AB-5PA	30.4	24.4
ZX62M-B-5P	30.4	24.4
Other	22.4	16.4

Note : Tape and reel packaging (2,000 pieces/reel).  
 Order by number of reels.

## ■ Recommended Temperature Profile - Receptacles

### ● Using lead-free solder paste

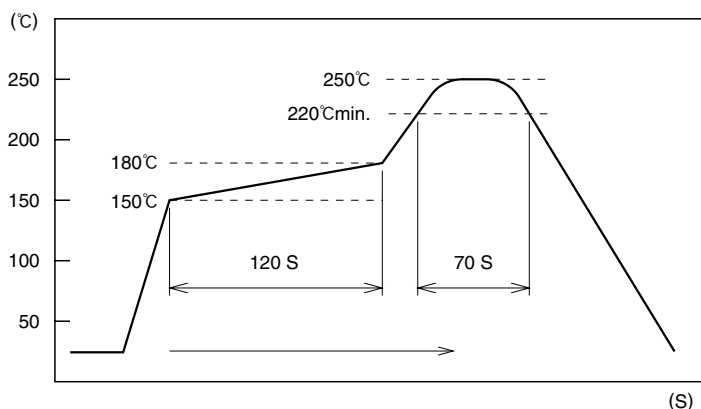

#### HRS test condition

Solder composition : Paste, 96.5%Sn/3.0%Ag/0.5%Cu

Test board : Glass epoxy 35mm×35mm×0.8mm thick

The temperature profile is based on the left conditions. In individual applications the actual temperature may vary, depending on solder paste type, volume/thickness and board size/thickness. Contact your solder paste and equipment manufacturer for specific recommendations.

Note 1: Up to 2 cycles of Reflow soldering are possible under the same conditions, provided that there is a return to normal temperature between the first and second cycle.

Note 2: The temperature profile indicates the board surface temperature at the point of contacts with the connector terminals.

## ■ Precautions

1. Exercise care when handling the connectors. Do not subject them to excessive external forces when mating/un-mating.
2. Mate and un-mate as intended, holding by the overmolded body, in the correct direction. Do not un-mate by pulling on the cable.
3. Some tooling marks may be visible on the surfaces of receptacle (shell/cover). No form/fit or function is affected.
4. Appearance of the surface finishes on the receptacles may vary between production runs. No affect on form, fit or function.



## HIROSE ELECTRIC CO.,LTD.

5-23,OSAKI 5-CHOME,SHINAGAWA-KU,TOKYO 141-8587,JAPAN

PHONE: 81-3-3491-9741, FAX: 81-3-3493-2933

<http://www.hirose.com>

<http://www.hirose-connectors.com>



Компания «ЭлектроПласт» предлагает заключение долгосрочных отношений при поставках импортных электронных компонентов на взаимовыгодных условиях!

Наши преимущества:

- Оперативные поставки широкого спектра электронных компонентов отечественного и импортного производства напрямую от производителей и с крупнейших мировых складов;
- Поставка более 17-ти миллионов наименований электронных компонентов;
- Поставка сложных, дефицитных, либо снятых с производства позиций;
- Оперативные сроки поставки под заказ (от 5 рабочих дней);
- Экспресс доставка в любую точку России;
- Техническая поддержка проекта, помощь в подборе аналогов, поставка прототипов;
- Система менеджмента качества сертифицирована по Международному стандарту ISO 9001;
- Лицензия ФСБ на осуществление работ с использованием сведений, составляющих государственную тайну;
- Поставка специализированных компонентов (Xilinx, Altera, Analog Devices, Intersil, Interpoint, Microsemi, Aeroflex, Peregrine, Syfer, Eurofarad, Texas Instrument, Miteq, Cobham, E2V, MA-COM, Hittite, Mini-Circuits, General Dynamics и др.);

Помимо этого, одним из направлений компании «ЭлектроПласт» является направление «Источники питания». Мы предлагаем Вам помощь Конструкторского отдела:

- Подбор оптимального решения, техническое обоснование при выборе компонента;
- Подбор аналогов;
- Консультации по применению компонента;
- Поставка образцов и прототипов;
- Техническая поддержка проекта;
- Защита от снятия компонента с производства.



#### Как с нами связаться

**Телефон:** 8 (812) 309 58 32 (многоканальный)

**Факс:** 8 (812) 320-02-42

**Электронная почта:** [org@eplast1.ru](mailto:org@eplast1.ru)

**Адрес:** 198099, г. Санкт-Петербург, ул. Калинина, дом 2, корпус 4, литера А.