

EN55022B Compliant 36V, 2A DC/DC μ Module Regulator

FEATURES

- Complete Step-Down Switch Mode Power Supply
- Wide Input Voltage Range: 3.6V to 36V
- 2A Output Current
- 0.8V to 10V Output Voltage
- Selectable Switching Frequency: 200kHz to 2.4MHz
- EN55022 Class B Compliant
- Current Mode Control
- Programmable Soft-Start
- SnPb (BGA) or RoHS Compliant (LGA and BGA) Finish
- Low Profile, Surface Mount LGA (9mm \times 15mm \times 2.82mm) and BGA (9mm \times 15mm \times 3.42mm) Packages

APPLICATIONS

- Automotive Battery Regulation
- Power for Portable Products
- Distributed Supply Regulation
- Industrial Supplies
- Wall Transformer Regulation

DESCRIPTION

The **LTM[®]8032** is an electromagnetic compatible (EMC) 36V, 2A DC/DC step-down μ Module[®] regulator designed to meet the radiated emissions requirements of EN55022. Conducted emission requirements can be met by adding standard filter components. Included in the package are the switching controller, power switches, inductor, filters and all support components. Operating over an input voltage range of 3.6V to 36V, the LTM8032 supports an output voltage range of 0.8V to 10V, and a switching frequency range of 200kHz to 2.4MHz, each set by a single resistor. Only the bulk input and output filter capacitors are needed to finish the design. The low profile package enables utilization of unused space on the bottom of PC boards for high density point of load regulation.

The LTM8032 is packaged in a thermally enhanced, compact and low profile overmolded land grid array (LGA) and ball grid array (BGA) packages suitable for automated assembly by standard surface mount equipment. The LTM8032 is available with SnPb (BGA) or RoHS compliant terminal finish.

LT, LT, LTC, LTM, Linear Technology, the Linear logo, μ Module and Burst Mode are registered trademarks of Linear Technology Corporation. All other trademarks are the property of their respective owners.

TYPICAL APPLICATION

Ultralow Noise 5V/2A DC/DC μ Module Regulator

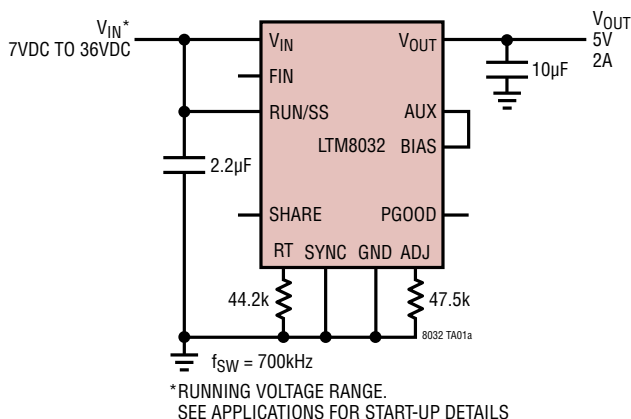

LTM8032 EMI Performance

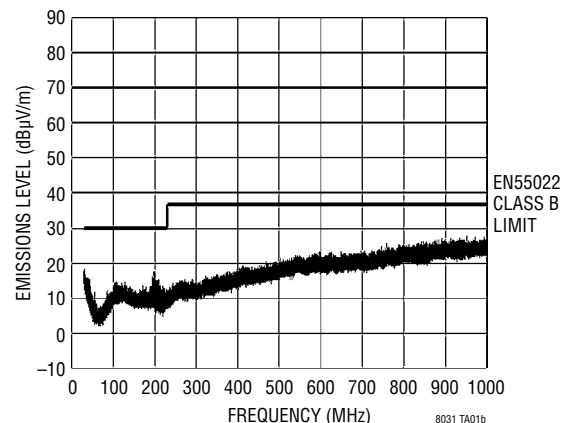

LTM8032

ABSOLUTE MAXIMUM RATINGS

(Note 1)

V_{IN} , FIN, RUN/SS Voltage	40V
ADJ, RT, SHARE Voltage.....	5V
V_{OUT} , AUX	10V
Current from AUX	100mA

PGOOD, SYNC.....	30V
BIAS.....	25V
V_{IN} + BIAS.....	56V
Maximum Junction Temperature (Note 2)	125°C
Solder Temperature.....	245°C

PIN CONFIGURATION

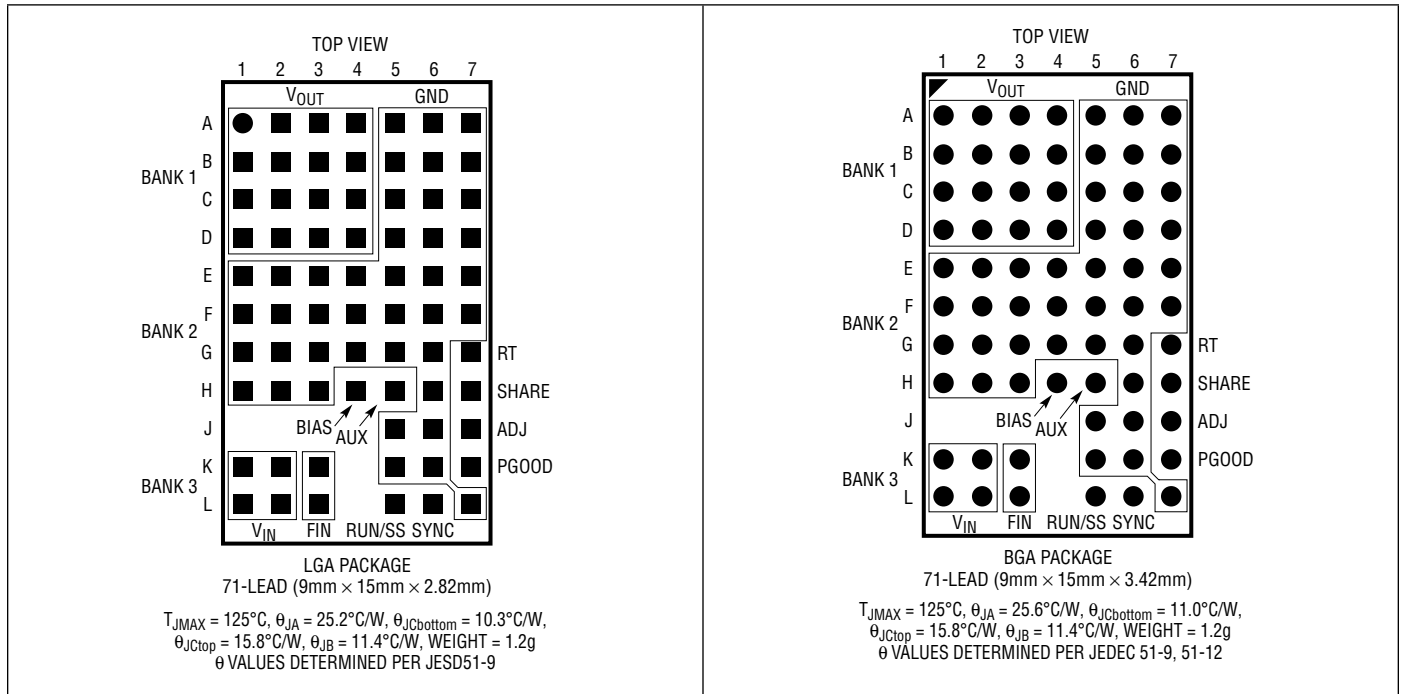

ORDER INFORMATION

PART NUMBER	PAD OR BALL FINISH	PART MARKING*		PACKAGE TYPE	MSL RATING	TEMPERATURE RANGE (Note 2)
		DEVICE	CODE			
LTM8032EV#PBF	Au (RoHS)	LTM8032V	e4	LGA	3	-40°C to 125°C
LTM8032IV#PBF	Au (RoHS)	LTM8032V	e4	LGA	3	-40°C to 125°C
LTM8032MPV#PBF	Au (RoHS)	LTM8032MPV	e4	LGA	3	-55°C to 125°C
LTM8032EY#PBF	SAC305 (RoHS)	LTM8032Y	e1	BGA	3	-40°C to 125°C
LTM8032IY#PBF	SAC305 (RoHS)	LTM8032Y	e1	BGA	3	-40°C to 125°C
LTM8032MPY#PBF	SAC305 (RoHS)	LTM8032Y	e1	BGA	3	-55°C to 125°C
LTM8032MPY	SnPb (63/37)	LTM8032Y	e0	BGA	3	-55°C to 125°C

Consult Marketing for parts specified with wider operating temperature ranges. *Device temperature grade is indicated by a label on the shipping container. Pad or ball finish code is per IPC/JEDEC J-STD-609.

- Pb-free and Non-Pb-free Part Markings:
www.linear.com/leadfree

- Recommended LGA and BGA PCB Assembly and Manufacturing Procedures:

www.linear.com/module/pcbassembly

- LGA and BGA Package and Tray Drawings:
www.linear.com/packaging

ELECTRICAL CHARACTERISTICS

The ● denotes the specifications which apply over the full internal operating temperature range, otherwise specifications are at $T_A = 25^\circ\text{C}$. $V_{IN} = 10\text{V}$, $V_{RUN/SS} = 10\text{V}$, $V_{BIAS} = 3\text{V}$, unless otherwise specified.

SYMBOL	PARAMETER	CONDITIONS	MIN	TYP	MAX	UNITS
V_{IN}	Input DC Voltage		● 3.6		36	V
V_{OUT}	Output DC Voltage	$0.2\text{A} < I_{OUT} \leq 2\text{A}$, R_{ADJ} Open $0.2\text{A} < I_{OUT} \leq 2\text{A}$, $R_{ADJ} = 21.6\text{k}$		0.8 10		V V
I_{OUT}	Continuous Output DC Current	$V_{IN} = 24\text{V}$			2	A
$I_{Q(VIN)}$	V_{IN} Quiescent Current	$V_{RUN/SS} = 0.2\text{V}$ $V_{BIAS} = 3\text{V}$, Not Switching $V_{BIAS} = 0\text{V}$, Not Switching	●	0.6 25 88	60 120	μA μA μA
$I_{Q(BIAS)}$	BIAS Quiescent Current	$V_{RUN/SS} = 0.2\text{V}$ $V_{BIAS} = 3\text{V}$, Not Switching $V_{BIAS} = 0\text{V}$, Not Switching	●	0.03 60 1	120 5	μA μA μA
$\frac{\Delta V_{OUT}}{V_{OUT}}$	Line Regulation	$10\text{V} \leq V_{IN} \leq 36\text{V}$, $I_{OUT} = 1\text{A}$, $V_{OUT} = 3.3\text{V}$		0.1		%
	Load Regulation	$V_{IN} = 24\text{V}$, $0.2\text{A} \leq I_{OUT} \leq 2\text{A}$, $V_{OUT} = 3.3\text{V}$		0.3		%
$V_{OUT(AC_RMS)}$	Output Ripple (RMS)	$V_{IN} = 24\text{V}$, $I_{OUT} = 2\text{A}$, $V_{OUT} = 3.3\text{V}$		6		mV
f_{SW}	Switching Frequency	$R_T = 113\text{k}$		325		kHz
V_{ADJ}	Voltage at ADJ Pin		● 765	790	815	mV
$V_{BIAS(MIN)}$	Minimum BIAS Voltage for Proper Operation			1.9	2.8	V
I_{ADJ}	Current Out of ADJ Pin	$V_{RUN/SS} = 0\text{V}$, $V_{ADJ} = 0\text{V}$, $V_{OUT} = 1\text{V}$		4		μA
$I_{RUN/SS}$	RUN/SS Pin Current	$V_{RUN/SS} = 2.5\text{V}$		5	10	μA
$V_{IH(RUN/SS)}$	RUN/SS Input High Voltage		2.5			V
$V_{IL(RUN/SS)}$	RUN/SS Input Low Voltage				0.2	V
$V_{PG(TH)}$	ADJ Voltage Threshold for PGOOD to Switch			730		mV
I_{PGO}	PGOOD Leakage	$V_{PG} = 30\text{V}$		0.1	1	μA
I_{PGSINK}	PGOOD Sink Current	$V_{PG} = 0.4\text{V}$	200	800		μA
V_{SYNCIL}	SYNC Input Low Threshold	$f_{SYNC} = 550\text{kHz}$			0.5	V
V_{SYNCIH}	SYNC Input High Threshold	$f_{SYNC} = 550\text{kHz}$	0.7			V
$I_{SYNC(BIAS)}$	SYNC Pin Bias Current	$V_{SYNC} = 0\text{V}$, $V_{BIAS} = 0\text{V}$		0.1		μA
$V_{IN(RIPPLE)}$	550kHz Narrowband Conducted Emission 1MHz Narrowband Conducted Emission 3MHz Narrowband Conducted Emission	$V_{IN} = 24\text{V}$, $V_{OUT} = 3.3\text{V}$, $I_{OUT} = 2\text{A}$, $f_{SW} = 550\text{kHz}$, 5 μH LISN		89 69 51		dB μV dB μV dB μV

Note 1: Stresses beyond those listed under Absolute Maximum Ratings may cause permanent damage to the device. Exposure to any Absolute Maximum Rating condition for extended periods may affect device reliability and lifetime.

Note 2: The LTM8032E is guaranteed to meet performance specifications from 0°C to 125°C internal. Specifications over the -40°C to 125°C internal temperature range are assured by design, characterization and

correlation with statistical process controls. LTM8032I is guaranteed to meet specifications over the full -40°C to 125°C internal operating temperature range. The LTM8032MP is guaranteed to meet specifications over the full -55°C to 125°C internal operating temperature range. Note that the maximum internal temperature is determined by specific operating conditions in conjunction with board layout, the rated package thermal resistance and other environmental factors.

TYPICAL PERFORMANCE CHARACTERISTICS $T_A = 25^\circ\text{C}$, unless otherwise noted.

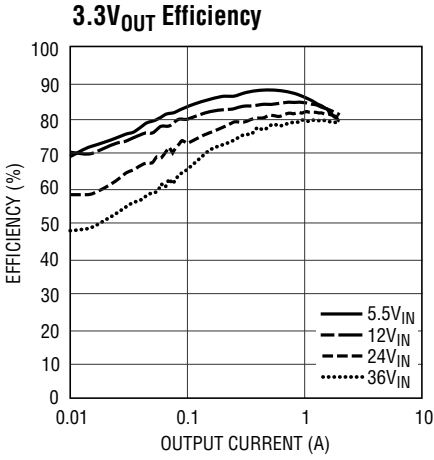

8031 G01

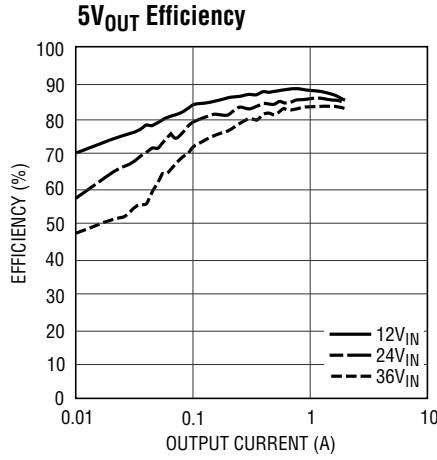

8031 G02

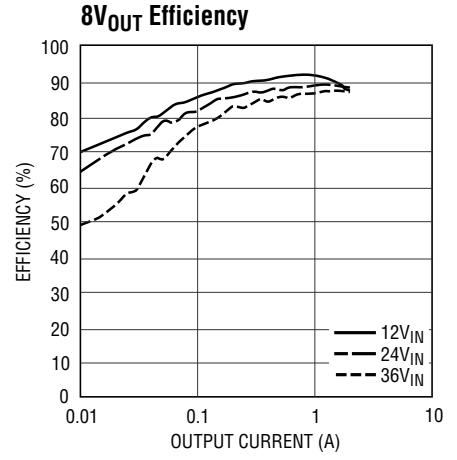

8031 G03

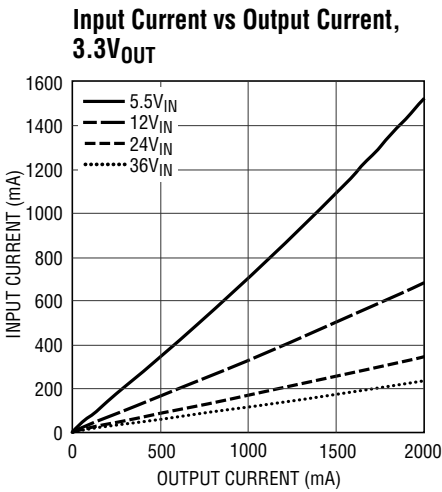

8032 G04

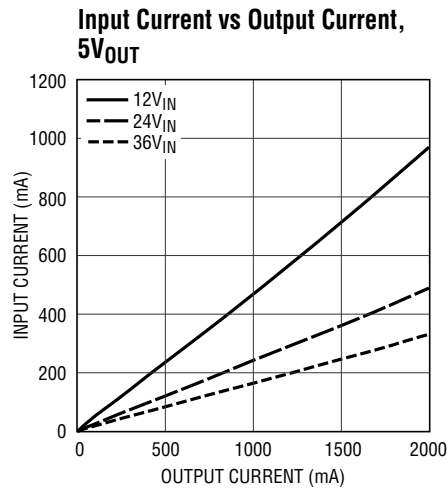

8032 G05

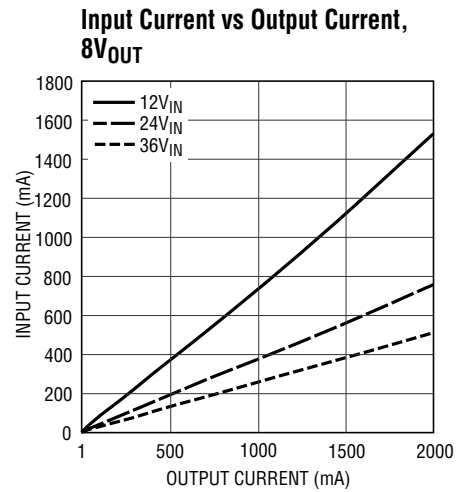

8032 G06

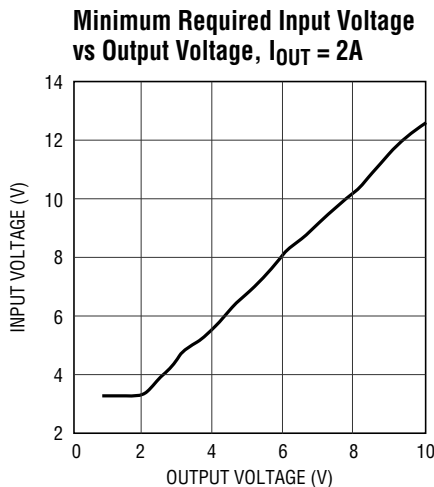

8032 G07

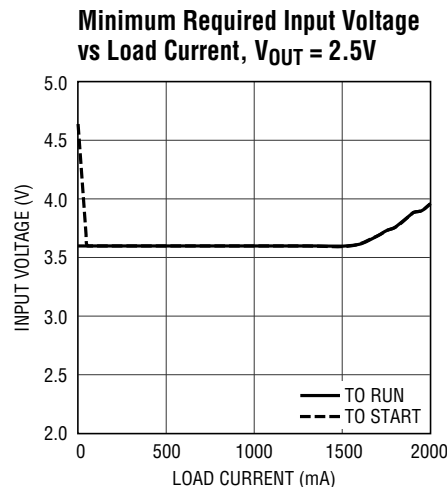

8032 G08

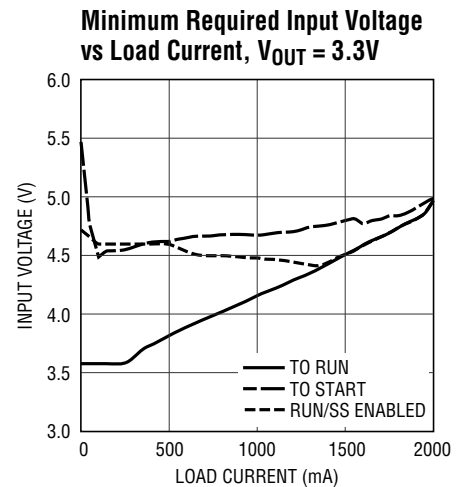

8032 G09

TYPICAL PERFORMANCE CHARACTERISTICS $T_A = 25^\circ\text{C}$, unless otherwise noted.

Minimum Required Input Voltage vs Load Current, $V_{OUT} = 5\text{V}$

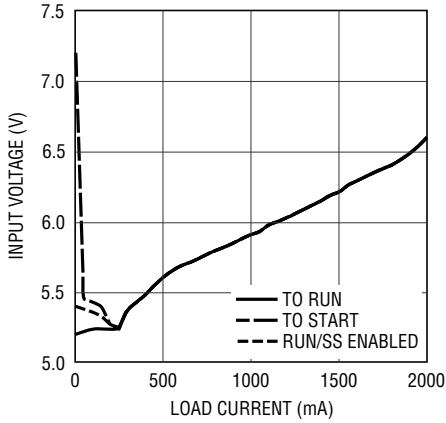

8032 G10

Minimum Required Input Voltage vs Load Current, $V_{OUT} = 8\text{V}$

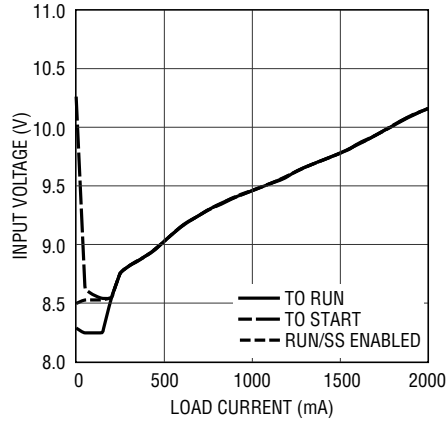

8032 G11

Bias Current vs Output Current

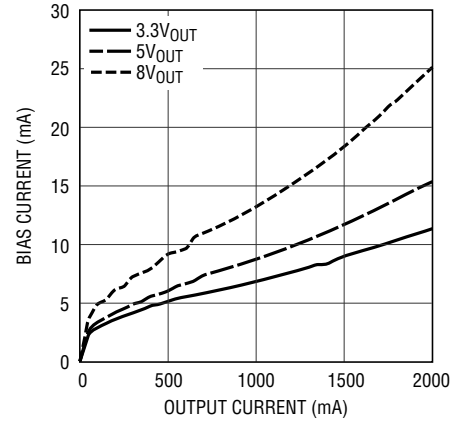

8032 G12

Output Current vs Input Voltage (Output Shorted)

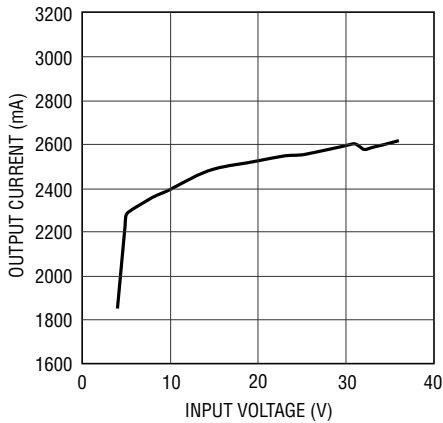

8032 G13

Input Current vs Input Voltage (Output Shorted)

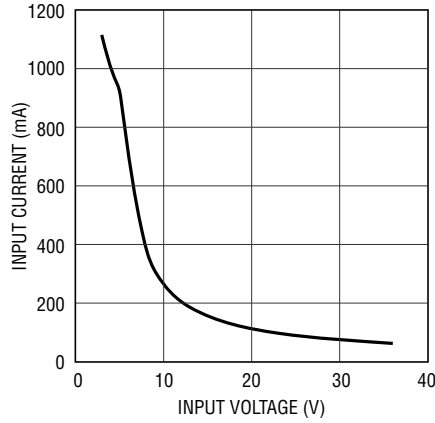

8032 G14

Temperature Rise vs Load Current, $V_{OUT} = 2.5\text{V}$ (LGA)

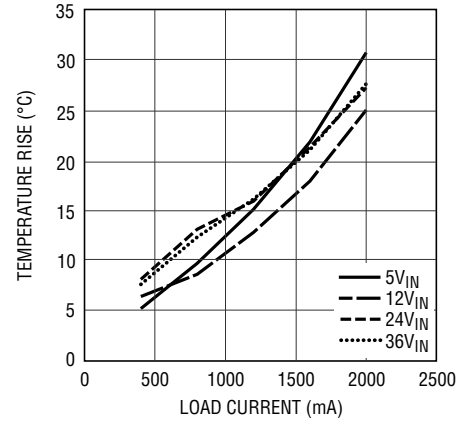

8032 G15

Temperature Rise vs Load Current, $V_{OUT} = 3.3\text{V}$ (LGA)

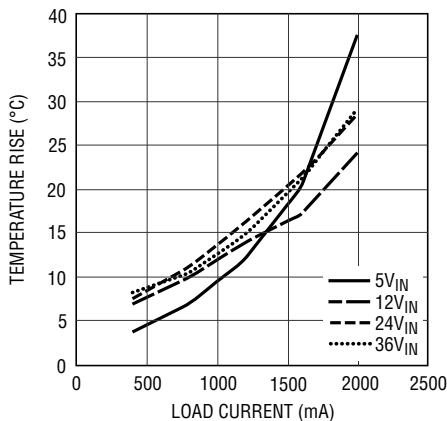

8032 G16

Temperature Rise vs Load Current, $V_{OUT} = 5\text{V}$ (LGA)

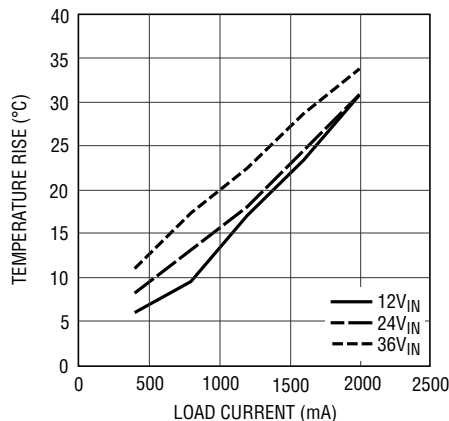

8032 G17

Temperature Rise vs Load Current, $V_{OUT} = 8\text{V}$ (LGA)

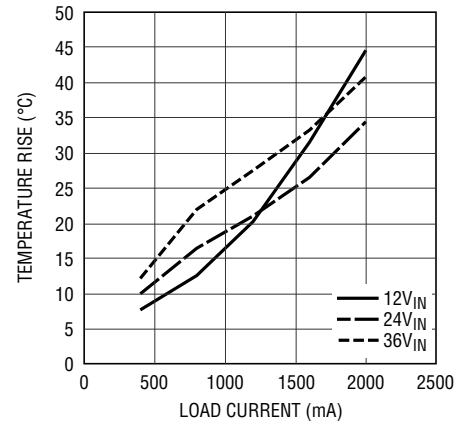

8032 G18

TYPICAL PERFORMANCE CHARACTERISTICS $T_A = 25^\circ\text{C}$, unless otherwise noted.

Temperature Rise vs Load Current, $V_{OUT} = 10\text{V}$ (LGA)

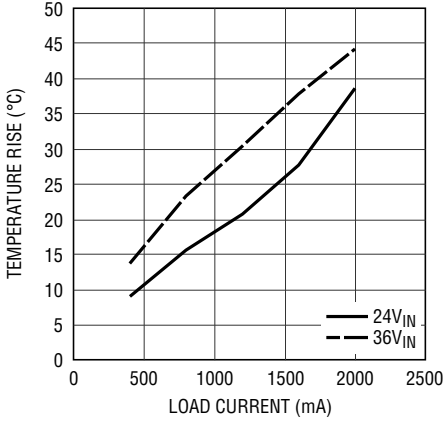

8032 G19

Radiated Emissions

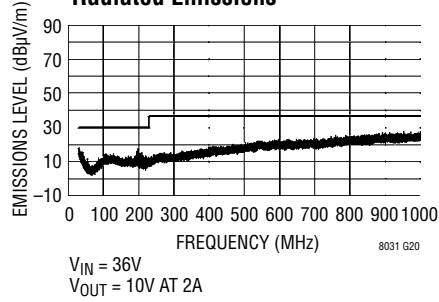

8031 G20

Radiated Emissions

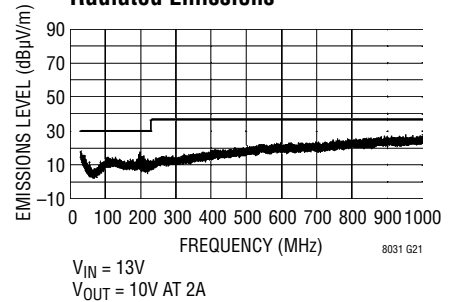

8031 G21

Temperature Rise vs Load Current, $V_{OUT} = 2.5\text{V}$ (BGA)

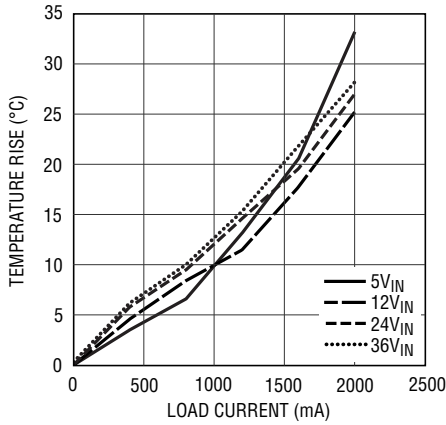

8032 G22

Temperature Rise vs Load Current, $V_{OUT} = 3.3\text{V}$ (BGA)

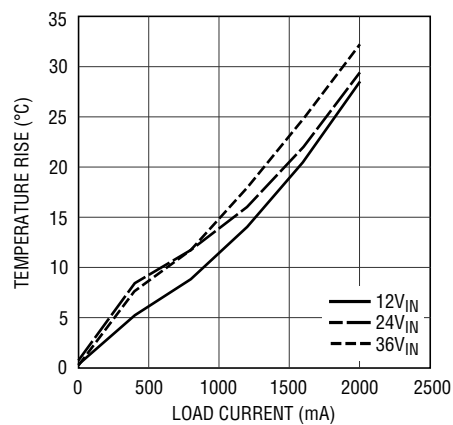

8032 G23

Temperature Rise vs Load Current, $V_{OUT} = 5\text{V}$ (BGA)

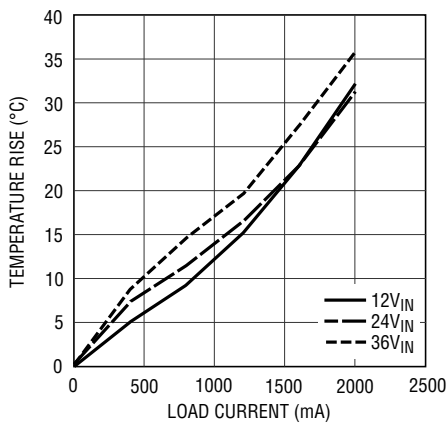

8032 G24

Temperature Rise vs Load Current, $V_{OUT} = 10\text{V}$ (BGA)

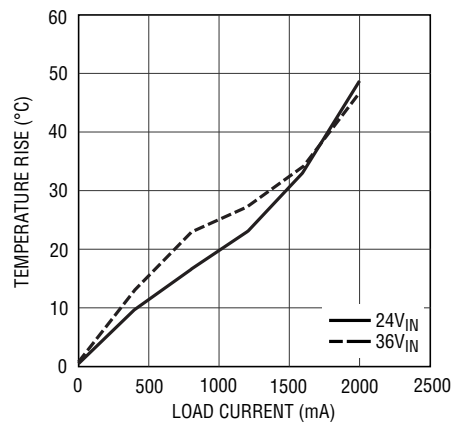

8032 G25

PIN FUNCTIONS

V_{IN} (Bank 3): The V_{IN} pin supplies current to the LTM8032's internal regulator and to the internal power switch. This pin must be locally bypassed with an external, low ESR capacitor of at least 2.2μF.

FIN (K3, L3): Filtered Input. This is the node after the input EMI filter. Use this only if there is a need to modify the behavior of the integrated EMI filter or if V_{IN} rises or falls rapidly; otherwise, leave these pins unconnected. See the Applications Information section for more details.

GND (Bank 2): Tie these GND pins to a local ground plane below the LTM8032 and the circuit components. In most applications, the bulk of the heat flow out of the LTM8032 is through these pads, so the printed circuit design has a large impact on the thermal performance of the part. See the PCB Layout and Thermal Considerations sections for more details. Return the feedback divider (R_{ADJ}) to this net.

V_{OUT} (Bank 1): Power Output Pins. Apply the output filter capacitor and the output load between these pins and GND pins.

AUX (Pin H5): Low Current Voltage Source for BIAS. The AUX pin is internally connected to V_{OUT} and is placed adjacent to the BIAS pin to ease printed circuit board routing. Although this pin is internally connected to V_{OUT}, **do not** connect this pin to the load. If this pin is not tied to BIAS, leave it floating.

BIAS (Pin H4): The BIAS pin connects to the internal power bus. Connect to a power source greater than 2.8V. If the output is greater than 2.8V, connect this pin to AUX. If the output voltage is less, connect this to a voltage source between 2.8V and 25V. Also, make sure that BIAS + V_{IN} is less than 56V.

RUN/SS (Pin L5): Pull RUN/SS pin to less than 0.2V to shut down the LTM8032. Tie to 2.5V or more for normal operation. If the shutdown feature is not used, tie this pin to the V_{IN} pin. RUN/SS also provides a soft-start function; see the Applications Information section.

RT (Pin G7): The RT pin is used to program the switching frequency of the LTM8032 by connecting a resistor from this pin to ground. The Applications Information section of the data sheet includes a table to determine the resistance value based on the desired switching frequency. Minimize capacitance at this pin.

SHARE (Pin H7): Tie this to the SHARE pin of another LTM8032 when paralleling the outputs. Otherwise, do not connect (leave floating).

SYNC (Pin L6): This is the external clock synchronization input. Ground this pin for low ripple Burst Mode[®] operation at low output loads. Tie to a stable voltage source greater than 0.7V to disable Burst Mode operation. Do not leave this pin floating. Tie to a clock source for synchronization. Clock edges should have rise and fall times faster than 1μs. See synchronization section in Applications Information.

PGOOD (Pin K7): The PGOOD pin is the open-collector output of an internal comparator. PGOOD remains low until the ADJ pin is within 10% of the final regulation voltage. The PGOOD output is valid when V_{IN} is above 3.6V and RUN/SS is high. If this function is not used, leave this pin floating.

ADJ (Pin J7): The LTM8032 regulates its ADJ pin to 0.79V. Connect the adjust resistor from this pin to ground. The value of R_{ADJ} is given by the equation:

$$R_{ADJ} = \frac{196.71}{V_{OUT} - 0.79}$$

where R_{ADJ} is in kΩ.

BLOCK DIAGRAM

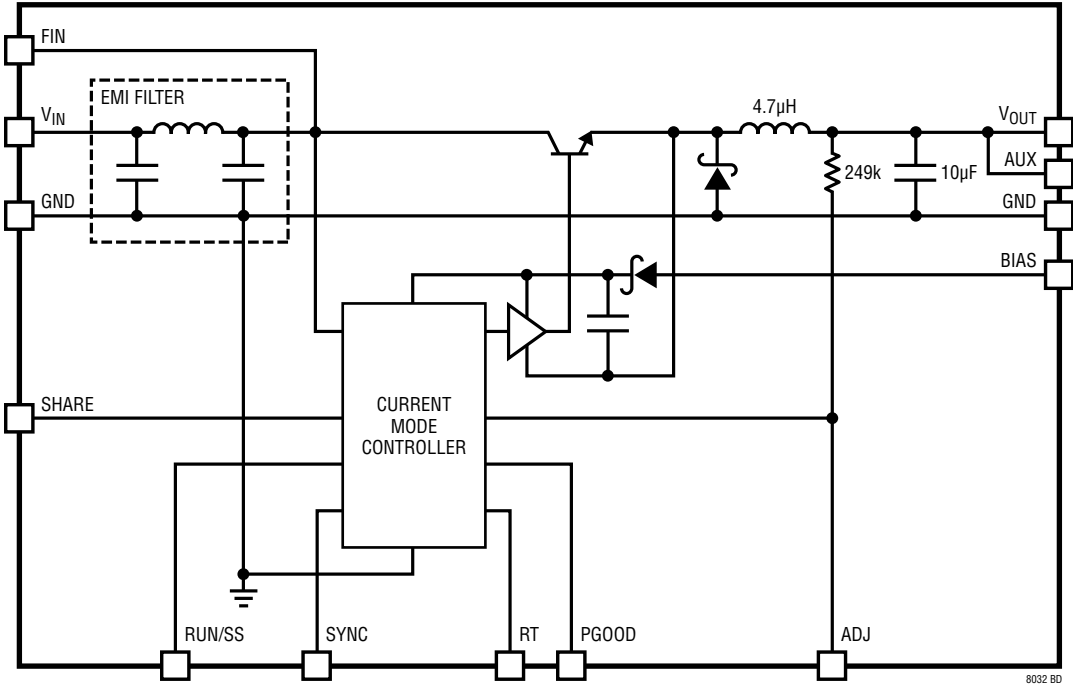

OPERATION

The LTM8032 is a standalone nonisolated step-down switching DC/DC power supply. It can deliver up to 2A of DC output current with only bulk external input and output capacitors. This module provides a precisely regulated output voltage programmable via one external resistor from 0.8VDC to 10VDC. The input voltage range is 3.6V to 36V. Given that the LTM8032 is a step-down converter, make sure that the input voltage is high enough to support the desired output voltage and load current. A simplified Block Diagram is given on the previous page.

The LTM8032 is designed with an input EMI filter and other features to make its radiated emissions compliant with several EMC specifications including EN55022 class B. Compliance with conducted emissions requirements may be obtained by adding a standard input filter.

The LTM8032 contains a current mode controller, power switching element, power inductor, power Schottky diode and a modest amount of input and output capacitance. The LTM8032 is a fixed frequency PWM regulator. The switching frequency is set by simply connecting the appropriate resistor value from the RT pin to GND.

An internal regulator provides power to the control circuitry. The bias regulator can draw power from the V_{IN} pin, but if the BIAS pin is connected to an external voltage higher than 2.8V, bias power will be drawn from the external source (typically the regulated output voltage). This improves efficiency. The RUN/SS pin is used to place the LTM8032 in shutdown, disconnecting the output and reducing the input current to less than 1 μ A.

To further optimize efficiency, the LTM8032 automatically switches to Burst Mode operation in light load situations. Between bursts, all circuitry associated with controlling the output switch is shut down reducing the input supply current to 50 μ A in a typical application. The oscillator reduces the LTM8032's operating frequency when the voltage at the ADJ pin is low. This frequency foldback helps to control the output current during start-up and overload.

The LTM8032 contains a power good comparator which trips when the ADJ pin is at 90% of its regulated value. The PGOOD output is an open-collector transistor that is off when the output is in regulation, allowing an external resistor to pull the PGOOD pin high. Power good is valid when the LTM8032 is enabled and V_{IN} is above 3.6V.

APPLICATIONS INFORMATION

For most applications, the design process is straight forward, summarized as follows:

1. Look at Table 1 and find the row that has the desired input range and output voltage.
2. Apply the recommended C_{IN} , C_{OUT} , R_{ADJ} and R_T values.
3. Connect BIAS as indicated.

As the integrated input EMI filter may ring in response to an application of a step input voltage, a bulk capacitance, series resistance or some clamping mechanism may be required. See the Hot-Plugging Safely section for details.

While these component combinations have been tested for proper operation, it is incumbent upon the user to verify proper operation over the intended system's line, load and environmental conditions.

Capacitor Selection Considerations

The C_{IN} and C_{OUT} capacitor values in Table 1 are the minimum recommended values for the associated operating conditions. Applying capacitor values below those indicated in Table 1 is not recommended, and may result in undesirable operation. Using larger values is generally acceptable, and can yield improved dynamic response, if it is necessary. Again, it is incumbent upon the user to verify proper operation over the intended system's line, load and environmental conditions.

Ceramic capacitors are small, robust and have very low ESR. However, not all ceramic capacitors are suitable. X5R and X7R types are stable over temperature and applied voltage and give dependable service. Other types, including Y5V and Z5U have very large temperature and voltage coefficients of capacitance. In an application

APPLICATIONS INFORMATION

Table 1. Recommended Component Values and Configuration

V _{IN}	V _{OUT}	C _{IN}	C _{OUT}	R _{ADJ}	BIAS	f _{OPTIMAL}	R _{T(OPTIMAL)}	f _{MAX}	R _{T(MIN)}
3.6V to 36V	0.82V	2.2μF	200μF 1206	5.62M	≥2.8V, <25V	250k	150k	250k	150k
3.6V to 36V	1.00V	2.2μF	200μF 1206	953k	≥2.8V, <25V	300k	124k	300k	124k
3.6V to 36V	1.20V	2.2μF	147μF 1206	487k	≥2.8V, <25V	350k	105k	350k	105k
3.6V to 36V	1.50V	2.2μF	147μF 1206	280k	≥2.8V, <25V	400k	88.7k	400k	88.7k
3.6V to 36V	1.80V	2.2μF	100μF 1206	196k	≥2.8V, <25V	450k	78.7k	450k	78.7k
3.6V to 36V	2.00V	2.2μF	68μF 1206	165k	≥2.8V, <25V	450k	78.7k	450k	78.7k
4.0V to 36V	2.20V	2.2μF	68μF 1206	140k	≥2.8V, <25V	500k	69.8k	500k	69.8k
4.3V to 36V	2.50V	2.2μF	47μF 1206	115k	≥2.8V, <25V	550k	61.9k	600k	54.9k
5.5V to 36V	3.30V	2.2μF	22μF 1206	78.7k	AUX	600k	54.9k	700k	44.2k
7V to 36V	5.00V	2.2μF	10μF 1206	47.5k	AUX	700k	44.2k	1M	29.4k
10.5V to 36V	8.00V	2.2μF	10μF 1206	27.4k	AUX	800k	39.2k	1.5M	16.2k
3.6V to 15V	0.82V	2.2μF	200μF 1206	5.62M	V _{IN}	250k	150k	600k	54.9k
3.6V to 15V	1.00V	2.2μF	200μF 1206	953k	V _{IN}	300k	124k	700k	44.2k
3.6V to 15V	1.20V	2.2μF	147μF 1206	487k	V _{IN}	350k	105k	800k	39.2k
3.6V to 15V	1.50V	2.2μF	147μF 1206	280k	V _{IN}	400k	88.7k	900k	34.0k
3.6V to 15V	1.80V	2.2μF	100μF 1206	196k	V _{IN}	450k	78.7k	1M	29.4k
3.6V to 15V	2.00V	2.2μF	68μF 1206	165k	V _{IN}	450k	78.7k	1.1M	26.1k
4.0V to 15V	2.20V	2.2μF	68μF 1206	140k	V _{IN}	500k	69.8k	1.25M	22.1k
4.3V to 15V	2.50V	2.2μF	47μF 1206	115k	V _{IN}	550k	61.9k	1.3M	21.0k
5.5V to 15V	3.30V	2.2μF	22μF 1206	78.7k	AUX	600k	54.9k	1.7M	14.0k
7V to 15V	5.00V	2.2μF	10μF 1206	47.5k	AUX	700k	44.2k	2M	10.0k
9V to 24V	0.82V	2.2μF	200μF 1206	5.62M	≥2.8V, <25V	250k	150k	400k	88.7k
9V to 24V	1.00V	2.2μF	200μF 1206	953k	≥2.8V, <25V	300k	124k	450k	79.0k
9V to 24V	1.20V	2.2μF	147μF 1206	487k	≥2.8V, <25V	350k	105k	500k	69.8k
9V to 24V	1.50V	2.2μF	147μF 1206	280k	≥2.8V, <25V	400k	88.7k	550k	61.9k
9V to 24V	1.80V	2.2μF	100μF 1206	196k	≥2.8V, <25V	450k	78.7k	650k	49.9k
9V to 24V	2.00V	2.2μF	68μF 1206	165k	≥2.8V, <25V	450k	78.7k	700k	44.2k
9V to 24V	2.20V	2.2μF	47μF 1206	140k	≥2.8V, <25V	500k	69.8k	750k	42.2k
9V to 24V	2.50V	2.2μF	22μF 1206	115k	≥2.8V, <25V	550k	61.9k	800k	39.2k
9V to 24V	3.30V	2.2μF	22μF 1206	78.7k	AUX	600k	54.9k	1M	29.4k
9V to 24V	5.00V	2.2μF	10μF 1206	47.5k	AUX	700k	44.2k	1.5M	16.2k
10.5V to 24V	8.00V	2.2μF	10μF 1206	27.4k	AUX	800k	39.2k	1.5M	16.2k
13V to 24V	10.00V	2.2μF	10μF 1206	21.5k	AUX	900k	34.0k	1.3M	21.0k
18V to 36V	0.82V	2.2μF	200μF 1206	5.62M	≥2.8V, <25V	250k	150k	250k	150k
18V to 36V	1.00V	2.2μF	200μF 1206	953k	≥2.8V, <25V	300k	124k	300k	124k
18V to 36V	1.20V	2.2μF	147μF 1206	487k	≥2.8V, <25V	350k	105k	350k	105k
18V to 36V	1.50V	2.2μF	147μF 1206	280k	≥2.8V, <25V	400k	88.7k	400k	88.7k
18V to 36V	1.80V	2.2μF	100μF 1206	196k	≥2.8V, <25V	450k	78.7k	450k	78.7k
18V to 36V	2.00V	2.2μF	68μF 1206	165k	≥2.8V, <25V	450k	78.7k	450k	78.7k
18V to 36V	2.20V	2.2μF	47μF 1206	140k	≥2.8V, <25V	500k	69.8k	500k	69.8k
18V to 36V	2.50V	2.2μF	22μF 1206	115k	≥2.8V, <25V	550k	61.9k	600k	54.9k
18V to 36V	3.30V	2.2μF	22μF 1206	78.7k	AUX	600k	54.9k	700k	44.2k
18V to 36V	5.00V	2.2μF	10μF 1206	47.5k	AUX	700k	44.2k	1M	29.4k
18V to 36V	8.00V	2.2μF	10μF 1206	27.4k	AUX	800k	39.2k	1.5M	16.2k
18V to 36V	10.00V	2.2μF	10μF 1206	21.5k	AUX	900k	34.0k	1.3M	21.0k

Note: An input bulk capacitor is required. 200μF is 2 × 100μF, 147 is 100μF||47μF

APPLICATIONS INFORMATION

circuit they may have only a small fraction of their nominal capacitance resulting in much higher output voltage ripple than expected. Ceramic capacitors are also piezoelectric. In Burst Mode operation, the LTM8032's switching frequency depends on the load current, and can excite a ceramic capacitor at audio frequencies, generating audible noise. Since the LTM8032 operates at a lower current limit during Burst Mode operation, the noise is typically very quiet to a casual ear. If this audible noise is unacceptable, use a high performance electrolytic capacitor at the output. The input capacitor can be a parallel combination of a 2.2 μ F ceramic capacitor and a low cost electrolytic capacitor.

A final precaution regarding ceramic capacitors concerns the maximum input voltage rating of the LTM8032. A ceramic input capacitor combined with trace or cable inductance forms a high Q (under damped) tank circuit. If the LTM8032 circuit is plugged into a live supply, the input voltage can ring to twice its nominal value, possibly exceeding the device's rating. This situation is easily avoided; see the Hot-Plugging Safely section.

Electromagnetic Compliance

The LTM8032 is compliant with the radiated emissions requirements of EN55022 class B. Graphs of the LTM8032's EMC performance are given in the Typical Performance Characteristics section. Further data, operating conditions and test setup are detailed in an EMI Test report available from the Linear Technology website.

Frequency Selection

The LTM8032 uses a constant frequency PWM architecture that can be programmed to switch from 200kHz to 2.4MHz by using a resistor tied from the RT pin to ground. Table 2 provides a list of R_T resistor values and their resultant frequencies.

Operating Frequency Trade-Offs

It is recommended that the user apply the optimal R_T value given in Table 1 for the input and output operating condition. System level or other considerations, however, may necessitate another operating frequency. While the LTM8032 is flexible enough to accommodate a wide range of operating frequencies, a haphazardly chosen one may

Table 2. Switching Frequency vs R_T Value

SWITCHING FREQUENCY (MHz)	R_T VALUE (k Ω)
0.2	187
0.3	124
0.4	88.7
0.5	69.8
0.6	54.9
0.7	44.2
0.8	39.2
0.9	34
1.0	29.4
1.2	23.7
1.4	19.1
1.5	16.2
1.8	13.3
2	11.5
2.2	9.76
2.4	8.66

result in undesirable operation under certain operating or fault conditions. A frequency that is too high can reduce efficiency, generate excessive heat or even damage the LTM8032 if the output is overloaded or short-circuited. A frequency that is too low can result in a final design that has too much output ripple or too large of an output cap. The maximum frequency (and attendant R_T value) at which the LTM8032 should be allowed to switch is given in Table 1 in the f_{MAX} column, while the recommended frequency (and R_T value) for optimal efficiency over the given input condition is given in the $f_{OPTIMAL}$ column. There are additional conditions that must be satisfied if the synchronization function is used. Please refer to the Synchronization section for details.

BIAS Pin Considerations

The BIAS pin is used to provide drive power for the internal power switching stage and operate internal circuitry. For proper operation, it must be powered by at least 2.8V. If the output voltage is programmed to be 2.8V or higher, simply tie BIAS to AUX. If V_{OUT} is less than 2.8V, BIAS can be tied to V_{IN} or some other voltage source. In all cases, ensure that the maximum voltage at the BIAS pin is both less than 25V and the sum of V_{IN} and BIAS is less

APPLICATIONS INFORMATION

than 56V. If BIAS power is applied from a remote or noisy voltage source, it may be necessary to apply a decoupling capacitor locally to the LTM8032.

Load Sharing

Two or more LTM8032s may be paralleled to produce higher currents. This may, however, alter the EMI performance of the LTM8032s. To do this, tie the V_{IN} , ADJ, V_{OUT} and SHARE pins of all the paralleled LTM8032s together. To ensure that paralleled modules start up together, the RUN/SS pins may be tied together, as well. Synchronize the LTM8032s to an external clock to eliminate beat frequencies, if required. If the RUN/SS pins are not tied together, make sure that the same valued soft-start capacitors are used for each module. An example of two LTM8032 modules configured for load sharing is given in the Typical Applications section.

For current sharing applications using multiple LTM8032s, the ADJ pins for all regulators may be combined using one resistor to ground as determined by:

$$R_{ADJ} = \frac{196.71}{N} \cdot \frac{1}{V_{OUT} - 0.79}$$

where N is the number of paralleled modules and R_{ADJ} is in $k\Omega$.

Burst Mode Operation

To enhance efficiency at light loads, the LTM8032 automatically switches to Burst Mode operation which keeps the output capacitor charged to the proper voltage while minimizing the input quiescent current. During Burst Mode operation, the LTM8032 delivers single cycle bursts of current to the output capacitor followed by sleep periods where the output power is delivered to the load by the output capacitor. In addition, V_{IN} and BIAS quiescent currents are reduced to typically $25\mu A$ and $60\mu A$ respectively during the sleep time. As the load current decreases towards a no-load condition, the percentage of time that the LTM8032 operates in sleep mode increases and the average input current is greatly reduced, resulting in higher efficiency. Burst Mode operation is enabled by tying SYNC to GND.

To disable Burst Mode operation, tie SYNC to a stable voltage above 0.7V or synchronize to an external clock. Do not leave the SYNC pin floating.

Minimum Input Voltage

The LTM8032 is a step-down converter, so a minimum amount of headroom is required to keep the output in regulation. In addition, the input voltage required to turn on is higher than that required to run, and depends upon whether the RUN/SS is used. As shown in Figure 1, it takes only about $3.6V_{IN}$ for the LTM8032 to run a 3.3V output at light load. If RUN/SS is tied directly to V_{IN} , a 5.5V input voltage is required to start. If V_{IN} is allowed to settle in the operating region first then the RUN/SS pin is enabled, the minimum input voltage to start at light load is lower, about 4.7V. A similar curve for 5V_{OUT} operation is also provided in Figure 1.

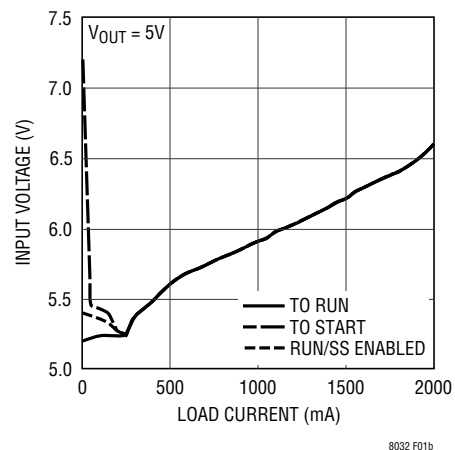
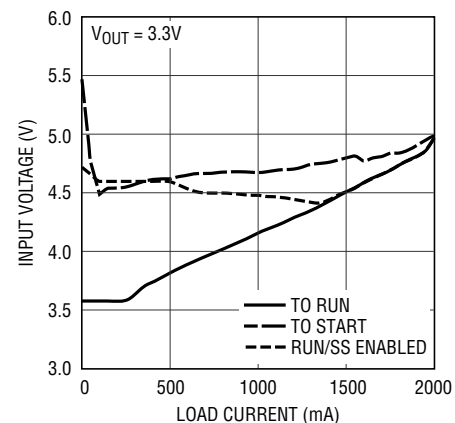

Figure 1. The LTM8032 Needs More Voltage to Start Than Run

APPLICATIONS INFORMATION

Soft-Start

The RUN/SS pin can be used to soft-start the LTM8032, reducing the maximum input current during start-up. The RUN/SS pin is driven through an external RC network to create a voltage ramp at this pin. Figure 2 shows the start-up and shutdown waveforms with the soft-start circuit. By choosing an appropriate RC time constant, the peak start-up current can be reduced to the current that is required to regulate the output, with no overshoot. Choose the value of the resistor so that it can supply at least 20 μ A when the RUN/SS pin reaches 2.5V.

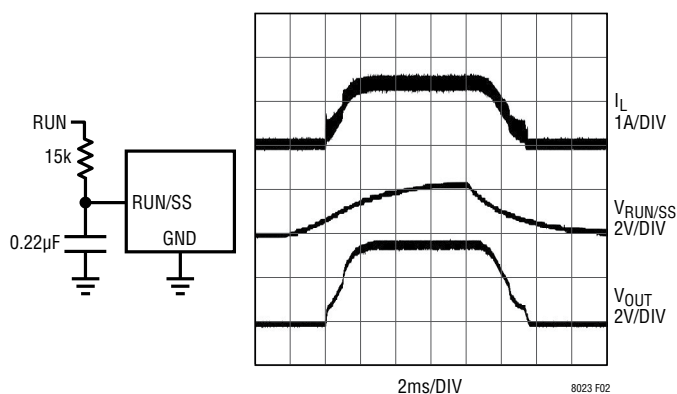

Figure 2. To Soft-Start the LTM8032, Add a Resistor and Capacitor to the RUN/SS Pin

Synchronization

The internal oscillator of the LTM8032 can be synchronized by applying an external 250kHz to 2MHz clock to the SYNC pin. Do not leave this pin floating. The resistor tied from the RT pin to ground should be chosen such that the LTM8032 oscillates 20% lower than the intended synchronization frequency (see the Frequency Selection section). The LTM8032 will not enter Burst Mode operation while synchronized to an external clock, but will instead skip pulses to maintain regulation.

Shorted Input Protection

Care needs to be taken in systems where the output will be held high when the input to the LTM8032 is absent. This may occur in battery charging applications or in battery back-up systems where a battery or some other supply is diode ORed with the LTM8032's output. If the V_{IN} pin is allowed to float and the RUN/SS pin is held high (either by a logic signal or because it is tied to V_{IN}), then the LTM8032's internal circuitry will pull its quiescent current through its internal power switch. This is fine if your system can tolerate a few milliamps in this state. If you ground the RUN/SS pin, the internal switch current will drop to essentially zero. However, if the V_{IN} pin is grounded while the output is held high, then parasitic diodes inside the LTM8032 can pull large currents from the output through the V_{IN} pin, potentially damaging the device. Figure 3 shows a circuit that will run only when the input voltage is present and that protects against a shorted or reversed input.

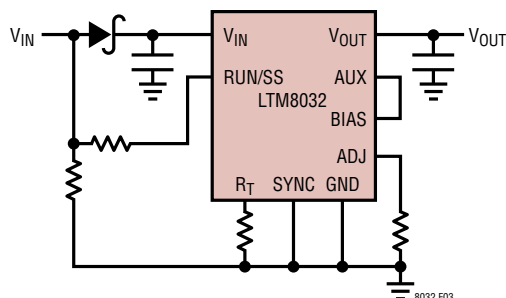

Figure 3. The Input Diode Prevents a Shorted Input from Discharging a Back-Up Battery Tied to the Output. It Also Protects the Circuit from a Reversed Input. The LTM8032 Runs Only When the Input is Present

APPLICATIONS INFORMATION

PCB Layout

Most of the headaches associated with PCB layout have been alleviated or even eliminated by the high level of integration of the LTM8032. The LTM8032 is nevertheless a switching power supply and care must be taken to minimize EMI and ensure proper operation. Even with the high level of integration, you may fail to achieve specified operation with a haphazard or poor layout. See Figure 4 for a suggested layout.

Ensure that the grounding and heat sinking are acceptable. A few rules to keep in mind are:

1. Place the R_{ADJ} and R_T resistors as close as possible to their respective pins.
2. Place the C_{IN} capacitor as close as possible to the V_{IN} and GND connection of the LTM8032. If a capacitor is connected to the FIN terminals, place it as close as possible to the FIN terminals, such that its ground connection is as close as possible to that of the C_{IN} capacitor.
3. Place the C_{OUT} capacitor as close as possible to the V_{OUT} and GND connection of the LTM8032.
4. Place the C_{IN} and C_{OUT} capacitors such that their ground currents flow directly adjacent or underneath the LTM8032.
5. Connect all of the GND connections to as large a copper pour or plane area as possible on the top layer. Avoid breaking the ground connection between the external components and the LTM8032.
6. Use vias to connect the GND copper area to the board's internal ground plane. Liberally distribute these GND vias to provide both a good ground connection and thermal path to the internal planes of the printed circuit board.

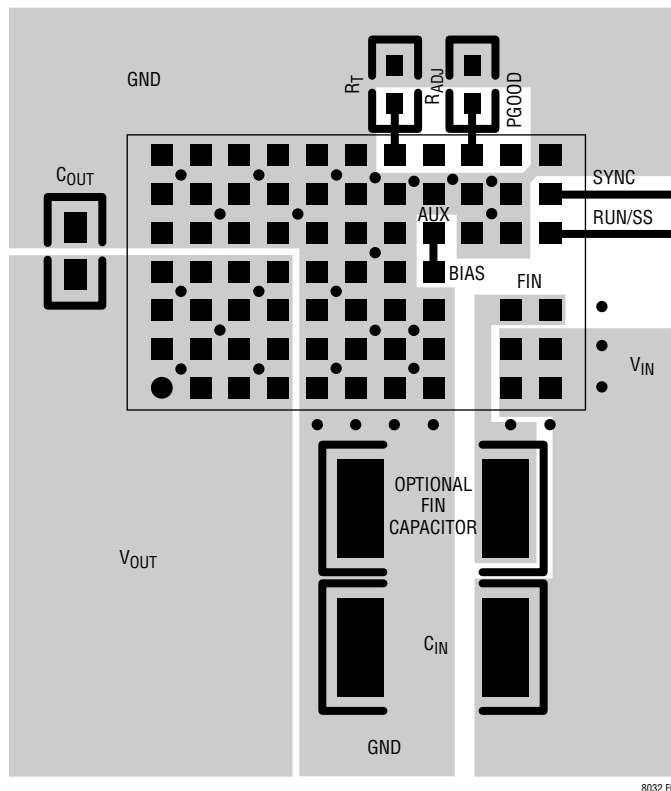

Figure 4. Layout Showing Suggested External Components, GND Plane and Thermal Vias (LGA Package)

APPLICATIONS INFORMATION

Hot-Plugging Safely

The small size, robustness and low impedance of ceramic capacitors make them an attractive option for the input bypass capacitor of LTM8032. However, these capacitors can cause problems if the LTM8032 is plugged into a live or fast rising or falling supply (see Linear Technology Application Note 88 for a complete discussion). The low loss ceramic capacitor combined with stray inductance in series with the power source forms an under-damped tank circuit, and the voltage at the V_{IN} pin of the LTM8032 can ring to twice the nominal input voltage, possibly exceeding the LTM8032's rating and damaging the part. A similar phenomenon can occur inside the LTM8032 module, at the output of the integrated EMI filter, with the same potential of damaging the part.

If the input supply is poorly controlled or the user will be plugging the LTM8032 into an energized supply, the input network should be designed to prevent this overshoot. Figure 5 shows the waveforms that result when an LTM8032 circuit is connected to a 24V supply through six feet of 24-gauge twisted pair. The first plot (5a) is the response

with a 2.2 μ F ceramic capacitor at the input. The input voltage rings as high as 35V and the input current peaks at 20A. One method of damping the tank circuit is to add another capacitor with a series resistor to the circuit. An alternative solution is shown in Figure 5b. A 0.7 Ω resistor is added in series with the input to eliminate the voltage overshoot (it also reduces the peak input current). A 0.1 μ F capacitor improves high frequency filtering. For high input voltages its impact on efficiency is minor, reducing efficiency less than one-half percent for a 5V output at full load operating from 24V. By far the most popular method of controlling overshoot is shown in Figure 5c, where an aluminum electrolytic capacitor has been connected to FIN. This capacitor's high equivalent series resistance damps the circuit and eliminates the voltage overshoot. The extra capacitor improves low frequency ripple filtering and can slightly improve the efficiency of the circuit, though it is likely to be the largest component in the circuit. Figure 5c shows the capacitor added to the V_{IN} terminals, but placing the electrolytic capacitor at the FIN terminals can improve the LTM8032's EMI filtering as well as guard against overshoots caused by the Q of the integrated filter.

APPLICATIONS INFORMATION

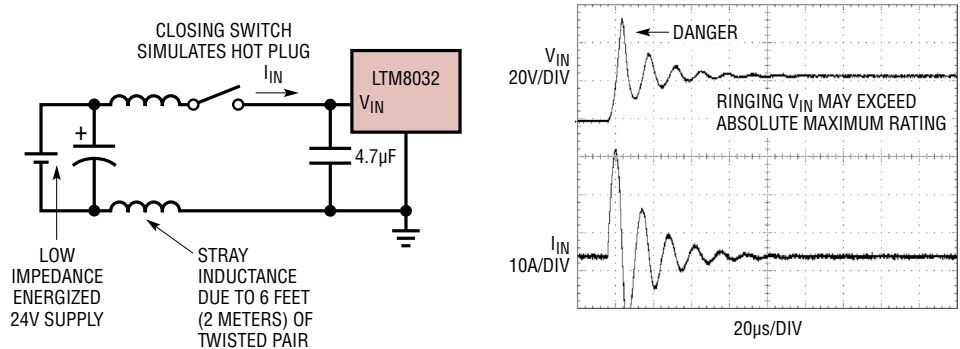

(5a)

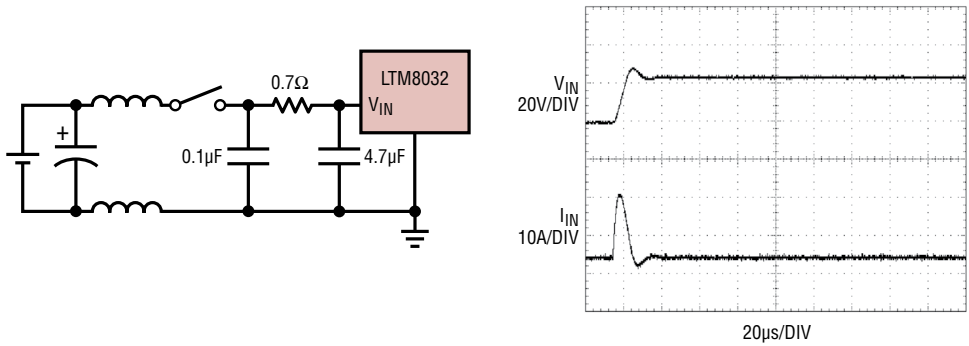

(5b)

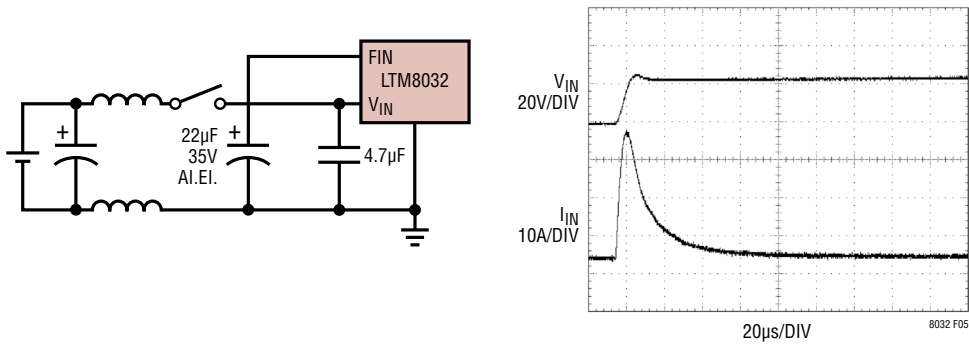

(5c)

Figure 5. A Well Chosen Input Network Prevents Input Voltage Overshoot and Ensures Reliable Operation When the LTM8032 is Hot-Plugged to a Live Supply

APPLICATIONS INFORMATION

Thermal Considerations

The LTM8032 output current may need to be derated if it is required to operate in a high ambient temperature or deliver a large amount of continuous power. The amount of current derating is dependent upon the input voltage, output power and ambient temperature. The temperature rise curves given in the Typical Performance Characteristics section can be used as a guide. These curves were generated by an LTM8032 mounted to a 36cm² 4-layer FR4 printed circuit board. Boards of other sizes and layer count can exhibit different thermal behavior, so it is incumbent upon the user to verify proper operation over the intended system's line, load and environmental operating conditions.

The thermal resistance numbers listed in the Pin Configuration are based on modeling the μ Module package mounted on a test board specified per JESD51-9 "Test Boards for Area Array Surface Mount Package Thermal Measurements." The thermal coefficients provided in this page are based on JESD 51-12 "Guidelines for Reporting and Using Electronic Package Thermal Information."

For increased accuracy and fidelity to the actual application, many designers use FEA to predict thermal performance. To that end, the Pin Configuration typically gives four thermal coefficients:

- θ_{JA} – Thermal resistance from junction to ambient.
- $\theta_{JCbottom}$ – Thermal resistance from junction to the bottom of the product case.
- θ_{JCtop} – Thermal resistance from junction to top of the product case.
- θ_{JB} – Thermal resistance from junction to the printed circuit board.

While the meaning of each of these coefficients may seem to be intuitive, JEDEC has defined each to avoid confusion and inconsistency. These definitions are given in JESD 51-12, and are quoted or paraphrased in the following:

- θ_{JA} is the natural convection junction-to-ambient air thermal resistance measured in a one cubic foot sealed enclosure. This environment is sometimes referred to as "still air" although natural convection causes the air to move. This value is determined with the part mounted to a JESD 51-9 defined test board, which does not reflect an actual application or viable operating condition.
- $\theta_{JCbottom}$ is the junction-to-board thermal resistance with all of the component power dissipation flowing through the bottom of the package. In the typical μ Module regulator, the bulk of the heat flows out the bottom of the package, but there is always heat flow out into the ambient environment. As a result, this thermal resistance value may be useful for comparing packages but the test conditions don't generally match the user's application.
- θ_{JCtop} is determined with nearly all of the component power dissipation flowing through the top of the package. As the electrical connections of the typical μ Module regulator are on the bottom of the package, it is rare for an application to operate such that most of the heat flows from the junction to the top of the part. As in the case of $\theta_{JCbottom}$, this value may be useful for comparing packages but the test conditions don't generally match the user's application.
- θ_{JB} is the junction-to-board thermal resistance where almost all of the heat flows through the bottom of the μ Module regulator and into the board, and is really the sum of the $\theta_{JCbottom}$ and the thermal resistance of the bottom of the part through the solder joints and through a portion of the board. The board temperature is measured a specified distance from the package, using a two sided, two layer board. This board is described in JESD 51-9.

APPLICATIONS INFORMATION

The most appropriate way to use the coefficients is when running a detailed thermal analysis, such as FEA, which considers all of the thermal resistances simultaneously. None of them can be individually used to accurately predict the thermal performance of the product, so it would be inappropriate to attempt to use any one coefficient to correlate to the junction temperature versus load graphs given in the LTM8032 data sheet.

A graphical representation of these thermal resistances is given in Figure 6.

The blue resistances are contained within the μ Module regulator, and the green are outside.

The die temperature of the LTM8032 must be lower than the maximum rating of 125°C, so care should be taken in the layout of the circuit to ensure good heat sinking of the LTM8032. The bulk of the heat flow out of the LTM8032 is through the bottom of the module and the pads into the printed circuit board. Consequently a poor printed circuit board design can cause excessive heating, resulting in impaired performance or reliability. Please refer to the PCB Layout section for printed circuit board design suggestions.

Finally, be aware that at high ambient temperatures the internal Schottky diode will have significant leakage current increasing the quiescent current of the LTM8032.

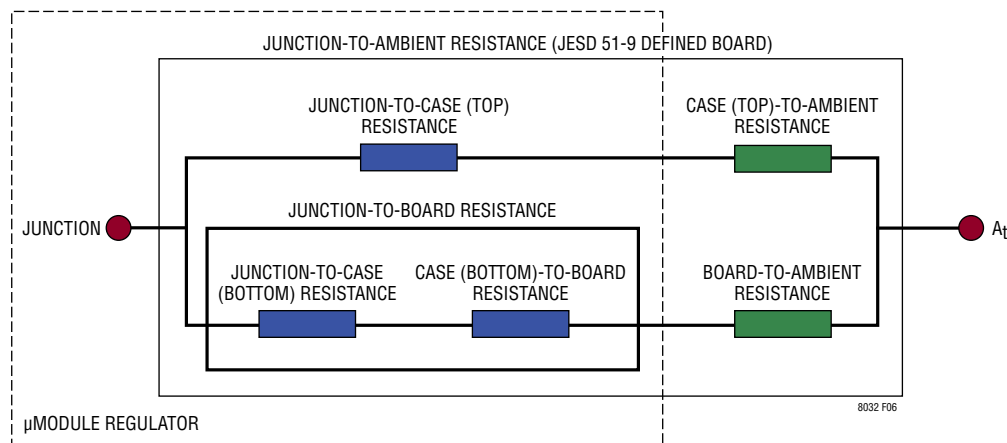
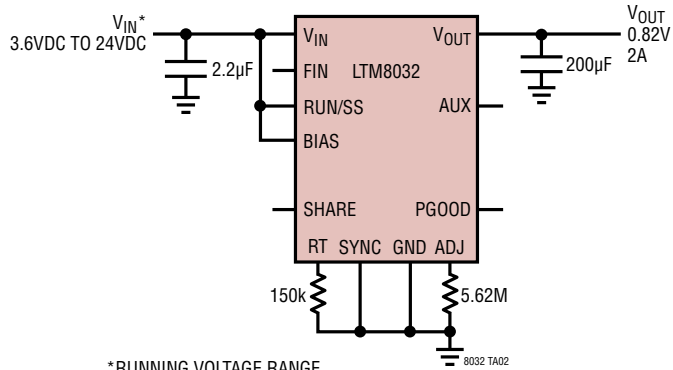

Figure 6

TYPICAL APPLICATIONS

0.82V Step-Down Converter



*RUNNING VOLTAGE RANGE.
SEE APPLICATIONS FOR START-UP DETAILS

1.8V Step-Down Converter

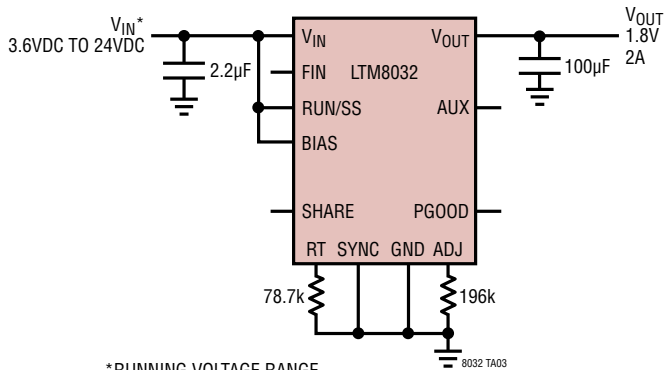

*RUNNING VOLTAGE RANGE.
SEE APPLICATIONS FOR START-UP DETAILS

TYPICAL APPLICATIONS

2.5V Step-Down Converter

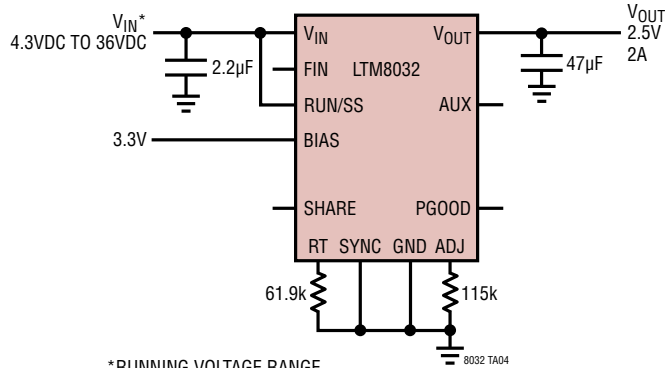

*RUNNING VOLTAGE RANGE.
SEE APPLICATIONS FOR START-UP DETAILS

3.3V Step-Down Converter

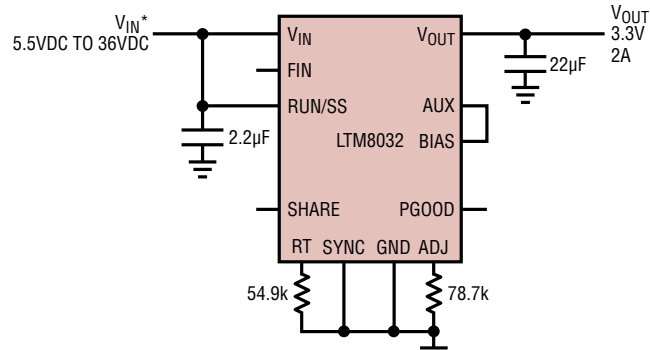

*RUNNING VOLTAGE RANGE.
SEE APPLICATIONS FOR START-UP DETAILS

5V Step-Down Converter

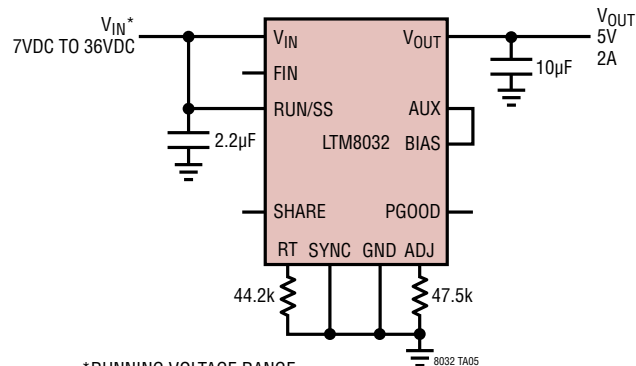

*RUNNING VOLTAGE RANGE.
SEE APPLICATIONS FOR START-UP DETAILS

TYPICAL APPLICATIONS

8V Step-Down Converter

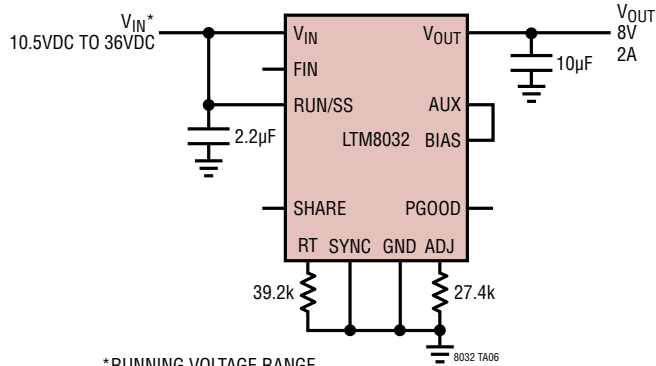

*RUNNING VOLTAGE RANGE.
SEE APPLICATIONS FOR START-UP DETAILS

Two LTM8032s Operating in Parallel

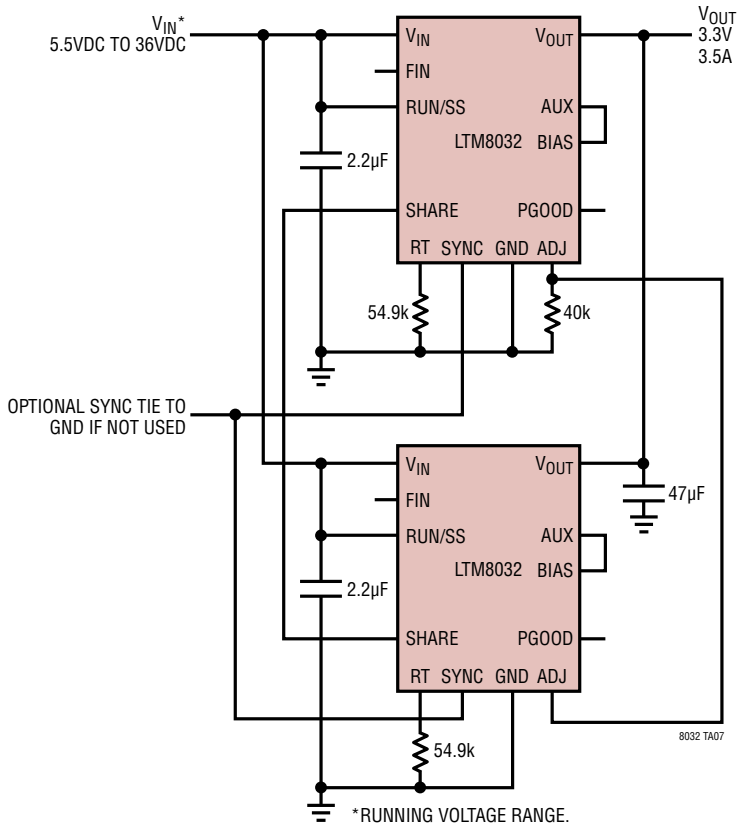

*RUNNING VOLTAGE RANGE.
SEE APPLICATIONS FOR START-UP DETAILS

PACKAGE DESCRIPTION

Please refer to <http://www.linear.com/designtools/packaging/> for the most recent package drawings.

LGA Package 71-Lead (15mm × 9mm × 2.82mm) (Reference LTC DWG # 05-08-1823 Rev A)

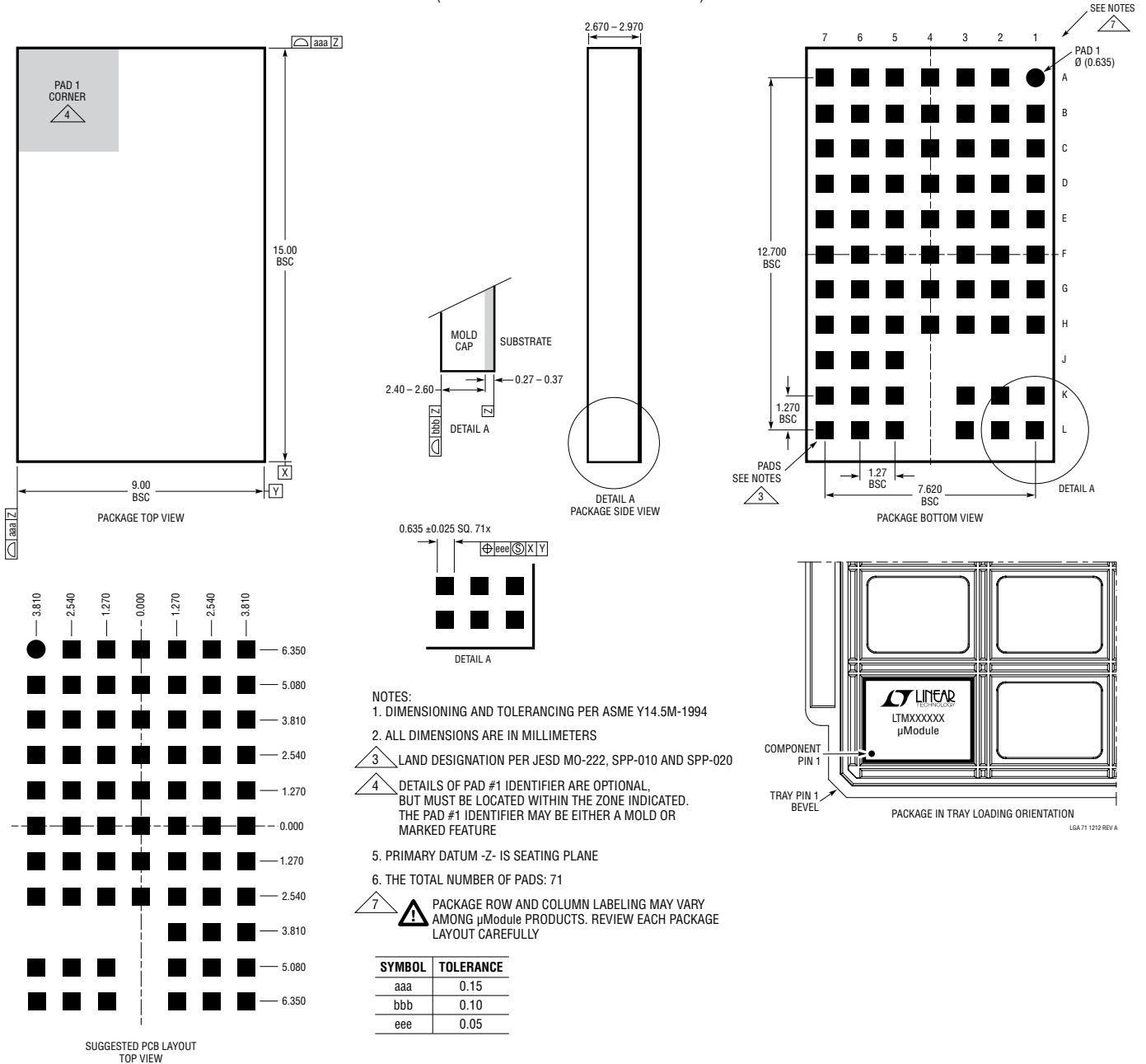

PACKAGE DESCRIPTION

Please refer to <http://www.linear.com/designtools/packaging/> for the most recent package drawings.

BGA Package 71-Lead (15mm × 9.00mm × 3.42mm) (Reference LTC DWG # 05-08-1885 Rev A)

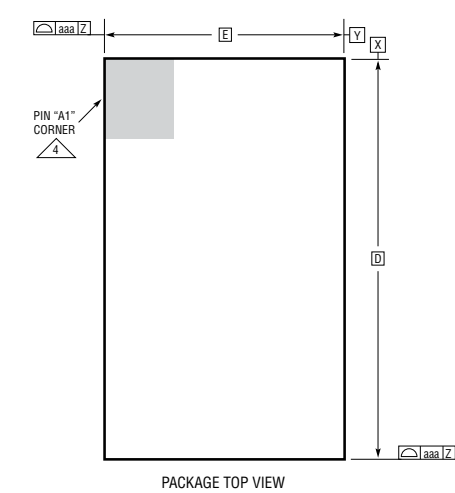

PACKAGE TOP VIEW

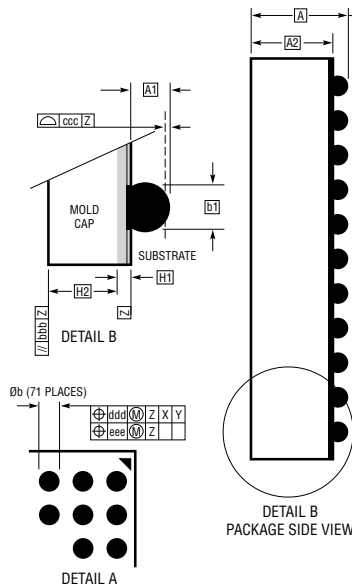

DIMENSIONS				
SYMBOL	MIN	NOM	MAX	NOTES
A	3.22	3.42	3.62	
A1	0.50	0.60	0.70	
A2	2.72	2.82	2.92	
b	0.71	0.78	0.85	
b1	0.60	0.63	0.66	
D	15.0			
E	9.0			
e	1.27			
F	12.7			
G	7.62			
H1	0.27	0.32	0.37	
H2	2.45	2.50	2.55	
aaa			0.15	
bbb			0.10	
ccc			0.20	
ddd			0.30	
eee			0.15	

TOTAL NUMBER OF BALLS: 71

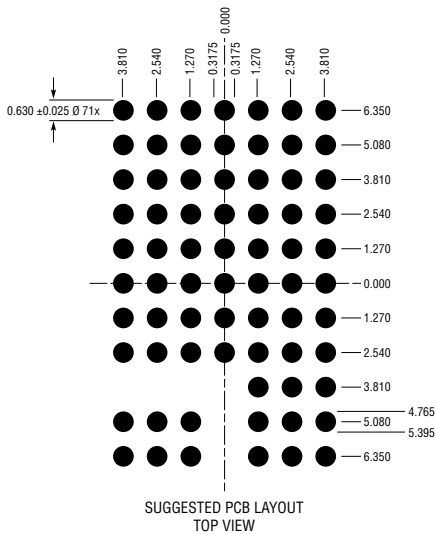

SUGGESTED PCB LAYOUT TOP VIEW

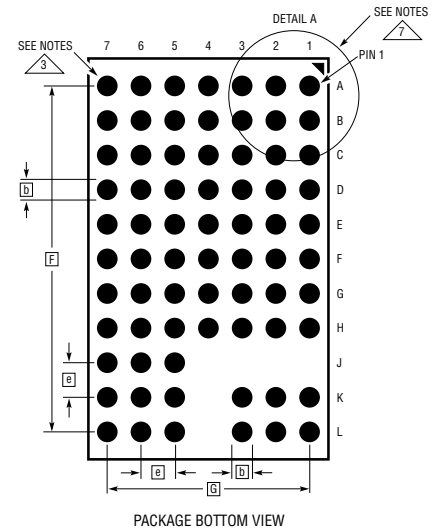

PACKAGE BOTTOM VIEW

- NOTES:
1. DIMENSIONING AND TOLERANCING PER ASME Y14.5M-1994
 2. ALL DIMENSIONS ARE IN MILLIMETERS
 3. BALL DESIGNATION PER JESD MS-028 AND JEP95
 4. DETAILS OF PIN #1 IDENTIFIER ARE OPTIONAL, BUT MUST BE LOCATED WITHIN THE ZONE INDICATED. THE PIN #1 IDENTIFIER MAY BE EITHER A MOLD OR MARKED FEATURE
 5. PRIMARY DATUM -Z- IS SEATING PLANE
 6. SOLDER BALL COMPOSITION CAN BE 96.5% Sn/3.0% Ag/0.5% Cu OR Sn Pb EUTECTIC
 7. PACKAGE ROW AND COLUMN LABELING MAY VARY AMONG μ Module PRODUCTS. REVIEW EACH PACKAGE LAYOUT CAREFULLY

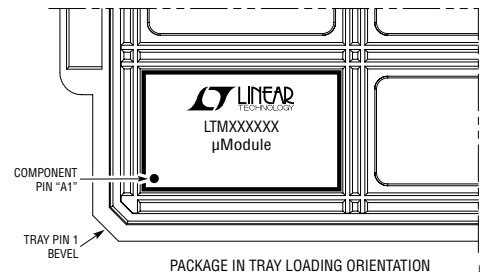

PACKAGE IN TRAY LOADING ORIENTATION

BGA 71 1212 REV A

PACKAGE DESCRIPTION

Table 3. LTM8032 Pinout (Sorted by Pin Number)

PIN	SIGNAL DESCRIPTION	PIN	SIGNAL DESCRIPTION
A1	V _{OUT}	E7	GND
A2	V _{OUT}	F1	GND
A3	V _{OUT}	F2	GND
A4	V _{OUT}	F3	GND
A5	GND	F4	GND
A6	GND	F5	GND
A7	GND	F6	GND
B1	V _{OUT}	F7	GND
B2	V _{OUT}	G1	GND
B3	V _{OUT}	G2	GND
B4	V _{OUT}	G3	GND
B5	GND	G4	GND
B6	GND	G5	GND
B7	GND	G6	GND
C1	V _{OUT}	G7	RT
C2	V _{OUT}	H1	GND
C3	V _{OUT}	H2	GND
C4	V _{OUT}	H3	GND
C5	GND	H4	BIAS
C6	GND	H5	AUX
C7	GND	H6	GND
D1	V _{OUT}	H7	SHARE
D2	V _{OUT}	J5	GND
D3	V _{OUT}	J6	GND
D4	V _{OUT}	J7	ADJ
D5	GND	K1	V _{IN}
D6	GND	K2	V _{IN}
D7	GND	K3	FIN
E1	GND	K5	GND
E2	GND	K6	GND
E3	GND	K7	PGOOD
E4	GND	L1	V _{IN}
E5	GND	L2	V _{IN}
E6	GND	L3	FIN
		L5	RUN/SS
		L6	SYNC
		L7	GND

REVISION HISTORY (Revision history begins at Rev D)

REV	DATE	DESCRIPTION	PAGE NUMBER
D	8/11	Added BGA package. Changes reflected throughout the data sheet.	1 to 26
E	9/11	Updated BGA Pin Configuration diagram.	2
F	2/12	Indicate Figure 4 is Layout Example for LGA Package	14
		Consolidate BGA and LGA Pinout Table	24
G	1/14	Added SnPb terminal finish product option	1, 2

PACKAGE PHOTOGRAPHS

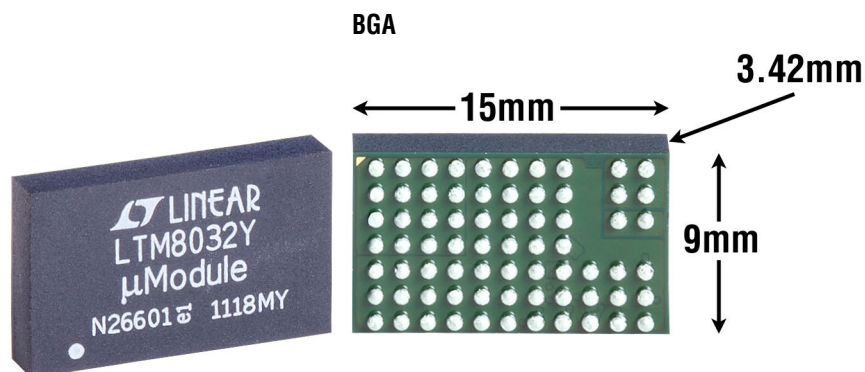
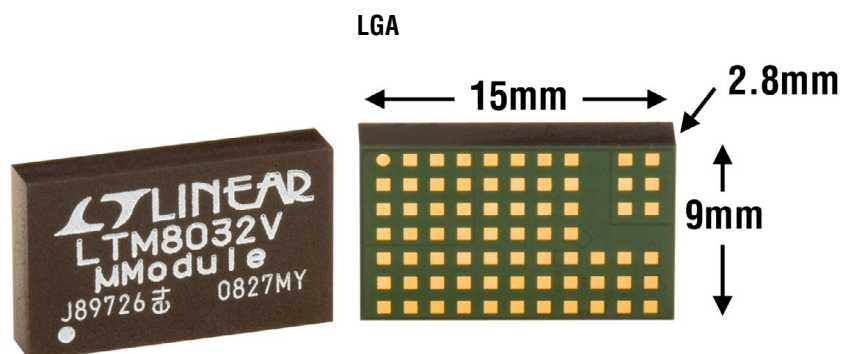

RELATED PARTS

PART NUMBER	DESCRIPTION	COMMENTS
LTM8033	EN55022B Certified 36V, 3A Step-Down μModule Regulator	$0.8V \leq V_{OUT} \leq 24V$, Synchronizable, 11.25mm × 15mm × 4.3mm LGA
LTM4606	EN55022B Certified 28V, 6A Step-Down μModule Regulator	$0.6V \leq V_{OUT} \leq 5V$, Synchronizable, 15mm × 15mm × 2.8mm LGA
LTM4612	EN55022B Certified 36V, 5A Step-Down μModule Regulator	$3.3V \leq V_{OUT} \leq 15V$, Synchronizable, 15mm × 15mm × 2.8mm LGA
LTM4613	EN55022B Certified 36V, 8A Step-Down μModule Regulator	$3.3V \leq V_{OUT} \leq 15V$, Synchronizable, 15mm × 15mm × 4.3mm LGA
LTM8023	36V, 2A Step-Down μModule Regulator	$0.8V \leq V_{OUT} \leq 10V$, Synchronizable, 9mm × 11.25mm × 2.8mm LGA



Компания «ЭлектроПласт» предлагает заключение долгосрочных отношений при поставках импортных электронных компонентов на взаимовыгодных условиях!

Наши преимущества:

- Оперативные поставки широкого спектра электронных компонентов отечественного и импортного производства напрямую от производителей и с крупнейших мировых складов;
- Поставка более 17-ти миллионов наименований электронных компонентов;
- Поставка сложных, дефицитных, либо снятых с производства позиций;
- Оперативные сроки поставки под заказ (от 5 рабочих дней);
- Экспресс доставка в любую точку России;
- Техническая поддержка проекта, помощь в подборе аналогов, поставка прототипов;
- Система менеджмента качества сертифицирована по Международному стандарту ISO 9001;
- Лицензия ФСБ на осуществление работ с использованием сведений, составляющих государственную тайну;
- Поставка специализированных компонентов (Xilinx, Altera, Analog Devices, Intersil, Interpoint, Microsemi, Aeroflex, Peregrine, Syfer, Eurofarad, Texas Instrument, Miteq, Cobham, E2V, MA-COM, Hittite, Mini-Circuits, General Dynamics и др.);

Помимо этого, одним из направлений компании «ЭлектроПласт» является направление «Источники питания». Мы предлагаем Вам помощь Конструкторского отдела:

- Подбор оптимального решения, техническое обоснование при выборе компонента;
- Подбор аналогов;
- Консультации по применению компонента;
- Поставка образцов и прототипов;
- Техническая поддержка проекта;
- Защита от снятия компонента с производства.



Как с нами связаться

Телефон: 8 (812) 309 58 32 (многоканальный)

Факс: 8 (812) 320-02-42

Электронная почта: org@eplast1.ru

Адрес: 198099, г. Санкт-Петербург, ул. Калинина, дом 2, корпус 4, литера А.