

# XB Supercapacitors

## Cylindrical snap-in



### Features

- Over 10-year operating life at room temperature
- Low ESR for high power density
- Large capacitance for high energy density
- Long cycle life
- Environmentally friendly electrolyte
- UL Recognized

### Applications

- Hybrid battery or fuel cell systems
- High pulse current applications
- UPS / hold-up power

### Description

Eaton supercapacitors are unique, ultra-high capacitance devices utilizing electrochemical double layer capacitor (EDLC) construction combined with new, high performance materials. This combination of advanced technologies allows Eaton to offer a wide variety of capacitor solutions tailored to specific applications that range from a few micro-amps for several days to several amps for milliseconds.

## Ratings

Capacitance	300 F to 600 F
Maximum working voltage	2.5 V
Surge voltage	2.85 V
Capacitance tolerance	-10% to +10% (+20 °C)
Operating temperature range	-25 °C to +70 °C

## Specifications

Capacitance <sup>1</sup> (F)	Part Number	Maximum ESR <sup>1</sup> (mΩ) (Equivalent Series Resistance)	Max continuous current <sup>2</sup> (A)	Peak current <sup>3</sup> (A)	Max leakage current <sup>1,4</sup> (mA)	Max power <sup>5</sup> (W)	Stored energy <sup>6</sup> (Wh)	Typical mass (g)
300	XB3550-2R5307-R	7	15	120	0.30	220	0.26	69
400	XB3560-2R5407-R	4.5	19	180	0.45	350	0.35	80
600	XB3585-2R5607-R	3.7	29	235	0.70	420	0.52	122

1. Capacitance, ESR and Leakage current are all measured according to IEC 62391-1 at +20 °C
2. 15 °C Temperature Rise
3. Peak Current is for 1 second =  $\frac{1}{2}$  Working Voltage x Capacitance / (1 + ESR x Capacitance)
4. Leakage current measured after 72 hours, +20 °C
5. Max. Power = Working Voltage<sup>2</sup> / 4 / ESR
6. Stored energy =  $\frac{1}{2}$  Capacitance x Working Voltage<sup>2</sup> / 3600

## Performance

Parameter		Capacitance change (% of initial value)	ESR (% of max. initial value)
Life			
@ Maximum operating voltage and temp)	1500 hours	≤ 20%	≤ 200%
Charge/discharge cycling <sup>1</sup>	500,000	≤ 20%	≤ 200%
Storage Life- uncharged			
-25 °C to +70 °C	1500 hours	≤ 20%	≤ 200%
≤ 30°C	3 years	≤ 5%	≤ 10%

1. Cycling between maximum operating and 50% of maximum operating voltage at room temperature

**Dimensions- mm**

**Dimensions - mm**

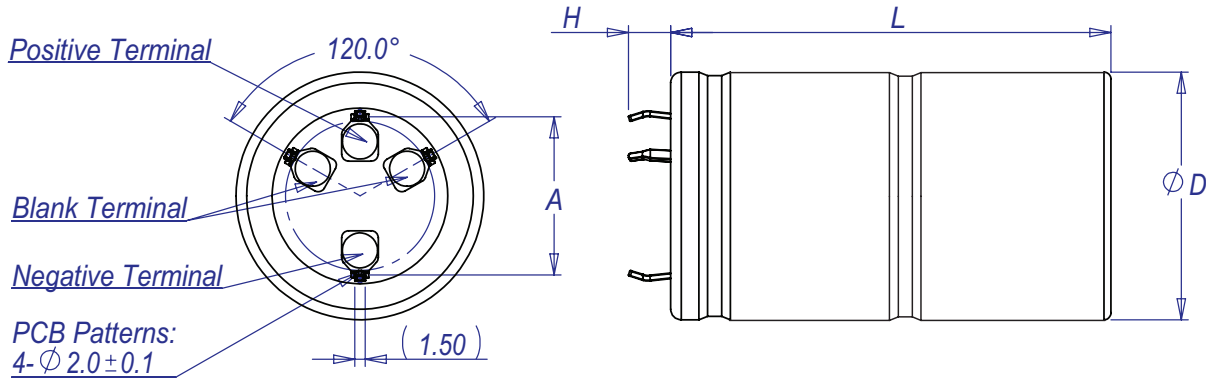

Part number	D $\pm 1.0$	L $\pm 1.0$	H $\pm 1.0$	A $\pm 0.1$
XB3550-2R5307-R	35	53	6	22.5
XB3560-2R5407-R	35	63	6	22.5
XB3585-2R5607-R	35	87.5	6	22.5

**Part numbering system**

<b>XB</b>	<b>3560</b>		<b>-2R5</b>	<b>40</b>	<b>7</b>	<b>-R</b>
Family Code	Size reference- mm		Voltage (V) R = Decimal	Capacitance ( $\mu$ F)		Standard product
	Diameter	Length		Value	Multiplier	
XB=Family Code	35	60	2R5 = 2.5 V	Example: 407 = 40 x 10 <sup>7</sup> $\mu$ F or 400 F		

**Packaging information**

- Standard packaging: Bulk, 20 parts per box

**Part marking**

- Manufacturer
- Capacitance (F)
- Maximum operating voltage (V)
- Family code (or part number)
- Polarity

**Wave solder profile**

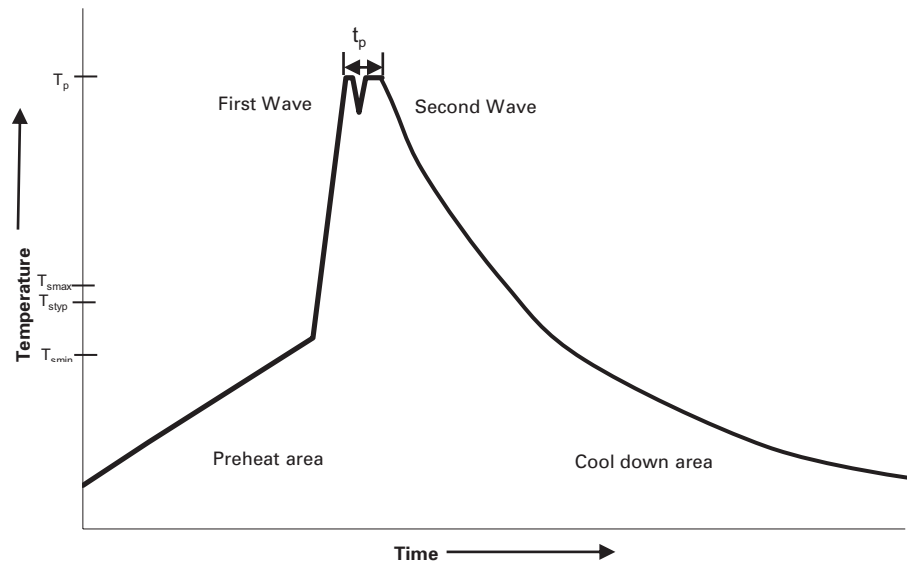

Profile Feature	Standard SnPb Solder	Lead (Pb) Free Solder
Preheat and soak	• Temperature max. ( $T_{smax}$ ) • Time max.	100 °C 60 seconds
$\Delta$ preheat to max Temperature	160 °C max.	160 °C max.
Peak temperature ( $T_p$ )*	220 °C – 260 °C	250 °C – 260 °C
Time at peak temperature ( $t_p$ )	10 seconds max 5 seconds max each wave	10 seconds max 5 seconds max each wave
Ramp-down rate	~ 2 K/s min ~3.5 K/s typ ~5 K/s max	~ 2 K/s min ~3.5 K/s typ ~5 K/s max
Time 25 °C to 25 °C	4 minutes	4 minutes

**Manual solder**

+350 °C, 4-5 seconds. (by soldering iron), generally manual, hand soldering is not recommended.

**Reflow soldering**

Do not use reflow soldering using infrared or convection oven heating methods.

**Cleaning/Washing**

Avoid cleaning of circuit boards, however if the circuit board must be cleaned use static or ultrasonic immersion in a standard circuit board cleaning fluid for no more than 5 minutes and a maximum temperature of +60 °C. Afterwards thoroughly rinse and dry the circuit boards. In general, treat supercapacitors in the same manner you would an aluminum electrolytic capacitor.

Life Support Policy: Eaton does not authorize the use of any of its products for use in life support devices or systems without the express written approval of an officer of the Company. Life support systems are devices which support or sustain life, and whose failure to perform, when properly used in accordance with instructions for use provided in the labeling, can be reasonably expected to result in significant injury to the user.

Eaton reserves the right, without notice, to change design or construction of any products and to discontinue or limit distribution of any products. Eaton also reserves the right to change or update, without notice, any technical information contained in this bulletin.

**Eaton**  
**Electronics Division**  
1000 Eaton Boulevard  
Cleveland, OH 44122  
United States  
www.eaton.com/electronics

© 2017 Eaton  
All Rights Reserved  
Printed in USA  
Publication No. 4423  
October 2017

Eaton is a registered trademark.  
All other trademarks are property of their respective owners.



Компания «ЭлектроПласт» предлагает заключение долгосрочных отношений при поставках импортных электронных компонентов на взаимовыгодных условиях!

Наши преимущества:

- Оперативные поставки широкого спектра электронных компонентов отечественного и импортного производства напрямую от производителей и с крупнейших мировых складов;
- Поставка более 17-ти миллионов наименований электронных компонентов;
- Поставка сложных, дефицитных, либо снятых с производства позиций;
- Оперативные сроки поставки под заказ (от 5 рабочих дней);
- Экспресс доставка в любую точку России;
- Техническая поддержка проекта, помощь в подборе аналогов, поставка прототипов;
- Система менеджмента качества сертифицирована по Международному стандарту ISO 9001;
- Лицензия ФСБ на осуществление работ с использованием сведений, составляющих государственную тайну;
- Поставка специализированных компонентов (Xilinx, Altera, Analog Devices, Intersil, Interpoint, Microsemi, Aeroflex, Peregrine, Syfer, Eurofarad, Texas Instrument, Miteq, Cobham, E2V, MA-COM, Hittite, Mini-Circuits, General Dynamics и др.);

Помимо этого, одним из направлений компании «ЭлектроПласт» является направление «Источники питания». Мы предлагаем Вам помощь Конструкторского отдела:

- Подбор оптимального решения, техническое обоснование при выборе компонента;
- Подбор аналогов;
- Консультации по применению компонента;
- Поставка образцов и прототипов;
- Техническая поддержка проекта;
- Защита от снятия компонента с производства.



#### Как с нами связаться

**Телефон:** 8 (812) 309 58 32 (многоканальный)

**Факс:** 8 (812) 320-02-42

**Электронная почта:** [org@eplast1.ru](mailto:org@eplast1.ru)

**Адрес:** 198099, г. Санкт-Петербург, ул. Калинина, дом 2, корпус 4, литера А.