

Emergency stop and safety guard monitoring 2 channels KNE3-YS Part number 85102435



- "Emergency stop" & "Safety gates monitoring" functions
- Single and 2-channel operation
- Security with redundancy and feedback circuit
- 3 "NO" security contacts
- 1 "NC" monitoring contact
- Security category 4 (according to EN 954-1)
- Performance Level (PL) e, safety category 4 to EN ISO 13849-1
- SIL Claimed Level (SIL CL) 3 to IEC/EN 62061
- Terminals : fixed screw terminals or plugin cage clamp terminals

Part numbers

	Type	Terminals	Voltages	Supply frequency range (Hz)	Outputs
85102435	KNE3-YS	Screws	230 VAC	50/60	3 NO + 1 NC

Specifications

Operating characteristics

Functions	Emergency stop Safety gates monitoring
Operation	1 or 2 channels
Control input	Manual restart with On-button (Y1 - Y2 terminals) Automatic restart (switch S2 & Y1 - Y2 linked)
Failure detection	Monitored start on On-button With or without cross fault monitoring in the emergency-stop loop (switch S1)
Display of output state by LED	Power supply : PWR Output : OUT1 (relay K1) Output : OUT2 (relay K2)

Supply

Supply voltage	85 102 436 / 85 103 436 : 24 V AC/DC 85 102 434 : 110-115 VAC 85 102 435 : 230 VAC
Supply frequency range (Hz)	50 / 60
Operating range	AC/DC : $\pm 10\%$ Un AC : -15% $+10\%$ Un
Consumption	1,5 W (24 VDC) 3,7 VA (230 VAC)
Initialization time	250 ms

Precision

Maximum reset time	30 ms (manual start) 350 ms (automatic start)
Maximum response time on emergency stop	150 ms (AC/DC) 50 ms (AC)

Output specification

Type	Forcibly guided relays (positively driven)
Number of safety circuits	3 NO
Number of data circuits	1 NC
Nominal output voltage	250 V AC max.
Max. thermal current I for each contact	8 A
Maximum power rating	According to AC15 (NO contacts) : 3 A / 230 V AC According to AC15 (NC contacts) : 2 A / 230 VAC According to DC13 (NO contacts) : 4 A / 24 VDC ; 0,5 A / 110 VDC According to DC13 (NC contacts) : 4 A / 24 VDC
Electrical endurance	At 5 A, 230 VAC, $\cos \varphi = 1$: $1,5 \times 10^5$ switching cycles At 8 A, 24 VDC, according to DC 13 (NO contacts) : 25×10^3 switching cycles (ON : 0,4 s ; OFF : 9,6 s)
Mechanical life	20×10^6 switching cycles
Maximum rate	1200 switching cycles / h
Protection against short circuits	Max. fuse rating : 10 A gL Line circuit breaker : B 6 A

Climatic environment

Operating temperature (°C)	-15 → +55
Storage temperature (°C)	-25 → +85
Altitude	< 2000 m
Climate resistance according to IEC/EN 60068-1	15 / 055 / 04

Mechanical environment

Vibration resistance according to IEC/EN 60068-2-6	Amplitude : 0,35 mm Frequency : 10 →55 Hz
--	--

Electromagnetic environment

Immunity to electrostatic discharges acc. IEC/EN 61000-4-2	8 kV (air)
Immunity to radiated, radio-frequency, electromagnetic field acc. IEC/EN 61000-4-3	10 V / m
Immunity to rapid transient bursts acc. to IEC/EN 61000-4-4	2 kV
Immunity to shock waves according to IEC/EN 61000-4-5	Between wires for power supply : 1 kV (AC), 0,5 kV (24 V AC/DC) Between wires and ground : 2 kV
Immunity to radio frequency in common mode acc. to IEC/EN 61000-4-6	10 V
Interference suppression according to IEC/EN 55011	Limit value class B

Housing

Material : self-extinguishing (UL94VO)	Thermoplastic with V0 extinction behaviour
Protection (IEC/EN 60529) - Casing	IP40
Protection (IEC/EN 60529) - Term. block	IP20
Mounting	DIN-rail
Weight (g)	210 (24 VAC/DC) 275 (230 VAC)

Safety standards

Approvals	CE, TÜV, UL / CSA
Environmental directive 2002/95/CE	RoHS
Environmental regulation 1907/2006	Reach
Security data according to EN ISO 13849-1	Performance Level (PL) : e Category : 4
SIL Claimed Level (SIL CL) to IEC/EN 62061	3
Safety Integrity Level (SIL) according to CEI/EN 61508	3
Safety category to EN 954-1	4

Principles

EN ISO 13849-1:		
Category:	4	
PL:	e	
MTTF _d :	> 100	a (year)
DC _{avg} :	99,0	%
d _{op} :	365	d/a (days/year)
h _{op} :	24	h/d (hours/day)
t _{cycle} :	3600	s/cycle
	≅ 1	/h (hour)

IEC/EN 62061 IEC/EN 61508:		
SIL CL:	3	IEC/EN 62061
SIL	3	IEC/EN 61508
HFT ^{*)} :	1	
DC _{avg} :	99,0	%
SFF	99,7	%
PFH _D :	2,66E-10	h ⁻¹
*) HFT = Hardware failure tolerance		

Dimensions (mm)



Dimensions (mm)

KNE3-YS - Screw terminals

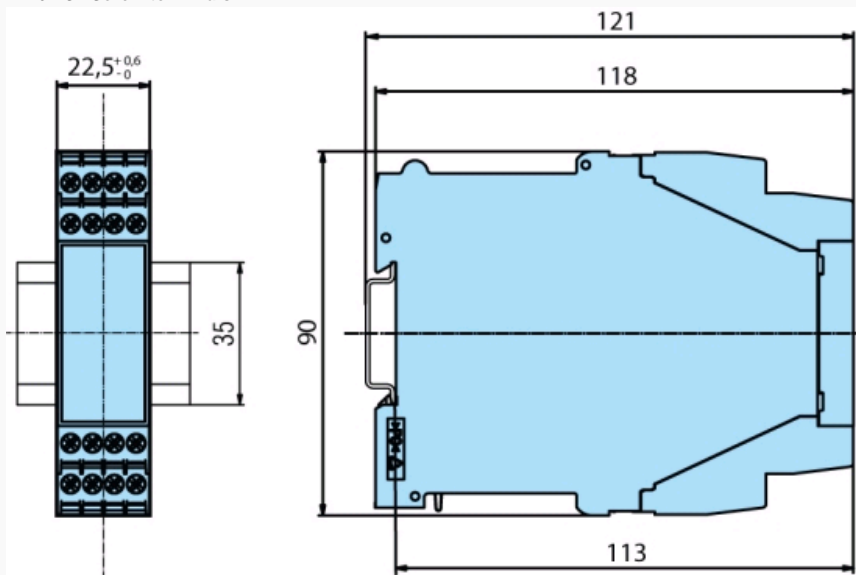

Curves

Function diagram

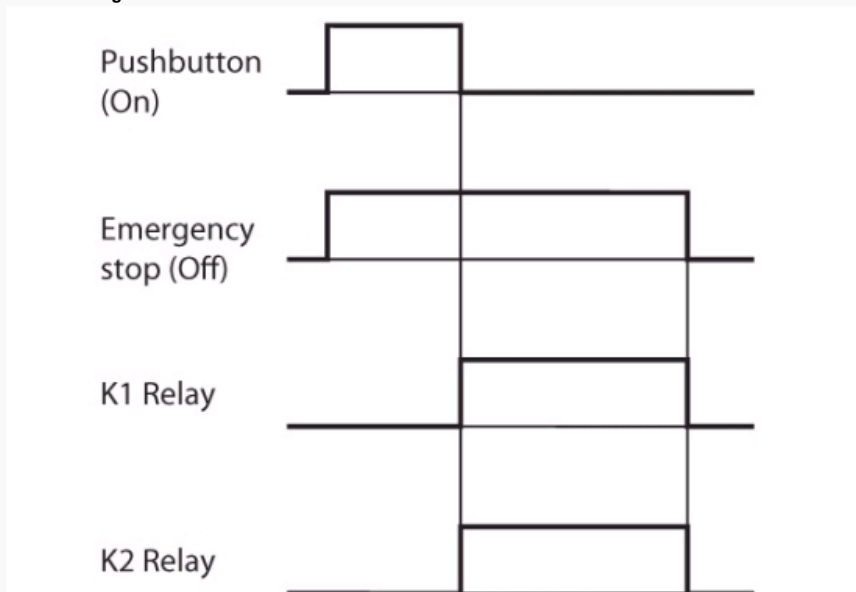

Connections

Front face drawing KNE3-YS

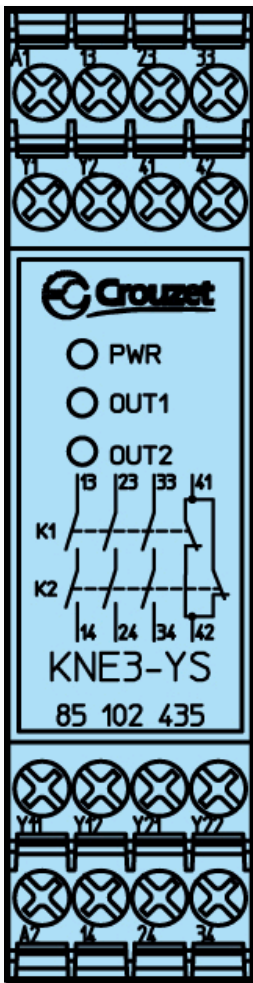

Connections

Contacts

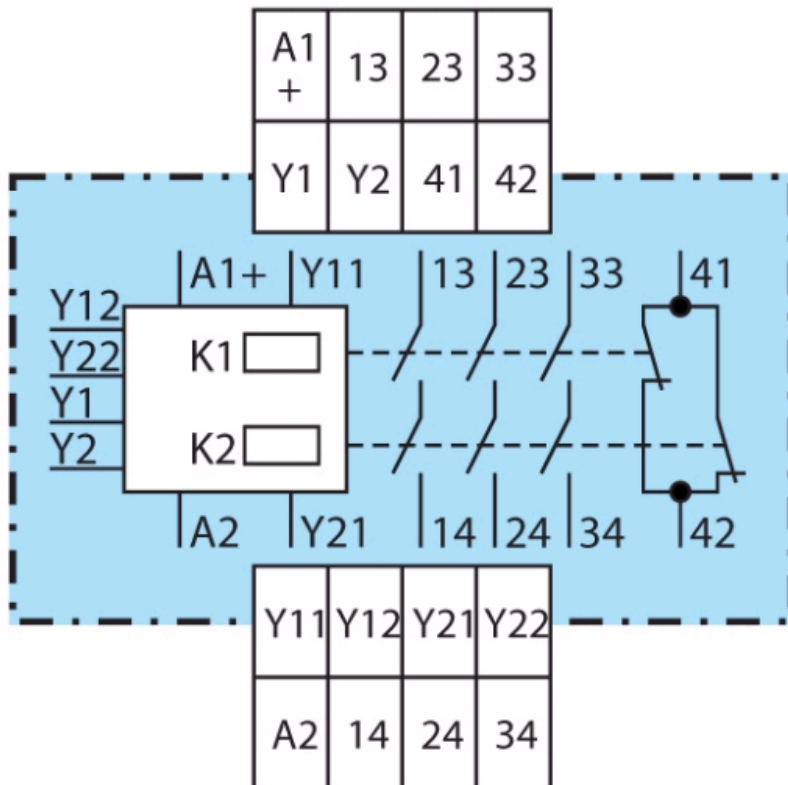

A1 (+) : + / L A2 : - / N Y1, Y2 : Validation Input Y11, Y21, Y12, Y22 : Control Inputs 13, 14, 23, 24, 33, 34 : Safety circuit outputs (forcibly guided NO contacts) 41, 42 : Monitoring output (forcibly

Applications

Single channel emergency stop circuit

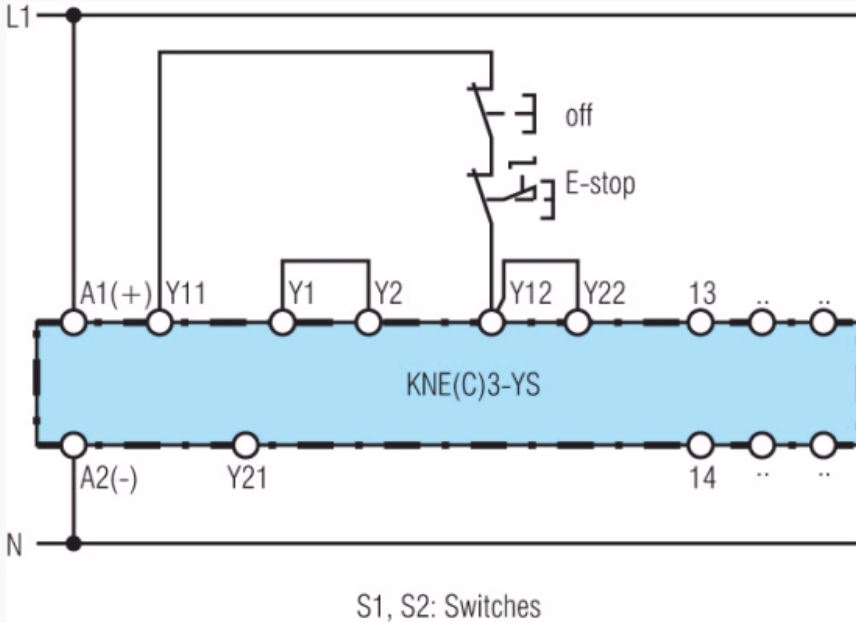

This circuit does not have any redundancy in the emergency-stop control circuit. S1 : no cross fault detection S2 : automatic start

Applications

2-channel emergency stop circuit without cross fault monitoring

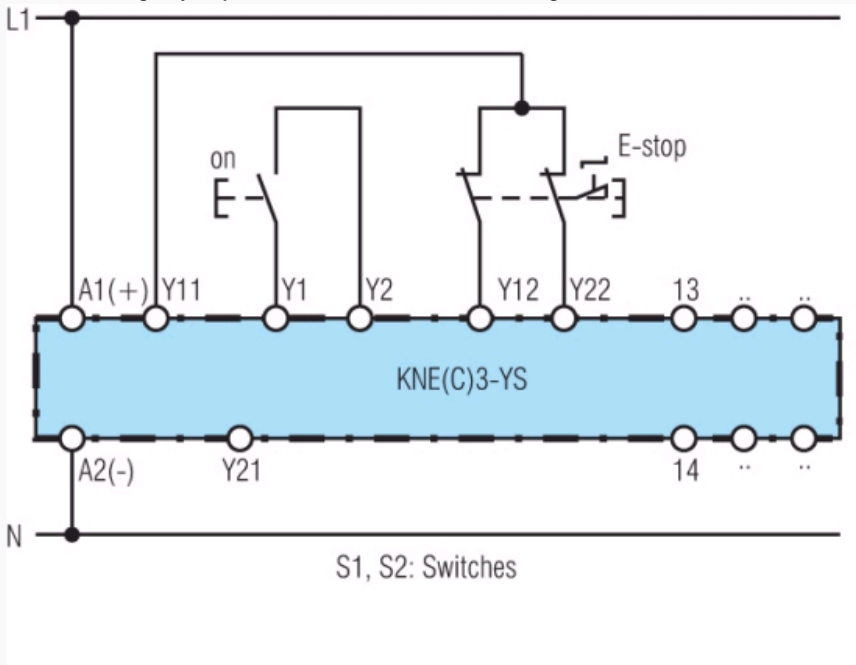

S1 : no cross fault detection S2 : manual start

Applications

Contact reinforcement by external contactors controlled by one contact path

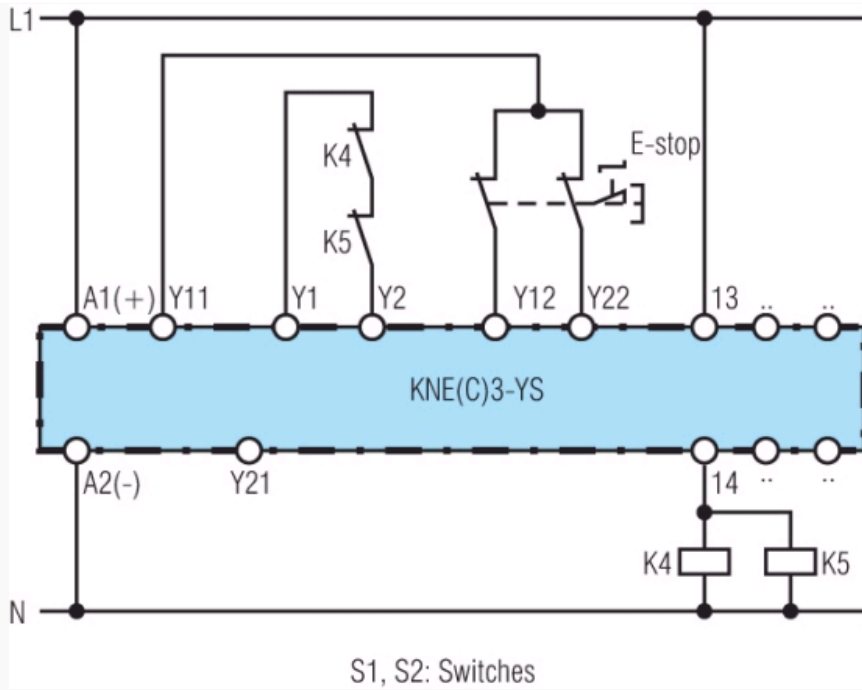

S1 : no cross fault detection S2 : automatic start

Applications
2-channel safety gate monitoring

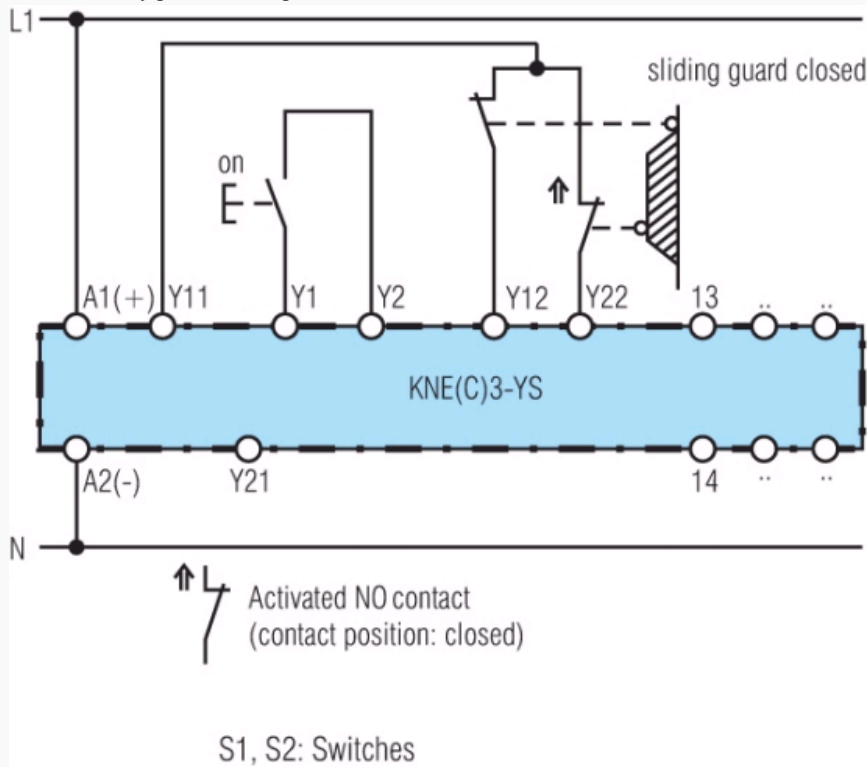

S1 : no cross fault detection S2 : manual start

Applications
Contact reinforcement by external contactors, 2-channel controlled

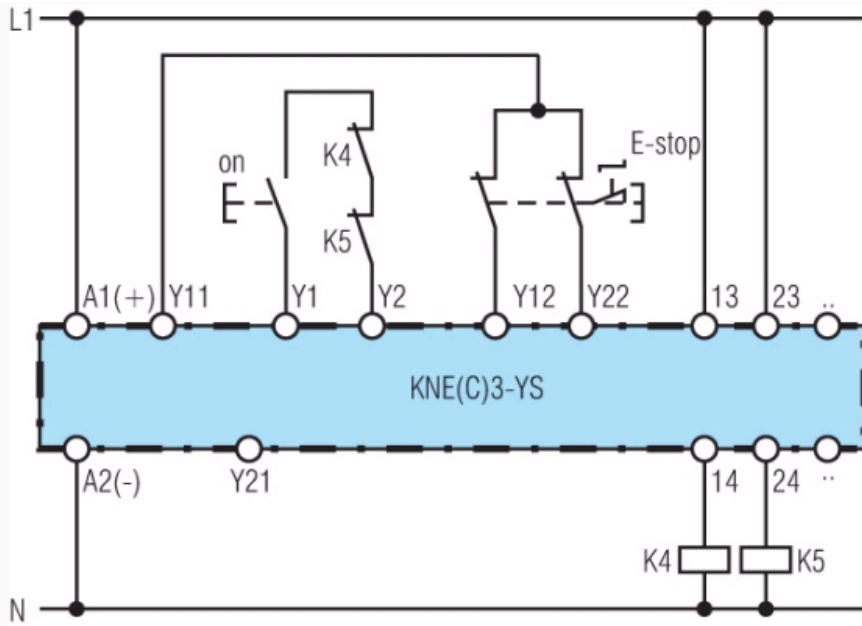

S1, S2: Switches

For currents > 8 A, the output contacts can be reinforced by external contactors. Functioning of the external contactors is monitored by looping the NC contacts into the start circuit (Y1-Y2)

Applications

2-channel emergency stop circuit with cross fault monitoring

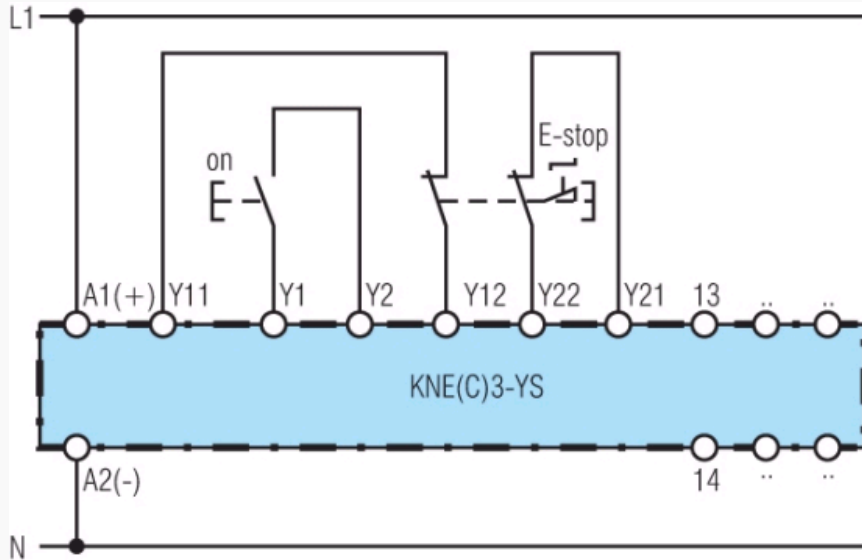

S1, S2: Switches

S1 : cross fault detection S2 : manual start



Компания «ЭлектроПласт» предлагает заключение долгосрочных отношений при поставках импортных электронных компонентов на взаимовыгодных условиях!

Наши преимущества:

- Оперативные поставки широкого спектра электронных компонентов отечественного и импортного производства напрямую от производителей и с крупнейших мировых складов;
- Поставка более 17-ти миллионов наименований электронных компонентов;
- Поставка сложных, дефицитных, либо снятых с производства позиций;
- Оперативные сроки поставки под заказ (от 5 рабочих дней);
- Экспресс доставка в любую точку России;
- Техническая поддержка проекта, помощь в подборе аналогов, поставка прототипов;
- Система менеджмента качества сертифицирована по Международному стандарту ISO 9001;
- Лицензия ФСБ на осуществление работ с использованием сведений, составляющих государственную тайну;
- Поставка специализированных компонентов (Xilinx, Altera, Analog Devices, Intersil, Interpoint, Microsemi, Aeroflex, Peregrine, Syfer, Eurofarad, Texas Instrument, Miteq, Cobham, E2V, MA-COM, Hittite, Mini-Circuits, General Dynamics и др.);

Помимо этого, одним из направлений компании «ЭлектроПласт» является направление «Источники питания». Мы предлагаем Вам помощь Конструкторского отдела:

- Подбор оптимального решения, техническое обоснование при выборе компонента;
- Подбор аналогов;
- Консультации по применению компонента;
- Поставка образцов и прототипов;
- Техническая поддержка проекта;
- Защита от снятия компонента с производства.



Как с нами связаться

Телефон: 8 (812) 309 58 32 (многоканальный)

Факс: 8 (812) 320-02-42

Электронная почта: org@eplast1.ru

Адрес: 198099, г. Санкт-Петербург, ул. Калинина, дом 2, корпус 4, литера А.