

PRODUCT NUMBER

55003-X 01 ZZZ LF

"LEAD FREE" (OPTIONAL)
 SPECIAL LOAD PATTERN
 SEE SHEET 4
 SIZE (1 MOD)
 PLATING PERFORMANCE
 LEVEL, SEE SHEET 2
 BASE NUMBER

MATING LENGTH
 DIM A ±0.20
 SEE NOTE 12

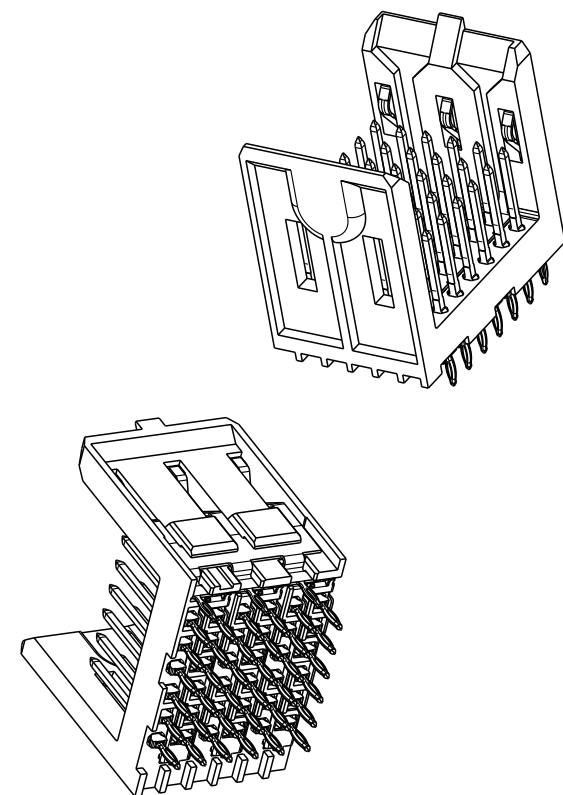
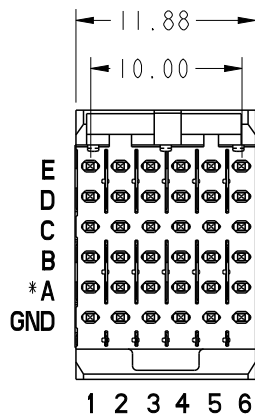
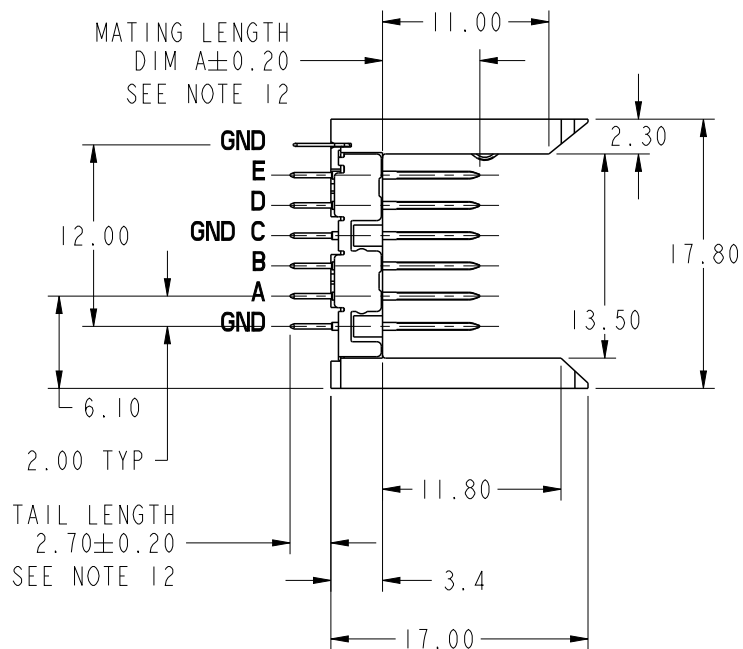

***ROW C INFORMATION**
 ODD NUMBER COLUMNS WITHIN ROW C ARE COMMONED TO GROUND INTERNALLY WITHIN THE HOUSING. THE EVEN NUMBER COLUMNS WITHIN ROW C ARE NOT. FOR MAXIMUM PERFORMANCE IT IS RECOMMENDED THESE EVEN COLUMNS BE GROUND COMMONED WITHIN PCB. SEE NOTE 11

spec ref -		dr P-Mathew Nebu 2011/05/19		projection 	mm 	size A4	scale 2:1
tolerance std ISO 406 ISO 1101		eng Stalin Alosius 2014/07/24				ecn no ELX-I-17886-1	
TOLERANCES UNLESS OTHERWISE SPECIFIED		chr -				rel level Released	
surface		appr K-Paul Biju 2014/07/24		product family METRAL 4000		rev	
linear		0.X ±0.3		title VERTICAL SIGNAL HDR 5 ROW P.F. 30 POS. SPECIAL LOAD STD.		dwg no 55003	
angular		0° ±2°					
0.XX ±0.13		cat. no.					
0.XXX ±0.051		www.fci.com		PDS: Rev :M		STATUS:Released	



Copyright FCI.

PRODUCT NUMBER	PLATING PERFORMANCE LEVEL
55003-101ZZZ	TELCORDIA CO
55003-101ZZZLF	TELCORDIA CO
55003-501ZZZ	TELCORDIA UE
55003-501ZZZLF	TELCORDIA UE
55003-901ZZZ	TELCORDIA CO
55003-901ZZZLF	TELCORDIA CO

NOTES:

- SEE APPLICATION SPECIFICATION GS-20-014 FOR INFORMATION ON AVAILABLE TOOLING, CIRCUIT BOARD DESIGN CONSIDERATIONS, REPAIR PROCEDURES AND PRODUCT OFFERINGS. SEE PRODUCT SPECIFICATION GS-12-184.
- UNLESS OTHERWISE SPECIFIED, ALL DIMENSIONS AND TOLERANCES ARE IN ACCORDANCE WITH ASME Y14.5, 1994
- HOUSING MATERIAL: LIQUID CRYSTAL POLYMER, 30% GLASS FILLED, FLAME RETARDANT PER UL 94-V0.
PIN MATERIAL: PHOSPHOR BRONZE
GROUND SPRING MATERIAL: PHOSPHOR BRONZE
STRIPLINE SHIELD MATERIAL: PHOSPHOR BRONZE
- DIMENSIONAL RESTRICTIONS OF PINS IN HEADERS.
FOR USE WITH METRAL 4000 RECEPTACLES.
DIM A : 5.00mm MIN, 6.50mm MAX FOR ROWS A,B,D,E
DIM A : 5.00mm MIN, 8.00mm MAX FOR ROWS C
DIM A : 5.00mm MIN, 5.75mm MAX FOR ROWS GND
FOR USE WITH METRAL 1000 RECEPTACLES
DIM A : 5.00mm MIN, 8.00mm MAX FOR ROWS A,B,C,D,E
DIM A : 5.00mm MIN, 5.75mm MAX FOR ROW GND
- THE MIN PCB THICKNESS FOR FRONT PLUG-UP APPLICATIONS IS 1.6mm.
- THE 'CONNECTOR OUTLINE' IS THE MIN OUTLINE REQUIRED. TO DETERMINE THE OUTLINE NECESSARY TO PERMIT THE VARIOUS TYPES OF REPAIR OPERATIONS, SEE APPLICATION SPECIFICATION GS-20-010.
- CURRENT RATING : 1 AMP PER PIN
- TEMPERATURE RANGE : -55°C TO +105°C
- P/N 55003-X01ZZZ SHOWN.
- AVOID TRACES ON TOP OF BOARD DUE TO EXPOSED GROUND SHIELD.
- FOR FRONT PLUG-UP APPLICATIONS, THE EVEN NUMBERED PINS IN ROW "C" CAN BE USED FOR POWER AS WELL AS FOR GROUND. IF THE SURROUNDING PINS ARE NOT USED FOR POWER, THEN EACH PIN CAN CARRY 3 AMPS. IF THE SURROUNDING PINS ARE USED FOR POWER, THEN EACH PIN CAN CARRY 1 AMP. WHEN THE SURROUNDING PINS ARE USED ONLY FOR LOW SPEED SIGNALS, THEN THE EVEN NUMBERED "C" ROW PINS CAN ALSO BE USED FOR LOW SPEED SIGNALS.
- AFTER INSERTION INTO, CIRCUIT BOARD WITH QUALIFIED TOOL.
- PRODUCTS WHERE THE PART NUMBER ENDS IN 'LF' MEET EUROPEAN UNION DIRECTIVES AND OTHER COUNTRY REGULATIONS AS DESCRIBED IN GS-22-008.
ALL PRODUCTS WILL WITHSTAND EXPOSURE TO 260°C FOR 60 SECONDS IN A CONVECTION, INFRA-RED OR VAPOR PHASE REFLOW OVEN.
- FOR LEAD FREE PART NUMBERS, ADD AN 'LF' SUFFIX.
EXAMPLE: 55003-X01002LF.
- PLATING INFORMATION: PLATING ON CONTACT AREA MEETS THE PERFORMANCE LEVELS SHOWN IN TABLE ON THIS SHEET. PLATING ON "LF" TAILS IN Sn. PLATING ON ALL OTHER TAILS IS SnPb.
EQUIVALENT PRECIOUS METAL PLATING MAY BE SUBSTITUTED.

spec ref	-	dr	P-Mathew Nebu	2011/05/19	projection	mm	size	A4	scale	2:1		
tolerance std	TOLERANCES UNLESS OTHERWISE SPECIFIED	eng	Stalin Alosius	2014/07/24			ecn no	ELX-I-17886-1				
ISO 406		chr	-	-				rel level	Released			
ISO 1101		appr	K-Paul Biju	2014/07/24	product family	METRAL 4000						
surface	linear	0.X	±0.3		title	VERTICAL SIGNAL HDR 5 ROW	dwg no	55003			rev	M
ISO 1302		0.XX	±0.13					www.fci.com	cat. no.	Product - Customer Drw		
	angular	0°	±2°	sheet 2 of 4								

PRODUCT NUMBER
SEE SHEETS 1, 2, 4

PRESS-FIT HOLES	OPTION 1 SnPb PLATING	OPTION 2 Sn PLATING	OPTION 3 COPPER	OPTION 4 IMMERSION Ag
FINISHED HOLE DIAMETER	0.45-0.55	0.46-0.55	0.48-0.57	0.48-0.57
DRILLED HOLE SIZE	0.60±0.02	0.60±0.02	0.60±0.02	0.60±0.02
COPPER PLATING THICKNESS	0.025 MIN-0.050 MAX.	0.025 MIN-0.050 MAX.	0.025 MIN-0.050 MAX.	0.025 MIN-0.050 MAX.
HOLE PLATING	0.005-0.015 SnPb	0.0008-0.0012 Sn	NONE	.0002 - .0006 Ag

RECOMMENDED PCB HOLE PATTERN
(COMPONENT SIDE) SEE NOTE 10

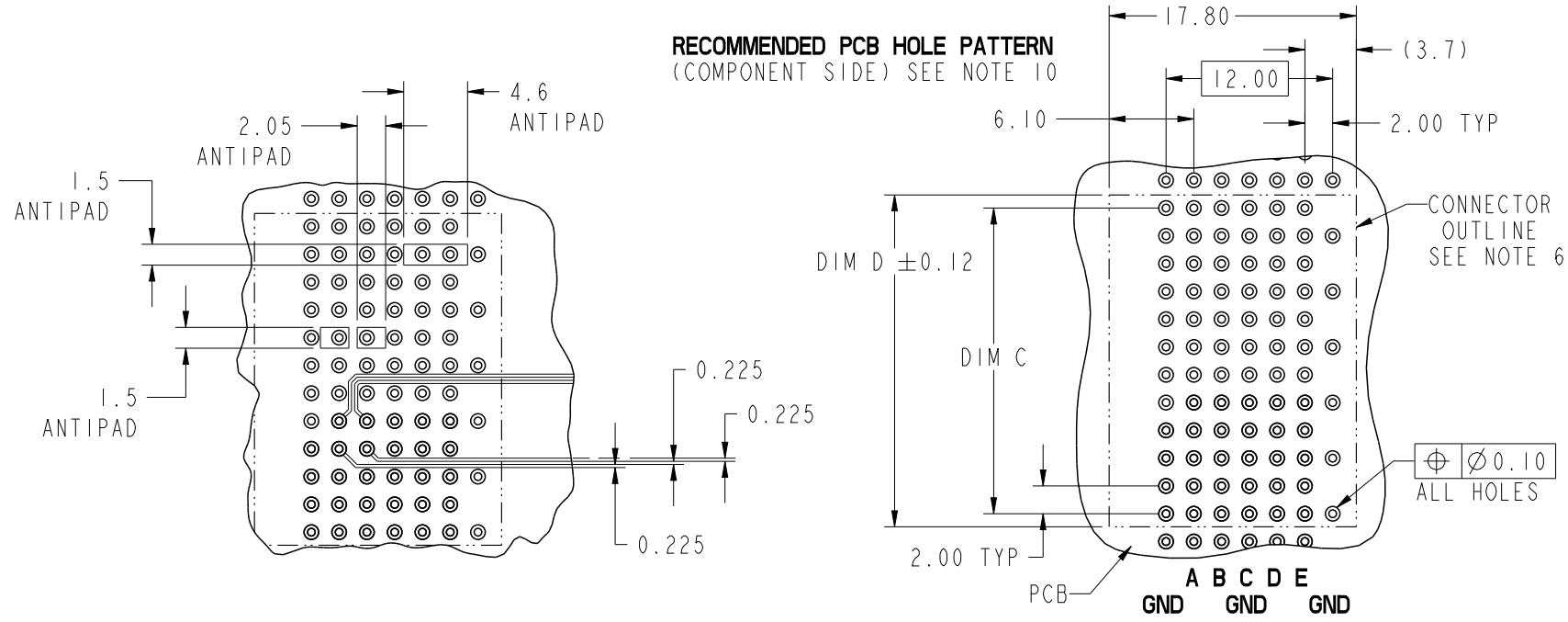

RECOMMENDED TRACK AND ANTIPAD DIMENSIONS
SCALE 2:1

spec ref	-	dr	P-Mathew Nebu	2011/05/19	projection	mm	size	A4	scale	1:1	
tolerance std	ISO 406 ISO 1101	eng	Stalin Alosius	2014/07/24		←→	ecn no	ELX-I-17886-1			
TOLERANCES UNLESS OTHERWISE SPECIFIED		chr	-	-				rel level	Released		
surface	ISO 1302	appr	K-Paul Biju	2014/07/24	product family	METRAL 4000		rev			
linear	0.X	±0.3		title	VERTICAL SIGNAL HDR 5 ROW			dwg no	55003		M
	0.XX	±0.13			P.F. 30 POS. SPECIAL LOAD STD.						
	0.XXX	±0.051			cat. no.	Product - Customer Drw			sheet 3 of 4		
angular	0°	±2°	www.fci.com		Product - Customer Drw						

ProjE File - REV C - 2009-06-09



Copyright FCI.

SPECIAL LOAD PATTERNS

PRODUCT #	ROW	PIN CODES
55003-X01002 SEE NOTE 14 LEAD FREE OPTION	E	03
	D	
	C	
	B	
	A	
	GND	02

PRODUCT #	ROW	PIN CODES
55003-X01005 SEE NOTE 14 LEAD FREE OPTION	E	01
	D	
	C	
	B	
	A	
	GND	

DIM A	PIN CODES
5.00	01
5.75	02
6.50	03
7.25	04
8.00	*19

* CURRENTLY NOT AVAILABLE

PRODUCT #	ROW	PIN CODES
55003-X01003 SEE NOTE 14 LEAD FREE OPTION	E	02
	D	
	C	
	B	
	A	
	GND	

PRODUCT #	ROW	PIN CODES
55003-X01004 SEE NOTE 14 LEAD FREE OPTION	E	02
	D	
	C	
	B	
	A	
	GND	NONE

spec ref -		dr P-Mathew Nebu	2011/05/19	projection 	mm 	size A4	scale 1:1
tolerance std ISO 406 ISO 1101	TOLERANCES UNLESS OTHERWISE SPECIFIED		eng Stalin Alosius			2014/07/24	ecn no ELX-I-17886-1
			chr -			-	rel level Released
surface <input checked="" type="checkbox"/> ISO 1302	linear	0.X	±0.3	product family METRAL 4000	title VERTICAL SIGNAL HDR 5 ROW P.F. 30 POS. SPECIAL LOAD STD.	dwg no 55003	rev M
		0.XX	±0.13				
		0.XXX	±0.051				
	angular	0°	±2°	www.fci.com	cat. no.	Product - Customer Drw	sheet 4 of 4



Copyright FCI.



Компания «ЭлектроПласт» предлагает заключение долгосрочных отношений при поставках импортных электронных компонентов на взаимовыгодных условиях!

Наши преимущества:

- Оперативные поставки широкого спектра электронных компонентов отечественного и импортного производства напрямую от производителей и с крупнейших мировых складов;
- Поставка более 17-ти миллионов наименований электронных компонентов;
- Поставка сложных, дефицитных, либо снятых с производства позиций;
- Оперативные сроки поставки под заказ (от 5 рабочих дней);
- Экспресс доставка в любую точку России;
- Техническая поддержка проекта, помощь в подборе аналогов, поставка прототипов;
- Система менеджмента качества сертифицирована по Международному стандарту ISO 9001;
- Лицензия ФСБ на осуществление работ с использованием сведений, составляющих государственную тайну;
- Поставка специализированных компонентов (Xilinx, Altera, Analog Devices, Intersil, Interpoint, Microsemi, Aeroflex, Peregrine, Syfer, Eurofarad, Texas Instrument, Miteq, Cobham, E2V, MA-COM, Hittite, Mini-Circuits, General Dynamics и др.);

Помимо этого, одним из направлений компании «ЭлектроПласт» является направление «Источники питания». Мы предлагаем Вам помощь Конструкторского отдела:

- Подбор оптимального решения, техническое обоснование при выборе компонента;
- Подбор аналогов;
- Консультации по применению компонента;
- Поставка образцов и прототипов;
- Техническая поддержка проекта;
- Защита от снятия компонента с производства.



Как с нами связаться

Телефон: 8 (812) 309 58 32 (многоканальный)

Факс: 8 (812) 320-02-42

Электронная почта: org@eplast1.ru

Адрес: 198099, г. Санкт-Петербург, ул. Калинина, дом 2, корпус 4, литера А.