

## Product Brief

# KP21x/MAP

## Integrated Pressure Sensor IC for Manifold Air Pressure Measurement Applications

The manifold air pressure (MAP) is an important parameter to compute the airfuel ratio provided to the engine for lower emission due to better combustion and increased efficiency. For cost sensitive engine systems a MAP sensor shows the potential to complement or even substitute mass air flow (MAF) sensors. In addition manifold pressure data can be used to compute diagnostics of leakages and malfunctions of the exhaust gas recirculation valve. In automotive applications where high production volumes are common there is substantial interest in precision, low-cost and fully integrated sensors. In this context products of the developed MAP sensor family KP21x are the optimum solution for aspirated or turbo diesel and gasoline engines management systems.

### Features

- Absolute air pressure measurement
- Excellent accuracy of up to 1.0kPa over a large temperature range
- Ratiometric analog output
- Output signal fully compensated
- Pressure range from 15 to 150kPa
- Temperature range (ambient) from -40 to +140°C
- SMD package (PG-DSOF-8-16)
- Output clamping (optional for KP216)
- Complete product family (KP214, KP215, KP216)

### Typical Application

- Engine control/MAP applications
- Industrial controls

### Application Circuit for the Pressure Sensor System

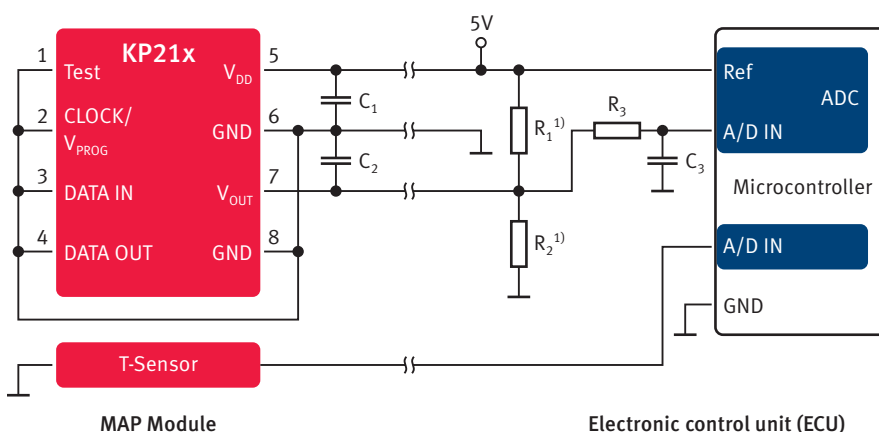

1)  $R_1$  and  $R_2$  only alternatively



# KP21x/MAP

## Integrated Pressure Sensor IC for Manifold Air Pressure Measurement Applications

### Highly Integrated Sensors - Single Chip

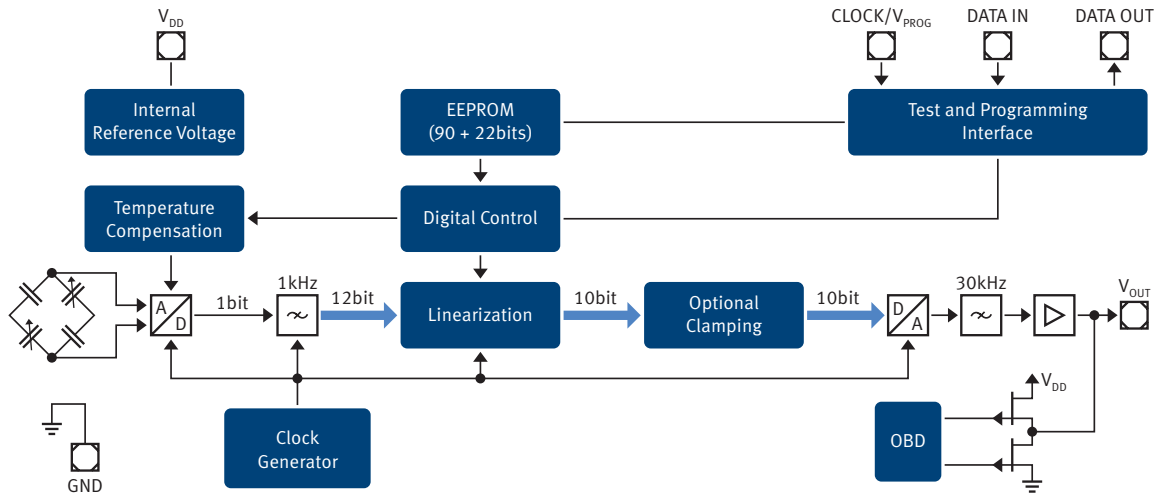

Infineon offers an extensive broad product portfolio for diesel engine management systems from micro-machined sensors to smart power ICs and microcontrollers. The KP21x pressure sensor as an integrated pressure sensor for manifold pressure measurement is a benchmark in terms of reliability, performance and integration level.

### Product Summary

Parameter	Range			Unit
	min.	typ.	max.	
Accuracy			1.0	% F.S.
Pressure range	10		150	kPa
Sensitivity	40		88	mV/kPa
Supply voltage	4.5	5.0	5.5	V
Output current			1.0	mA
Output voltage	0.1		4.85	V
Operating temperature	-40		+140	°C
<b>Programmable Transfer Functions</b>				
Transfer function pressure min.	15		60	kPa
Transfer function pressure max.	100		150	kPa
Transfer function voltage min.	0.1		0.5	V
Transfer function voltage max.	4.5		4.85	V
Lower programmable clamping level (KP226)	0.0		0.63	V
Upper programmable clamping level (KP226)	4.37		5.0	V

Published by  
Infineon Technologies AG  
85579 Neubiberg, Germany

© 2013 Infineon Technologies AG.  
All Rights Reserved.

Visit us:  
[www.infineon.com](http://www.infineon.com)

Order Number: B142-H9193-G1-X-7600  
Date: 08 / 2013

#### Attention please!

The information given in this document shall in no event be regarded as a guarantee of conditions or characteristics ("Beschaffenheitsgarantie"). With respect to any examples or hints given herein, any typical values stated herein and/or any information regarding the application of the device, Infineon Technologies hereby disclaims any and all warranties and liabilities of any kind, including without limitation warranties of non-infringement of intellectual property rights of any third party.

#### Information

For further information on technology, delivery terms and conditions and prices please contact your nearest Infineon Technologies Office ([www.infineon.com](http://www.infineon.com)).

#### Warnings

Due to technical requirements components may contain dangerous substances. For information on the types in question please contact your nearest Infineon Technologies Office. Infineon Technologies Components may only be used in life-support devices or systems with the express written approval of Infineon Technologies, if a failure of such components can reasonably be expected to cause the failure of that life-support device or system, or to affect the safety or effectiveness of that device or system. Life support devices or systems are intended to be implanted in the human body, or to support and/or maintain and sustain and/or protect human life. If they fail, it is reasonable to assume that the health of the user or other persons may be endangered.



Компания «ЭлектроПласт» предлагает заключение долгосрочных отношений при поставках импортных электронных компонентов на взаимовыгодных условиях!

Наши преимущества:

- Оперативные поставки широкого спектра электронных компонентов отечественного и импортного производства напрямую от производителей и с крупнейших мировых складов;
- Поставка более 17-ти миллионов наименований электронных компонентов;
- Поставка сложных, дефицитных, либо снятых с производства позиций;
- Оперативные сроки поставки под заказ (от 5 рабочих дней);
- Экспресс доставка в любую точку России;
- Техническая поддержка проекта, помощь в подборе аналогов, поставка прототипов;
- Система менеджмента качества сертифицирована по Международному стандарту ISO 9001;
- Лицензия ФСБ на осуществление работ с использованием сведений, составляющих государственную тайну;
- Поставка специализированных компонентов (Xilinx, Altera, Analog Devices, Intersil, Interpoint, Microsemi, Aeroflex, Peregrine, Syfer, Eurofarad, Texas Instrument, Miteq, Cobham, E2V, MA-COM, Hittite, Mini-Circuits, General Dynamics и др.);

Помимо этого, одним из направлений компании «ЭлектроПласт» является направление «Источники питания». Мы предлагаем Вам помощь Конструкторского отдела:

- Подбор оптимального решения, техническое обоснование при выборе компонента;
- Подбор аналогов;
- Консультации по применению компонента;
- Поставка образцов и прототипов;
- Техническая поддержка проекта;
- Защита от снятия компонента с производства.



#### Как с нами связаться

**Телефон:** 8 (812) 309 58 32 (многоканальный)

**Факс:** 8 (812) 320-02-42

**Электронная почта:** [org@eplast1.ru](mailto:org@eplast1.ru)

**Адрес:** 198099, г. Санкт-Петербург, ул. Калинина, дом 2, корпус 4, литера А.