

Optimum Cooling with a Comprehensive Lineup of Axial Fans

- Low noise level, long service life, and resistance to the environment.
- Shaft supported by ball bearings for highly-reliable operation.
- Plastic-bladed models (44 type) and metal-bladed models (28 type) included in series.
- R87T-A□A15H-WR Water-resistant AC Axial Fans (IP X7 degree of protection) added to series.
- CE marking compliant and certified by UL and CSA.

Note: The compliant standards and certified safety standards depend on the product. Check the information given for available models of Axial fans and the information in *Characteristics*.



 Be sure to read the *Safety Precautions for All Axial Fans*.

Model Number Structure

Model Number Legend

R87 - -

1 2 3 4 5 6 7 8

1. Basic series

R87F: Plastic blade
R87T: Metal blade

2. Rated voltage

A1: 100 VAC
A3: 115 VAC
A4: 200 VAC
A6: 230 VAC

3. Frame material

A: Die-cast

4. Frame size

0: 150 dia.
1: 120 × 120
9: 92 × 92
8: 80 × 80

5. Frame thickness

3: 25
5: 38
7: 55

6. Rotational speed

H: High
M: Medium
L: Low

7. Terminal type

No marking: Lead wires
P: Terminals (See note 1.)

8. Type

No marking: Standard
WR: Water-resistant

Note: 1. A Plug Cord (R87F-PC) is available as an option for models with terminals.

2. These tables show only how to read product markings. They do not indicate which products are available. Refer to “*Ratings and Ordering Information*” when ordering.

Ordering Information

Available Models

AC Axial Fans

Series	Size (mm)	Model	Datasheet available
R87F (plastic blades)	120 × 120 × t38	R87F-A□A15	Refer to page 2.
	120 × 120 × t25	R87F-A□A13	Refer to page 4.
	92 × 92 × t25	R87F-A□A93	Refer to page 6.
	80 × 80 × t38	R87F-A□A85	Refer to page 8.
	80 × 80 × t25	R87F-A□A83	Refer to page 10.
R87T (metal blades)	120 × 120 × t38	R87T-A□A15H-WR	Refer to page 12.
	150-dia. × t55	R87T-A□A07	Refer to page 14.
	150-dia. × t38	R87T-A□A05	Refer to page 16.
	120 × 120 × t38	R87T-A□A15	Refer to page 18.
	80 × 80 × t38	R87T-A□A85	Refer to page 20.
	80 × 80 × t25	R87T-A□A83	Refer to page 22.

Options

Product name	Model	Datasheet available
Plug Cord	R87F-PC	Refer to page 24.
Finger Guard	R87F-FG□	Refer to page 25.
Filter	R87F-FL□(S)	Refer to page 26.

Note: Mounting screws are not provided.

Safety Precautions

Refer to the “*Safety Precautions for All Axial Fans*”.

AC Axial Fans with Terminals (120 × 120 × t38 mm)

R87F-A□A15

Specifications

Ratings and Ordering Information

Note: An asterisk (*) indicates a nominal value.

Item Model	Rated voltage (V)	Permitted voltage fluctuation range (%)	Frequency (Hz)	Rated current (A) *		Rated input (W) *		Rated rotational speed (r/min) *		Maximum flow rate (m ³ /min) *		Maximum static pressure (Pa) *		Noise (dB) *	
				50 Hz	60 Hz	50 Hz	60 Hz	50 Hz	60 Hz	50 Hz	60 Hz	50 Hz	60 Hz	50 Hz	60 Hz
R87F-A1A15HP	100	85% to 110% rated voltage	50/60	0.230	0.220	15	14	2,750	3,200	2.7	3.1	93.1	99.0	42	46
R87F-A3A15HP	115			0.200	0.180										
R87F-A4A15HP	200			0.110	0.100										
R87F-A6A15HP	230			0.100	0.085										
R87F-A1A15MP	100	85% to 110% rated voltage	50/60	0.210	0.180	15	14	2,450	2,700	2.2	2.5	63.7	63.7	39	42
R87F-A3A15MP	115			0.190	0.160										
R87F-A4A15MP	200			0.100	0.090										
R87F-A6A15MP	230			0.085	0.075										
R87F-A1A15LP	100	85% to 110% rated voltage	50/60	0.170	0.150	11	10	2,100	2,250	2.0	2.1	44.1	44.1	36	38
R87F-A3A15LP	115			0.150	0.130										
R87F-A4A15LP	200			0.080	0.070										
R87F-A6A15LP	230			0.072	0.064										

Characteristics

Motor type	Single-phase shading coil induction motor (2-pole, open type)
Terminal type	Terminals
Insulation class	IEC class B (130°C) UL class A (105°C) CSA class A (105°C)
Insulation resistance	100 MΩ min. (at 500 VDC) between all power supply connections and uncharged metal parts.
Insulation withstand voltage	2,000 VAC (1 minute) between all power supply connections and uncharged metal parts.
Ambient operating temperature	-30 to 70°C (no icing)
Ambient storage temperature	-40 to 85°C (no icing)
Ambient humidity	25% to 85%
Protection	Impedance protection
Materials	Frame: Die-cast aluminum Blades: Glass polycarbonate
Bearings	Ball bearings
Weight	Approx. 540 g
Compliant standards	PSE, EN/IEC 60335 (CE marking compliant)
Certified standards	UL/CSA

Flow Rate and Static Pressure Characteristics (Reference Values)

R87F-A□A15HP

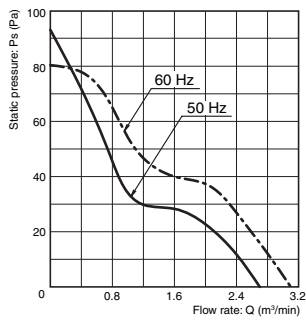

R87F-A□A15MP

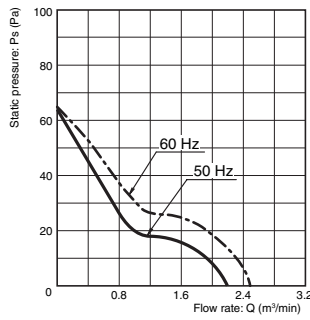

R87F-A□A15LP

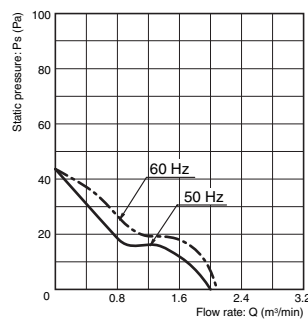

Note: For details on measurement conditions, refer to *Flow Rate and Static Pressure on Safety Precautions for All Axial Fans*.

Dimensions

(Unit: mm)

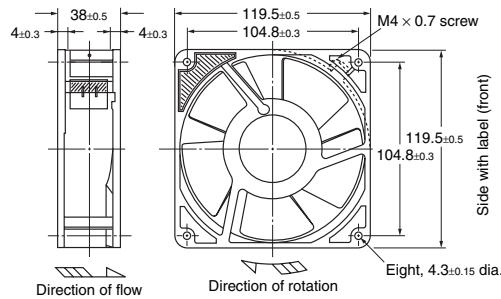

Screw hole for grounding



M4 screw: 0.7 pitch

Terminal shape



Faston #110 terminals (or equivalent)

Panel Cutouts

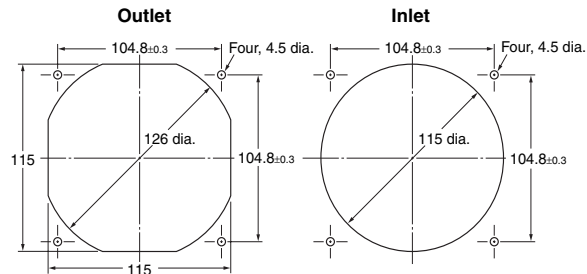

Options

Name	Model	Datasheet available
Plug Cord	R87F-PC	Refer to page 24.
Finger Guard	R87F-FG120	Refer to page 25.
Filter	R87F-FL120(S)	Refer to page 26.

ALL DIMENSIONS SHOWN ARE IN MILLIMETERS.

To convert millimeters into inches, multiply by 0.03937. To convert grams into ounces, multiply by 0.03527.

In the interest of product improvement, specifications are subject to change without notice.

AC Axial Fans with Terminals (120 × 120 × t25 mm)

R87F-A□A13

Specifications

Ratings and Ordering Information

Note: An asterisk (*) indicates a nominal value.

Item Model	Rated voltage (V)	Permitted voltage fluctuation range (%)	Frequency (Hz)	Rated current (A) *		Rated input (W) *		Rated rotational speed (r/min) *		Maximum flow rate (m ³ /min) *		Maximum static pressure (Pa) *		Noise (dB) *	
				50 Hz	60 Hz	50 Hz	60 Hz	50 Hz	60 Hz	50 Hz	60 Hz	50 Hz	60 Hz	50 Hz	60 Hz
R87F-A1A13HP	100	85% to 110% rated voltage	50/60	0.180	0.150	14	12	2,400	2,800	1.9	2.2	44.1	42.2	39	43
R87F-A3A13HP	115			0.160	0.130										
R87F-A4A13HP	200			0.096	0.078										
R87F-A6A13HP	230			0.085	0.068										
R87F-A1A13LP	100	85% to 110% rated voltage	50/60	0.140	0.110	12	10	1,700	2,000	1.3	1.5	19.6	23.5	32	34
R87F-A3A13LP	115			0.130	0.100										
R87F-A4A13LP	200			0.070	0.055										
R87F-A6A13LP	230			0.052	0.045										

Characteristics

Motor type	Single-phase shading coil induction motor (2-pole, open type)
Terminal type	Terminals
Insulation class	IEC class B (130°C) UL class A (105°C) CSA class A (105°C)
Insulation resistance	100 MΩ min. (at 500 VDC) between all power supply connections and uncharged metal parts.
Insulation withstand voltage	2,000 VAC (1 minute) between all power supply connections and uncharged metal parts.
Ambient operating temperature	-30 to 70°C (no icing)
Ambient storage temperature	-40 to 85°C (no icing)
Ambient humidity	25% to 85%
Protection	Impedance protection
Materials	Frame: Die-cast aluminum Blades: Glass polycarbonate
Bearings	Ball bearings
Weight	Approx. 350 g
Compliant standards	PSE, EN/IEC 60335 (CE marking compliant)
Certified standards	UL/CSA

Flow Rate and Static Pressure Characteristics (Reference Values)

R87F-A□A13HP

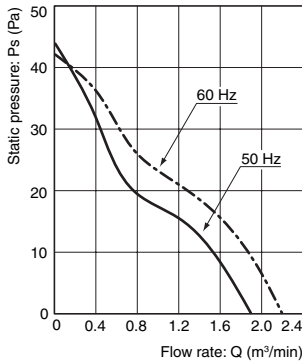

R87F-A□A13LP

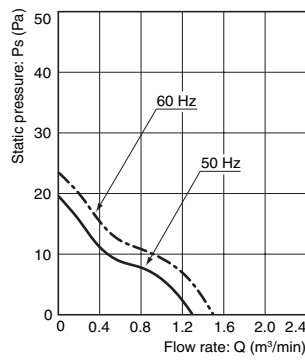

Note: For details on measurement conditions, refer to *Flow Rate and Static Pressure on Safety Precautions for All Axial Fans*.

Dimensions

(Unit: mm)

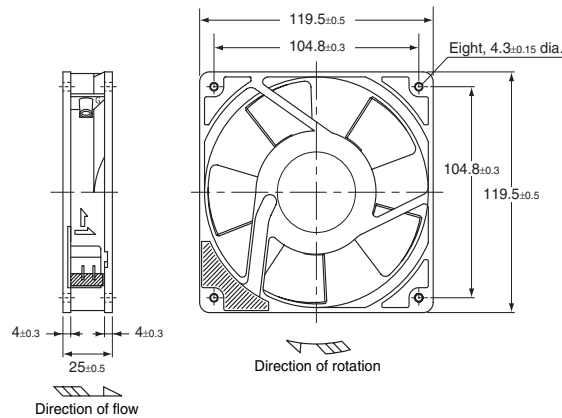

Screw hole for grounding



M4 screw: 0.7 pitch

Terminal shape



Faston #110 terminal (or equivalent)

Panel Cutouts

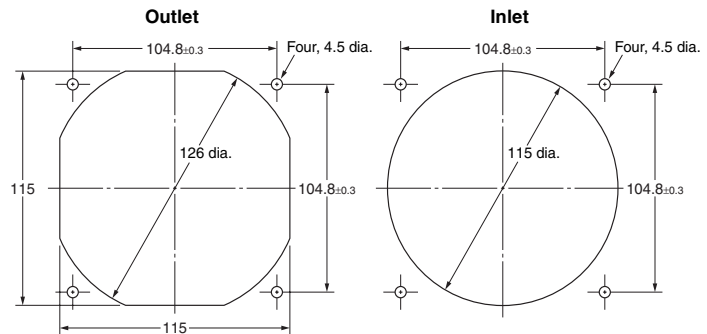

Options

Name	Model	Datasheet available
Plug Cord	R87F-PC	Refer to page 24.
Finger Guard	R87F-FG120	Refer to page 25.
Filter	R87F-FL120(S)	Refer to page 26.

ALL DIMENSIONS SHOWN ARE IN MILLIMETERS.
To convert millimeters into inches, multiply by 0.03937. To convert grams into ounces, multiply by 0.03527.

In the interest of product improvement, specifications are subject to change without notice.

R87F-A□A93

Specifications

Ratings and Ordering Information

Note: An asterisk (*) indicates a nominal value.

Item Model	Rated voltage (V)	Permitted voltage fluctuation range (%)	Frequency (Hz)	Rated current (A) *		Rated input (W) *		Rated rotational speed (r/min) *		Maximum flow rate (m ³ /min) *		Maximum static pressure (Pa) *		Noise (dB) *	
				50 Hz	60 Hz	50 Hz	60 Hz	50 Hz	60 Hz	50 Hz	60 Hz	50 Hz	60 Hz	50 Hz	60 Hz
R87F-A1A93HP	100	85% to 110% rated voltage	50/60	0.150	0.130	13	11	2,550	3,050	0.9	1.0	49.0	68.6	33	36
R87F-A3A93HP	115			0.125	0.100										
R87F-A4A93HP	200			0.070	0.060										
R87F-A6A93HP	230			0.055	0.050										
R87F-A1A93LP	100	85% to 110% rated voltage	50/60	0.100	0.085	7	6	1,900	2,200	0.7	0.8	24.5	34.3	29	32
R87F-A3A93LP	115			0.090	0.075										
R87F-A4A93LP	200			0.050	0.043										
R87F-A6A93LP	230			0.045	0.040										

Characteristics

Motor type	Single-phase shading coil induction motor (2-pole, open type)
Terminal type	Terminals
Insulation class	IEC class B (130°C) UL class A (105°C) CSA class A (105°C)
Insulation resistance	100 MΩ min. (at 500 VDC) between all power supply connections and uncharged metal parts.
Insulation withstand voltage	2,000 VAC (1 minute) between all power supply connections and uncharged metal parts.
Ambient operating temperature	-30 to 70°C (no icing)
Ambient storage temperature	-40 to 85°C (no icing)
Ambient humidity	25% to 85%
Protection	Impedance protection
Materials	Frame: Die-cast aluminum Blades: Glass polycarbonate
Bearings	Ball bearings
Weight	Approx. 300 g
Compliant standards	PSE, EN/IEC 60335 (CE marking compliant)
Certified standards	UL/CSA

Flow Rate and Static Pressure Characteristics (Reference Values)

R87F-A□A93HP

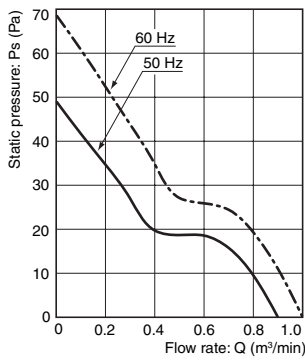

R87F-A□A93LP

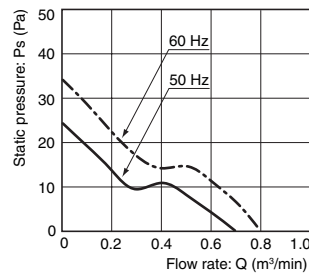

Note: For details on measurement conditions, refer to *Flow Rate and Static Pressure on Safety Precautions for All Axial Fans*.

Dimensions

(Unit: mm)

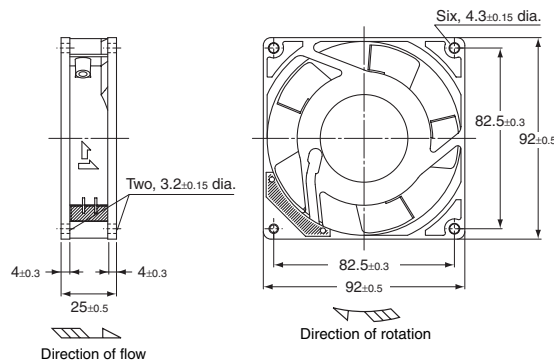

Screw hole for grounding



M4 screw: 0.7 pitch

Terminal shape



Faston #110 terminal (or equivalent)

Panel Cutouts

Panel cutting reference dimensions (note 3 mounting holes)

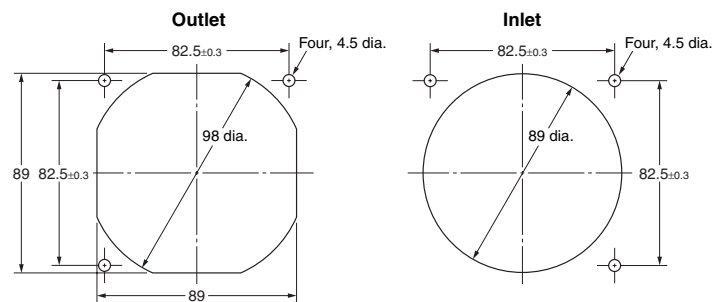

Options

Name	Model	Datasheet available
Plug Cord	R87F-PC	Refer to page 24.
Finger Guard	R87F-FG90	Refer to page 25.
Filter	R87F-FL90	Refer to page 26.

ALL DIMENSIONS SHOWN ARE IN MILLIMETERS.
To convert millimeters into inches, multiply by 0.03937. To convert grams into ounces, multiply by 0.03527.

In the interest of product improvement, specifications are subject to change without notice.

R87F-A□A85

Specifications

Ratings and Ordering Information

Note: An asterisk (*) indicates a nominal value.

Item Model	Rated voltage (V)	Permitted voltage fluctuation range (%)	Frequency (Hz)	Rated current (A) *		Rated input (W) *		Rated rotational speed (r/min) *		Maximum flow rate (m ³ /min) *		Maximum static pressure (Pa) *		Noise (dB) *	
				50 Hz	60 Hz	50 Hz	60 Hz	50 Hz	60 Hz	50 Hz	60 Hz	50 Hz	60 Hz	50 Hz	60 Hz
R87F-A1A85HP	100	85% to 110% rated voltage	50/60	0.140	0.115	10	9	2,700	3,200	0.8	0.9	42.1	58.8	32	36
R87F-A3A85HP	115			0.120	0.100										
R87F-A4A85HP	200			0.080	0.060										
R87F-A6A85HP	230			0.060	0.050										
R87F-A1A85LP	100	85% to 110% rated voltage	50/60	0.090	0.080	7	6	2,200	2,500	0.6	0.7	25.0	32.0	26	29
R87F-A3A85LP	115			0.080	0.070										
R87F-A4A85LP	200			0.050	0.040										
R87F-A6A85LP	230			0.040	0.040										

Characteristics

Motor type	Single-phase shading coil induction motor (2-pole, open type)
Terminal type	Terminals
Insulation class	IEC class B (130°C) UL class A (105°C) CSA class A (105°C)
Insulation resistance	100 MΩ min. (at 500 VDC) between all power supply connections and uncharged metal parts.
Insulation withstand voltage	2,000 VAC (1 minute) between all power supply connections and uncharged metal parts.
Ambient operating temperature	-30 to 70°C (no icing)
Ambient storage temperature	-40 to 85°C (no icing)
Ambient humidity	25% to 85%
Protection	Impedance protection
Materials	Frame: Die-cast aluminum Blades: Glass polycarbonate
Bearings	Ball bearings
Weight	Approx. 280 g
Compliant standards	PSE, EN/IEC 60335 (CE marking compliant)
Certified standards	UL/CSA

Flow Rate and Static Pressure Characteristics (Reference Values)

R87F-A□A85HP

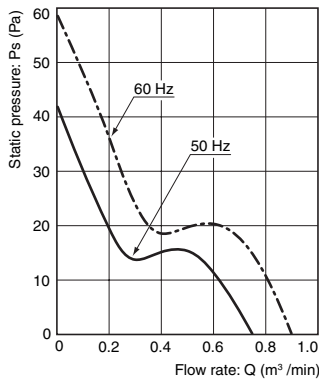

R87F-A□A85LP

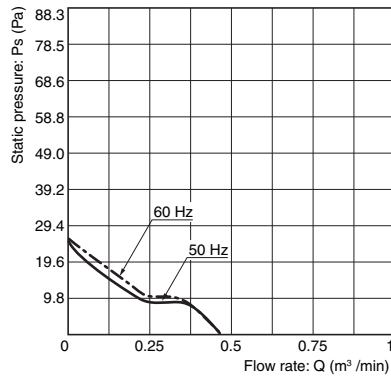

Note: For details on measurement conditions, refer to *Flow Rate and Static Pressure on Safety Precautions for All Axial Fans*.

Dimensions

(Unit: mm)

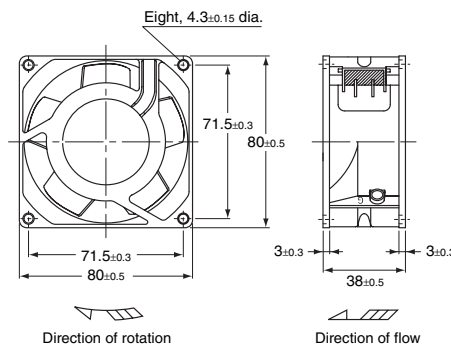

Screw hole for grounding

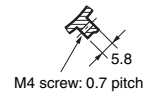

Terminal shape



Faston #110 terminal (or equivalent)

Panel Cutouts

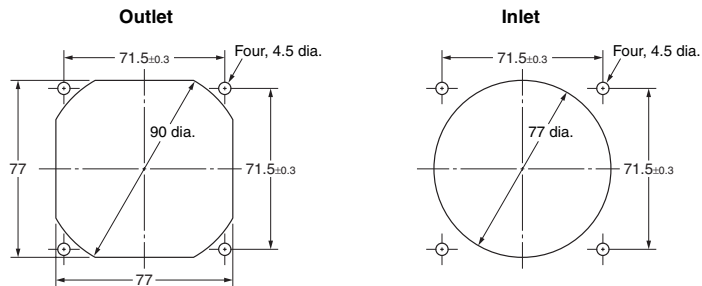

Options

Name	Model	Datasheet available
Plug Cord	R87F-PC	Refer to page 24.
Finger Guard	R87F-FG80	Refer to page 25.
Filter	R87F-FL80	Refer to page 26.

ALL DIMENSIONS SHOWN ARE IN MILLIMETERS.
To convert millimeters into inches, multiply by 0.03937. To convert grams into ounces, multiply by 0.03527.

In the interest of product improvement, specifications are subject to change without notice.

R87F-A□A83

Specifications

Ratings and Ordering Information

Note: An asterisk (*) indicates a nominal value.

Item Model	Rated voltage (V)	Permitted voltage fluctuation range (%)	Frequency (Hz)	Rated current (A) *		Rated input (W) *		Rated rotational speed (r/min) *		Maximum flow rate (m ³ /min) *		Maximum static pressure (Pa) *		Noise (dB) *	
				50 Hz	60 Hz	50 Hz	60 Hz	50 Hz	60 Hz	50 Hz	60 Hz	50 Hz	60 Hz	50 Hz	60 Hz
R87F-A1A83H	100	85% to 110% rated voltage	50/60	0.097	0.080	7	6	2,600	3,000	0.6	0.7	39.2	53.9	32	36
R87F-A3A83H	115			0.085	0.070										
R87F-A4A83H	200			0.048	0.041										
R87F-A6A83H	230			0.046	0.039										
R87F-A1A83L	100	85% to 110% rated voltage	50/60	0.063	0.055	5	4	1,900	2,100	0.4	0.5	19.5	23.5	28	30
R87F-A3A83L	115			0.055	0.048										
R87F-A4A83L	200			0.033	0.030										
R87F-A6A83L	230			0.028	0.024										

Characteristics

Motor type	Single-phase shading coil induction motor (2-pole, open type)
Terminal type	Lead wires
Insulation class	IEC class B (130°C) UL class A (105°C) CSA class A (105°C)
Insulation resistance	100 MΩ min. (at 500 VDC) between all power supply connections and uncharged metal parts.
Insulation withstand voltage	2,000 VAC (1 minute) between all power supply connections and uncharged metal parts.
Ambient operating temperature	-30 to 70°C (no icing)
Ambient storage temperature	-40 to 85°C (no icing)
Ambient humidity	25% to 85%
Protection	Impedance protection
Materials	Frame: Die-cast aluminum Blades: Glass polycarbonate
Bearings	Ball bearings
Weight	Approx. 230 g
Compliant standards	EN/IEC 60335 (CE marking compliant)
Certified standards	UL/CSA

Flow Rate and Static Pressure Characteristics (Reference Values)

R87F-A□A83H

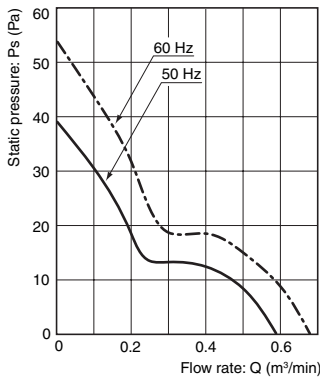

R87F-A□A83L

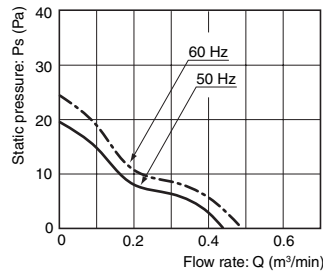

Note: For details on measurement conditions, refer to *Flow Rate and Static Pressure on Safety Precautions for All Axial Fans*.

Dimensions

(Unit: mm)

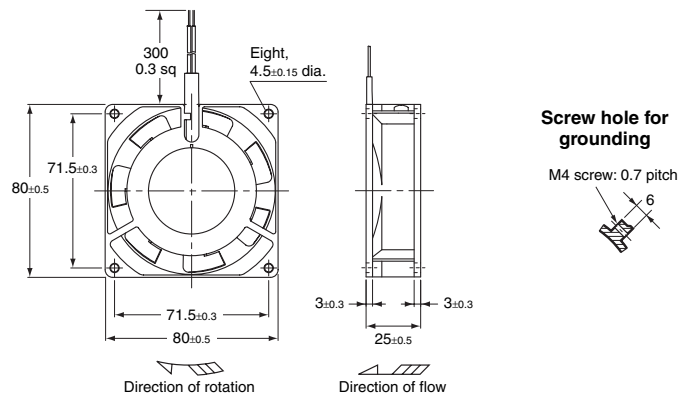

Panel Cutouts

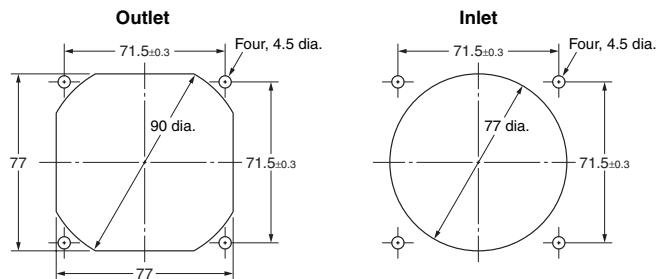

Options

Names	Model	Datasheet available
Finger Guard	R87F-FG80	Refer to page 25.
Filter	R87F-FL80	Refer to page 26.

ALL DIMENSIONS SHOWN ARE IN MILLIMETERS.
To convert millimeters into inches, multiply by 0.03937. To convert grams into ounces, multiply by 0.03527.

In the interest of product improvement, specifications are subject to change without notice.

R87T-A□A15H-WR

Specifications

Ratings and Ordering Information

Note: An asterisk (*) indicates a nominal value.

Item Model	Rated voltage (V)	Permitted voltage fluctuation range (%)	Frequency (Hz)	Rated current (A) *		Rated input (W) *		Rated rotational speed (r/min) *		Maximum flow rate (m ³ /min) *		Maximum static pressure (Pa) *		Noise (dB) *	
				50 Hz	60 Hz	50 Hz	60 Hz	50 Hz	60 Hz	50 Hz	60 Hz	50 Hz	60 Hz	50 Hz	60 Hz
R87T-A1A15H-WR	100	85% to 110% rated voltage	50/60	0.350	0.280	22	20	2,550	2,900	2.7	3.2	75.0	80.0	42	46
R87T-A3A15H-WR	115			0.300	0.240										
R87T-A4A15H-WR	200			0.170	0.135	15 to 22									
R87T-A6A15H-WR	200 to 230			0.145	0.115										

Characteristics

Motor type	Single-phase shading coil induction motor (2-pole, open type)	
Terminal type	Lead wires	
Insulation class	IEC class B (130°C) UL class A (105°C) CSA class A (105°C)	
Insulation resistance	100 MΩ min. (at 500 VDC) between all power supply connections and uncharged metal parts.	
Insulation withstand voltage	2,000 VAC (1 minute) between all power supply connections and uncharged metal parts.	
Degree of protection	IP X7	
Ambient operating temperature	-20 to 70°C (no icing)	
Ambient storage temperature	-40 to 85°C (no icing)	
Ambient humidity	95% max.	
Protection	Impedance protection	
Materials	Frame	Die-cast aluminum Black coating
	Blades	Zinc die-cast
Bearings	Ball bearings	
Weight	Approx. 650 g	
Standards	EN/IEC 60335 (CE marking compliant)	
Certified standards	cUL	

Flow Rate and Static Pressure Characteristics (Reference Values)

R87T-A□A15H-WR

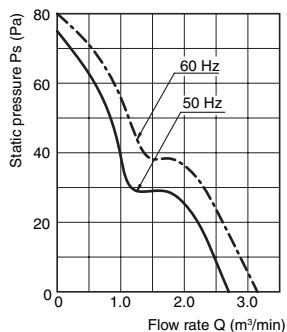

Note: For details on measurement conditions, refer to *Flow Rate and Static Pressure on Safety Precautions for All Axial Fans*.

Dimensions

(Unit: mm)

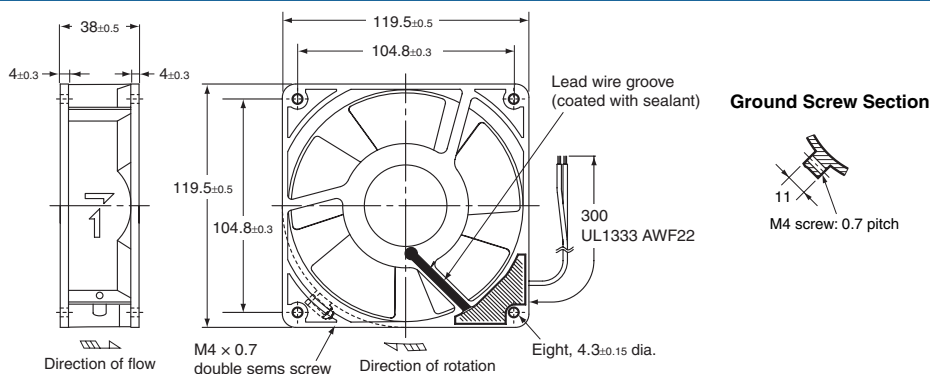

Panel Cutouts

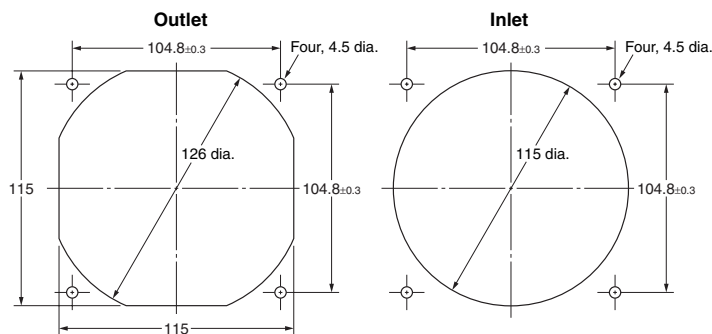

Options

Name	Model	Page number
Finger Guard	R87F-FG120	Refer to page 25.
Filter	R87F-FL120(S)	Refer to page 26.

ALL DIMENSIONS SHOWN ARE IN MILLIMETERS.
To convert millimeters into inches, multiply by 0.03937. To convert grams into ounces, multiply by 0.03527.

In the interest of product improvement, specifications are subject to change without notice.

R87T-A□A07

Specifications

Ratings and Ordering Information

Note: An asterisk (*) indicates a nominal value.

Item Model	Rated voltage (V)	Permitted voltage fluctuation range (%)	Frequency (Hz)	Rated current (A) *		Rated input (W) *		Rated rotational speed (r/min) *		Maximum flow rate (m ³ /min) *		Maximum static pressure (Pa) *		Noise (dB) *	
				50 Hz	60 Hz	50 Hz	60 Hz	50 Hz	60 Hz	50 Hz	60 Hz	50 Hz	60 Hz	50 Hz	60 Hz
R87T-A1A07H	100	85% to 110% rated voltage	50/60	0.480	0.420	43	40	2,800	3,250	5.0	5.8	118	88	52	56
R87T-A3A07H	115			0.420	0.370										
R87T-A4A07H	200			0.240	0.210										
R87T-A6A07H	230			0.210	0.190										

Characteristics

Motor type	Single-phase shading coil induction motor (2-pole, open type)
Terminal type	Lead wires
Insulation class	IEC class B (130°C) UL class A (105°C)
Insulation resistance	100 MΩ min. (at 500 VDC) between all power supply connections and uncharged metal parts.
Insulation withstand voltage	2,000 VAC (1 minute) between all power supply connections and uncharged metal parts.
Ambient operating temperature	-20 to 70°C (no icing)
Ambient storage temperature	-40 to 85°C (no icing)
Ambient humidity	25% to 85%
Protection	Thermal protection
Materials	Frame: Die-cast aluminum Blades: Steel plate (black coating)
Bearings	Ball bearings
Weight	Approx. 1,200 g
Compliant standards	EN/IEC 60335 (CE marking compliant)
Certified standards	UL

Flow Rate and Static Pressure Characteristics (Reference Value)

R87T-A□A07H

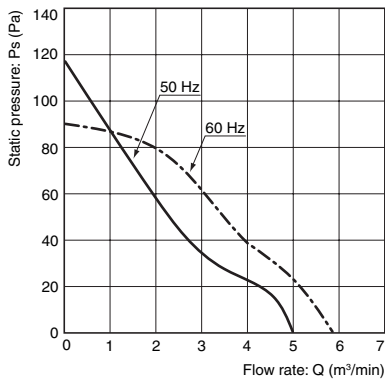

Note: For details on measurement conditions, refer to *Flow Rate and Static Pressure on Safety Precautions for All Axial Fans*.

Dimensions

(Unit: mm)

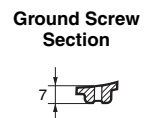
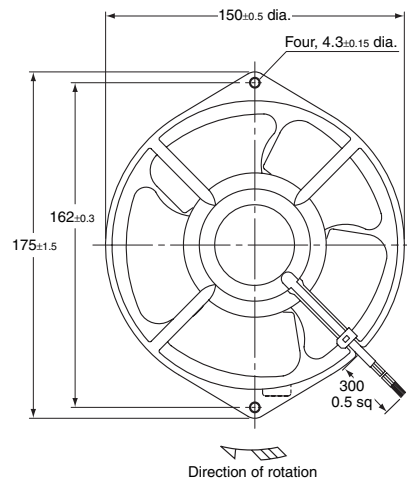
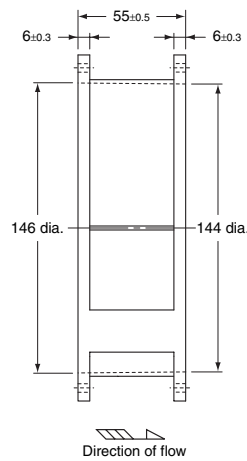

Panel Cutouts

Outlet and Inlet

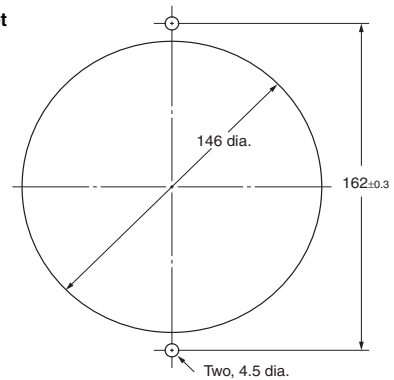

Options

Name	Model	Datasheet available
Finger Guard	R87F-FG150	Refer to page 25.

ALL DIMENSIONS SHOWN ARE IN MILLIMETERS.
To convert millimeters into inches, multiply by 0.03937. To convert grams into ounces, multiply by 0.03527.

In the interest of product improvement, specifications are subject to change without notice.

R87T-A□A05

Specifications

Ratings and Ordering Information

Note: An asterisk (*) indicates a nominal value.

Item Model	Rated voltage (V)	Permitted voltage fluctuation range (%)	Frequency (Hz)	Rated current (A) *		Rated input (W) *		Rated rotational speed (r/min) *		Maximum flow rate (m ³ /min) *		Maximum static pressure (Pa) *		Noise (dB) *	
				50 Hz	60 Hz	50 Hz	60 Hz	50 Hz	60 Hz	50 Hz	60 Hz	50 Hz	60 Hz	50 Hz	60 Hz
R87T-A1A05H	100	85% to 110% rated voltage	50/60	0.550	0.460	50	48	2,650	3,100	4.8	5.7	104	107	56	58
R87T-A3A05H	115			0.470	0.390										
R87T-A4A05H	200			0.260	0.220										
R87T-A6A05H	230			0.220	0.190										

Characteristics

Motor type	Single-phase shading coil induction motor (2-pole, open type)
Terminal type	Lead wires
Insulation class	IEC class B (130°C) UL class A (105°C)
Insulation resistance	100 MΩ min. (at 500 VDC) between all power supply connections and uncharged metal parts.
Insulation withstand voltage	2,000 VAC (1 minute) between all power supply connections and uncharged metal parts.
Ambient operating temperature	-20 to 70°C (no icing)
Ambient storage temperature	-40 to 85°C (no icing)
Ambient humidity	25% to 85%
Protection	Thermal protection
Materials	Frame: Die-cast aluminum Blades: Steel plate (mat black baked coating)
Bearings	Ball bearings
Weight	Approx. 840 g
Compliant standards	EN/IEC 60335 (CE marking compliant)
Certified standards	UL

Flow Rate and Static Pressure Characteristics (Reference Value)

R87T-A□A05H

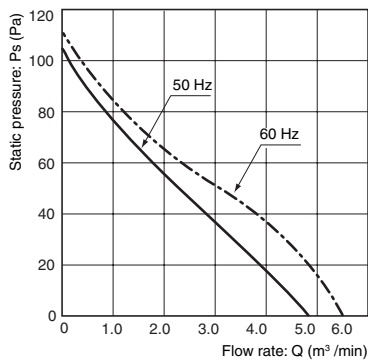

Note: For details on measurement conditions, refer to *Flow Rate and Static Pressure on Safety Precautions for All Axial Fans*.

Dimensions

(Unit: mm)

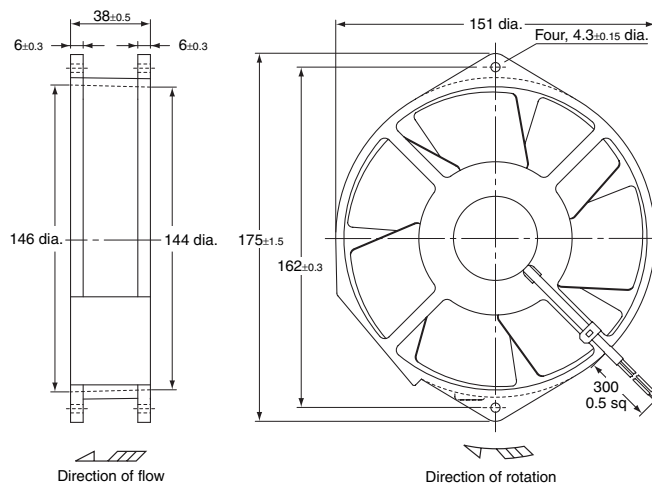

Ground Screw Section



Panel Cutouts

Outlet and Inlet

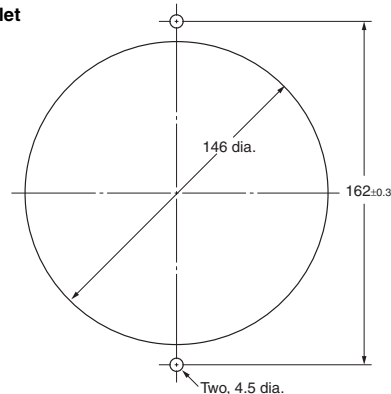

Options

Name	Model	Datasheet available
Finger Guard	R87F-FG150	Refer to page 25.

ALL DIMENSIONS SHOWN ARE IN MILLIMETERS.
To convert millimeters into inches, multiply by 0.03937. To convert grams into ounces, multiply by 0.03527.

In the interest of product improvement, specifications are subject to change without notice.

R87T-A□A15

Specifications

Ratings and Ordering Information

Note: An asterisk (*) indicates a nominal value.

Item Model	Rated voltage (V)	Permitted voltage fluctuation range (%)	Frequency (Hz)	Rated current (A) *		Rated input (W) *		Rated rotational speed (r/min) *		Maximum flow rate (m ³ /min) *		Maximum static pressure (Pa) *		Noise (dB) *	
				50 Hz	60 Hz	50 Hz	60 Hz	50 Hz	60 Hz	50 Hz	60 Hz	50 Hz	60 Hz	50 Hz	60 Hz
R87T-A1A15HP	100	85% to 110% rated voltage	50/60	0.250	0.210	20	18	2,700	3,100	2.6	3.0	66.6	58.8	42	46
R87T-A3A15HP	115			0.215	0.190										
R87T-A4A15HP	200			0.130	0.110										
R87T-A6A15HP	230			0.105	0.095										
R87T-A1A15MP	100	85% to 110% rated voltage	50/60	0.220	0.190	16	14	2,350	2,750	1.7	2.0	36.7	37.3	36	40
R87T-A3A15MP	115			0.200	0.170										
R87T-A4A15MP	200			0.110	0.100										
R87T-A6A15MP	230			0.100	0.085										

Characteristics

Motor type	Single-phase shading coil induction motor (2-pole, open type)
Terminal type	Terminals
Insulation class	IEC class B (130°C) UL class A (105°C)
Insulation resistance	100 MΩ min. (at 500 VDC) between all power supply connections and uncharged metal parts.
Insulation withstand voltage	2,000 VAC (1 minute) between all power supply connections and uncharged metal parts.
Ambient operating temperature	-20 to 70°C (no icing)
Ambient storage temperature	-40 to 85°C (no icing)
Ambient humidity	25% to 85%
Protection	Impedance protection
Materials	Frame: Die-cast aluminum Blades: Steel plate (black coating)
Bearings	Ball bearings
Weight	Approx. 570 g
Compliant standards	PSE, EN/IEC 60335 (CE marking compliant)
Certified standards	UL

Flow Rate and Static Pressure Characteristics (Reference Values)

R87T-A□A15HP

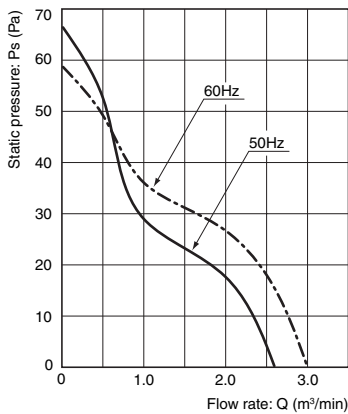

R87T-A□A15MP

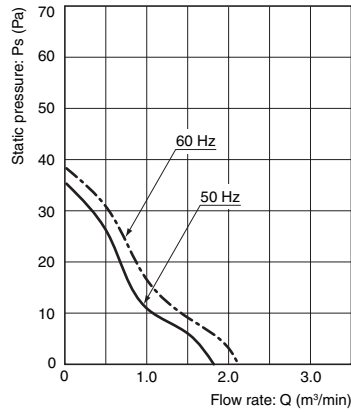

Note: For details on measurement conditions, refer to *Flow Rate and Static Pressure on Safety Precautions for All Axial Fans*.

Dimensions

(Unit: mm)

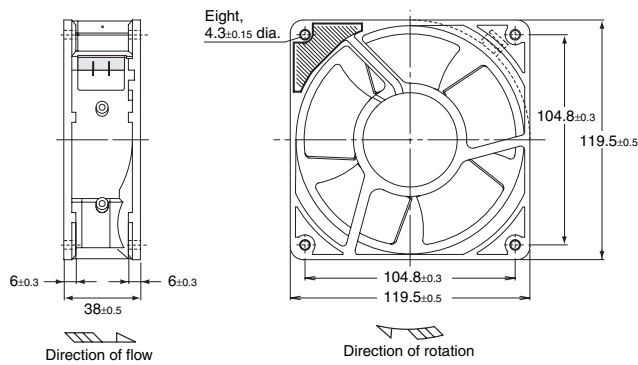

Screw hole for grounding



M4 screw: 0.7 pitch

Terminal shape



Faston #110 terminal (or equivalent)

Panel Cutouts

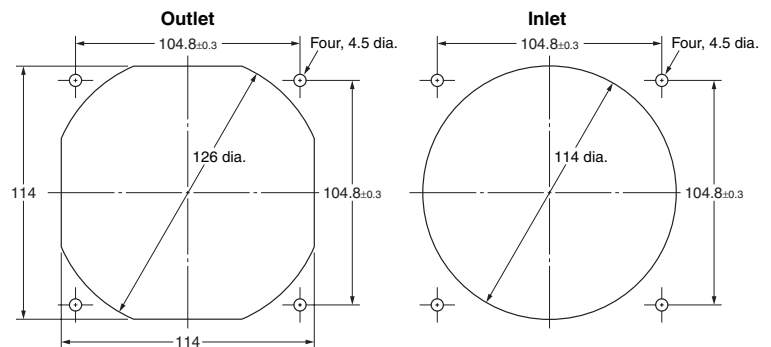

Options

Name	Model	Datasheet available
Plug Cord	R87F-PC	Refer to page 24.
Finger Guard	R87F-FG120	Refer to page 25.
Filter	R87F-FL120(S)	Refer to page 26.

ALL DIMENSIONS SHOWN ARE IN MILLIMETERS.

To convert millimeters into inches, multiply by 0.03937. To convert grams into ounces, multiply by 0.03527.

In the interest of product improvement, specifications are subject to change without notice.

R87T-A□A85

Specifications

Ratings and Ordering Information

Note: An asterisk (*) indicates a nominal value.

Item Model	Rated voltage (V)	Permitted voltage fluctuation range (%)	Frequency (Hz)	Rated current (A) *		Rated input (W) *		Rated rotational speed (r/min) *		Maximum flow rate (m ³ /min) *		Maximum static pressure (Pa) *		Noise (dB) *	
				50 Hz	60 Hz	50 Hz	60 Hz	50 Hz	60 Hz	50 Hz	60 Hz	50 Hz	60 Hz	50 Hz	60 Hz
R87T-A1A85H	100	85% to 110% rated voltage	50/60	0.180	0.160	12	10	2,800	3,300	0.80	0.90	42	58	37	40
R87T-A3A85H	115			0.155	0.135										
R87T-A4A85H	200			0.085	0.075										
R87T-A6A85H	230			0.080	0.070										

Characteristics

Motor type	Single-phase shading coil induction motor (2-pole, open type)
Terminal type	Lead wires
Insulation class	IEC class B (130°C) UL class A (105°C)
Insulation resistance	100 MΩ min. (at 500 VDC) between all power supply connections and uncharged metal parts.
Insulation withstand voltage	2,000 VAC (1 minute) between all power supply connections and uncharged metal parts.
Ambient operating temperature	-20 to 70°C (no icing)
Ambient storage temperature	-40 to 85°C (no icing)
Ambient humidity	25% to 85%
Protection	Impedance protection
Materials	Frame: Die-cast aluminum Blades: Steel plate (black coating)
Bearings	Ball bearings
Weight	Approx. 440 g
Compliant standards	EN/IEC 60335 (CE marking compliant)
Certified standards	UL

Flow Rate and Static Pressure Characteristics (Reference Values)

R87T-A□A85H

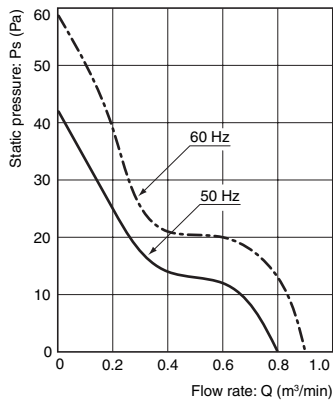

Note: For details on measurement conditions, refer to *Flow Rate and Static Pressure on Safety Precautions for All Axial Fans*.

Dimensions

(Unit: mm)

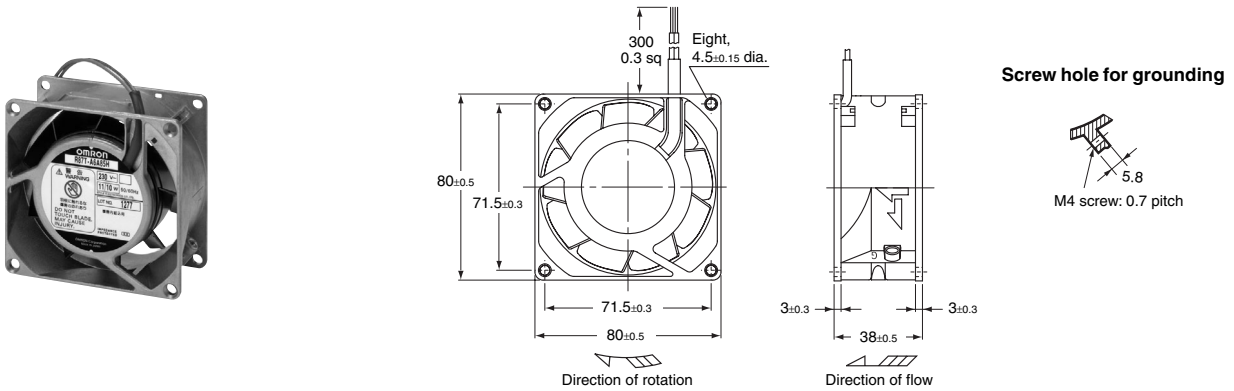

Panel Cutouts

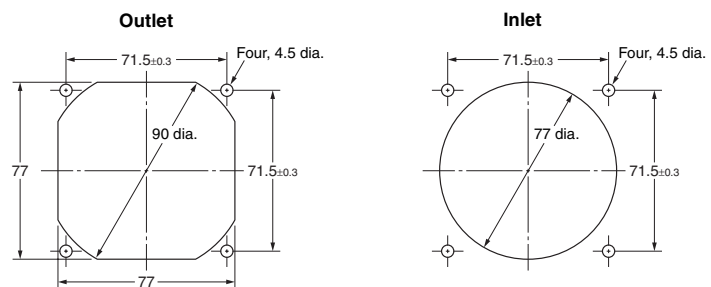

Options

Name	Model	Datasheet available
Finger Guard	R87F-FG80	Refer to page 25.
Filter	R87F-FL80	Refer to page 26.

ALL DIMENSIONS SHOWN ARE IN MILLIMETERS.
To convert millimeters into inches, multiply by 0.03937. To convert grams into ounces, multiply by 0.03527.

In the interest of product improvement, specifications are subject to change without notice.

R87T-A□A83

Specifications

Ratings and Ordering Information

Note: An asterisk (*) indicates a nominal value.

Item Model	Rated voltage (V)	Permitted voltage fluctuation range (%)	Frequency (Hz)	Rated current (A)*		Rated input (W)*		Rated rotational speed (r/min)*		Maximum flow rate (m ³ /min)*		Maximum static pressure (Pa)*		Noise (dB)*	
				50 Hz	60 Hz	50 Hz	60 Hz	50 Hz	60 Hz	50 Hz	60 Hz	50 Hz	60 Hz	50 Hz	60 Hz
R87T-A1A83H	100	85% to 110% rated voltage	50/60	0.180	0.150	12	11	2,500	3,000	0.5	0.6	34.0	49.0	33	36
R87T-A3A83H	115			0.150	0.130										
R87T-A4A83H	200			0.087	0.075										
R87T-A6A83H	230			0.075	0.065										

Characteristics

Motor type	Single-phase shading coil induction motor (2-pole, open type)	
Terminal type	Lead wires	
Insulation class	IEC class B (130°C) UL class A (105°C)	
Insulation resistance	100 MΩ min. (at 500 VDC) between all power supply connections and uncharged metal parts.	
Insulation withstand voltage	2,000 VAC (1 minute) between all power supply connections and uncharged metal parts.	
Ambient operating temperature	-20 to 70°C (no icing)	
Ambient storage temperature	-40 to 85°C (no icing)	
Ambient humidity	25% to 85%	
Protection	Impedance protection	
Materials	Frame	Die-cast aluminum
	Blades	Steel plate (black coating)
Bearings	Ball bearings	
Weight	Approx. 330 g	
Standards	EN/IEC 60335 (CE marking compliant)	
Certified standards	UL	

Flow Rate and Static Pressure Characteristics (Reference Values)

R87T-A □ A83H

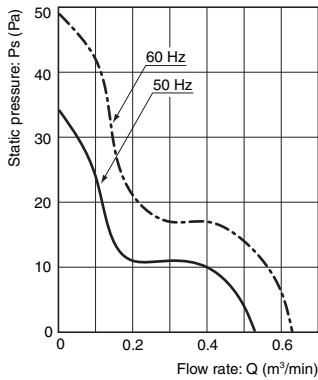

Note: For details on measurement conditions, refer to *Flow Rate and Static Pressure on Safety Precautions for All Axial Fans*.

Dimensions

(Unit: mm)

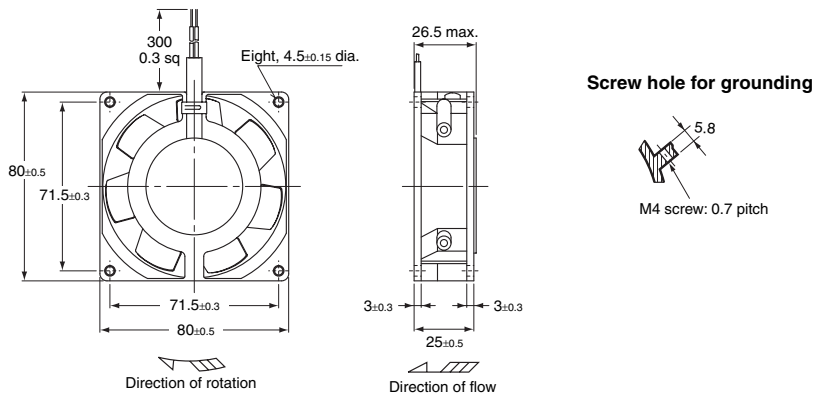

Panel Cutouts

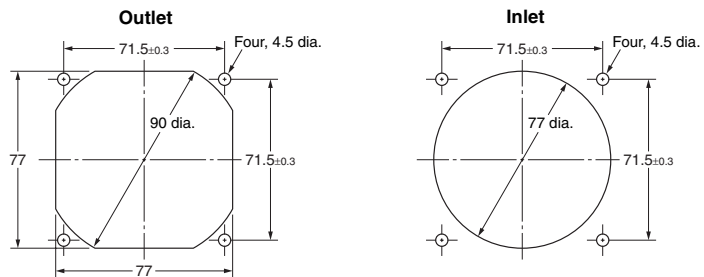

Options

Name	Model	Datasheet available
Finger Guard	R87F-FG80	Refer to page 25.
Filter	R87F-FL80	Refer to page 26.

ALL DIMENSIONS SHOWN ARE IN MILLIMETERS.
To convert millimeters into inches, multiply by 0.03937. To convert grams into ounces, multiply by 0.03527.

In the interest of product improvement, specifications are subject to change without notice.

Plug Cord R87F-PC

Accessories (Order Separately)

Available Models

Cord length	Model number	Weight (g)
1 m	R87F-PC	39
2 m	R87F-PC-20	69

R87F-PC Rating: 250 VAC, 3 A
UL-certified Plug Cord



Dimensions

(Unit: mm)

R87F-PC

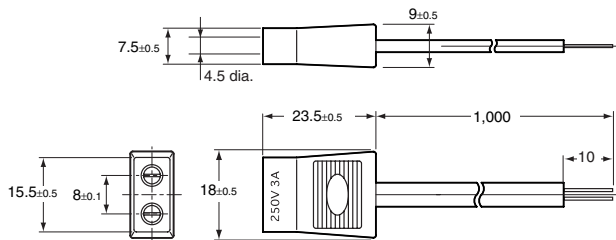

Connectable to Faston #110 terminals (or equivalent).

Note: This Plug Cord is used for Axial Fans with terminals.

ALL DIMENSIONS SHOWN ARE IN MILLIMETERS.
To convert millimeters into inches, multiply by 0.03937. To convert grams into ounces, multiply by 0.03527.

In the interest of product improvement, specifications are subject to change without notice.

Accessories (Order Separately)

Available Models

Size	Model number	Weight (g)
150 dia.	R87F-FG150	Approx. 58
120 × 120	R87F-FG120	Approx. 45
92 × 92	R87F-FG90	Approx. 25
80 × 80	R87F-FG80	Approx. 20

Applicable Axial Fans

AC Axial Fan		Finger Guard
Size	Model	
150 dia.	R87T-A□A0 Series	R87F-FG150
120 × 120	R87F-A□A1 Series R87T-A□A1 Series	R87F-FG120
92 × 92	R87F-A□A9 Series	R87F-FG90
80 × 80	R87F-A□A8 Series R87T-A□A8 Series	R87F-FG80

Note: Finger Guards reduce the flow rate by approximately 2% to 5%.

Dimensions

(Unit: mm)

Material: steel, Joints: spot welded, Surface: nickel-chrome plated

R87F-FG150

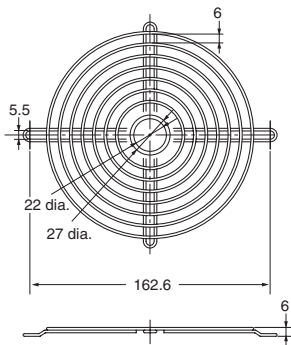

R87F-FG120

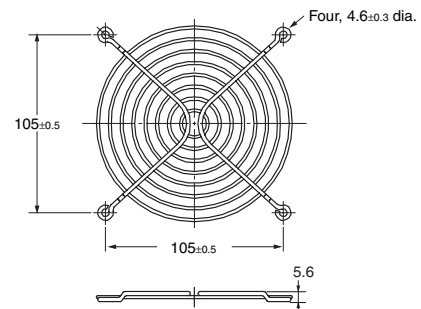

R87F-FG90

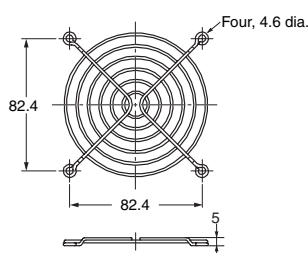

R87F-FG80

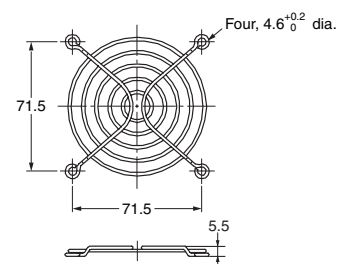

ALL DIMENSIONS SHOWN ARE IN MILLIMETERS.

To convert millimeters into inches, multiply by 0.03937. To convert grams into ounces, multiply by 0.03527.

In the interest of product improvement, specifications are subject to change without notice.

R87F-FL

Accessories (Order Separately)

Available Models

Size	Model number	Weight (g)
120 × 120	R87F-FL120	Approx. 43
92 × 92	R87F-FL90	Approx. 30
80 × 80	R87F-FL80	Approx. 21
120 × 120	R87F-FL120S	Approx. 19

Applicable Axial Fans

AC Axial Fan		Filter	
Size	Model	Plastic	Aluminum
150 dia.	R87T-A□A0 Series	---	---
120 × 120	R87F-A□A1 Series R87T-A□A1 Series	R87F-FL120	R87F-FL120S
92 × 92	R87F-A□A9 Series	R87F-FL90	---
80 × 80	R87F-A□A8 Series R87T-A□A8 Series	R87F-FL80	---

Note: Filters reduce the flow rate by approximately 20% to 40%. Ensure that there is no clogging.

R87F-FL□ Plastic Filter

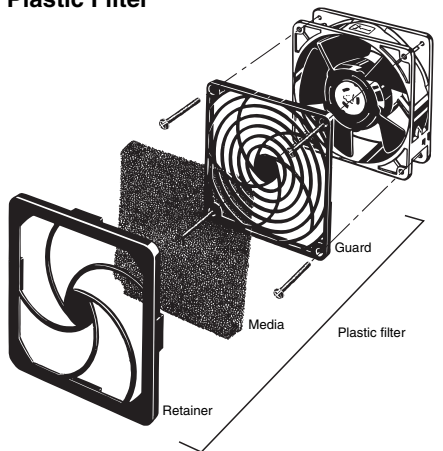

Mounting Method

1. Attach the guard to the Fan using the mounting bolts. (There are no mounting bolts provided with the Plastic Filter.)
2. With the media held between the retainer and the guard, hook the retainer to the guard. (The Media and retainer can be one-touch mounted/dismounted.)

Note: Use the following model number to order the Media only.
R87F-FL□-M□ (□: 120, 90, or 80)
(One set containing five Media, weight: 5 g max.)

R87F-FL120S Screen Filter

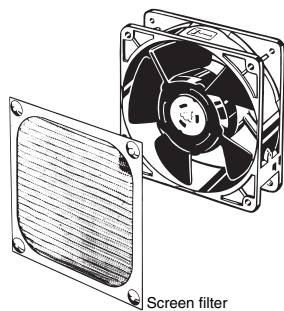

Dimensions

(Unit: mm)

R87F-FL120

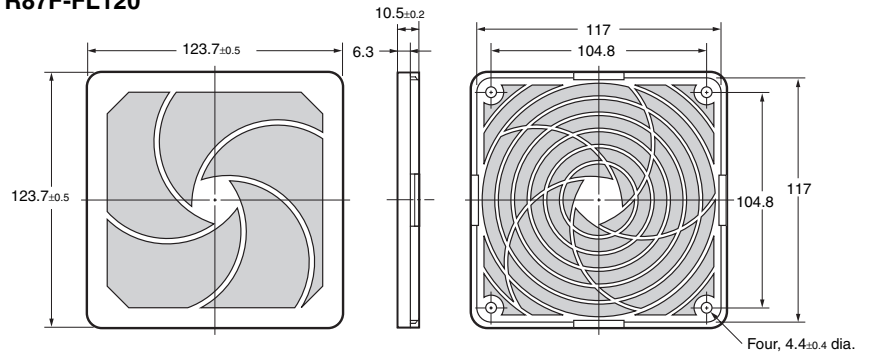

R87F-FL90

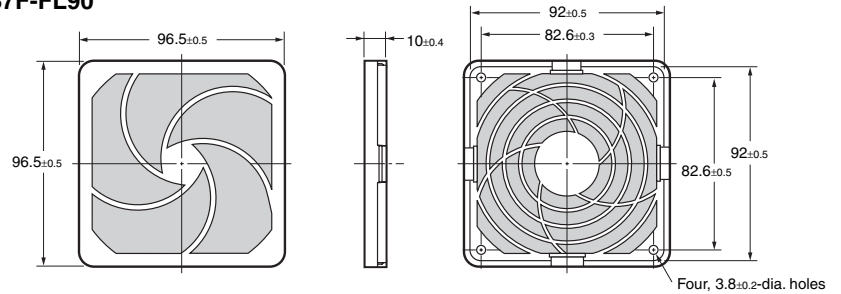

R87F-FL80

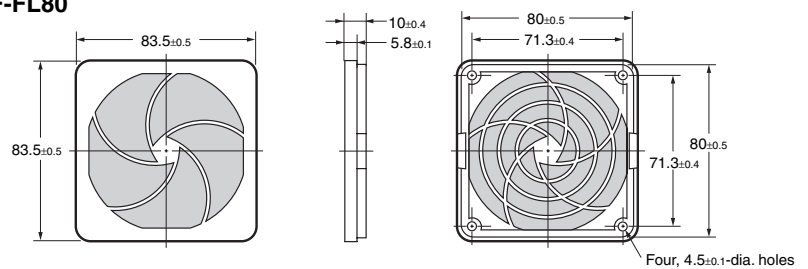

R87F-FL120S

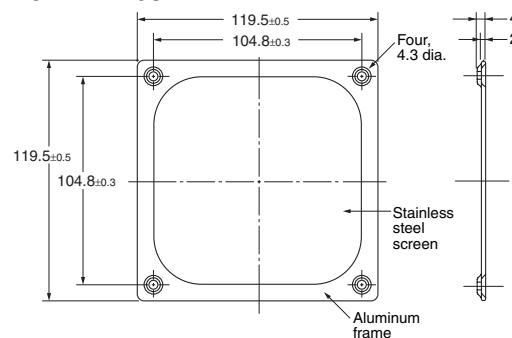

- Note:**
1. The Screen Filter is made using aluminum and has an **EMI/RFI** shielding effect.
 2. When mounting the Screen Filter, make sure that it does not come in contact with the fan blades.
 3. The screen is a 30 × 30 aluminum mesh.

ALL DIMENSIONS SHOWN ARE IN MILLIMETERS.
To convert millimeters into inches, multiply by 0.03937. To convert grams into ounces, multiply by 0.03527.

In the interest of product improvement, specifications are subject to change without notice.

Read and Understand This Catalog

Please read and understand this catalog before purchasing the products. Please consult your OMRON representative if you have any questions or comments.

Warranty and Limitations of Liability

WARRANTY

OMRON's exclusive warranty is that the products are free from defects in materials and workmanship for a period of one year (or other period if specified) from date of sale by OMRON.

OMRON MAKES NO WARRANTY OR REPRESENTATION, EXPRESS OR IMPLIED, REGARDING NON-INFRINGEMENT, MERCHANTABILITY, OR FITNESS FOR PARTICULAR PURPOSE OF THE PRODUCTS. ANY BUYER OR USER ACKNOWLEDGES THAT THE BUYER OR USER ALONE HAS DETERMINED THAT THE PRODUCTS WILL SUITABLY MEET THE REQUIREMENTS OF THEIR INTENDED USE. OMRON DISCLAIMS ALL OTHER WARRANTIES, EXPRESS OR IMPLIED.

LIMITATIONS OF LIABILITY

OMRON SHALL NOT BE RESPONSIBLE FOR SPECIAL, INDIRECT, OR CONSEQUENTIAL DAMAGES, LOSS OF PROFITS OR COMMERCIAL LOSS IN ANY WAY CONNECTED WITH THE PRODUCTS, WHETHER SUCH CLAIM IS BASED ON CONTRACT, WARRANTY, NEGLIGENCE, OR STRICT LIABILITY.

In no event shall the responsibility of OMRON for any act exceed the individual price of the product on which liability is asserted.

IN NO EVENT SHALL OMRON BE RESPONSIBLE FOR WARRANTY, REPAIR, OR OTHER CLAIMS REGARDING THE PRODUCTS UNLESS OMRON'S ANALYSIS CONFIRMS THAT THE PRODUCTS WERE PROPERLY HANDLED, STORED, INSTALLED, AND MAINTAINED AND NOT SUBJECT TO CONTAMINATION, ABUSE, MISUSE, OR INAPPROPRIATE MODIFICATION OR REPAIR.

Application Considerations

SUITABILITY FOR USE

OMRON shall not be responsible for conformity with any standards, codes, or regulations that apply to the combination of products in the customer's application or use of the products.

At the customer's request, OMRON will provide applicable third party certification documents identifying ratings and limitations of use that apply to the products. This information by itself is not sufficient for a complete determination of the suitability of the products in combination with the end product, machine, system, or other application or use.

The following are some examples of applications for which particular attention must be given. This is not intended to be an exhaustive list of all possible uses of the products, nor is it intended to imply that the uses listed may be suitable for the products:

- Outdoor use, uses involving potential chemical contamination or electrical interference, or conditions or uses not described in this catalog.
- Nuclear energy control systems, combustion systems, railroad systems, aviation systems, medical equipment, amusement machines, vehicles, safety equipment, and installations subject to separate industry or government regulations.
- Systems, machines, and equipment that could present a risk to life or property.

Please know and observe all prohibitions of use applicable to the products.

NEVER USE THE PRODUCTS FOR AN APPLICATION INVOLVING SERIOUS RISK TO LIFE OR PROPERTY WITHOUT ENSURING THAT THE SYSTEM AS A WHOLE HAS BEEN DESIGNED TO ADDRESS THE RISKS, AND THAT THE OMRON PRODUCTS ARE PROPERLY RATED AND INSTALLED FOR THE INTENDED USE WITHIN THE OVERALL EQUIPMENT OR SYSTEM.

PROGRAMMABLE PRODUCTS

OMRON shall not be responsible for the user's programming of a programmable product, or any consequence thereof.

Disclaimers

CHANGE IN SPECIFICATIONS

Product specifications and accessories may be changed at any time based on improvements and other reasons.

It is our practice to change model numbers when published ratings or features are changed, or when significant construction changes are made. However, some specifications of the products may be changed without any notice. When in doubt, special model numbers may be assigned to fix or establish key specifications for your application on your request. Please consult with your OMRON representative at any time to confirm actual specifications of purchased products.

DIMENSIONS AND WEIGHTS

Dimensions and weights are nominal and are not to be used for manufacturing purposes, even when tolerances are shown.

PERFORMANCE DATA

Performance data given in this catalog is provided as a guide for the user in determining suitability and does not constitute a warranty. It may represent the result of OMRON's test conditions, and the users must correlate it to actual application requirements. Actual performance is subject to the OMRON Warranty and Limitations of Liability.

ERRORS AND OMISSIONS

The information in this document has been carefully checked and is believed to be accurate; however, no responsibility is assumed for clerical, typographical, or proofreading errors, or omissions.

2009.1

In the interest of product improvement, specifications are subject to change without notice.

OMRON Corporation
Industrial Automation Company

<http://www.ia.omron.com/>

(c)Copyright OMRON Corporation 2009 All Right Reserved.

Mouser Electronics

Authorized Distributor

Click to View Pricing, Inventory, Delivery & Lifecycle Information:

Omron:

[R87F-A1A13HP](#) [R87F-A1A15HP](#) [R87F-A1A85HP](#) [R87F-A1A93HP](#) [R87F-A3A13HP](#) [R87F-A3A15HP](#) [R87F-A3A83H](#) [R87F-A3A93HP](#) [R87F-A4A13HP](#) [R87F-A4A15HP](#) [R87F-A4A15MP](#) [R87F-A4A83L](#) [R87F-A4A85HP](#) [R87F-A4A93HP](#) [R87F-A6A93HP](#) [R87F-FG120](#) [R87F-FG80](#) [R87F-FG90](#) [R87F-FL120](#) [R87F-FL120S](#) [R87F-PC](#) [R87F-PC-20](#) [R87T-A1A15HP](#) [R87T-A1A15MP](#) [R87T-A3A15HP](#) [R87T-A4A05H](#) [R87T-A4A15HP](#) [R87T-A4A15MP](#) [R87T-A6A15HP](#) [R87T-A6A15MP](#) [R87F-FL80](#) [R87F-FL90](#) [R87T-A1A07H](#) [R87T-A1A15H-WR](#) [R87T-A3A15H-WR](#) [R87T-A4A15H-WR](#) [R87T-A6A15H-WR](#) [R87F-A3A15MP](#) [R87F-A3A93LP](#) [R87F-A6A85HP](#) [R87T-A4A07H](#) [R87T-A6A05H](#) [R87F-A1A83L](#) [R87F-A4A13LP](#) [R87F-A6A83H](#) [R87F-A1A83H](#) [R87F-A3A83L](#) [R87F-A6A13HP](#) [R87F-A1A13LP](#) [R87F-A1A85LP](#) [R87F-A4A83H](#) [R87F-A1A15MP](#) [R87F-A6A15LP](#) [R87T-A6A07H](#) [R87F-FG150](#) [R87F-A3A85HP](#) [R87T-A3A07H](#)



Компания «ЭлектроПласт» предлагает заключение долгосрочных отношений при поставках импортных электронных компонентов на взаимовыгодных условиях!

Наши преимущества:

- Оперативные поставки широкого спектра электронных компонентов отечественного и импортного производства напрямую от производителей и с крупнейших мировых складов;
- Поставка более 17-ти миллионов наименований электронных компонентов;
- Поставка сложных, дефицитных, либо снятых с производства позиций;
- Оперативные сроки поставки под заказ (от 5 рабочих дней);
- Экспресс доставка в любую точку России;
- Техническая поддержка проекта, помощь в подборе аналогов, поставка прототипов;
- Система менеджмента качества сертифицирована по Международному стандарту ISO 9001;
- Лицензия ФСБ на осуществление работ с использованием сведений, составляющих государственную тайну;
- Поставка специализированных компонентов (Xilinx, Altera, Analog Devices, Intersil, Interpoint, Microsemi, Aeroflex, Peregrine, Syfer, Eurofarad, Texas Instrument, Miteq, Cobham, E2V, MA-COM, Hittite, Mini-Circuits, General Dynamics и др.);

Помимо этого, одним из направлений компании «ЭлектроПласт» является направление «Источники питания». Мы предлагаем Вам помощь Конструкторского отдела:

- Подбор оптимального решения, техническое обоснование при выборе компонента;
- Подбор аналогов;
- Консультации по применению компонента;
- Поставка образцов и прототипов;
- Техническая поддержка проекта;
- Защита от снятия компонента с производства.

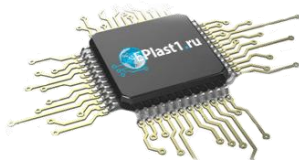

Как с нами связаться

Телефон: 8 (812) 309 58 32 (многоканальный)

Факс: 8 (812) 320-02-42

Электронная почта: org@eplast1.ru

Адрес: 198099, г. Санкт-Петербург, ул. Калинина, дом 2, корпус 4, литера А.