

BMZ SERIES BATTERY POST MOUNT ZCASE® FUSE HOLDER

275A • 32V DC • 2-way or 3-way • ZCASE®



Description

The BMZ battery post mount fuse holder allows you to mount fusing directly to a post style battery terminal. The BMZ series accepts the Littelfuse proprietary ZCASE fuse that is available in 80-600A ratings with similar characteristics to the MEGA® fuse. The BMZ post mount fuse holder mounts directly to the battery without any need for additional mounting hardware and is available in 2 or 3-pole versions (see image above). The insulated bolt on the busbar eliminates the traditional need for nylon nuts used on legacy CF8 fuses. The ZCASE fuses can be assembled using a standard M8 flange nut. Fuse mounting nuts are included with the boxed kits but need to be sourced separately when ordering individual components.

The BMZ post mount fuse holder features a compact design which saves space and eliminates the need to wire in a separate fuse holder or power distribution module. Additional circuits are added to the battery directly on top of the ZCASE fuse with wired ring terminals. The fuse holder is available in individual component part numbers and in a complete boxed kit.

Ordering Information

PART NUMBERS		POSITIONS	DESCRIPTION
BULK	BOXED KIT		
-	0FHZ00854-BX	2	Kit: 882-854 (2 way bus bar), 876-199 (terminal mount), 901-325 (red cover), 1X M8 Bolt, 3x M8 Nuts
-	0FHZ00853-BX	3	Kit: 882-853 (3 way bus bar), 876-199 (terminal mount), 901-325 (red cover), 3x M8 Nuts
882-854	-	2	2 Way Bus Bar & Stud Assembly
882-853	-	3	3 Way Bus Bar & Stud Assembly
876-199	-	-	Battery Terminal
901-325	-	-	Red Rubber 2 or 3 Way Cover
32980001ZXM8	-	-	ZCASE Bolt with 3 Snap Fit

Features and Benefits

- Mounts directly to a post style of battery
- Available in 2 or 3 pole designs
- Uses ZCASE single Fuses (M8) available 40-600A
- Maximum continuous throughput 275A
- Unlike other battery mount holders the BMZ series does not require a special nut due to isolated bus bar studs and can be installed using standard M8 nuts (sold separately)
- Fusing directly at the battery allows location of larger power distribution boxes outside of the engine compartment while assuring protection of the supply cables

Specifications

Max Voltage Rating:	32 V DC or max rating of the fuse
Max Continuous Current:	275A
Available Fuse Rating:	80-600A
Fuse Terminal Torque:	M8 Nut: 14 ± 2 Nm
Battery Terminal Torque:	5.4 ± 0.9 Nm @ 540 RPM
Operating Temp:	-40° to 125° C

Applications

- Mounts directly to a post style battery terminal
- Consolidate multiple fuse holders and reduce wiring
- High amperage starter circuit protection

Recommended Fuse



ZCASE® 40-600A Bolt-Down Fuses

Web Resources

Download 2D print, 3D model and more at:
littelfuse.com/bmz

BMZ SERIES BATTERY POST MOUNT ZCASE® FUSE HOLDER

Dimensions in millimeters

3-way bus bar

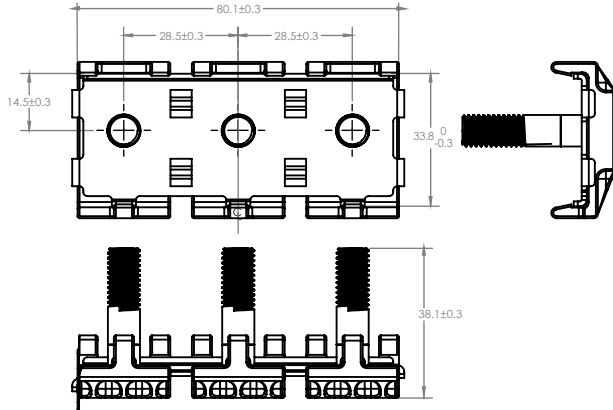

2-way bus bar

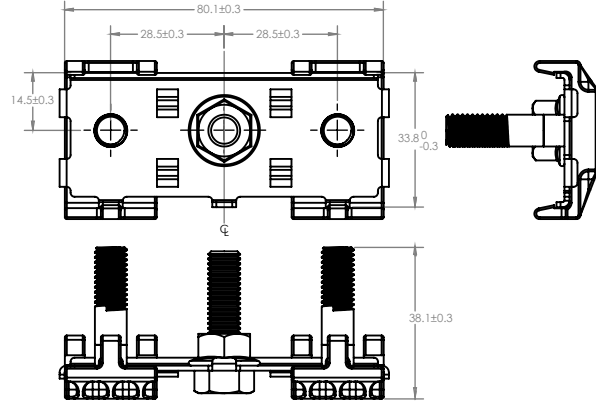

Battery Terminal

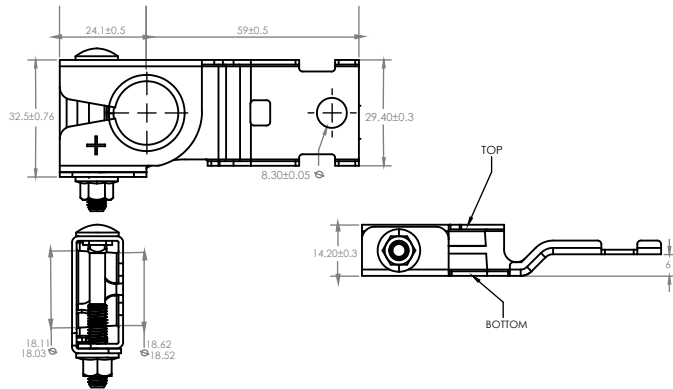

Cover

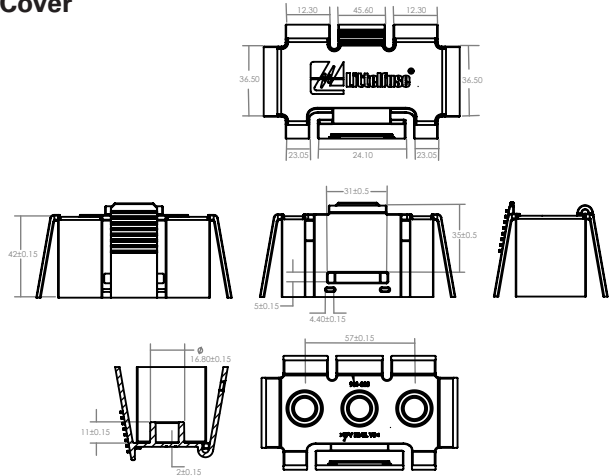

Related Products

ZCASE® • 40-600A • Bolt-Down Fuses

The ZCASE is a bolt down fuse with a wide rating range up to 600A. The Time Current characteristic is similar to the well known MEGA® design and can be used as full wire protection until 250A. Higher ratings typically used for starter fuse.

Learn more at: littelfuse.com/ZCASE



SMZ Series Stud Mount ZCASE® Fuse Holder

The SMZ stud mount fuse holder allows you to mount fusing directly to a M8 or M10 on applications such as batteries, alternators, battery switches or electrical relays. The SMZ stud mount fuse holder is ideal for stacking to create a 2 pole version.

Learn more at: littelfuse.com/SMZ



Visit Littelfuse.com for the most up-to-date product information. Littelfuse reserves the right to make product changes, without notice. Material in this document is as accurate as known at the time of publication.



Компания «ЭлектроПласт» предлагает заключение долгосрочных отношений при поставках импортных электронных компонентов на взаимовыгодных условиях!

Наши преимущества:

- Оперативные поставки широкого спектра электронных компонентов отечественного и импортного производства напрямую от производителей и с крупнейших мировых складов;
- Поставка более 17-ти миллионов наименований электронных компонентов;
- Поставка сложных, дефицитных, либо снятых с производства позиций;
- Оперативные сроки поставки под заказ (от 5 рабочих дней);
- Экспресс доставка в любую точку России;
- Техническая поддержка проекта, помощь в подборе аналогов, поставка прототипов;
- Система менеджмента качества сертифицирована по Международному стандарту ISO 9001;
- Лицензия ФСБ на осуществление работ с использованием сведений, составляющих государственную тайну;
- Поставка специализированных компонентов (Xilinx, Altera, Analog Devices, Intersil, Interpoint, Microsemi, Aeroflex, Peregrine, Syfer, Eurofarad, Texas Instrument, Miteq, Cobham, E2V, MA-COM, Hittite, Mini-Circuits, General Dynamics и др.);

Помимо этого, одним из направлений компании «ЭлектроПласт» является направление «Источники питания». Мы предлагаем Вам помощь Конструкторского отдела:

- Подбор оптимального решения, техническое обоснование при выборе компонента;
- Подбор аналогов;
- Консультации по применению компонента;
- Поставка образцов и прототипов;
- Техническая поддержка проекта;
- Защита от снятия компонента с производства.



Как с нами связаться

Телефон: 8 (812) 309 58 32 (многоканальный)

Факс: 8 (812) 320-02-42

Электронная почта: org@eplast1.ru

Адрес: 198099, г. Санкт-Петербург, ул. Калинина, дом 2, корпус 4, литера А.