

**HDP-20 Crimp Snap-In Contact Connectors**

Cable Connectors



**Product Selection Guide**

Connector				Contacts		
Type	Insert Material	Shell Type Material and Finish	Mounting	Type	Termination	Plating
Plug (pg. 92)	94V-0 Rated Thermoplastic Black	Zinc Plated Steel Without Grounding Indents	.120 [3.05] Dia. Holes Clinch Nut, 4-40 Threads	Pins (pgs. 100, 101)	Crimp  Posted	Duplex (.000030 [0.00076] Gold and Tin)
		Tin Plated Steel Without Grounding Indents				Duplex (Gold Flash and Tin)
		Tin Plated Steel With Grounding Indents				Select (.000030 [0.00076] Gold and Gold Flash)
Receptacle (pg. 93)	94V-0 Rated Thermoplastic Black	Zinc Plated Steel	.120 [3.05] Dia. Holes Clinch Nuts, 4-40 Threaded	Sockets (pgs. 100, 101)	Crimp  Posted	Duplex (.000030 [0.00076] Gold and Tin)
		Tin Plated Steel				Duplex (Gold Flash and Tin)
						Select (.000030 [0.00076] Gold and Gold Flash)

## HDP-20 Crimp Snap-In Contact Connectors (Continued)

### Product Facts

- Shell sizes offer wide choice of contact positions—9, 15, 25, 37 and 50
- Lower cost, commercial version of the military approved series
- Tin or zinc plated shells, with or without grounding indents
- Crimp snap-in contacts allows loading of only the number of contacts being used
- Available with shielding hardware and shielding enclosure kits
- Numerous cable clamps and mating hardware options
- Low cost, high performance, precision-formed crimp contacts

- Machine applied terminations assure highest production rates at lowest applied cost
- Intermateable with any size 20 Subminiature D connector dimensionally complying with MIL-C-24308
- Recognized under the Component Program of Underwriters Laboratories Inc., File No. E28476
- Listed under Underwriters Laboratories Inc., Standard 1863, Communication Circuit Accessories, File No. E81956
- Certified by Canadian Standards Association, File No. LR 1088108 (LR 7189-207)

### Section Contents

Plug and Receptacle Connectors	92, 93
Basic Shielding Hardware Kits	94, 95
Shielding Hardware Enclosure Kits	96, 97
Preassembled Shielded Connector Kits	98
Ferrules for Shielding Hardware Kits	99
Contacts	100, 101
Application Tooling	102

Unshielded Cable Clamps	Shielded Cable Clamps and Shielding Hardware and Enclosure Kits	Mounting and Mating Hardware
<p>One-Piece Cable Clamp 180°/120° Quik-Snap (pg. 134)</p> <p>Box and Lid Straight/90° Exit (pg. 137)</p> <p>Box and Lid with Male Screw Retainers (pg. 137)</p> <p>Clam Shell Straight/45° Exit (pg. 138)</p> <p>Clam Shell Straight/45° Exit with Male Screw Retainers (pg. 138)</p>	<p>Straight Exit RFI/EMI Shields for Jacketed Cable (pgs. 139, 142)</p> <p>90° Exit Die Cast RFI/EMI Shields for Jacketed Cable (pg. 142)</p> <p>Basic Shielding Hardware Kits (pgs. 94, 95)</p> <p>Shielding Hardware Enclosure Kits (pgs. 96, 97)</p>	<p>Keying Plug (pg. 155)</p> <p>Male Screw Retainers (pgs. 146, 147)</p> <p>Female Screwlocks (pg. 148)</p> <p>Locking Posts and Slide Latches (pgs. 149, 151)</p> <p>Spring Latch, Two-Piece (pg. 152)</p> <p>Latching Blocks (pgs. 153, 154)</p> <p>Standoff Bushings (pg. 155)</p>

### Contact Retention Features

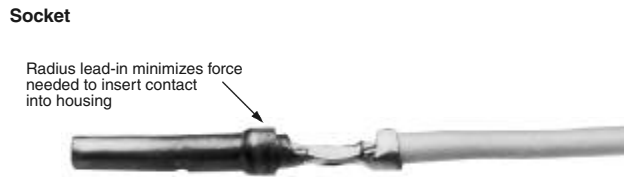
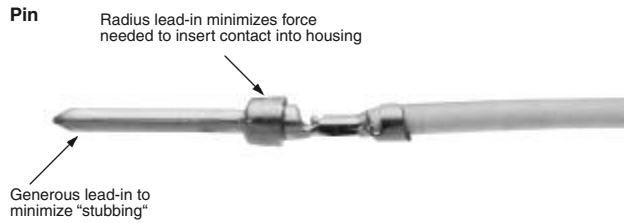

**HDP-20 Crimp Snap-In Contact Connectors** (Continued)



**Plug**

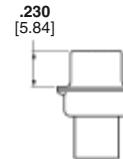

**Material and Finish:**  
**Shell**—Steel, zinc or tin plated  
**Insert**—94V-0 rated thermoplastic, black

**Mounting Holes:**  
**Standard**—.120 [3.05] Dia.  
**Clinch Nut**—4-40 threads with self-locking feature

- Related Product Data:**
- Contact Arrangements**—page 40
  - Performance Characteristics**—page 41
  - Contacts**—pages 100, 101
  - Application Tooling**—page 102
  - Mateable Connectors:**
    - HDE**—pages 110-123
    - HDP**—pages 90-102
    - HD-20 Board Mount**—pages 54-71, 78-85, 87-89
  - Mating/Panel Mounting**—page 42
  - Cable Clamps**—pages 132, 133, 135-137, 140, 141, 144, 145
  - Mating Hardware**—pages 146-150, 153, 155

- Technical Documents:**
- Product Specification**—108-40005
  - Application Specifications**—114-10000, 114-40030

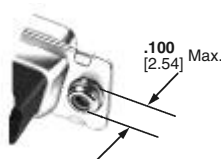

**Clinch Nut**  
(Plug and Receptacle)

**Note:** Instruction Sheets for TE Tooling are packaged with the tooling. For additional information call the Tooling Assistance Center: **1-800-722-1111**.

**HDP-20 Crimp Snap-In Contact Connectors** (Continued)



**Receptacle**

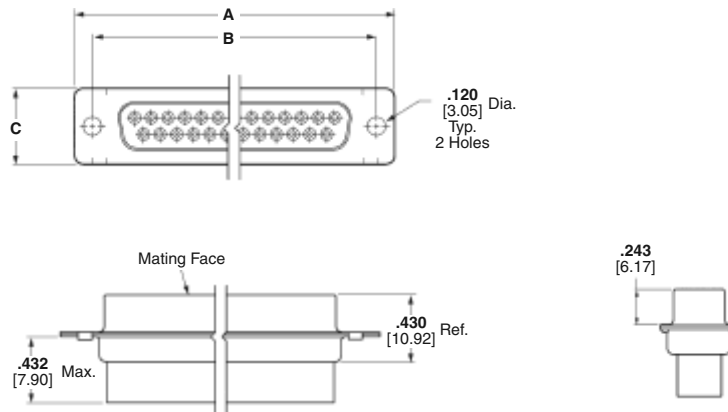

Cable Connectors

Shell Size	No. of Contact Positions	Dimensions			Insert Material	Mounting Method	Plug Part Numbers			Receptacle Part Nos.	
		A	B	C			Zinc Plated Shell	Tin Plated Shell		Zinc Plated Shell	Tin Plated Shell
								Without Grounding Indents	With Grounding Indents		
1	9	1.213 30.81	.984 24.99	.494 12.55	94V-0	Standard	205204-9	205204-8	205204-4	205203-8	205203-3
						Clinch Nut	—	1658642-2	1658642-1	—	1658643-1
2	15	1.541 39.14	1.312 33.33	.494 12.55	94V-0	Standard	205206-9	205206-8	205206-3	205205-7	205205-2
						Clinch Nut	—	—	5745908-2	—	1658644-1
3	25	2.088 53.04	1.852 47.04	.494 12.55	94V-0	Standard	5205208-1	207464-7	207464-2	5205207-1	207463-1
						Clinch Nut	—	—	5745036-2	207516-6	207516-5
4	37	2.729 69.32	2.500 63.50	.494 12.55	94V-0	Standard	205210-8	205210-7	205210-3	205209-7	205209-2
						Clinch Nut	—	—	745135-4	—	5207661-3
5	50	2.635 66.93	2.406 61.11	.605 15.37	94V-0	Standard	1658641-3	1658641-1	1658641-2	1658640-2	1658640-1
						Clinch Nut	—	—	5745883-2	—	5745884-1

**Note:** Plugs accept size 20 DF pin contacts and receptacles accept size 20 DF socket contacts.

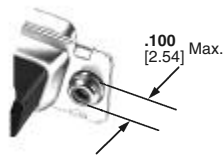

**Clinch Nut**  
(Plug and Receptacle)

**Note:** Instruction Sheets for TE Tooling are packaged with the tooling. For additional information call the Tooling Assistance Center: **1-800-722-1111**.

**Note:** All part numbers are RoHS compliant.

## HDP-20 Basic Shielding Hardware Kits

### Plug



#### Each kit contains:

- Connector
- Inner shield
- Outer shield

Contacts and ferrules must be purchased separately.

#### Material and Finish:

**Connector Shells**—Steel, tin plated

**Connector Insert**—94V-0 rated thermoplastic, black

**Shield**—Steel, tin plated

#### Related Product Data:

**Contact Arrangements**—page 40

**Performance Characteristics**—page 41

**Contacts**—pages 100, 101

**Application Tooling**—page 102

#### Mateable Connectors:

**HDE**—pages 110-123

**HDP**—pages 90-102

**HD-20 Board Mount**—

pages 54-71, 78-85, 87-89

**Mating/Panel Mounting**—page 42

**Mating Hardware**—pages 146-150, 153, 155

**Ferrules**—page 99

#### Technical Documents:

**Product Specifications**—

108-40005

108-40030

**Application Specifications**—

114-10000

114-40030

**Instruction Sheet**—408-9010

**Note:** Instruction Sheets for TE Tooling are packaged with the tooling. For additional information call the Tooling Assistance Center: **1-800-722-1111**.

**HDP-20 Basic Shielding Hardware Kits (Continued)**

**Receptacle**



**Clinch Nut**  
(Plug and Receptacle)



Ferrule (Must Be Purchased Separately)

Shell Size	No. of Contact Positions	Dimensions		Recommended Cable Outer Dia. Range	Max. Inner Cable Bundle Dia.†	Mounting Method	Plug Kit Numbers	Receptacle Kit Numbers
		D	E					
1	9	.700	1.535	.165-.455	.350	Standard	1658645-1	1658646-1
		17.78	38.99			Clinch Nut	5748526-1	5748536-1
2	15	1.024	1.535	.165-.455	.350	Standard	1658647-1	5747539-1
		26.01	38.99			Clinch Nut	5750636-1	5787908-1
3	25	1.576	1.535	.165-.455	.350	Standard	1658648-1	1658649-1
		40.03	38.99			Clinch Nut	—	1658662-1
4	37	2.215	1.892	.338-.562	.450	Standard	1658650-1	1658651-1
		56.26	48.06			Clinch Nut	5786929-1	—
5	50	2.120	1.876	.338-.480	.450	Standard	1658652-1	1658653-1
		53.85	47.65					

**Notes:** 1. Plugs accept size 20 DF pin contacts and receptacles accept size 20 DF socket contacts.  
 2. Components of the kits are shipped unassembled and bulk-packaged in quantities of 100 pieces.  
 †Maximum cable diameter after jacket and braid removed.

**Note:** All part numbers are RoHS compliant.

## HDP-20 Shielding Hardware Enclosure Kits



### Plug

#### Each Kit Contains:

- Connector
- Inner shield
- Outer shield
- Enclosure
- Two jackscrews

Contacts and ferrules must be purchased separately.

#### Material and Finish:

**Connector Shells**—Steel, tin plated.

**Connector Insert**—94V-0 rated thermoplastic, black

**Shield**—Steel, tin plated

**Enclosure**—PVC, black

**Jackscrews**—Zinc alloy

#### Related Product Data:

**Contact Arrangements**—page 40

**Performance Characteristics**—page 41

**Contacts**—pages 100, 101

**Application Tooling**—page 102

#### Mateable Connectors:

**HDE**—pages 110-123

**HDP**—pages 90-102

**HD-20 Board Mount**—pages 54-71, 78-85, 87-89

**Mating/Panel Mounting**—page 42

**Mating Hardware**—pages 146-150, 153, 155

**Ferrules**—page 99

#### Technical Documents:

##### Product Specifications—

108-40005

108-40030

##### Application Specifications—

114-10000

114-40030

##### Instruction Sheet—408-9172

**Note:** Instruction Sheets for TE Tooling are packaged with the tooling. For additional information call the Tooling Assistance Center: **1-800-722-1111**.

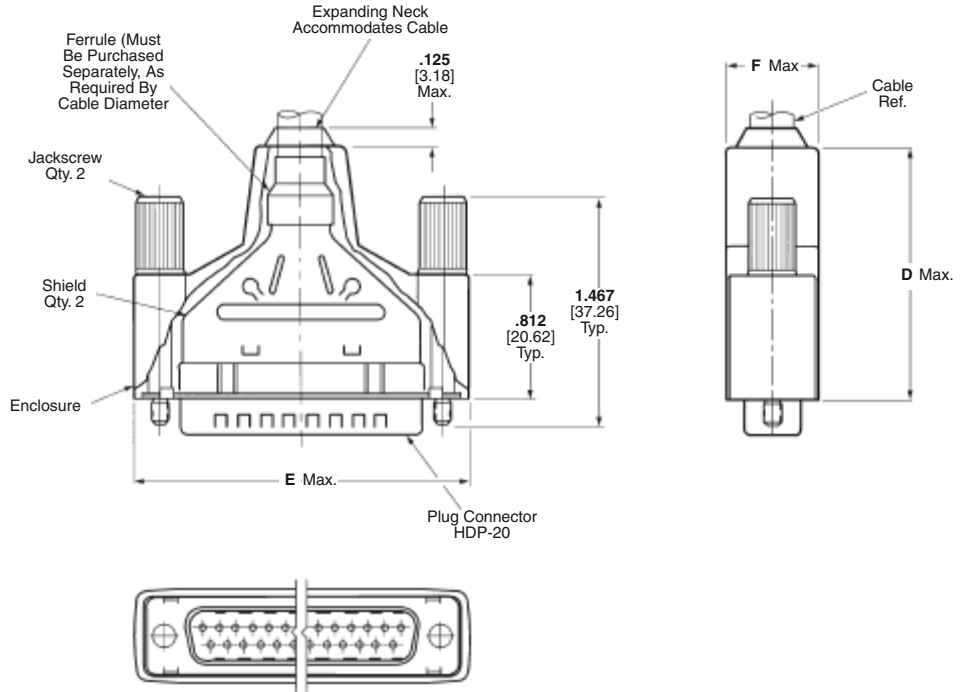

**HDP-20 Shielding Hardware Enclosure Kits** (Continued)

**Receptacle**

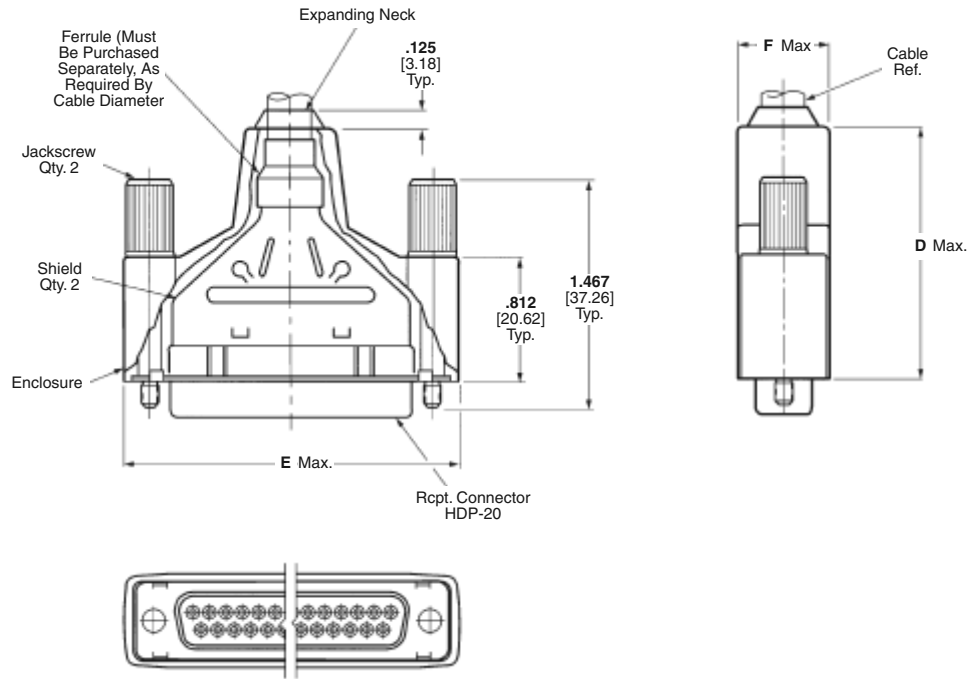

Cable Connectors

Shell Size	No. of Contact Positions	Dimensions			Recommended Cable Outer Diameter Range	Max. Inner Cable Bundle Dia.†	Insert Material	Kit Numbers		Shielding Enclosure Expansion Tool	
		D	E	F				Plug	Receptacle	Cable O.D. (Max.)	Part Number
1	9	1.660	1.355	.630	.190-.330 4.83-8.38	.330 8.38	94V-0	1658655-1	1658654-1	.330 8.38	58241-4
		42.16	34.42	16.00							
2	15	1.660	1.685	.630	.190-.330 4.83-8.38	.330 8.38	94V-0	1658657-1	1658656-1	.450 11.43	58241-1
		42.16	42.80	16.00							
3	25	1.660	2.210	.630	.217-.435 5.51-11.05	.350 8.89	94V-0	1658659-1	1658658-1	.572 14.52	58241-2
		42.16	56.13	16.00							
4	37	2.010	2.865	.730	.338-.562 8.59-14.28	.450 11.43	94V-0	5747958-1	1658660-1	.450 11.43	58241-1
		51.05	72.77	18.54							
5	50	2.010	2.775	.730	.338-.562 8.59-14.28	.450 11.43	94V-0	1658661-1	5747959-1	.450 11.43	58241-1
		51.05	70.49	18.54							

**Notes:** 1. Plugs accept size 20 DF pin contacts and receptacles accept size 20 DF socket contacts.  
 2. Components of the kits are shipped unassembled and bulk-packaged in quantities of 100 pieces.  
 †Maximum cable diameter after jacket and braid removed.

**Note:** All part numbers are RoHS compliant.



## Shielded Connector, Preassembled Kit

Designed to meet the requirements of Local Area Networking, this Subminiature D Shielded Connector Kit is available with slide latches attached to the receptacle. The receptacle is shielded and covered with a durable plastic enclosure. This shielding decreases emissions and provides an effective EMI/RFI barrier.

Preassembled connector kits are available in Subminiature D, shell size 2, 15-position configuration and accept crimp, snap-in HD-20 contacts. Contacts are available separately and allow for selective positioning.

Other sizes and styles can be made available, consult TE.



Receptacle  
Part No. 749246-1

### Material and Finish:

**Inserts**—94V-0 rated nylon, black

**Enclosures**—Elastomer, styrene polyolefin, or PVC, black

**Shields and Shells**—Carbon steel per ASTM A109, plated with .000200 [0.00508] min. tin over .000050 [0.00127] min. copper

**Note:** Instruction Sheets for TE Tooling are packaged with the tooling. For additional information call the Tooling Assistance Center: **1-800-722-1111**.

### Related Product Data:

**Contact Arrangements**—page 40

**Performance Characteristics**—page 41

**Contacts**—pages 100, 101

**Application Tooling**—page 102

**Ferrules**—page 99

### Technical Documents:

**Product Specifications**—108-40005, 108-40030, 108-40032

**Application Specifications**—114-10000 & 114-40030

**Note:** All part numbers are RoHS compliant.

## HDP-20 Ferrules for Shielding Hardware Kits

### Ferrules for Shielding Hardware Kits



Stepped



Straight

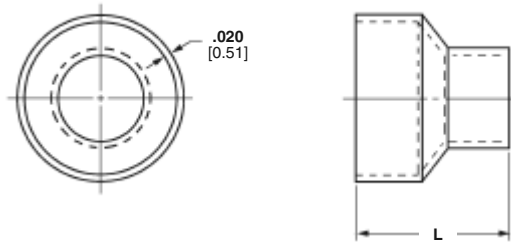

#### Material and Finish:

Steel (annealed), tin plated

#### Related Product Data:

Shielding Hardware and Enclosure Kits—pages 94-98

#### Technical Documents:

##### Instruction Sheets—

408-9507  
408-9508  
408-9243  
408-9242

**Note:** Instruction Sheets for TE Tooling are packaged with the tooling. For additional information call the Tooling Assistance Center: **1-800-722-1111**.

Shell Sizes	Style	L Dim.	Cable Diameter	Part Numbers	
				Ferrule	Die Sets*
1-3	Stepped	.440 11.18	.165-.190 4.19-4.83	3-747579-0	543424-3
1-3	Stepped	.440 11.18	.190-.217 4.83-5.51	3-747579-0	543424-2
1-3	Stepped	.440 11.18	.217-.246 5.51-6.25	3-747579-0	543424-8
1-3	Stepped	.440 11.18	.246-.284 6.25-7.21	3-747579-2	543424-1
1-3	Stepped	.440 11.18	.284-.324 7.21-8.23	3-747579-2	543424-7
1-3	Stepped	.440 11.18	.324-.375 8.23-9.53	3-747579-4	543424-6
1-3	Straight	.440 11.18	.375-.437 9.53-11.10	2-747579-7	543424-5
1-3	Straight	.440 11.18	.400-.460 10.16-11.56	3-747579-6	543424-4
4-5	Stepped	.625 15.88	.230-.265 5.84-6.73	2-747580-4	543425-2
4-5	Stepped	.625 15.88	.338-.385 8.59-9.78	2-747580-3	543425-1
4-5	Stepped	.625 15.88	.375-.432 9.53-10.97	2-747580-1	58238-1
4-5	Stepped	.625 15.88	.422-.490 10.72-12.45	3-747580-1	58237-2
4-5	Straight	.625 15.88	.480-.562 12.19-14.28	2-747580-2	58237-1

\*Die sets used with Hand Crimping Tool Part No. 543344-1 or Pneumatic Bench Tool Part No. 312522-3 equipped with Die Set Holder Part No. 58449-1.

### Application Tooling for Shielding Hardware Kits



Hand Crimping Tool  
No. 543344-1  
(Requires Die Sets, see table above.)



Shielding Enclosure Expansion Tools  
Part No. 58241-1 (.450 [11.43])†  
58241-2 (.572 [14.53])†  
58241-4 (.330 [8.38])†  
†Maximum Cable Diameter (Instruction Sheet—408-9172)

Pneumatic Bench Tool  
No. 312522-3  
(Requires Die Set Holder No. 58449-1.)



**Note:** All part numbers are RoHS compliant.

## HDP-20 Connector Contacts, Precision Formed

### Contact Size 20 DF Pin Diameter .040 [1.02]

#### Material and Finish:

**Pin**—Brass

**Socket**—Phosphor bronze

#### Plated

**A**—Select—Gold flash over nickel on entire contact, with additional .000030 [0.00076] gold on mating end

**B**—Duplex—.000030 [0.00076] gold on mating end, tin on termination end, with entire contact nickel underplated

**C**—Gold flash over nickel on entire contact

**D**—Duplex—Gold flash on mating end, tin on termination end, with entire contact nickel underplated

#### Related Product Data:

**Performance Characteristics**—page 41

**Connectors used with:**  
**HDP**—pages 92-97

**Application Tooling**—page 102

#### Technical Documents:

**Product Specification**—108-40005

**Application Specifications**—114-10000  
114-40030

**Note:** Instruction Sheets for TE Tooling are packaged with the tooling. For additional information call the Tooling Assistance Center: **1-800-722-1111**.

### Crimp Snap-In Contacts

#### With Insulation Support

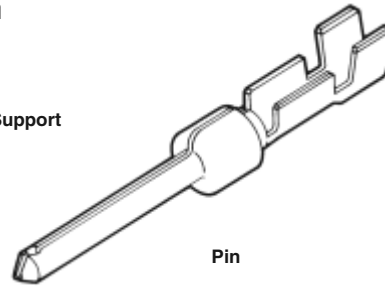

Pin

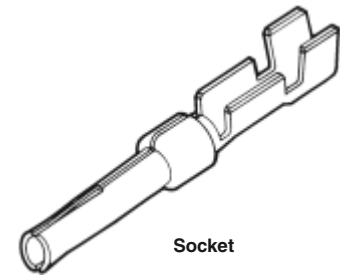

Socket

Wire Size Range AWG [mm <sup>2</sup> ]	Ins. Dia. Max.	Contact Finish (Plating Code)	Contact Part Numbers				Hand Tools for Loose Form Contacts		
			Pin		Socket		PRO-CRIMPER II Hand Tool	CERTI-CRIMP II Hand Tool (Color Code)	Applicators* for Strip Form Contacts
			Strip Form	Loose Form	Strip Form	Loose Form			
28-24 0.08-0.2	.040 1.02	A	66507-3	66507-9	66505-3	66505-9	58448-2	91503-1 (Blue Dot)	466423-4** 466901-1***
		B	1658540-4	1658540-5	1658538-2	—			
		C	66507-4	1-66507-0	66505-4	1-66505-0			
		D	1658540-1	1658540-2	1658538-3	1658538-1			
26-22 0.15-0.4	.040 1.27	A	66682-2	66682-4	66683-2	66683-4	—	91549-1 (Black Dot)	466963-1***
		B	5066682-9	—	1-5066683-0	—			
		C	745254-3	745254-7	745253-3	745253-7			
		D	1658544-3	—	1658543-3	—			
24-20 0.2-0.6	.060 1.52	A	66506-3	66506-9	66504-3	66504-9	58448-2	91503-1 (Red Dot)	466422-4** 466900-1***
		B	1658539-1	1658539-3	1658537-3	1658537-4			
		C	66506-4	1-66506-0	66504-4	1-66504-0			
		D	1658539-2	1658539-4	1658537-1	1658537-2			

\*For Part Nos. of Special Applicators and Applicators for other model machines, call the TE Tooling Assistance Center at **1-800-722-1111**.

\*\*For use with AMP-O-ELECTRIC Model "G" Terminating Machine.

\*\*\*For use with AMP-O-MATIC Model II Stripper-Crimper Machine.

#### Without Insulation Support

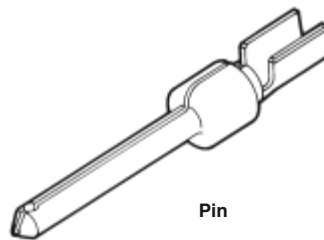

Pin

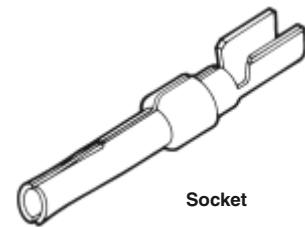

Socket

Wire Size Range AWG [mm <sup>2</sup> ]	Ins. Dia. Max.	Contact Finish (Plating Code)	Contact Part Numbers		Hand Tools for Loose Form Contacts	
			Pin	Socket	CERTI-CRIMP II Hand Tool (Color Code)	Applicators* for Strip Form Contacts
			Strip Form	Strip Form		
28-24 0.08-0.2	.068 1.73	A	205310-2	205311-3	91548-1 (Blue Dot)	466903-1***
		C	205202-6	205201-6		
24-20 0.2-0.6	.068 1.73	A	205202-2	205201-3	91548-1 (Red Dot)	466902-1***
		C	205202-6	205201-6		
22-18 0.4-0.8	.068 1.73	A	745229-2	745230-2	91513-1 (Green Dot)	466996-1***
		B	1658541-1	1658542-2		
		C	745229-5	745230-5		
		D	—	1658542-1		

**Note:** Wire insulation diameter is limited by the connector housing cavity and clearance for the insertion/extraction tool.

\*For Part Nos. of Special Applicators and Applicators for other model machines, call the TE Tooling Assistance Center at **1-800-722-1111**.

\*\*\*For use with AMP-O-MATIC Model II Stripper-Crimper Machine.

**Note:** All part numbers are RoHS compliant.

**HDP-20 Connector Contacts, Precision Formed** (Continued)

**Contact Size 20 DF  
Pin Diameter .040 [1.02]**

**Material and Finish:**

**Pin**—Brass

**Socket**—Phosphor bronze

**Plated:**

**A**—Duplex plated .000030 [0.00076] gold on mating end, with entire contact .000050 [0.00127] min. nickel under-plated

**B**—Duplex plated gold flash on mating end, with entire contact .000050 [0.00127] min. nickel underplated

**Related Product Data:**

**Performance Characteristics**—  
page 41

**Connectors used with:**  
HDP—pages 92, 93

**Technical Documents:**

**Product Specification**—108-40005

**Application Specifications**—  
114-10000  
114-40030

**Note:** Instruction Sheets for TE Tooling are packaged with the tooling. For additional information call the Tooling Assistance Center: **1-800-722-1111**.

**Contact Size 20 DF  
Pin Diameter .040 [1.02]**

**Material and Finish:**

**Pin**—Brass

**Socket**—Phosphor bronze

**Plated**—Gold flash over nickel on entire contact, with additional .000030 [0.00076] gold on mating end

**Related Product Data:**

**Performance Characteristics**—  
page 41

**Connectors used with:**  
HDP—pages 92-97

**Technical Documents:**

**Product Specification**—108-40005

**Application Specification**—  
114-40030

**Insertion/Extraction Tool  
No. 91285-1**

This tool includes interchangeable tips to Insert/Extract:

Size 22, 28-22 AWG [0.08-0.4 mm<sup>2</sup>]

Size 20, Posted Contacts

(Instruction Sheet—408-9404)

**.025 [0.64]  
Square Posted Contacts**

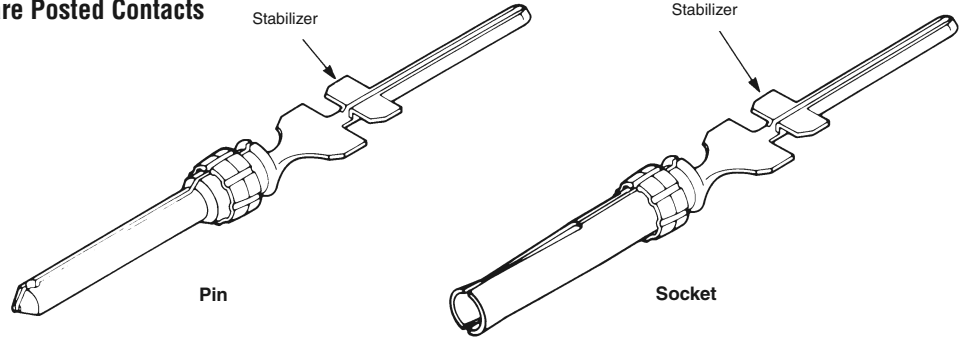

Contact Finish (Plating Code)	Loose Form Contact Numbers							
	.125 [3.18] Post Length*		.188 [4.78] Post Length*		.427 [10.85] Post Length*		.651 [16.54] Post Length*	
	Pin	Socket	Pin	Socket	Pin	Socket	Pin	Socket
A	—	5-745288-5	5-745287-4	7-745288-0	4-745287-7	5-745288-8	5-745287-0	6-745288-1
B	—	—	—	—	—	7-745288-2	—	7-745288-2

\*Length of post extending from rear of HDP-20 metal-shell connector.

**Solder Cup Contacts,  
Snap-In**



**18 AWG Max. Wire (.046 [1.17] Max. Conductor Diameter)**

Strip Form Contact Number		Loose Form Contact Number	
Pin	Socket	Pin	Socket
66570-2	66569-2	66570-3	66569-3



**Note:** Contacts to be soldered to wire before being inserted into housing

**Note:** All part numbers are RoHS compliant.

## HDP-20 Application Tooling

HDP-20 contacts may be applied by a variety of hand tools and machines. For low production runs, repairs and prototype work, we offer either our premium CERTI-CRIMP Hand Tool or our commercial PRO-CRIMPER II Hand Tool. For medium-volume production, you have the choice of our AMP-O-ELECTRIC Model "G" Terminating Machine, our new Model "M" Terminating Machine, or our AMP-O-MATIC Model II Stripper-Crimper Machine. The Stripper-Crimper is typically used for terminating the wires of jacketed cable. All three machines can be bench mounted.

For production requirements ranging from non-stop high volumes to countless series of short runs, our popular AMPOMATOR CLS IV+ fully-automated lead-making machine is an ideal choice.

For further information about these or other TE hand tools and machines, call the TE Tooling Assistance Center at **1-800-722-1111**.



### AMPOMATOR CLS IV+ Lead-Making Machine

This versatile machine now incorporates two AMP-O-ELECTRIC Model "G" Terminating Units. Basically, it produces single-wire leads in lengths from 1.62 [41.2] to 1000 [25 400]. It measures, cuts, strips and terminates wire sizes from 26 to 10 AWG [0.12 to 6 mm<sup>2</sup>] stranded and 26 to 16 AWG [0.12 to 1.4 mm<sup>2</sup>] solid. Production rates range up to 4800 leads per hour for 3 [76.2] lengths.

The machine is microprocessor controlled, and programmed and operated with

an easy-to-follow, menu-driven touchscreen. It can retain data for up to 200 lead assemblies. Off-line programming is also possible with optional software OffLine-Plus for Windows 95, **Part No. 189263-2**.

Air requirement is 90 psi [6.21] bar minimum at 15 scfm [0.0071 m<sup>3</sup>/s]. Power requirement is single-phase 220 VAC, 50 or 60 Hz, 25 A.

For further information request Catalog 124324.

**Note:** All part numbers are RoHS compliant.

## HDP-22 Crimp Snap-In Contact Connectors



### Product Selection Guide

Connector			
Type	Insert Material	Shell Type Material and Finish	Mounting
Plug (pg. 105)	94V-0 Rated Thermoplastic, Black	Tin Plated Steel with Grounding Indents	.120 [3.05] Dia. Holes

Contacts		
Type	Termination	Plating
Pin (pg. 109)	Crimp	Duplex (.000030 [0.00076] Gold and Tin)  Duplex (Gold Flash and Tin)

Receptacle (pg. 105)	94V-0 Rated Thermoplastic, Black	Tin Plated Steel	.120 [3.05] Dia. Holes
-------------------------	----------------------------------	------------------	------------------------------

Socket (pg. 109)	Crimp	Duplex (0.000030 [0.00076] Gold and Tin)  Duplex (Gold Flash and Tin)
---------------------	-------	--

**HDP-22 Crimp Snap-In Contact Connectors** (Continued)

**Product Facts:**

- Approximately 65% higher density than HD-20 connectors
- Lower cost, commercial version of the military approved Series 90 family
- Available with shielding overmold hardware and shielding enclosure kits
- Capable of using numerous standard HD-20 cable clamps and mating hardware

- Low cost, high performance, precision-formed crimp contacts
- Intermateable with any size 22 Subminiature D connector dimensionally complying with MIL-C-24308
- Recognized under the Component Program of Underwriters Laboratories Inc., File No. E28476
- Listed under Underwriters Laboratories Inc., Standard 1863, Communication Circuit Accessories, File No. E81956
- Certified by Canadian Standards Association, File No. LR 1088108 (LR 7189-207)

**Section Contents**

Plug and Receptacle Connectors ..... 105  
 Basic Shielding Hardware Kits ..... 106  
 Shielding Hardware Enclosure Kits ..... 107  
 Ferrules for Shielding Hardware Kits ..... 108  
 Contacts ..... 109  
 Application Tooling ..... 108, 109

Unshielded Cable Clamps	Shielded Cable Clamps and Shielding Hardware and Enclosure Kits	Mounting and Mating Hardware
One-Piece All Plastic Cable Clamp 180°/120° (Quik-Snap) (pg. 133)	Straight Exit RFI/EMI Shields for Jacketed Cable (pg. 141)	Male Screw Retainers (pgs. 146, 147)
Box and Lid Straight/90° Exit (pg. 137)	90° Exit RFI/EMI Die Cast Shields For Jacketed Cable (pg. 142)	Female Screwlocks (pg. 148)
Box and Lid Straight/90° Exit with Male Screw Retainers (pg. 137)	Basic Shielding Hardware Kits (pg. 106)	Locking Posts and Slide Latches (pgs. 149, 151)
Clam Shell Straight/45° Exit (pg. 138)	Shielding Hardware Enclosure Kits (pg. 107)	Two-Piece Spring Latch (pg. 152)
Clam Shell Straight/45° Exit with Screw Retainers (pg. 138)	Crimp & Split Ring Ferrules (pgs. 143-145)	Latching Blocks (pgs. 153, 154)

**Contact Retention Features**



### HDP-22 Crimp Snap-In Contact Connectors (Continued)



**Plug**  
(With Grounding Indents)



**Receptacle**

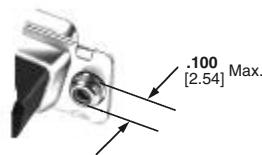

**Clinch Nut**  
(Plug and Receptacle)

**Material and Finish:**

**Shell**—Steel, tin plated  
**Insert**—94V-0 rated thermoplastic, black  
 Contacts and ferrules must be purchased separately.

**Related Product Data:**

- Contact Arrangements**—page 40
- Performance Characteristics**—page 41
- Contacts**—page 109
- Ferrules**—page 108
- Mating/Panel Mounting**—page 42
- Cable Clamps**—pages 132, 133, 135-137, 140, 141, 144, 145
- Mating Hardware**—pages 146-150, 153, 155

**Technical Documents:**

- Application Specification**—114-10001
  - Product Specification**—108-1268
  - Instruction Sheets**—408-9381
- Note:** Instruction Sheets for TE Tooling are packaged with the tooling. For additional information call the Tooling Assistance Center: **1-800-722-1111**.

**Plug**

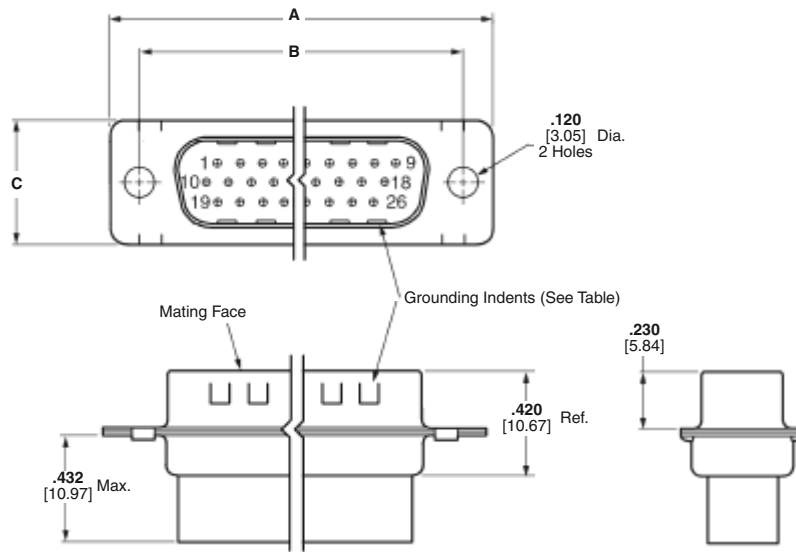

**Receptacle**

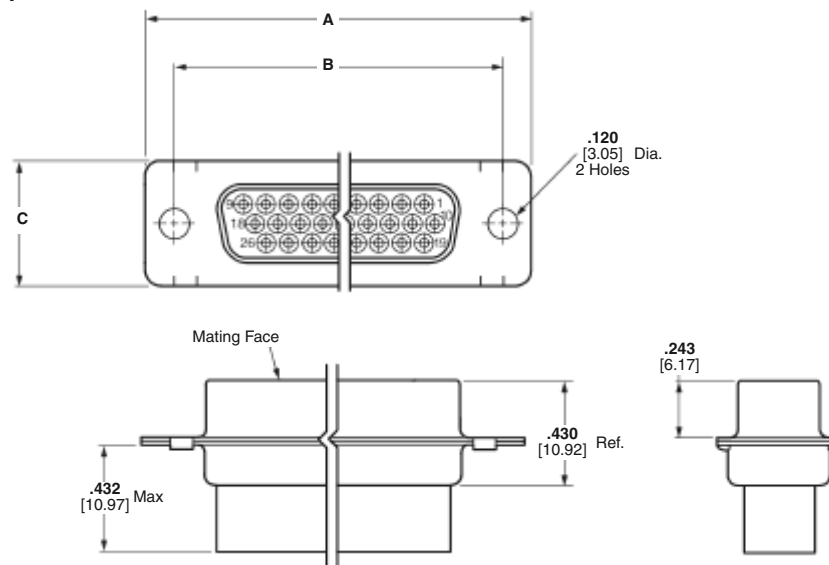

Shell Size	No. of Contact Positions	Dimensions			Part Numbers			
		A	B	C	With Grounding Indents	With Clinch Nuts		
					Plug	Plug	Receptacle	With Clinch Nuts Receptacle
1	15	1.213 30.81	.984 24.99	.494 12.55	748364-1	1658691-1	1658681-1	1658690-1
2	26	1.541 39.14	1.312 33.33	.494 12.55	1658671-1	5749717-1	1658682-1	5788816-1
3	44	2.088 53.84	1.852 47.04	.494 12.55	1658672-1	—	1658683-1	5786583-1
4	62	2.729 69.32	2.500 63.50	.494 12.55	1658673-1	6658293-1	1658684-1	—
5	78	2.635 66.93	2.406 61.11	.605 15.37	1658674-1	—	1658685-1	5788817-1

**Note:** Plugs accept size 22 DF pin contacts and receptacles accept size 22 DF socket contacts.

**Note:** All part numbers are RoHS compliant.



## HDP-22 Crimp Snap-In Contact Connectors (Continued)

### Basic Shielding Hardware Kits



Plug



Receptacle

#### Each kit contains:

- Connector
- Inner shield
- Outer shield

Contacts and ferrules must be purchased separately.

#### Material and Finish:

- Connector Shell**—Steel, tin plated
- Connector Insert**—94V-0 rated thermoplastic, black
- Shields**—Steel, tin plated

#### Related Product Data:

- Contact Arrangements**—page 40
- Performance Characteristics**—page 41
- Contacts**—page 109
- Ferrules**—page 108
- Application Tooling**—pages 108 & 109

#### Mateable Connectors—

- pages 105 & 107
- Mating Hardware**—pages 146-150, 153, 155
- Mating/Panel Mounting**—page 42

#### Technical Documents:

- Application Specifications**—114-10001
- Product Specification**—108-1268
- Instruction Sheet**—408-9381, 408-9010

**Note:** Instruction Sheets for TE Tooling are packaged with the tooling. For additional information call the Tooling Assistance Center: **1-800-722-1111**.

### Plug

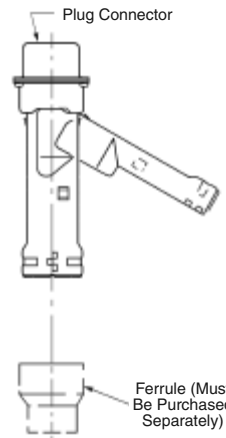
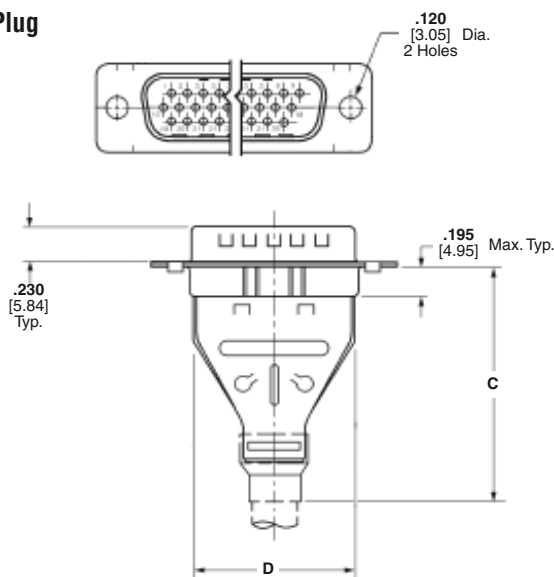

### Receptacle

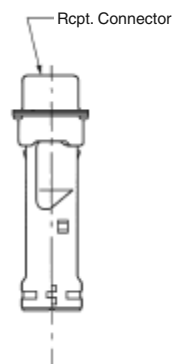
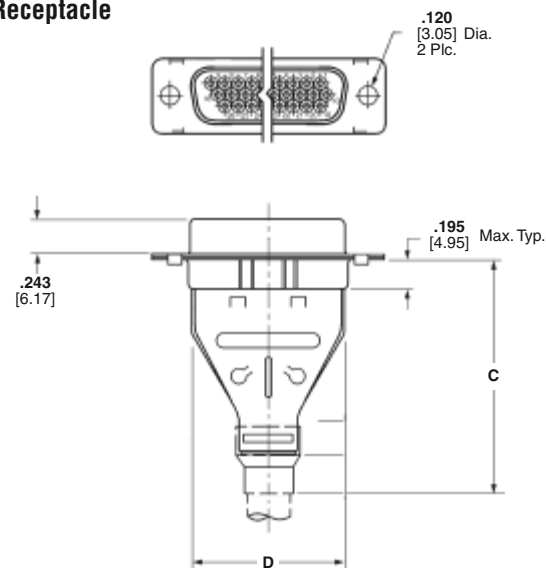

Shell Size	No. of Contact Positions	Dimensions		Recommended Cable Outer Dia. Range	Max. Inner Cable Bundle Dia.†	Kit Numbers	
		C	D			Plug	Receptacle
1	15	1.535 38.99	.700 17.78	.165-.455 4.19-11.56	.350 8.89	1658675-1	5748634-1
2	26	1.535 38.99	1.024 26.01	.165-.455 4.19-11.56	.350 8.89	1658676-1	1658687-1
3	44	1.535 38.99	1.576 40.03	.165-.455 4.19-11.56	.350 8.89	1658677-1	5748636-1
4	62	1.892 48.06	2.215 56.26	.338-.562 8.59-14.28	.450 11.43	5748471-1	—
5	78	1.876 47.65	2.120 53.85	.338-.490 8.59-12.45	.450 11.43	5748472-1	—

**Notes:** 1. Plugs accept size 22 DF pin contacts and receptacles accept size 22 DF socket contacts.  
2. Components of the kits are shipped unassembled and bulk-packaged in quantities of 100 pieces.  
†Maximum cable diameter after jacket and braid removed.

**Note:** All part numbers are RoHS compliant.

## HDP-22 Crimp Snap-In Contact Connectors (Continued)

### Shielding Hardware Enclosure Kits



Plug



Receptacle

#### Each kit contains:

- Connector
- Inner shield
- Outer shield
- Enclosure
- Two jackscrews

Contacts and ferrules must be purchased separately.

#### Material and Finish:

- Connector Shell**—Steel, tin plated
- Connector Insert**—94V-0 rated thermoplastic, black
- Shields**—Steel, tin plated
- Enclosure**—PVC, black
- Jackscrews**—Zinc alloy

#### Related Product Data:

- Contact Arrangements**—page 40
- Performance Characteristics**—page 41
- Contacts**—page 109
- Ferrules**—page 108

**Application Tooling**—pages 108 & 109

**Mateable Connectors**—pages 105 & 106

**Mating Hardware**—pages 146-150, 153-155

**Mating/Panel Mounting**—page 42

#### Technical Documents:

- Application Specifications**—114-10001
- Product Specification**—108-1268
- Instruction Sheet**—408-9381  
408-9172

**Note:** Instruction Sheets for TE Tooling are packaged with the tooling. For additional information call the Tooling Assistance Center: **1-800-722-1111**.

### Plug

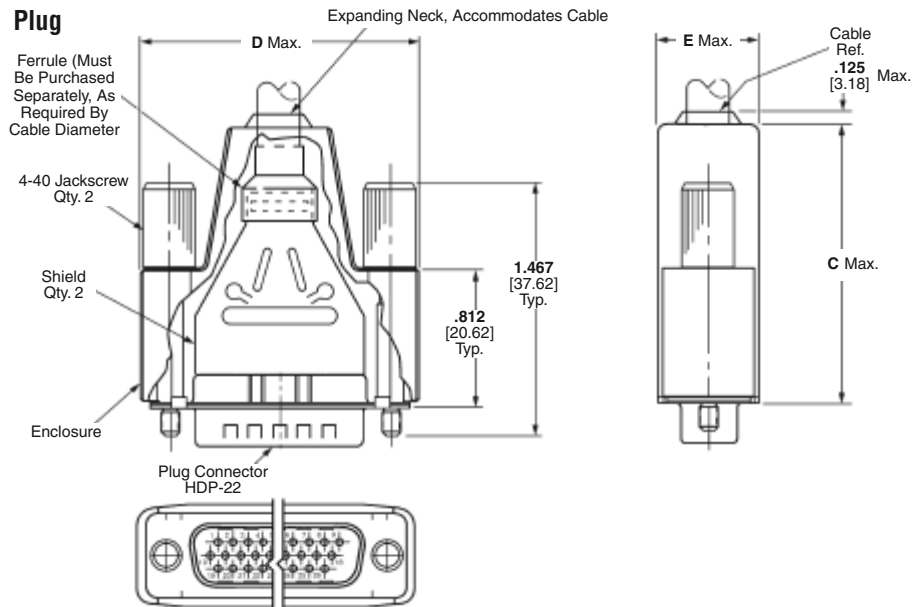

### Receptacle

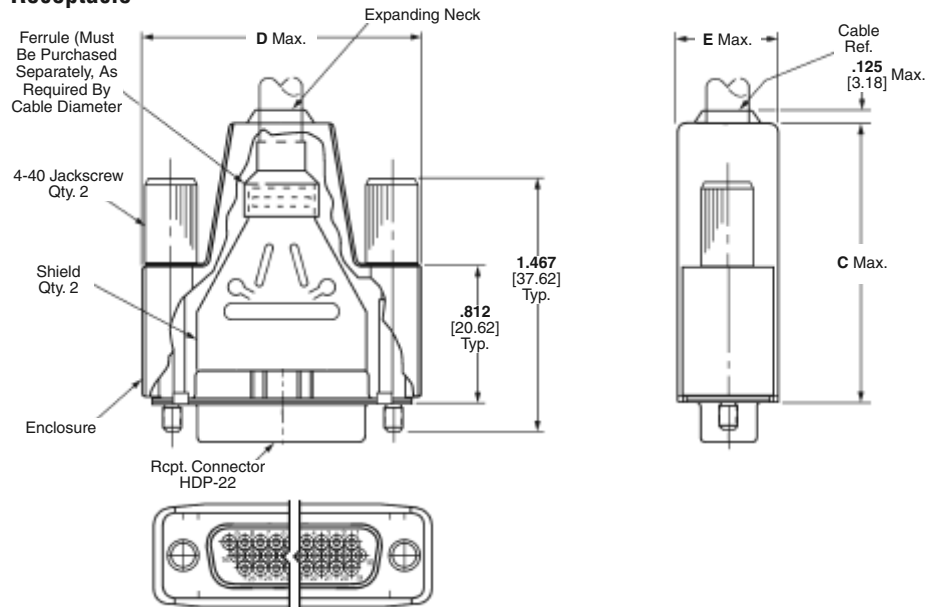

Shell Size	No. of Contact Positions	Dimensions			Recommended Cable Outer Diameter	Max. Inner Cable Bundle Dia.†	Kit Numbers		Shielding Enclosure Expansion Tool	
		C	D	E			Plug	Receptacle	Cable O.D. (Max.)	Part Number
1	15	1.640 41.66	1.355 34.42	.630 16.00	.190-.330 4.83-8.38	.330 8.38	1658678-1	1658688-1	.330 8.38	58241-4
2	26	1.640 41.66	1.685 42.80	.630 16.00	.190-.330 4.83-8.38	.330 8.38	1658679-1	1658689-1		
3	44	1.640 41.66	2.205 56.01	.630 16.00	.217-.435 5.51-11.05	.350 8.89	1658680-1	5748641-1	.450 11.43	58241-1
4	62	2.010 51.05	2.860 72.64	.730 18.54	.338-.562 8.59-14.28	.450 11.43	5748476-1	5748642-1	.572 14.52	58241-2
5	78	2.010 51.05	2.770 70.36	.730 18.54	.338-.490 8.59-12.45	.450 11.43	5748477-1	—		

**Notes:** 1. Plugs accept size 22 DF pin contacts and receptacles accept size 22 DF socket contacts.  
2. Components of the kits are shipped unassembled and bulk-packaged in quantities of 100 pieces.

†Maximum cable diameter after jacket and braid removed.

**Note:** All part numbers are RoHS compliant.

**HDP-22 Crimp Snap-In Contact Connectors** (Continued)

**Ferrules for Shielding Hardware Kits**

Stepped



Straight

**Material and Finish:**

Steel (annealed), tin plated

**Related Product Data:**
**Shielding Hardware and Enclosure Kits**—pages 106 & 107

**Technical Documents:**
**Instruction Sheets**—

 408-9507  
 408-9508  
 408-9243  
 408-9242

**Note:** Instruction Sheets for TE Tooling are packaged with the tooling. For additional information call the Tooling Assistance Center: **1-800-722-1111**.

Shell Sizes	Style	L Dim.	Cable Diameter	Part Numbers	
				Ferrule	Die Sets*
1-3	Stepped	.440 11.18	.165-.190 4.19-4.83	3-747579-0	543424-3
1-3	Stepped	.440 11.18	.190-.217 4.83-5.51	3-747579-0	543424-2
1-3	Stepped	.440 11.18	.217-.246 5.51-6.25	3-747579-0	543424-8
1-3	Stepped	.440 11.18	.246-.284 6.25-7.21	3-747579-2	543424-1
1-3	Stepped	.440 11.18	.284-.324 7.21-8.23	3-747579-2	543424-7
1-3	Stepped	.440 11.18	.324-.375 8.23-9.53	3-747579-4	543424-6
1-3	Straight	.440 11.18	.375-.437 9.53-11.05	7-747579-7	543424-5
1-3	Straight	.440 11.18	.400-.460 10.16-11.56	3-747579-6	543424-4
4-5	Stepped	.625 15.88	.230-.265 5.84-6.73	2-747580-4	543425-2
4-5	Stepped	.625 15.88	.338-.385 8.59-9.78	2-747580-3	543425-1
4-5	Stepped	.625 15.88	.375-.432 9.53-10.97	2-747580-1	58238-1
4-5	Stepped	.625 15.88	.422-.490 10.72-12.45	3-747580-1	58237-2
4	Straight	.625 15.88	.480-.562 12.19-14.28	2-747580-2	58237-1

\*Die sets used with Hand Crimping Tool Part No. 543344-1 or Pneumatic Bench Tool Part No. 312522-3 equipped with Die Set Holder Part No. 58449-1.

**Application Tooling for Shielding Hardware Kits**

**Hand Crimping Tool**  
 No. 543344-1  
 (Requires Die Sets, see table above.)

**Shielding Enclosure Expansion Tools**  
 Part No. 58241-1 (.450 [11.43])†  
 58241-2 (.572 [14.53])†  
 58241-4 (.330 [8.38])†  
 †Maximum Cable Diameter  
 (Instruction Sheet—408-9507)

**Pneumatic Bench Tool**  
 No. 312522-3  
 (Requires Die Set Holder No. 58449-1.)

**Note:** All part numbers are RoHS compliant.

## HDP-22 Crimp Snap-In Contact Connectors (Continued)

### Material

**Pin**—Brass

**Socket**—Phosphor bronze

### Finish

**A**—Duplex plated .000030 [0.00076] gold on mating end, tin on crimp barrel, with entire contact nickel underplated

**B**—Duplex plated gold flash on mating end, tin on crimp barrel, entire contact nickel underplated

### Related Product Data:

**Performance Characteristics**—page 41

**Connectors used with**—pages 105-107

### Technical Documents:

**Application Specification**—114-10001

**Product Specification**—108-1268

**Instruction Sheet**—408-9381

**Note:** Instruction Sheets for TE Tooling are packaged with the tooling. For additional information call the Tooling Assistance Center: **1-800-722-1111**.

### Precision Formed Crimp Snap-In Contacts, Size 22 DF



Pin



Socket

Wire Size AWG mm <sup>2</sup>	Insulation Diameter Max.	Contact Finish (Plating Code)	Contact Part Numbers				Hand Tools for Loose Form Contacts	
			Pin		Socket		PRO-CRIMPER II Hand Tool	CERTI-CRIMP II Hand Tool
			Strip Form	Loose Form	Strip Form	Loose Form		
28-22 0.4-0.08	.040 1.02	A	1658670-1	1658670-2	1658686-1	1658686-2	90800-1	91520-1
		B	1658670-3	1658670-4	1658686-3	1658686-4		

**Notes:** 1. Strip form contacts shipped 20,000 pieces/reel.

### Insertion/Extraction Tool No. 91285-1 (Instruction Sheet—408-9404)

This tool contains interchangeable tips to Insert/Extract Size 22, 28-22 AWG [0.08-0.4 mm<sup>2</sup>] Crimp Contacts Size 20, 28-20 AWG [0.08-0.4 mm<sup>2</sup>] Crimp Contacts Size 20, Posted Contacts

### Application Tooling



#### Applicators

To accommodate the broad range of wire termination products that TE produces, most TE terminating machines are designed for use with interchangeable applicators. The basic styles are quickly interchangeable to minimize costly down times, and feature dial-in wire and insulation crimp-height settings. Special applicators are now available for use with the AMP Crimp Quality Monitor, for measuring the crimp height of each termination as it is made, plus evaluating the quality of each crimp.

For further information, request Catalog 65404.

For applicator part numbers, call the TE Tooling Assistance Center at **1-800-722-1111**.



#### AMP-O-LECTRIC MODEL "G" Terminating Machine

A totally new design of our most popular machine for bench-top operation. It features a quiet and highly-reliable direct motor drive, electronic controls for ease of setup and operation, and improved guarding and lighting for operator convenience and safety. All versions also include either manual or automatic precision adjustment for crimp height. Power requirement is 120 or 220 VAC, 50 or 60 Hz.

For further information, request Catalog 65828.



#### AMP-O-MATIC Model II Stripper-Crimper Machine

This machine automatically strips as well as terminates individual wires. Similar to the AMP-O-LECTRIC Model "G" machine, applicators are quickly interchangeable, and it includes precision adjustment for crimp height. All adjustments can be made from the front of the machine without special tools. Power requirement is 120 VAC. Air requirement is 80-100 psi [5.52-6.89 bar], 3.5 scfm [0.00165 m<sup>3</sup>/s].

For further information request Catalog 65004.



#### PRO-CRIMPER II Hand Tool Part No. 90800-1

Features interchangeable die sets and ratchet control that provides full die closure to help eliminate partial crimps. The new design is more durable, and requires dramatically less hand force.

For further information, request Catalog 82276.

**Note:** All part numbers are RoHS compliant.

## HDE-20 IDC Connectors for Discrete Wire and Jacketed Cable



### Product Selection Guide

Connector				Contacts Pre-Loaded*		
Type	Insert Material	Shell Type Material and Finish	Mounting	Type	Termination	Plating
<b>Plug</b>						
All-Plastic (pg. 112)	94V-0 Rated Thermoplastic, Black	Tin Plated Steel	.120 [3.05] Dia. Holes	Pins	Insulation Displacement  * Interchangeable crimp snap-in contacts available, see page 121	Duplex (.000030 [0.00076] Gold and Tin)
Metal-Shell (pg. 114)						Duplex (Gold Flash and Tin)
<b>Receptacle</b>						
All-Plastic (pg. 113)	94V-0 Rated Thermoplastic, Black	Tin Plated Steel	.120 [3.05] Dia. Holes	Sockets	Insulation Displacement  * Interchangeable crimp snap-in contacts available, see page 121	Duplex (.000030 [0.00076] Gold and Tin)
Metal-Shell (pg. 115)						Duplex (Gold Flash and Tin)

**HDE-20 IDC Connectors for Discrete Wire and Jacketed Cable** (Continued)

**Product Facts**

- Insulation displacement contacts preloaded in housings
- No wire stripping
- Post plated contacts with no bare edges
- Duplex plated contacts—gold on mating end and tin on crimp end
- Patented contact ensures reliable termination of a wide range of wire sizes and insulation diameters
- Removable contacts for replacement and repair

- Selective loading of contacts available
- Crimp snap-in contacts available for making jumpers between circuits
- Recognized under the Component Program of Underwriters Laboratories Inc., File No. E28476 
- Listed under Underwriters Laboratories Inc., Standard 1863, Communication Circuit Accessories, File No. E81956 
- Certified by Canadian Standards Association, File No. 1088108 (LR 7189-207) 

**Section Contents**

All-Plastic Plug and Receptacle Connectors ..... 112, 113  
 Metal-Shell Plug and Receptacle Connectors ..... 114, 115  
 Basic Shielding Hardware Kits ..... 116, 117  
 Shielding Hardware Enclosure Kits ..... 118, 119  
 Ferrules for Shielding Hardware Kits ..... 120  
 Interchangeable Contacts, Crimp Snap-In ..... 121  
 Application Tooling ..... 122, 123

**Typical Application Rates**

Tool	Rate
Pistol Style	7.4 Sec./Line
Arbor Tool	5.0 Sec./Line
CHAMPOMATOR Machine	2.8 Sec./Line

**Note:** Rates are based on total time to complete a double ended 25 position Jacketed Cable Assembly

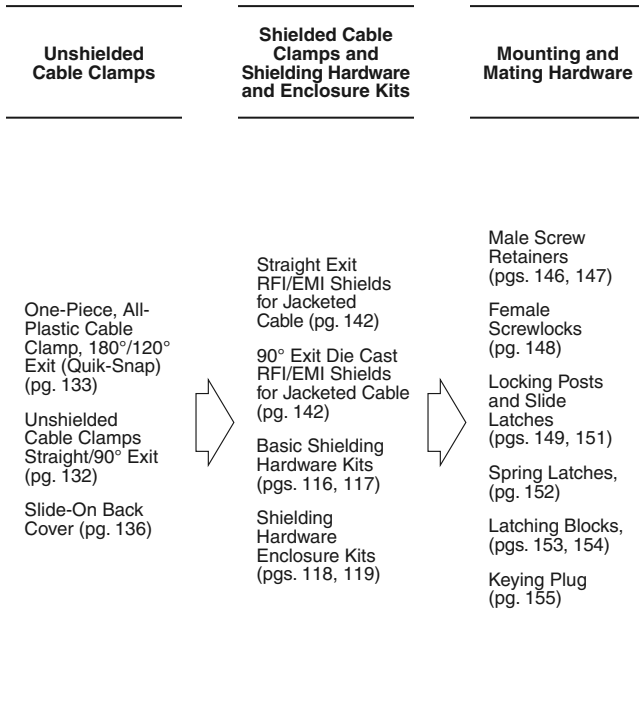

## HDE-20 All-Plastic IDC Connectors

### Plug



Plug

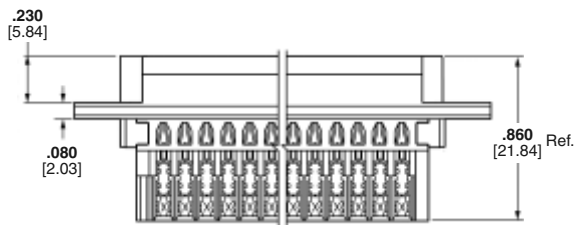
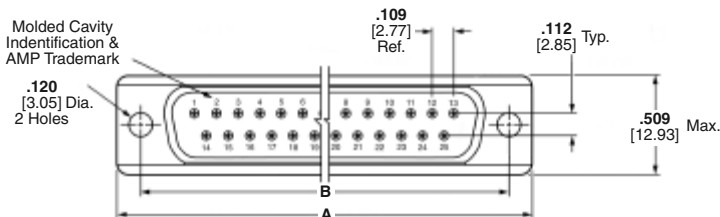

### Material and Finish:

**Housing**—94V-0 rated thermoplastic, black

**Contacts**—Phosphor bronze

**Contact Finish**—Duplex plated:

**A**—.000030 [0.00076] gold on mating end, tin on termination end, with entire contact nickel underplated

**B**—Gold flash on mating end, tin on termination end, with entire contact nickel underplated

### Related Product Data:

**Contact Arrangements**—page 40

**Performance Characteristics**—page 41

**Interchangeable Crimp Snap-In Contacts**—page 121

**Application Tooling**—pages 121-123

### Mateable Connectors:

**HDP**—pages 90-97

**HD-20 Board Mount**—pages 54-71, 78-85, 87-89

**Mating/Panel Mounting**—page 42

**Cable Clamps**—pages 132, 133, 135-137, 139, 140, 144, 145

**Mating Hardware**—pages 146-150, 153, 155

### Technical Documents:

**Product Specification**—108-40011

**Application Specifications**—114-40002  
114-40003

**Instruction Sheet**—408-6621

**Note:** Instruction Sheets for TE Tooling are packaged with the tooling. For additional information call the Tooling Assistance Center: **1-800-722-1111**.

Shell Size	No. of Contact Positions	Dimensions		Contact Finish (Plating Code)	Connector Part Numbers	
		A	B		Contact Identification No. 1 for 30-26 AWG [0.05-0.15mm <sup>2</sup> ] Wire Plug	Contact Identification No. 2 for 26-22 AWG [0.15-0.4mm <sup>2</sup> ] Wire Plug
1	9	1.213 30.81	.984 24.99	A	—	745203-2
				B	—	1-745203-1
2	15	1.541 39.14	1.312 33.33	A	—	745207-7
				B	—	—
3	25	2.090 53.09	1.852 47.04	A	745211-9	745211-7
				B	—	745211-8
4	37	2.732 69.39	2.500 63.50	A	—	745215-7
				B	—	—

- Notes:**
- All connectors are preloaded with insulation displacement contacts. Pins in plug connectors and sockets in receptacle connectors. Contacts accept a max. wire insulation thickness of .015 [0.38] and a max. wire insulation dia. of .060 [1.52].
  - HDE connectors are designed for terminating solid or stranded (7-strand max.) wire.
  - Individual conductor strands should be larger than .005 inch [0.127] diameter.
  - Extraction Tool Part No. 91232-1 (Instruction Sheet 408-6631) is used to remove pin or socket contacts.
  - For terminating more than one wire, or a drain wire, use crimp contacts on page 121.

**Note:** All part numbers are RoHS compliant.

## HDE-20 All-Plastic IDC Connectors (Continued)

### Receptacle



Receptacle



#### Material and Finish:

**Housing**—94V-0 rated thermoplastic, black

**Contacts**—Phosphor bronze

**Contact Finish**—Duplex plated:

**A**— $.000030$  [0.00076] gold on mating end, tin on termination end, with entire contact nickel underplated

**B**—Gold flash on mating end, tin on termination end, with entire contact nickel underplated

#### Related Product Data:

**Contact Arrangements**—page 40

**Performance Characteristics**—page 41

**Interchangeable Crimp Snap-In Contacts**—page 121

**Application Tooling**—pages 121-123

**Mateable Connectors:**

**HDP**—pages 90-97

**HD-20 Board Mount**—pages 54-71, 78-85, 87-89

**Mating/Panel Mounting**—page 42

**Cable Clamps**—pages 132, 133, 135-137, 139, 140, 144, 145

**Mating Hardware**—pages 146-150, 153, 155

#### Technical Documents:

**Product Specification**—108-40011

**Application Specifications**—114-40002  
114-40003

**Instruction Sheet**—408-6621

**Note:** Instruction Sheets for TE Tooling are packaged with the tooling. For additional information call the Tooling Assistance Center: **1-800-722-1111**.

Shell Size	No. of Contact Positions	Dimensions		Contact Finish (Plating Code)	Connector Part Numbers
		A	B		Contact Identification No. 2 for 26-22 AWG [0.15-0.4mm <sup>2</sup> ] Wire Receptacle
1	9	1.213 30.81	.984 24.99	A	745201-7
				B	745201-9
2	15	1.541 39.14	1.312 33.33	A	745205-7
				B	745209-7
3	25	2.090 53.09	1.852 47.04	A	745209-7
				B	745209-8

- Notes:**
1. All connectors are preloaded with insulation displacement contacts. Pins in plug connectors and sockets in receptacle connectors. Contacts accept a max. wire insulation thickness of  $.015$  [0.38] and a max. wire insulation dia. of  $.060$  [1.52].
  2. HDE connectors are designed for terminating solid or stranded (7-strand max.) wire.
  3. Individual conductor strands should be larger than  $.005$  inch [0.127] diameter.
  4. Extraction Tool Part No. 91232-1 (Instruction Sheet 408-6631) is used to remove pin or socket contacts.
  5. For terminating more than one wire, or a drain wire, use crimp contacts on page 121.

**Note:** All part numbers are RoHS compliant.



## HDE-20 Metal-Shell IDC Connectors

### Plug

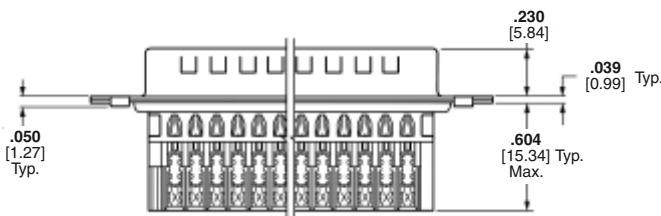

#### Material and Finish:

**Shell**—Steel, tin plated  
**Insert**—94V-0 rated thermoplastic, black

**Contacts**—Phosphor bronze  
**Contact Finish**—Duplex plated:  
**A**—.000030 [0.00076] gold on mating end, tin on termination end, with entire contact nickel underplated  
**B**—Gold flash on mating end, tin on termination end, with entire contact nickel underplated

#### Related Product Data:

- Contact Arrangements**—page 40
- Performance Characteristics**—page 41
- Interchangeable Crimp Snap-In Contacts**—page 121
- Application Tooling**—pages 121-123
- Mateable Connectors:**
  - HDP**—pages 90-97
  - HD-20 Board Mount**—pages 54-71, 78-85, 87-89
- Mating/Panel Mounting**—page 42
- Cable Clamps**—pages 132, 133, 135-137, 138, 140, 144, 145
- Mating Hardware**—pages 146-150, 153, 155

#### Technical Documents:

- Product Specification**—108-40011
- Application Specifications**—114-40002, 114-40003
- Instruction Sheet**—408-6645
- Note:** Instruction Sheets for TE Tooling are packaged with the tooling. For additional information call the Tooling Assistance Center: **1-800-722-1111**.

Shell Size	No. of Contact Positions	Dimensions		Contact Finish (Plating Code)	Connector Part Numbers		
					Contact Identification No. 1 for 30-26 AWG [0.05-0.15mm <sup>2</sup> ] Wire	Contact Identification No. 2 for 26-22 AWG [0.15-0.4mm <sup>2</sup> ] Wire	Contact Identification No. 3 for 22-20 AWG [0.4-0.6mm <sup>2</sup> ] Wire
					Plug	Plug	Plug
1	9	1.213 30.81	.984 24.99	A	1-745492-7	1-745492-8	1-745492-9
				B	—	2-745492-0	—
2	15	1.541 39.14	1.312 33.33	A	1-745494-7	1-745494-5	—
				B	—	1-745494-6	—
3	25	2.088 53.04	1.852 47.04	A	1-745496-9	1-745496-7	2-745496-0
				B	—	1-745496-8	—
4	37	2.729 69.32	2.500 63.50	A	1-745498-6	1-745498-5	—
				B	—	1-745498-7	—

- Notes:**
1. All connectors are preloaded with insulation displacement contacts. Pins in plug connectors and sockets in receptacle connectors. Contacts accept a max. wire insulation thickness of .015 [0.38] and a max. wire insulation dia. of .060 [1.52].
  2. Connectors can be made available with clinch nuts, contact TE.
  3. HDE connectors are designed for terminating solid or stranded (7-strand max.) wire.
  4. Individual conductor strands should be larger than .005 inch [0.127] diameter.
  5. Extraction Tool Part No. 91232-1 (Instruction Sheet 408-6631) is used to remove pin or socket contacts.
  6. For terminating more than one wire, or a drain wire, use crimp contacts on page 121.

**Note:** All part numbers are RoHS compliant.

## HDE-20 Metal-Shell IDC Connectors (Continued)

### Receptacle

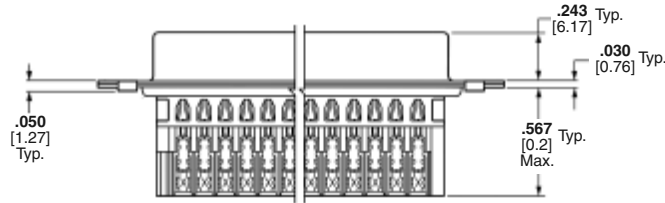
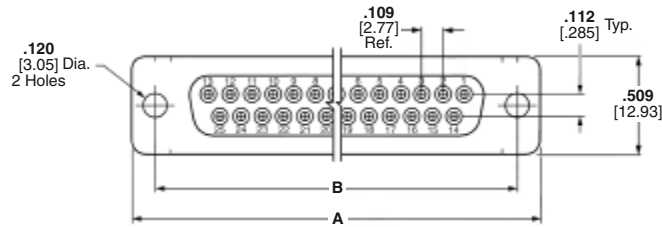

#### Material and Finish:

**Shell**—Steel, tin plated

**Insert**—94V-0 rated thermoplastic, black

**Contacts**—Phosphor bronze

**Contact Finish**—Duplex plated:  
**A**—.000030 [0.00076] gold on mating end, tin on termination end, with entire contact nickel underplated

**B**—Gold flash on mating end, tin on termination end, with entire contact nickel underplated

#### Related Product Data:

**Contact Arrangements**—page 40

**Performance Characteristics**—page 41

**Interchangeable Crimp Snap-In Contacts**—page 121

**Application Tooling**—pages 121-123

#### Mateable Connectors:

**HDP**—pages 90-97

**HD-20 Board Mount**—pages 54-71, 78-85, 87-89

**Mating/Panel Mounting**—page 42

**Cable Clamps**—pages 132, 133, 135-137, 139, 140, 144, 145

**Mating Hardware**—pages 146-150, 153, 155

#### Technical Documents:

**Product Specification**—108-40011

**Application Specifications**—114-40002  
114-40003

**Instruction Sheet**—408-6645

**Note:** Instruction Sheets for TE Tooling are packaged with the tooling. For additional information call the Tooling Assistance Center: **1-800-722-1111**.

Shell Size	No. of Contact Positions	Dimensions		Contact Finish (Plating Code)	Connector Part Numbers		
		A	B		Contact Identification No. 1 for 30-26 AWG [0.05-0.15mm <sup>2</sup> ] Wire	Contact Identification No. 2 for 26-22 AWG [0.15-0.4mm <sup>2</sup> ] Wire	Contact Identification No. 3 for 22-20 AWG [0.4-0.6mm <sup>2</sup> ] Wire
		Receptacle			Receptacle	Receptacle	
1	9	1.213 30.81	.984 24.99	A	1-745491-6	1-745491-7	1-745491-9
				B	—	1-745491-8	—
2	15	1.541 39.14	1.312 33.33	A	1-745493-6	1-745493-4	—
				B	—	1-745493-5	—
3*	25	2.088 53.04	1.852 47.04	A	1-745495-7	1-745495-8	1-745495-9
				B	—	2-745495-0	—
4	37	2.729 69.32	2.500 63.50	A	1-745497-6	1-745497-5	—
				B	—	1-745497-7	—

\* RS-232, size 3 connector, for 26-22 [0.15-0.4mm<sup>2</sup>] AWG wire select loaded circuits 1-8,15,17, 20 and 22, Plug Part No. 747740-1, Receptacle Part No. 747741-1, gold flash contacts.

- Notes:**
- All connectors are preloaded with insulation displacement contacts. Pins in plug connectors and sockets in receptacle connectors. Contacts accept a max. wire insulation thickness of .015 [0.38] and a max. wire insulation dia. of .060 [1.52].
  - Connectors can be made available with clinch nuts, contact TE.
  - HDE connectors are designed for terminating solid or stranded (7-strand max.) wire.
  - Individual conductor strands should be larger than .005 inch [0.127] diameter.
  - Extraction Tool Part No. 91232-1 (Instruction Sheet 408-6631) is used to remove pin or socket contacts.
  - For terminating more than one wire, or a drain wire, use crimp contacts on page 121.

**Note:** All part numbers are RoHS compliant.

## HDE-20 Basic Shielding Hardware Kits



**Each kit contains:**

- Connector
- Inner shield
- Outer shield

Ferrules must be purchased separately.

**Material and Finish:**

**Connector Shell**—Steel, tin plated

**Connector Insert**—94V-0 rated thermoplastic, black

**Shield**—Steel, tin plated

**Contacts**—Phosphor bronze

**Contact Finish**—Duplex plated:

**A**—.000030 [0.00076] gold on mating end, tin on termination end, with entire contact nickel underplated

**B**—Gold flash on mating end, tin on termination end, with entire contact nickel underplated

**Plug**

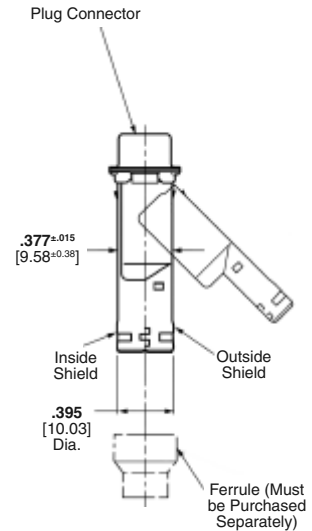
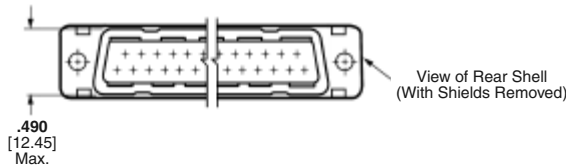
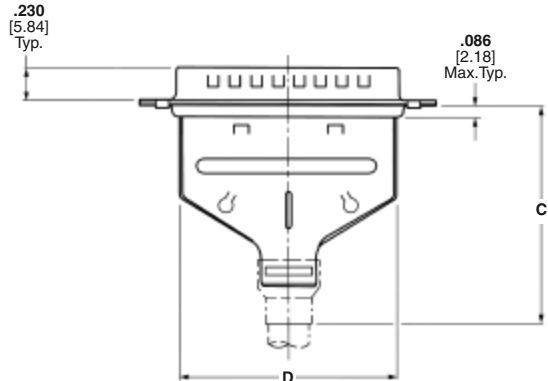
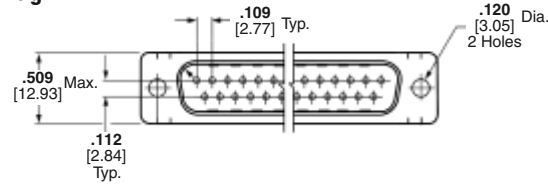

**Technical Documents:**

**Product Specifications**—

- 108-40011
- 108-40030

**Application Specifications**—

- 114-40002
- 114-40003
- 114-40006

**Instruction Sheet**—408-9010

**Note:** Instruction Sheets for TE Tooling are packaged with the tooling. For additional information call the Tooling Assistance Center: **1-800-722-1111**.

**Related Product Data:**

**Contact Arrangements**—page 40

**Performance Characteristics**—page 41

**Application Tooling**—pages 121-123

**Mateable Connectors:**

**HDP**—pages 90-97

**HD-20 Board Mount**—pages 54-71, 78-85, 87-89

**Mating Hardware**—pages 146-150, 153, 155

**Mating/Panel Mounting**—page 42

Shell Size	No. of Contact Pos.	Dimensions		Recommended Cable Outer Dia. Range	Max. Inner Cable Bundle Dia.†	Contact Finish (Plating Code)	Connector Part Numbers		
		C	D				Contact I.D. No. 1 for 30-26 AWG [0.05-0.15mm <sup>2</sup> ] Wire	Contact I.D. No. 2 for 26-22 AWG [0.15-0.4mm <sup>2</sup> ] Wire	Contact I.D. No. 3 for 22-20 AWG [0.4-0.6mm <sup>2</sup> ] Wire
							Plug	Plug	Plug
1	9	1.520 38.61	.678 17.22	.165-.455 4.19-11.56	.350 8.89	A	—	747515-7	—
							747531-7	747531-8	—
2	15	1.520 38.61	1.002 25.45	.165-.455 4.19-11.56	.350 8.89	A B	—	747531-9	—
							747547-8	747547-9	—
3	25	1.520 38.61	1.550 39.37	.165-.455 4.19-11.56	.350 8.89	A B	—	1-747547-0	—
							—	—	—
4	37	1.867 47.42	2.205 56.01	.338-.562 8.59-14.28	.450 11.43	A B	—	—	—
							—	1-747563-0	—

**Note:** Components of the kits are shipped unassembled and bulk-packaged in quantities of 100 pieces.

†Maximum cable diameter after jacket and braid removed.

**Note:** All part numbers are RoHS compliant.

## HDE-20 Basic Shielding Hardware Kits (Continued)



**Each kit contains:**

- Connector
- Inner shield
- Outer shield

Ferrules must be purchased separately.

**Material and Finish:**

**Connector Shell**—Steel, tin plated

**Connector Insert**—94V-0 rated thermoplastic, black

**Shield**—Steel, tin plated

**Contacts**—Phosphor bronze

**Contact Finish**—Duplex plated:

**A**—0.00030 [0.00076] gold on mating end, tin on termination end, with entire contact nickel underplated

**B**—Gold flash on mating end, tin on termination end, with entire contact nickel underplated

**Related Product Data:**

**Contact Arrangements**—page 40

**Performance Characteristics**—page 41

**Application Tooling**—pages 121-123

**Mateable Connectors:**

**HDP**—pages 90-97

**HD-20 Board Mount**—pages 54-71, 78-85, 87-89

**Mating Hardware**—pages 146-150, 153, 155

**Mating/Panel Mounting**—page 42

**Receptacle**



**Technical Documents:**

**Product Specifications**—

108-40011

108-40030

**Application Specifications**—

114-40002

114-40003

114-40006

**Instruction Sheet**—408-9010

**Note:** Instruction Sheets for TE Tooling are packaged with the tooling. For additional information call the Tooling Assistance Center: **1-800-722-1111**.

Shell Size	No. of Contact Pos.	Dimensions		Recommended Cable Outer Dia. Range	Max. Inner Cable Bundle Dia.†	Contact Finish (Plating Code)	Connector Part Numbers		
							Contact I.D. No. 1 for 30-26 AWG [0.05-0.15mm <sup>2</sup> ] Wire	Contact I.D. No. 2 for 26-22 AWG [0.15-0.4mm <sup>2</sup> ] Wire	Contact I.D. No. 3 for 22-20 AWG [0.4-0.6mm <sup>2</sup> ] Wire
							Receptacle	Receptacle	Receptacle
1	9	1.520 38.61	.678 17.22	.165-.455 4.19-11.56	.350 8.89	A	—	747516-7	747516-8
							—	747516-9	—
2	15	1.520 38.61	1.002 25.45	.165-.455 4.19-11.56	.350 8.89	A	—	747532-7	—
							—	747532-8	—
3	25	1.520 38.61	1.550 39.37	.165-.455 4.19-11.56	.350 8.89	A	—	747548-8	—
							—	747548-9	—
4	37	1.867 47.42	2.205 56.01	.338-.562 8.59-14.28	.450 11.43	B	747564-8	747564-9	—

**Note:** Components of the kits are shipped unassembled and bulk-packaged in quantities of 100 pieces.

†Maximum cable diameter after jacket and braid removed.

**Note:** All part numbers are RoHS compliant.

## HDE-20 Shielding Hardware Enclosure Kits



**Each kit contains:**

- Connector
- Inner shield
- Outer shield
- Enclosure
- Two jackscrews

Ferrules must be purchased separately.

**Material and Finish:**

**Connector Shell**—Steel, tin plated

**Connector Insert**—94V-0 rated thermoplastic, black

**Shield**—Steel, tin plated

**Enclosure**—PVC, black

**Jackscrews**—Zinc alloy

**Contacts**—Phosphor bronze

**Contact Finish**—Duplex plated:

**A**—.000030 [0.00076] gold on mating end, tin on termination end, with entire contact nickel underplated

**B**—Gold flash on mating end, tin on termination end, with entire contact nickel underplated

**Related Product Data:**

**Contact Arrangements**—page 40

**Performance Characteristics**—page 41

**Application Tooling**—pages 121-123

**Mateable Connectors:**

**HDP**—pages 90-97

**HD-20 Board Mount**—pages 54-71, 78-85, 87-89

**Mating Hardware**—pages 146-150, 153, 155

**Mating/Panel Mounting**—page 42

**Plug**

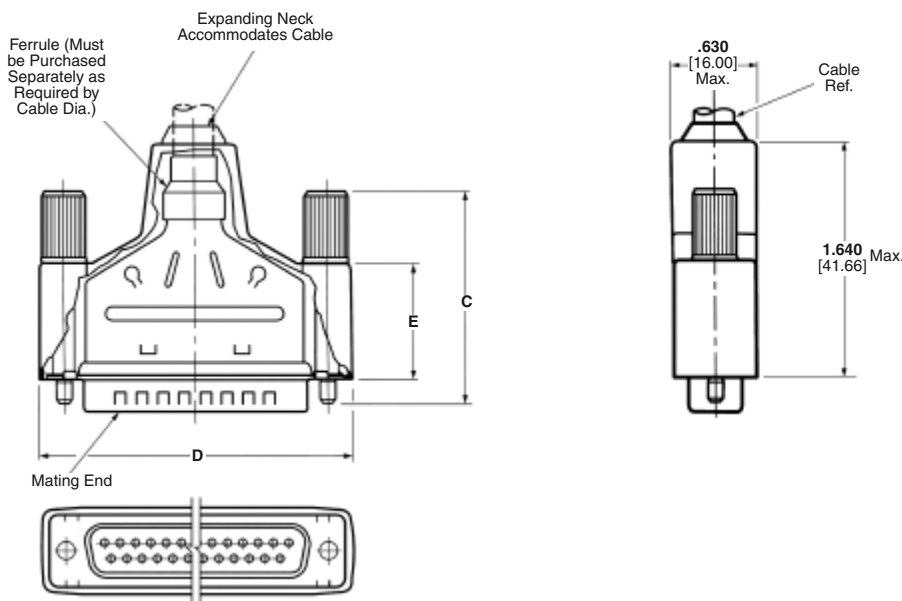

**Technical Documents:**

**Product Specifications**—

- 108-40011
- 108-40030

**Application Specifications**—

- 114-40002
- 114-40003
- 114-40006
- 114-40008

**Instruction Sheet**—408-9172

**Note:** Instruction Sheets for TE Tooling are packaged with the tooling. For additional information call the Tooling Assistance Center: **1-800-722-1111**.

Shell Size	No. of Contact Pos.	Dimensions			Recommended Cable Outer Dia. Range	Max. Inner Cable Bundle Dia.†	Contact Finish (Plating Code)	Kit Part Numbers			Shielding Enclosure Expansion Tool	
		C	D	E				Contact I.D. No. 1 for 30-26 AWG [0.05-0.15mm <sup>2</sup> ]	Contact I.D. No. 2 for 26-22 AWG [0.15-0.4mm <sup>2</sup> ]	Contact I.D. No. 3 for 22-20 AWG [0.4-0.6mm <sup>2</sup> ]	Cable O.D. (Max.)	Part No.
1	9	1.640 41.66	1.355 34.42	.630 16.00	.190-.330 4.83-8.38	.330 8.38	A	—	1-747944-5	—	.330 8.38	58241-4
							B	—	1-747944-6	—		
2	15	1.640 41.66	1.685 42.80	.630 16.00	.190-.330 4.83-8.38	.330 8.38	A	—	1-747946-5	—	.450 11.43	58241-1
							B	—	1-747946-6	—		
3	25	1.640 41.66	2.210 56.13	.630 16.00	.217-.435 5.51-11.05	.350 8.89	A	1-747948-5	1-747948-6	—	.572 14.52	58241-2
							B	—	1-747948-8	1-747948-9		
4	37	2.010 51.05	2.865 72.77	.730 18.54	.338-.562 8.59-14.28	.450 11.43	A	1-747950-4	1-747950-5	—	.572 14.52	58241-2
							B	—	1-747950-6	—		

†Maximum cable diameter after jacket and braid removed.

**Note:** All part numbers are RoHS compliant.

## HDE-20 Shielding Hardware Enclosure Kits (Continued)



### Receptacle

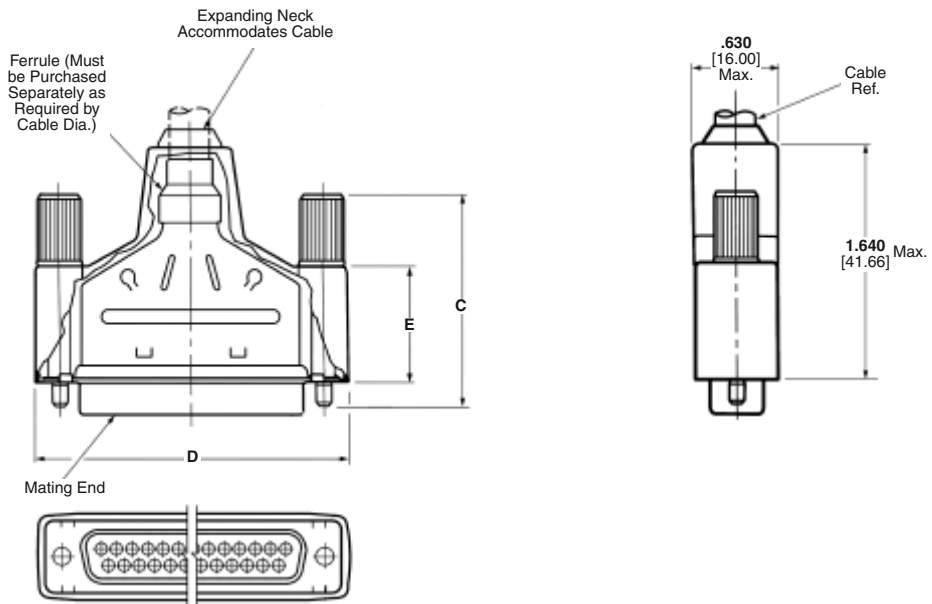

**Each kit contains:**

- Connector
- Inner shield
- Outer shield
- Enclosure
- Two jackscrews

Ferrules must be purchased separately.

**Material and Finish:**

**Connector Shell**—Steel, tin plated

**Connector Insert**—94V-0 rated thermoplastic, black

**Shield**—Steel, tin plated

**Enclosure**—PVC, black

**Jackscrews**—Zinc alloy

**Contacts**—Phosphor bronze

**Contact Finish**—Duplex plated:

**A**—.000030 [0.00076] gold on mating end, tin on termination end, with entire contact nickel underplated

**B**—Gold flash on mating end, tin on termination end, with entire contact nickel underplated

**Related Product Data:**

**Contact Arrangements**—page 40

**Performance Characteristics**—page 41

**Application Tooling**—pages 121-123

**Mateable Connectors:**

**HDP**—pages 90-97

**HD-20 Board Mount**—pages 54-71, 78-85, 87-89

**Mating Hardware**—pages 146-150, 153, 155

**Mating/Panel Mounting**—page 42

**Technical Documents:**

**Product Specifications**—

108-40011

108-40030

**Application Specifications**—

114-40002

114-40003

114-40006

114-40008

**Instruction Sheet**—408-9172

**Note:** Instruction Sheets for TE Tooling are packaged with the tooling. For additional information call the Tooling Assistance Center: **1-800-722-1111**.

Shell Size	No. of Contact Pos.	Dimensions			Recommended Cable Outer Dia. Range	Max. Inner Cable Bundle Dia.†	Contact Finish (Plating Code)	Kit Part Numbers		Shielding Enclosure Expansion Tool	
		C	D	E				Contact I.D. No. 1 for 30-26 AWG [0.05-0.15mm <sup>2</sup> ]	Contact I.D. No. 2 for 26-22 AWG [0.15-0.4mm <sup>2</sup> ]	Cable O.D. (Max.)	Part No.
								Receptacle	Receptacle		
1	9	1.640	1.355	.630	.190-.330	.330	A	1-747943-5	1-747943-6	.330	58241-4
		41.66	34.42	16.00				4.83-8.38	8.38		
2	15	1.640	1.685	.630	.190-.330	.330	A	1-747945-5	—	.330	58241-1
		41.66	42.80	16.00				4.83-8.38	8.38		
3	25	1.640	2.210	.630	.217-.435	.350	A	1-747947-5	1-747947-6	.450	58241-1
		41.66	56.13	16.00				5.51-11.05	8.89		
4	37	2.010	2.865	.730	.338-.562	.450	A	—	—	.572	58241-2
		51.05	72.77	18.54				8.59-14.28	11.43		

†Maximum cable diameter after jacket and braid removed.

**Note:** All part numbers are RoHS compliant.

## HDE-20 Crimp Snap-In Contact Connectors

### Ferrules for Shielding Hardware Kits



Stepped



Straight

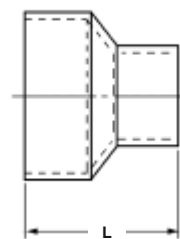
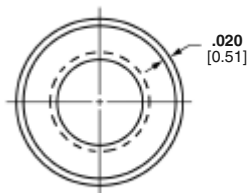

#### Material and Finish:

Steel (annealed), tin plated

#### Related Product Data:

**Shielding Hardware and Enclosure Kits**—pages 116-119

#### Technical Documents:

##### Instruction Sheets—

 408-9242  
 408-9243  
 408-9507  
 408-9508

**Note:** Instruction Sheets for TE Tooling are packaged with the tooling. For additional information call the Tooling Assistance Center: **1-800-722-1111**.

Shell Sizes	Style	L Dim.	Cable Diameter	Part Numbers	
				Ferrule	Die Sets*
1-3	Stepped	.440 11.18	.165-.190 4.19-4.83	3-747579-0	543424-3
1-3	Stepped	.440 11.18	.190-.217 4.83-5.51	3-747579-0	543424-2
1-3	Stepped	.440 11.18	.217-.246 5.51-6.25	3-747579-0	543424-8
1-3	Stepped	.440 11.18	.246-.284 6.25-7.21	3-747579-2	543424-1
1-3	Stepped	.440 11.18	.284-.324 7.21-8.23	3-747579-2	543424-7
1-3	Stepped	.440 11.18	.324-.375 8.23-9.53	3-747579-4	543424-6
1-3	Straight	.440 11.18	.375-.435 9.53-11.05	2-747579-7	543424-5
1-3	Straight	.440 11.18	.400-.455 10.16-11.56	3-747579-6	543424-4
4	Stepped	.625 15.88	.230-.265 5.84-6.73	2-747580-4	543425-2
4	Stepped	.625 15.88	.338-.385 8.59-9.78	2-747580-3	543425-1
4	Stepped	.625 15.88	.375-.432 9.53-10.97	2-747580-1	58238-1
4	Stepped	.625 15.88	.422-.490 10.72-12.45	3-747580-1	58237-2
4	Straight	.625 15.88	.480-.562 12.19-14.28	2-747580-2	58237-1

\*Die sets used with Hand Crimping Tool Part No. 543344-1 or Pneumatic Bench Tool Part No. 312522-3 equipped with Die Set Holder Part No. 58449-1.

### Application Tooling for Shielding Hardware Kits



**Hand Crimping Tool**  
 No. 543344-1  
 (Requires Die Sets, see table above.)

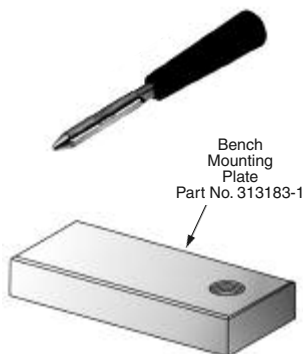

**Shielding Enclosure Expansion Tools**  
 Part No. 58241-1 (.450 [11.43])†  
 58241-2 (.572 [14.53])†  
 58241-4 (.330 [8.38])†  
 †Maximum Cable Diameter  
 (Instruction Sheet—408-9507)

**Pneumatic Bench Tool**  
 No. 312522-3  
 (Requires Die Set Holder No. 58449-1.)



**Note:** All part numbers are RoHS compliant.

## HDE-20 Contacts, Precision Formed

### Material and Finish:

Phosphor bronze, duplex plated as follows:

**A**—Duplex plated .000030 [0.00076] gold on mating end, tin on termination end, with entire contact nickel underplated

**B**—Gold flash on mating end, tin on termination end, with entire contact nickel underplated

### Interchangeable Contacts, Crimp Snap-In



Pin

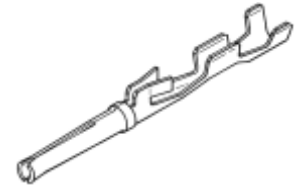

Socket

### Related Product Data:

**Performance Characteristics**—page 41

**Connectors used with:**  
HDE—pages 112-119

### Technical Documents:

**Product Specifications**—  
108-40011  
108-40030

**Application Specifications**—  
114-40002  
114-40003  
114-40006  
114-40008

**Instruction Sheet**—408-6738

**Note:** Instruction Sheets for TE Tooling are packaged with the tooling. For additional information call the Tooling Assistance Center: **1-800-722-1111**.

Wire Size Range AWG mm <sup>2</sup>	Code*	Insulation Diameter		Contact Finish (Plating Code)	Contact Part Numbers	
		Single Wire	Two Wire		Pin Strip Form	Socket Strip Form
26-22 0.15-0.4	4	.054	.039	A	—	1-745269-1
		1.37	0.99	B	1-745266-0	1-745269-0
22-18 0.4-0.8	3	.075	.054	A	1-745267-0	1-745270-1
		1.91	1.37	B	—	1-745270-0

\* A Code indicating accepted wire size range is stamped inside insulation crimp barrel of each contact.

**Notes:** 1. Extraction Tool No. 91232-1 is used to remove pin and socket contacts.  
2. Strip form contacts shipped 10,000 pieces/reel.

**Note:** All part numbers are RoHS compliant.



## HDE-20 Application Tooling

### Hand Tools with Modular Heads

#### Technical Documents:

##### Instruction Sheets—

408-6790  
408-9414  
408-6789

**Note:** Instruction Sheets for TE Tooling are packaged with the tooling. For additional information call the Tooling Assistance Hotline: **1-800-722-1111**.

A modular interchangeable head provides versatility to these tools. Along with the head used to terminate Subminiature D connectors, heads are available to terminate other TE product lines.

The head used to terminate the Subminiature D, HDE connectors can be used with a manual pistol grip tool, an air pistol grip tool and a bench mount power assembly. These tools terminate one unstripped wire per cycle and index the connector to the next terminating position. The head rotates to permit optimum access to the wiring area.

### Manual Pistol Grip Tool



**Handle and Head Tool Assembly No. 608868-1**  
**Handle No. 58074-1**  
**Head Assembly No. 58063-2**

This tool is manually actuated, using modular heads.

### Air Pistol Grip Tool



**Handle No. 58075-1**  
**Head Assembly No. 58063-2**

Air actuated, utilizing modular heads.

### Bench Mounted Tools with Modular Heads

#### Bench Mount Pneumatic Power Assembly



**Bench Assembly No. 58338-1**  
**Head Assembly No. 58063-2**

This tool is air actuated with either a foot or knee switch.

#### Bench Mount Electric Power Assembly



**Head Assembly No. 58063-2**

This tool electrically powered and actuated by a foot switch.

**Note:** All part numbers are RoHS compliant.

**HDE-20 Application Tooling** (Continued)

**Product Facts**

- Low applied costs
- Automatic termination of jacketed cable
- Automatic continuity check and shorts test
- Single- or double-ended assemblies
- Microprocessor controlled with touch input screen
- Stored program capability
- Selective termination of connector positions
- Rapid tooling changeover for different connector types
- Handles a variety of TE insulation-displacement connectors
- Terminates both multicolor and single-color wires
- Remote programming capability
- Straight or right-angle wire dress
- Control Module 852423-1 120 VAC



**CHAMPOMATOR 3A Terminating Machine**

This machine is the high-productivity way to terminate multiconductor, jacketed cable with a variety of TE connectors having insulation displacement contacts. It automatically sorts the wires, and terminates them in a programmed sequence. The sequence may use all or some of the connector contacts, such as for various RS-232 wiring patterns.

All cable assemblies are tested for continuity and shorts.

The machine is microprocessor controlled, and programmed by a touch input screen. The easy programming simplifies the process and reduces training requirements. The machine's internal storage capability can retain up to 50 cable assemblies, which can be easily retrieved by number or name. Production monitoring and diagnostics can also be accessed through the touch screen.

Contact TE for the tooling required for your specific applications.

**Technical Documents:**

**Instruction Sheets**

408-7777 Manual Arbor Tool

**Note:** Instruction Sheets for TE Tooling are packaged with the tooling. For additional information call the Tooling Assistance Center: **1-800-722-1111**.



**Control Module**  
No. 852423-1

**CHAMPOMATOR 2.5 Machine**  
No. 354786-4

**CHAMPOMATOR 2.5 Terminating Machine**

This is a compact, semi-automatic bench machine. It is microprocessor controlled, and programmed using a membrane switch keyboard. The potential machine rate is one pair of wires per second. Contact TE for the tooling required for your specific applications.

The CHAMPOMATOR Model 2.5 Bench Terminating Machine—**Part No. 354786-4** is used in conjunction with Control Module—**Part No. 852423-1**.

Contact TE for application specific requirements.

**Manual Arbor Tool**



**Arbor Tool No. 91085-2**  
Applicators:

Wire O.D. .041-.060 [1.04-1.52]—No. 543157-1 (tool mount), 543426-1 (termination tool)

Wire O.D. .040 [1.02] and smaller—No. 543157-1 (tool mount), 543426-2 (termination tool)



**Manual Arbor Tool**

The arbor tool with applicator is used to terminate jacketed cable. Wires are neatly routed and trimmed to length with the cable jacket close to the connector. 400 to 800 terminated wires per hour are typical.

**Note:** All part numbers are RoHS compliant.

## Subminiature D Connectors HDF-20 for Flat Ribbon Cable

### Product Facts

- Available in all 5 standard shell sizes
- Visual inspection of termination possible
- Fluted cover provides positive alignment of cable prior to termination
- Wide range of application tooling
- Patented insulation displacement contact latches into the connector cover
- Contact design provides a “gas-tight” termination
- Contacts accept 28 AWG [0.08mm<sup>2</sup>] solid and stranded, and 26 AWG [0.15mm<sup>2</sup>] solid and stranded round conductor flat ribbon cable on .050 [1.27] centers
- Qualified to Battelle Level III environment
- Recognized under the Component Program of Underwriters Laboratories Inc., File No. E28476 
- Certified by Canadian Standards Association, File No. LR 7189 
- Listed and complies with UL 1863, Communication Circuit Accessories File No. E81956 

### Plug — Low Profile Metal Shell



### Receptacle — Low Profile Metal Shell



No. of Pos. & (Shell Size)	Cable Stabilizer Part No.	Plug Part Nos.		Receptacle Part Nos.	
		With Standard Mounting Holes	With 4-40 Threaded Inserts	With Standard Mounting Holes	With 4-40 Threaded Inserts
9 (1)	747275-4	1658613-4	1658608-4	1658612-4	1658610-4
15 (2)	747275-3	1658613-3	1658608-3	1658612-3	1658610-3
25 (3)	747275-2	1658613-2	1658608-2	1658612-2	1658610-2
37 (4)	747275-1	1658613-1	1658608-1	1658612-1	1658610-1
50 (5)	746785-1	—	1658607-1	—	1658606-1

**Note:** All assemblies are supplied with housing and cover pre-assembled. Optional cable stabilizer must be ordered separately.

### Material

**Front Shell**—Steel, tin or tin plated

**Housing, Cover & Cable Stabilizer**—Thermoplastic, 94V-0, black

**Threaded Inserts**—Brass, unplated

**Contacts**—Phosphor bronze, duplex plated .000030 [0.00076] min. gold on mating end, .000100-.000200 [0.00254-0.00508] bright tin on termination end with entire contact underplated .000050 [0.00127] min. nickel

### Related Product Data

**Contact Arrangement**—page 40

**Performance Characteristics**—page 41

### Mateable Receptacles:

**HDF-20 Metal-Shell**—page 124

**HDE**—pages 110-121 (Sizes 1-4 only)

**HDP**—pages 90-109

**HD-20 Board Mount**—pages 54-71, 78-85, 87-89

**Mating/Panel Mounting**—page 126

**Ribbon Cable**—page 125

### Accessories:

**Commoning Strip**—page 146

**Mating Hardware**—pages 146-150, 153 & 154

**Application Tooling**—page 127

### Technical Documents

**Product Specification**—108-40012

**Note:** All part numbers are RoHS compliant.

## HDF-20 Low Profile All-Plastic Connectors (for Round Conductor Flat Ribbon Cable)

### Material and Finish

#### Housing, Cover & Cable

**Stabilizer**—Black thermoplastic, 94V-0 rated

**Threaded Inserts**—Brass, unplated

**Pin Contacts**—Phosphor bronze, duplex plated .000030 [0.00076] gold on mating end, .000100-.000200 [0.00254-0.00508] bright tin on termination end, with entire contact underplated .000050 [0.00127] nickel

### Related Product Data

**Contact Arrangement**—page 40

**Performance Characteristics**—page 41

#### Mateable Receptacles:

**HDF-20 All-Plastic**—page 124

**HD-20 Board Mount**—pages 54-71, 78-85, 87-89

**HDE All-Plastic**—pages 147, 148

**Mating/Panel Mounting**—page 126

**Ribbon Cable**—page 125

#### Accessories:

**Mating Hardware**—pages 146-150, 153, 155

**Application Tooling**—page 127

### Technical Documents

#### Product Specifications—

108-40012 HDF-20 Low Profile Connectors

### Plug Assemblies



Housing and Covers are Preassembled; Cable Stabilizer is Separate.

### Receptacle Assemblies



Housing and Covers are Preassembled; Cable Stabilizer is Separate.

No. of Contact Pos. & (Shell Size)	Optional Cable Stabilizer Part No.	Plug Assembly Part No.		Receptacle Assembly Part No.	
		With Standard Mounting Holes	With Threaded Inserts	With Standard Mounting Holes	With Threaded Inserts
9 (1)	747275-4	1658615-4	1658611-4	1658614-4	1658609-4
15 (2)	747275-3	1658615-3	1658611-3	1658614-3	1658609-3
25 (3)	747275-2	1658615-2	1658611-2	1658614-2	1658609-2
37 (4)	747275-1	1658615-1	—	1658614-1	1658609-1

**Note:** All assemblies are supplied with housing and cover pre-assembled. Optional cable stabilizer must be ordered separately.

### Ribbon Cable Parameters

No. of Conductors	28 AWG [0.08mm <sup>2</sup> ] Part No.		26 AWG [0.15mm <sup>2</sup> ] Part No.
	Length Per Reel		Length Per Reel
	100 Ft. [30.5m]	500 Ft. [152.4m]	500 Ft. [152.4m]
9	1-57040-2	1-971111-2	57034-2
15	1-57040-5	1-971111-5	57034-5
25	57040-2	971111-2	57034-9
37	1-57040-8	1-971111-8	1-57034-3
50	57040-6	971111-6	1-57034-5

**Note:** All part numbers are RoHS compliant.

## HDF-20 Plugs/Receptacles Mating and Panel Mounting Specifications

### Plug/Receptacle Mating



The .265/.256 [6.73/6.50] dimensions are required to assure full mating of connector halves. These dimensions must be taken into consideration when determining the method of mounting, panel thickness, etc.

### Panel Mounting

Plugs and receptacles can be mounted to a panel from either the front or rear, using a variety of accessory hardware. Typical examples are shown below.



Typical Front-Panel Mounted HDF-20 Plug



Typical Rear-Panel Mounted HDF-20 Plug

### Panel Cutouts

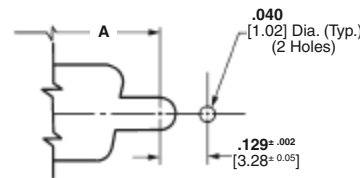

Cutout for Rear Mount and Short Latching Blocks

Shell Size (Pos.)	Mounting Method Front/Rear Panel	Dimensions								
		A	B	C	D	E	F	H*	J*	K
1 (9)	Front	.984 24.99	.492 12.50	.874 22.20	.437 11.10	.513 13.03	.257 6.53	—	—	.083 2.11
	Rear	.984 24.99	.492 12.50	.806 20.47	.403 10.24	.449 11.41	.225 5.72	13.97	19.05	.132 3.35
2 (15)	Front	1.312 33.33	.656 16.66	1.202 30.53	.601 15.27	.513 13.03	.257 6.53	—	—	.083 2.11
	Rear	1.312 33.33	.656 16.66	1.134 28.80	.567 14.40	.449 11.41	.225 5.72	18.54	19.05	.132 3.35
3 (25)	Front	1.852 47.04	.926 23.52	1.743 44.27	.872 22.15	.513 13.03	.257 6.53	—	—	.083 2.11
	Rear	1.852 47.04	.926 23.52	1.674 42.52	.842 21.39	.449 11.41	.225 5.72	32.39	19.05	.132 3.35
4 (37)	Front	2.500 63.50	1.250 31.75	2.391 60.73	1.196 30.38	.513 13.03	.257 6.53	—	—	.083 2.11
	Rear	2.500 63.50	1.250 31.75	2.326 59.08	1.163 29.54	.449 11.41	.225 5.72	46.05	16.13	.132 3.35
5 (50)	Front	2.406 61.11	1.203 30.56	2.297 58.34	1.149 29.19	.623 15.82	.312 7.93	—	—	.083 2.11
	Rear	2.406 61.11	1.203 30.56	2.218 56.34	1.109 28.17	.555 14.10	.278 7.06	44.52	19.05	.132 3.35

\*Panel cutout configuration with H and J dimensions provides clearance for mounting connectors with cable clamps.

---

## HDF-20 Application Tooling

---

### Application Tooling



**Hand Tool Kit No. 768340-1**



Consists of a hand tool frame, a universal base assembly, a bench mount kit, and connector-specific tooling for AMP-LATCH Standard and Novo Receptacles, Card-Edge Connectors, and AMPLIMITE HDF-20 Connectors.

**Note:** For 50-position HDF connectors, you must also order Connector-Specific Kit No. 768350-1.

**Note:** All part numbers are RoHS compliant.

## HD-20 Solder Cup Connectors

### Product Facts

- Preloaded duplex-plated solder cup contacts
- Shell finish in choice of standard zinc or tin
- Two-piece 94V-0 rated plastic insert
- Anti-solderwicking contact design
- Intermateable with other subminiature D connectors
- Available in 9, 15, 25 and 37 position (shell sizes 1-4) plugs and receptacles
- Easy application without special application tools
- Shields offer full EMI shielding and ESD insulation
- Crimped shield termination for low impedance
- Shield crimp provides strain relief
- Shields may be post molded or covered with enclosures
- Recognized under the Component Program of Underwriters Laboratories, Inc.,  File No. E28476
- Listed under Underwriters Laboratories Inc., connectors for use in data, signal, control & Power Applications — components,  File No. E127344
- Certified by Canadian Standards Association,  File No. LR 97981



## HD-20 Solder Cup Connectors (Continued)



### Plug



#### Material and Finish:

**Shell**—Steel, tin or zinc plated

**Insert**—94V-0 rated thermoplastic, black

**Contacts**—Phosphor bronze; duplex plated with gold flash on mating end, tin on solder cup, with entire contact nickel underplated

#### Related Product Data:

##### Mateable Connectors:

**HDE**—pages 110-119

**HDF**—pages 124-126

**HDP**—pages 90-101

**HD-20 Solder Cup**—pages 128-130

**HD-20 Board Mount**—pages 54-71, 78-85, 87-89

**Cable Clamps**—pages 132, 133, 135-137, 140, 141, 144, 145

**Mating Hardware**—pages 146-150, 151-154

#### Technical Documents:

##### Product Specification

108-40031

##### Instruction Sheet

408-9193

### Receptacle

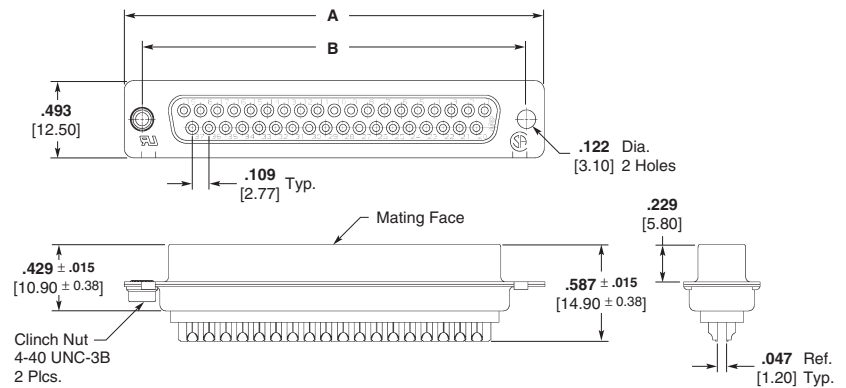

Shell Size	No. of Contact Positions	Dimensions		Plug Part Numbers		Receptacle Part Numbers	
		A	B	Tin Plated Shell	Zinc Plated Shell	Tin Plated Shell	Zinc Plated Shell
1	9	1.210	.984	5-747904-2	5-747904-2	5-747905-2	5-747905-2
		30.80	24.99				
2	15	1.544	1.313	5-747908-2	5-747908-2	5-747909-2	5-747909-2
		39.20	33.32				
3	25	2.089	1.853	5-747912-2	5-747912-2	5-747913-2	5-747913-2
		53.01	47.04				
4	37	2.734	2.502	5-747916-2	5-747916-2	5-747917-2	747917-4
		69.40	63.50				

**Note:** All part numbers are RoHS compliant.



## HD-20 Solder Cup Shielding Hardware Enclosure Kits

### Plug and Receptacles



#### Each kit contains

- Connector with preloaded, nonremovable contacts
- Shield
- Enclosure
- Two jackscrews

#### Material and Finish:

**Connector Shell**—Steel, tin plated

**Connector Insert**—94V-0 rated thermoplastic, black

**Shields**—Steel, tin plated

**Enclosure**—PVC, black

**Jackscrews**—Brass, zinc coated

**Contacts**—Phosphor bronze; duplex plated with gold flash on mating end, tin on solder cup, with entire contact nickel underplated

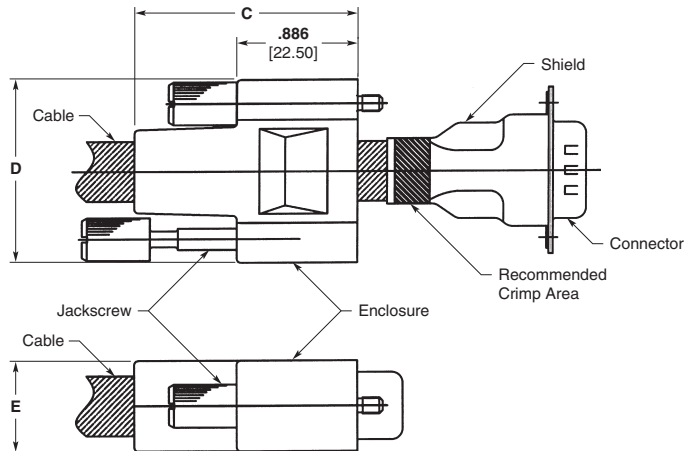

Shell Size	No. of Contact Positions	Dimensions			Cable Insulation Diameter	Kit Part Numbers		Shielding Enclosure Expansion Tool	
		C	D	E		Plug	Receptacle	Cable O.D. (Max.)	Part Number
1	9	1.64 41.67	1.33 33.74	.659 16.74	.217-.270 5.51-6.86	1571650-4	1571654-4	.355 9.02	58241-4
					.270-.324 6.86-8.23	1571650-5	1571654-5		
					.324-.385 8.23-9.78	1571650-6	1571654-6		
2	15	1.64 41.67	1.65 41.86	.659 16.74	.217-.270 5.51-6.86	1571651-4	1571655-4	.355 9.02	58241-4
					.270-.324 6.86-8.23	1571651-5	1571655-5		
					.324-.385 8.23-9.78	1571651-6	1571655-6		
3	25	1.64 41.67	2.20 55.86	.659 16.74	.217-.270 5.51-6.86	1571652-4	1571656-4	.465 11.56	58241-1
					.270-.324 6.86-8.23	1571652-5	1571656-5		
					.324-.385 8.23-9.78	1571652-6	1571656-6		
4	37	2.35 59.67	2.82 71.63	.659 16.74	.455-.480 11.58-12.19	1571653-2	1571657-2	.562 14.28	58241-2

**Note:** Components of the kits are shipped unassembled and bulk-packaged in quantities of 100 pieces.

#### Related Product Data:

##### Mateable Connectors:

**HDE**—pages 110-119

**HDF**—pages 124-126

**HDP**—pages 90-101

**HD-20 Solder Cup**—pages 128-130

**HD-20 Board Mount**—pages 82-85, 87-89

#### Technical Documents:

##### Product Specification

108-40031

##### Instruction Sheets

408-9193

### HD-20 Solder Cup Shielding Hardware Crimping Tool

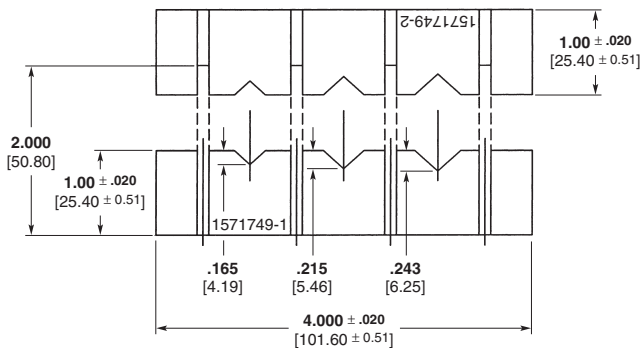

**Assembled Tooling: Part Number 1571750-1**  
**Individual Tools (for customer fabrication):**  
 1571749-1 & 1571749-2

**Note:** All part numbers are RoHS compliant.

## Accessories

Numerous accessories are available for strain relief and cable clamping, shielding, connector-to-connector mating, connector-to-connector pc board mounting, and keying. These accessories are illustrated and tabled on the following pages.

To help discern the accessories available for a particular connector type, refer to the Product Selection Guide at the beginning of the connector section. Also, the connector the accessory is used with is listed under the Related Product Data heading next to the accessory listing.



### Section Contents

#### Unshielded Cable Clamps

Universal Cable Clamps for Jacketed Cable .....	132
One-Piece, All-Plastic Cable Clamp .....	133, 134
Straight/90° Low Profile Cable Clamps .....	135
Slide-On Back Covers .....	136
Box and Lid, Straight/90° Exit .....	137
Clam Shell, Straight/45° .....	138
Straight Exit, Dataphone .....	139
Straight Exit for Jacketed Cable (Two-Piece) .....	139
Straight/90° Exit .....	140

#### Shielded Cable Clamps

Straight Exit RFI/EMI Shields for Jacketed Cable (HDE, HDP) .....	141
Straight/90° Exit RFI/EMI Die Cast Shields for Jacketed Cable (HDE, HDP) .....	142
Crimp and Split-Ring Ferrules .....	143-145

#### Hardware

Commoning Strip .....	146
Male Screw Retainers for Metal-Shell Connectors (HDE, HDP) .....	146
Male Screw Retainers for All-Plastic Connectors (HDE) ..	147
Male Screw Retainers for Metal-Shell and All-Plastic Connectors (HDF) .....	147
Female Screwlocks for Metal-Shell and All-Plastic Connectors (HDE, HDF, HDP) .....	148
Slide Latches .....	149, 150
Slide Latch Clips .....	151
Locking Post Assemblies .....	151
Spring Latches (Two-Piece) .....	152
Latching Blocks (HDE, HDF, HDP, HD) .....	153, 154
Standoff Bushings .....	155
Keying Plug .....	155
EMI/RFI Gasket .....	155

## Unshielded Cable Clamps

### Universal Cable Clamps for Jacketed Cable

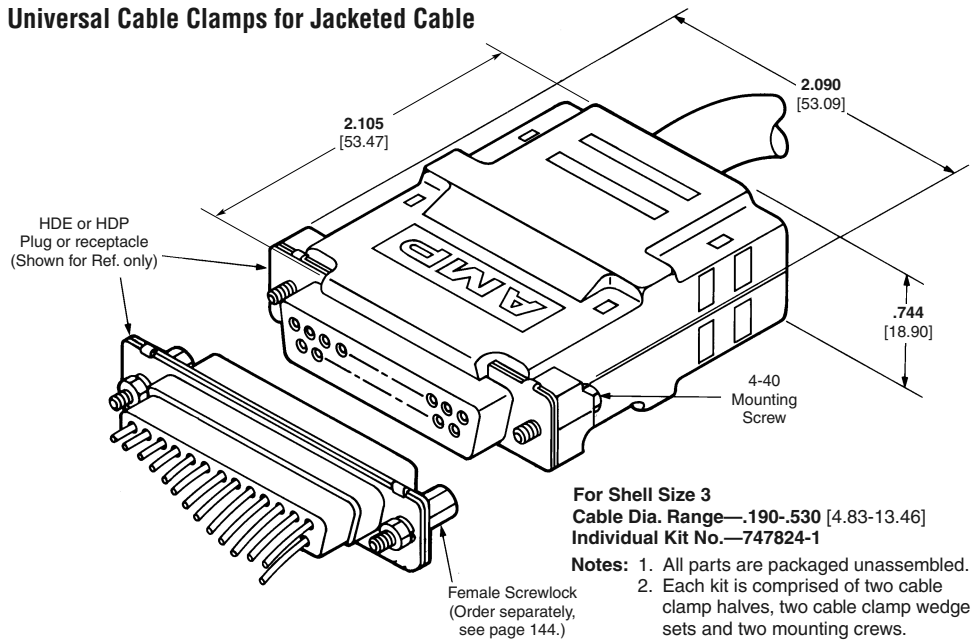

**For Shell Size 3**  
**Cable Dia. Range—190-530 [4.83-13.46]**  
**Individual Kit No.—747824-1**

- Notes:**
1. All parts are packaged unassembled.
  2. Each kit is comprised of two cable clamp halves, two cable clamp wedge sets and two mounting crews.

**Material and Finish:**

**Cable Clamp Housing—**  
Thermoplastic, black

**Cable Clamp Wedge Set—**  
Thermoplastic, black

**4-40 Mounting Screws—**  
Steel, zinc plated

**Related Product Data:**

**Connectors used with:**  
**HDE Metal-Shell—**pages 114 & 115  
**HDP Metal-Shell—**pages 90-102

**Other accessory capabilities:**  
**Spring Latches (Two Piece)—**  
page 152

**Technical Documents:**

**Instruction Sheet—**408-9238

### Straight/90° Exit

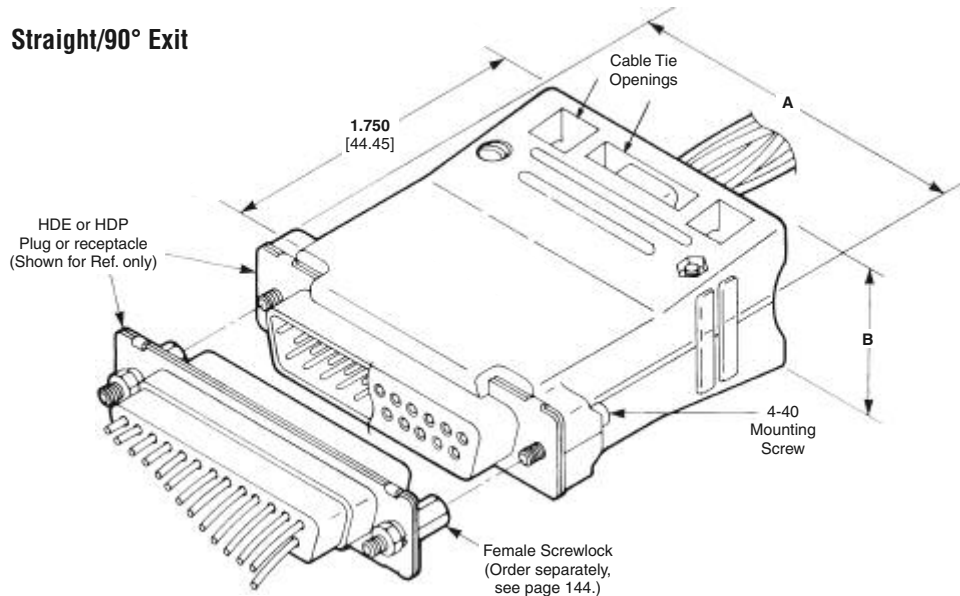

**Material and Finish:**

**Cable Clamp Housing—**  
Thermoplastic, gray

**4-40 Mounting Screws—**  
Steel, zinc plated

**4-40 Housing Screws & Hex Nuts—**  
Steel, zinc plated

**Related Product Data:**

**Connectors used with:**  
**HDE All-Plastic—**pages 112 & 113  
**HDE Metal-Shell—**pages 114 & 115  
**HDP Metal-Shell—**pages 90-102

**Other accessory capabilities:**  
**Spring Latches (Two Piece)—**  
page 152

**Technical Documents:**

**Instruction Sheet—**408-7555

Shell Size	Dimensions		Cable Dia. (Max.)	Cable Clamp Kit No.
	A	B		Individual
2	1.550	.826	.350	5206471-1
	39.37	20.98	8.89	
3	2.090	.826	.335	5206472-1
			8.51	
			.460	
11.68	5745134-1			
4	2.738	.826	.675	5745081-1
			17.15	
5	2.644	.938	.775	5745082-1
			19.69	
67.16	23.83			

- Notes:**
1. All parts are packaged unassembled.
  2. Straight or 90° cable exit is achieved by inserting AMP-TY Cable Ties through cable tie openings and clamping the cable to one housing half only.

**Note:** All part numbers are RoHS compliant.

**Unshielded Cable Clamps** (Continued)

The TE Quik-Snap Backshell Kit is a one-piece, all-plastic cable clamp kit designed for use with either the AMPLIMITE HDP-20, HDP-22, or HDE, all-plastic or metal-shell connectors.

Kits are available for connector sizes 1, 2, 3, and 4 with a cable exit option of 180° or 120°.

**Each kit contains:**

- 1-Hinged, plastic clamp
- 2-Self-tapping screws
- 1-Strain relief clip
- 1-Cable exit gate plug (Used to close unused exit)

(For metal-shell connector applications an optional kit with 2 retainer clips and screws is available.)

**Material and Finish:**

**Cover**—Polypropylene, black

**Strain Relief Clip**—Stainless steel

**Retainer Clip**—Stainless steel

**Screws**—Carbon steel, zinc plated

**Cable Gate**—Polypropylene, Black

**Related Product Data:**
**Connectors used with:**

**HDP Metal-Shell**—pages 90-102

**HDE All-Plastic**—pages 112 & 113

**HDE Metal-Shell**—pages 114 & 115

**Technical Documents:**

**Instruction Sheet**—408-7837

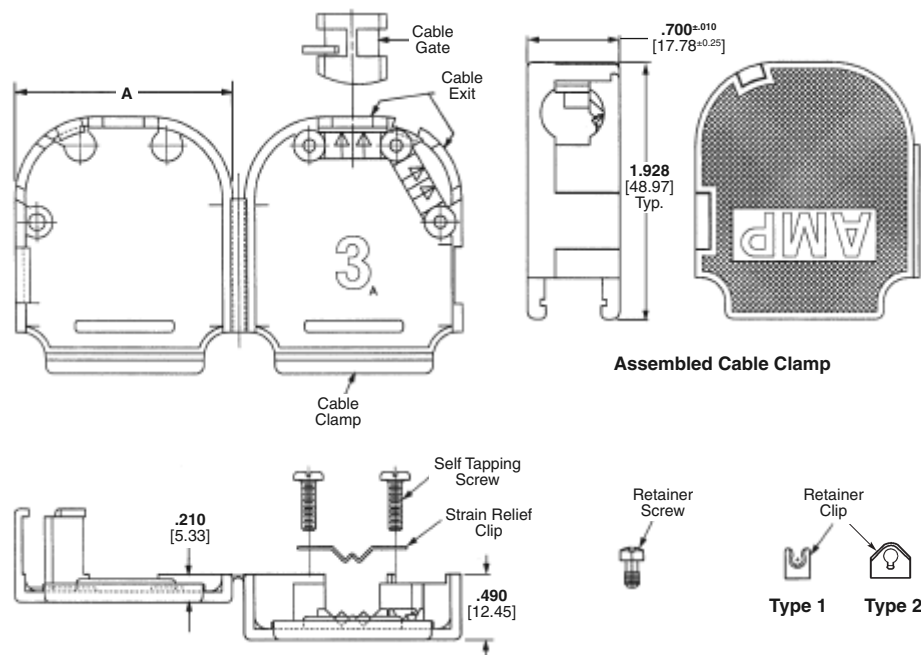
**One-Piece, All-Plastic Cable Clamp for Jacketed Cable, 180°/120° Exit (HDP and HDE) (Quik-Snap)**

Shell Size	Cable Dia. Range (Ref.)	Dimension A	Kit Number* with Retainer Screws and Clips	Kit Number*** without Retainer Screws and Clips	Packaging
1	.075-.250 1.91-6.35	.785 19.94	5749914-1	—	Bulk Pkg.
			5749914-2	5750100-1	Unit Kit
			5749914-4**	—	Unit Kit
3	.180-.460 4.57-11.68	1.650 41.91	5749626-2	5750078-1	Unit Kit
			5749916-2	—	Bulk Pkg.
4	.250-.550 6.35-13.97	2.285 58.04	5749916-2	—	Unit Kit

\*For metal-shell connectors only.

\*\*Type 2 Retainer Clip

\*\*\*For Metal-Shell or All-Plastic Connectors

**Note:** All part numbers are RoHS compliant.

## Unshielded Cable Connector and Clamp Kits

The AMPLIMITE Quik-Snap Backshell and Connector kit presents a complete package for your unshielded subminiature D connector needs. Kits are available for Shell Sizes 1, 2 and 3, and are packaged 25 and 100 kits per unit.

### One-Piece, All-Plastic Cable Clamp for Jacketed Cable, 180°/120° Exit and HDP-20 and HDE-20 Connector

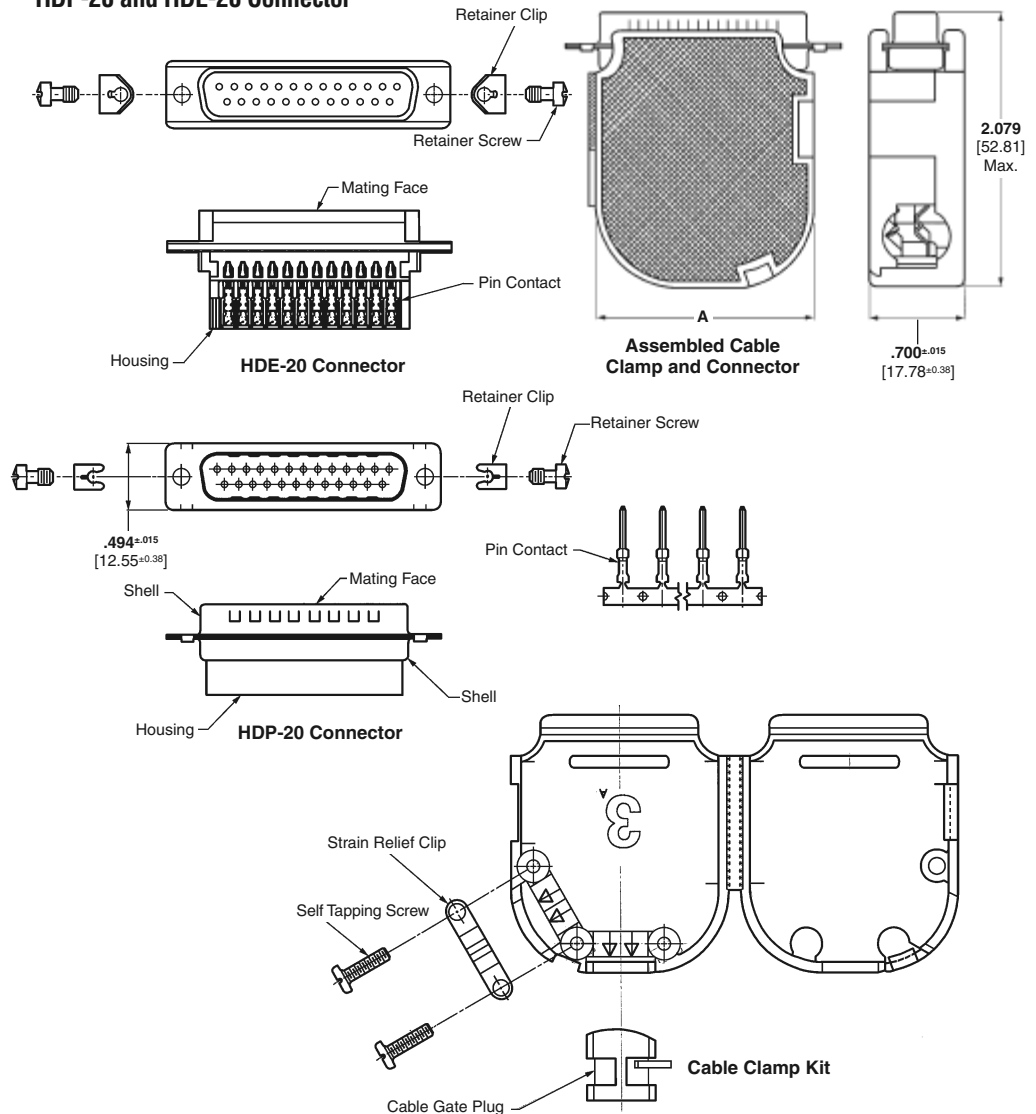

#### Each kit contains:

- 1-Hinged Plastic Clamp
- 2-Retention Screws
- 2-Retention Clips
- 1-Cable Gate Plug
- 1-Strain Relief Clip
- 2-Self Tapping Screws
- 1-Connector and Contacts

#### Material and Finish:

- Cover**—Polypropylene, black
- Retention Screws**—Steel, zinc plated
- Retention Clips**—Stainless steel
- Cable Gate Plug**—Polypropylene, Black
- Strain Relief Clip**—Stainless steel
- Self Tapping Screws**—Steel, zinc plated
- Contacts**—Brass (HDP Pins), Phosphor Bronze (All Others), plated gold flash on the mating end, .000100 [0.00254] min. tin or tin on the terminating end, all over .000030 [0.00076] min. nickel underplating
- Housing**—Polyester or nylon, glass-filled, UL rated 94V-0, black
- Shell**—Steel, plated .000200 [0.00508] min. tin over .000050 [0.00127] min. copper

#### Technical Documents:

**HDE Connectors:**  
**Instruction Sheets**—  
 408-6621

**Application Specifications**—  
 114-40002  
 114-40003

**HDP Connectors:**  
**Application Specifications**—  
 114-10000  
 114-40030

**Cable Clamps:**  
**Instruction Sheet**—408-9544

**Retention Clips:**  
**Instruction Sheet**—408-7837

### Unshielded Cable Clamp Kits with HDP-20 Connectors

Shell Size	Cable Dia. Range (Ref.)	Dimension A	Plug Kit Part No.	Receptacle Kit Part No.	Packaging
1	.075-.250 1.91-6.35	.785 19.94	749808-8	749812-7	100/pack
2	.170-.380 4.32-9.65	1.110 28.19	749808-9	—	100/pack
3	.180-.460 4.58-11.68	1.650 41.91	749808-7	1-749812-1	100/pack

### Unshielded Cable Clamp Kits with HDE-20 All-Plastic Connectors

Shell Size	Cable Dia. Range (Ref.)	Dimension A	Plug Kit Part No.	Receptacle Kit Part No.	Packaging
3	.180-.460 4.58-11.68	1.650 41.91	749809-9	749813-8	100/pack

**Note:** All part numbers are RoHS compliant.

## Unshielded Cable Clamps

Low Profile Cable Clamps feature a two-piece construction which allows the two cover halves to be snapped together, no hardware is required for assembly. They can be used on plugs or receptacles and will not interfere with commonly used mating hardware. Sufficient Cable Support Gates (or a Cable Support Gate Latch) are supplied with each cable clamp kit to achieve adjustable clamping over a wide range of jacketed cable diameters.

### Material

Black thermoplastic

### Related Product Data:

#### Connectors used with:

**HDE All-Plastic**—pages 112 & 113

**HDE Metal-Shell**—pages 114 & 115

#### Other accessory capabilities:

**Male Screw Retainers**—

pages 146 & 147

**Female Screwlocks**—page 148

**Locking Posts and Slide Latches**—

pages 149-151

**Latching Blocks**—pages 153 & 154

### Straight Exit Low Profile for Jacketed Cable

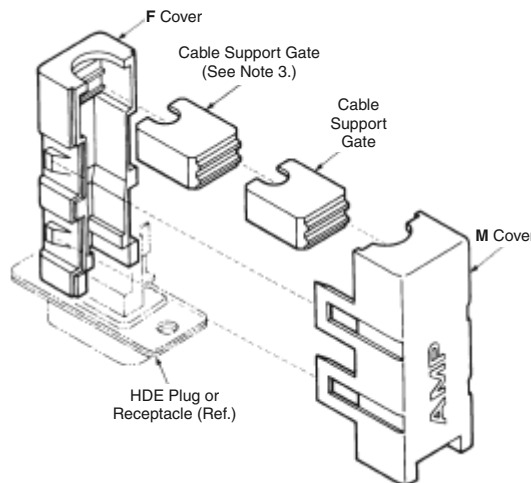
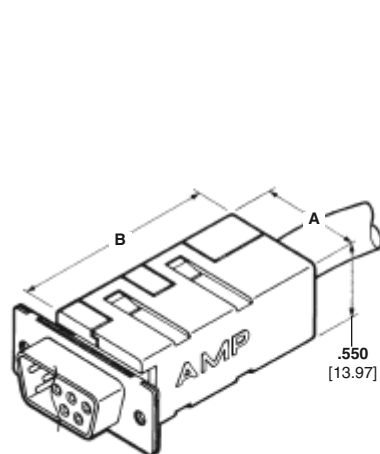

Shell Size	Dimensions		Cable Dia. (Max.)	Cable Clamp Kit No.	
	A	B		Individual	Bulk Packed*
1	.732 18.59	When used On Plug: 1.582 40.18 When used on Receptacle: 1.533 38.94	.330 8.38	745547-1	745547-2
2	1.056 26.82	When used On Plug: 1.582 40.18 When used on Receptacle: 1.533 38.94	.425 10.80	745553-1	745553-2
3	1.604 40.74	When used On Plug: 1.700 43.18 When used on Receptacle: 1.651 41.94	.550 13.97	745560-1	745560-2

\*Each part is individually bulk packed for multiple kit orders.

**Notes:** 1. All parts are packaged unassembled.

2. Each kit is comprised of two cover halves (F and M) and an assortment of cable support gates.

3. Cable support gate must be used as shown for small diameter cable.

### 90° Exit Low Profile for Jacketed Cable

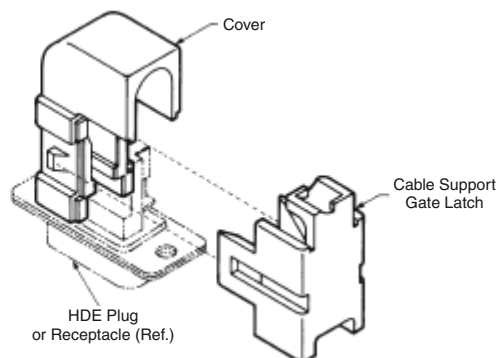
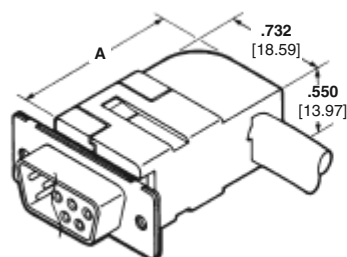

Shell Size	Dimension A		Cable Dia. (Max.)	Cable Clamp Kit No.
	When used on Plug	When used on Receptacle		Individual
1	1.290 32.77	1.241 31.52	.330 8.38	745550-1

**Notes:** 1. All parts are packaged unassembled.

2. Each kit is comprised of a cover half and an assortment of cable support gate latches.

**Note:** All part numbers are RoHS compliant.

## Unshielded Cable Clamps (Continued)

### Material

Black thermoplastic

### Slide-On Back Covers

#### Related Product Data:

##### Connectors used with:

**HDE All-Plastic**—pages 112 & 113

**HDE Metal-Shell**—pages 114 & 115

##### Other accessory capabilities:

**RFI/EMI Metal Shields**—  
pages 141 & 142

**Male Screw Retainers**—  
pages 146 & 147

**Locking Posts and Slide Latches**—  
pages 149-151

**Latching Blocks**—pages 153 & 154

#### Technical Documents:

**Instruction Sheet**—408-6658

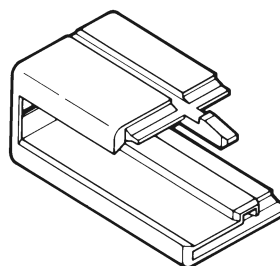
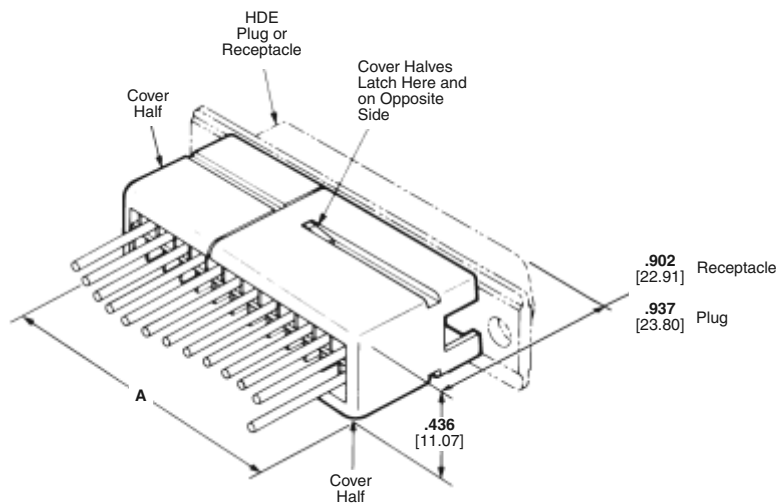

**Back Cover Half**  
(See Note 2.)

Shell Size	Dim. A	Back Cover Kit No. Individual
1	.610 15.49	745530-1
2	.934 23.72	745530-2
3	1.482 37.64	745530-3
4	2.134 54.20	745530-4

- Notes:** 1. All parts are packaged unassembled.  
2. Each slide-on back cover kit includes two identical cover halves which snap together over the connector.

**Note:** All part numbers are RoHS compliant.

## Unshielded Cable Clamps (Continued)

Box and Lid Cable Clamps can be used on either plugs or receptacles and will not interfere with commonly used hardware. Their hinged construction allows easy assembly to a harness. A wide range of cable diameters are accommodated through the use of cable support gates, supplied with each cable clamp.

Cable clamps are available in kits with appropriate hardware for convenient plug/receptacle mating. See below for kits with Male Screw Retainers.

### Box and Lid Straight/90° Exit



Shell Size 1 & 2

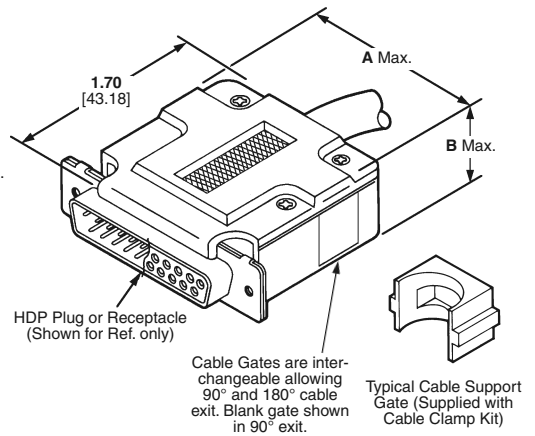

Shell Size 3 & 4 & 5

### Material and Finish:

**Cable Clamp Housing**—Thermoplastic, black with textured finish

**Gates**—Thermoplastic, black

**Flat Head Screws**—Steel, black, zinc plated

### Related Product Data:

**Connectors used with:**  
**HDP Metal-Shell**—pages 90-102

**Other accessory capabilities:**  
**Male Screw Retainers**—pages 146 & 147

**Female Screwlocks**—page 148

**Locking Posts and Slide Latches**—pages 149-151

**Spring Latches (Two Piece)**—page 152

**Latching Blocks**—pages 153 & 154

### Technical Documents:

**Instruction Sheet**—408-7555

### Material and Finish:

**Cable Clamp Housing**—Thermoplastic, black with textured finish

**Gates**—Thermoplastic, black

**Flat Head Screws**—Steel, black, zinc plated

**Male Screw**—Steel, zinc plated yellow chromate

**Retaining Clip**—Stainless steel

### Related Product Data:

**Connectors used with:**  
**HDP Metal-Shell**—pages 90-102

### Technical Documents::

**Instruction Sheets**—  
408-7555  
408-7837

Shell Size	Dimensions		Cable Dia. Max. (Ref.)		Cable Clamp Kit No.	
	A	B	Straight Cable Exit	90° Cable Exit	Individual	Bulk Packed*
1	.755 19.18	.630 16.00	.160 4.06	.160 4.06	207467-1	207467-2
2	1.078 27.38	.630 16.00	.320 8.13	.320 8.13	207470-1	—
3	1.620 41.15	.770 19.56	.390 9.91	.390 9.91	207345-1	207345-2
4	2.268 57.61	.770 19.56	.640 16.26	.405 10.29	207473-1	207473-2
5	2.178 55.32	.880 22.35	.490 12.45	.490 12.45	207476-1	—

\*Each part is individually bulk packed for multiple kit orders.

- Notes:**
1. All parts are packaged unassembled.
  2. Cable diameter is adjustable by changing cable support gates. Use the flat side of cable support gates for discrete wire, and the semicircle side for jacketed cable.
  3. Cable clamp assemblies are available in kits with male screw retainers, see below.

### Box and Lid Straight/90° Exit Cable Clamp Kits with Male Screw Retainers



Shell Size 1 & 2

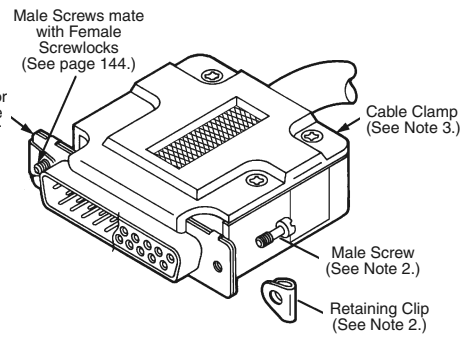

Shell Size 3 & 4 & 5

Shell Size	Cable Clamp Kit No.
1	5207908-1
2	5207908-4
3	5207908-7
4	1-5207908-0
5	1-5207908-3

- Notes:**
1. All parts are packaged unassembled.
  2. Each kit is comprised of a cable clamp and male screw retainer hardware (2 each). Male screw retainers are also available in kit form, see page 146.
  3. For ordering cable clamps separately, see above.

**Note:** All part numbers are RoHS compliant.



**Unshielded Cable Clamps (Continued)**

Cable Connectors

Straight/45° Exit Cable Clamps can be used on either a plug or receptacle and will not interfere with commonly used hardware, such as Male Screw Retainers, Female Screw-locks or Spring Latches and Latching Blocks. Their hinged construction allows easy assembly to a harness. Also, the straight or 45° angle of the cable exit is achieved by merely positioning the Cable Support Gate for the desired angle prior to installing the assembly onto the plug or receptacle. Adjustable screws are used to tighten cable strain reliefs.

Cable Clamp assemblies are available in kits with appropriate hardware for convenient plug/receptacle mating.

**Material and Finish:**

- Cable Clamp Housing**—Thermoplastic, black with textured finish
- Gates**—Thermoplastic, black
- Pan Head Screws, 6-32 Set Screw and 6-32 Square Nut**—Steel, zinc plated (sizes 1 and 2 include self-tapping screws only)

**Related Product Data:**

- Connectors used with:**  
**HDP Metal-Shell**—pages 90-102
- Other accessory capabilities:**  
**Male Screw Retainers**—pages 146 & 147
- Female Screwlocks**—page 148
- Locking Posts and Slide Latches**—pages 149-151
- Spring Latches (Two Piece)**—page 152
- Latching Blocks**—pages 153 & 154

**Technical Documents:**

**Instruction Sheet**—408-7555

**Material and Finish:**

- Cable Clamp Housing**—Thermoplastic, black with textured finish
- Gates**—Thermoplastic, black
- Pan Head Screws, 6-32 Set Screw and 6-32 Square Nut**—Steel, zinc plated (sizes 1 and 2 include self-tapping screws only)
- Male Screw**—Steel, zinc plated yellow chromate
- Retaining Clip**—Stainless steel

**Related Product Data:**

**Connectors used with:**  
**HDP Metal-Shell**—pages 90-102

**Technical Documents:**

**Instruction Sheets**—408-7555  
408-7837

**Note:** All part numbers are RoHS compliant.

**Clam Shell Straight/45° Exit**



Shell Size	Dimensions				Cable Dia. (Max.)	Short Cable Clamp Part No.		Standard Cable Clamp Part No.	
	A	B	C	D		Individual	Bulk Packed*	Individual	Bulk Packed*
1	1.625	.750	.640	.640	.256	—	—	5205729-1	5205729-3
	41.28	19.05	16.26	16.26	6.30	—	—	—	—
2	1.250	1.073	.600	.640	.320	5206393-1	—	—	—
	31.75	27.25	15.24	16.26	8.13	—	—	5205730-1	5205730-3
3	1.625	1.073	.640	.640	.320	—	—	5205730-1	5205730-3
	41.28	27.25	16.26	16.26	8.13	—	—	—	—
3	1.250	1.615	.600	.640	.420	5206390-1	5206390-3	—	—
	31.75	41.02	15.24	16.26	10.67	—	—	5205718-1	5205718-4
4	1.625	1.615	.640	.640	.420	—	—	5205718-1	5205718-4
	41.28	41.02	16.26	16.26	10.67	—	—	—	—
4	1.625	2.263	.640	.640	.490	—	—	5205731-1	—
	41.28	57.48	16.26	16.26	12.45	—	—	—	—

\*Each part is individually bulk packed for multiple assembly orders.

- Notes:**
1. All parts are packed unassembled.
  2. Quantity of pan head screws supplied with cable clamp assembly varies with shell size.
  3. Cable clamps are available in kits with male screw retainers, see below.
  4. All pan head screws have combination cross-recessed and slotted heads.

**Clam Shell Straight/45° Exit Cable Clamp Kits with Male Screw Retainers**



Shell Size	Short Cable Clamp Kit No.		Standard Cable Clamp Kit No.	
	Individual	Bulk Packed*	Individual	Bulk Packed*
1	—	—	5206478-1	—
2	—	—	5206478-2	—
3	1-5206478-2	2-5206478-6	5206478-3	2-5206478-2
4	—	—	5206478-4	—
5	—	—	5206478-5	—

\*Each part is individually bulk packed for multiple assembly orders.

- Notes:**
1. All parts are packaged unassembled.
  2. Each kit is comprised of a cable clamp and male screw retainer hardware (2 each). Male screw retainers are also available in kit form, see page 146.
  3. For ordering cable clamps separately, see above.

## Unshielded Cable Clamps (Continued)

**Material and Finish:**

- Cable Clamp Housing**—Nylon, black
- 4-40 Fillister Head Screws & Hex Nuts**—Steel, clear zinc plated
- Jackscrews**—Steel, black zinc plated

**Related Product Data:**

- Connectors used with:**
- HDP Metal-Shell**—pages 90-102

**Straight Exit Dataphone**

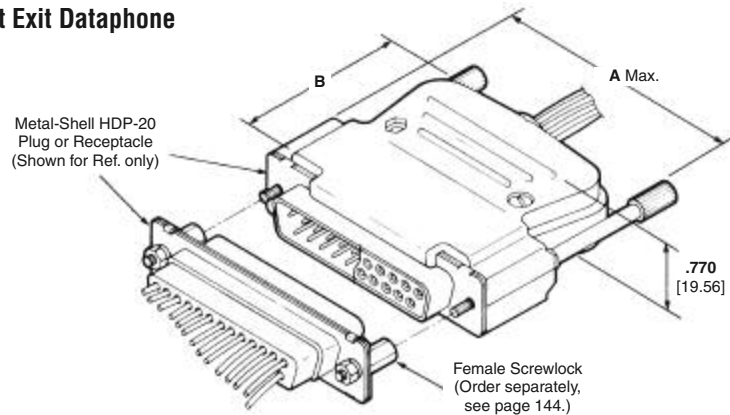

Shell Size	Dimensions		Max. Cable Dia. (without Gate)	Max. Cable Dia. (with Gate)	Cable Gate Identification*	Thread Size	Cable Clamp Kit No.
	A	B					
2	1.575 40.01	1.312 33.32	.400 10.16	.200 5.08	2A	4-40	5745122-2
				.260 6.60	2B		
				.320 8.13	2C		
3	2.115 53.72	1.421 36.09	.500 12.70	.250 6.35	3A	4-40	5745121-2
				.340 8.64	3B		
				.420 10.67	3C		

\*Molded-in identification (as shown in chart above) is provided on cable support gates to facilitate proper selection with regard to shell size and maximum acceptable cable diameter.

- Notes:**
1. All parts are packaged unassembled.
  2. Cable diameter is adjustable by changing cable support gates.

**Straight Exit for Jacketed Cable (Two-Piece)**

This cable clamp allows cable to be fully prepared and terminated before the clamp is installed.

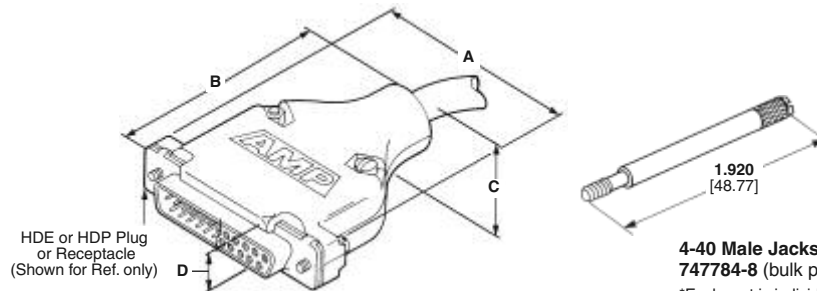

**4-40 Male Jackscrew Kit Nos.: 747784-8 (bulk packed)\*†**

\*Each part is individually bulk packed for multiple kit orders.  
†Slotted for screwdriver use.

**Material and Finish:**

- Cable Clamps**—ABS black
- 4-40 Fillister Head Screws and Hex Nuts**—Steel, zinc plated
- 4-40 Mounting Screws**—Steel, zinc plated
- Jackscrews**—Stainless steel, passivated

**Related Product Data:**

- Ferrules**—pages 143-145
- Connectors used with:**
- HDE Metal-Shell**—pages 114 & 115
- HDP Metal-Shell**—pages 90-102
- Other accessory capabilities:**
- Spring Latch (Two-Piece)**—page 152

**Cable Clamp Kits with Grommets**

Shell Size	Dimensions				Cable O.D. Range	No. of Grommets Per Set	Kit Numbers
	A	B	C	D			
1	1.215 30.86	1.910 48.51	.570 14.48	.630 16.00	.185-.320 4.70-8.13	4	5748678-1
2	1.545 39.24	1.910 48.51	.620 15.75	.620 15.75	.185-.320 4.70-8.13	4	5748678-2
3	2.090 53.09	1.920 48.77	.680 17.27	.640 16.26	.255-.470 6.48-11.94	6	5748678-3
4	2.738 69.55	1.920 48.77	.800 20.32	.620 15.75	.255-.470 6.48-11.94	6	5748678-4
5	2.644 67.16	1.920 48.77	.900 22.86	.730 18.54	.255-.470 6.48-11.94	6	5748678-5

- Notes:**
1. All parts are packaged unassembled.
  2. Jackscrews must be purchased separately.
  3. Split-ring and crimp ferrules are shown on pages 143-145.
  4. Shielded cable clamps will not accept connector housings with clinch nuts.

**Note:** All part numbers are RoHS compliant.

**Technical Documents:**

- Instruction Sheet**—408-6609

**Unshielded Cable Clamps** (Continued)

Cable Connectors

Straight/90° Exit Cable Clamps can be used on a plug or receptacle and will not interfere with commonly used mating hardware. Their three-piece construction allows easy assembly to a cable harness. Also, the same cable clamp components are used for both straight and 90° cable exit applications. This is accomplished by simply positioning the Male and Female Panels on the Yoke for the desired angle.

**Material**

Black thermoplastic

**Related Product Data:**

**Connectors used with:**

**HDE All-Plastic**—pages 112 & 113

**HDE Metal-Shell**—pages 114 & 115

**HDP Metal-Shell**—pages 90-102

**Other accessory capabilities:**

**Female Screwlocks**—page 148

**Locking Posts and Slide Latches**—pages 149-151

**Latching Blocks**—pages 153 & 154

**Straight/90° Exit**



**Straight Cable Exit Application**



**90° Cable Exit Application**



**Typical Cable Support Gate**  
(Supplied with Cable Clamp Kit)

Shell Size	Cable Clamp Configuration	Dimensions		Cable Dia.	Cable Clamp Kit No. Individual
		A	B		
3	Straight Exit	1.906	1.672	.550	745306-1
	90° Exit	2.066	1.396		
4	Straight Exit	2.424	1.820	.750	745311-1
	90° Exit	2.638	1.596		

- Notes:**
1. All parts are packaged unassembled.
  2. Each cable clamp assembly includes a yoke, male panel, female panel and four cable support gates. The cable diameter is adjustable by changing the cable support gates.

**Note:** All part numbers are RoHS compliant.

## Shielded Cable Clamps

### Straight Exit RFI/EMI Shields for Jacketed Cable (Two-Piece)

This RFI/EMI shield allows cable to be fully prepared and terminated to the connector before the shield is installed. During installation, the shield of the jacketed cable is folded back and compressed into the cable opening of the RFI/EMI shield. For greater cable support and/or shielding effectiveness, split-ring and crimp ferrules are available (pages 143-145).

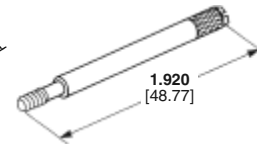
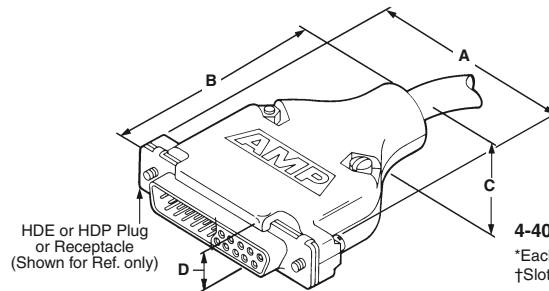

**4-40 Male Jackscrew Kit Nos.: 747784-8 (bulk packed)\*†**  
 \*Each part is individually bulk packed for multiple kit orders.  
 †Slotted for screwdriver use.

### Material and Finish:

- Die Cast Shield**—Zinc alloy, plated bright nickel over bright copper
- Metal-Plated Plastic Shield**—Thermoplastic, plated nickel over copper
- 4-40 Fillister Head Screws and Hex Nuts**—Steel, zinc plated
- 4-40 Mounting Screws**—Steel, zinc plated
- Jackscrews**—Stainless steel, passivated

### Related Product Data:

- Ferrules**—pages 143-145
- Connectors used with:**
- HDE Metal-Shell**—pages 114 & 115
- HDP Metal-Shell (Tin plated only)**—pages 90-102
- Other accessory capabilities:**
- Spring Latch (Two-Piece)**—page 152

### Technical Documents:

- Product Specification**—108-40032
- Instruction Sheet**—408-6609

Shell Size	Dimensions				Cable O.D. (Max.)	Die Cast Shield Kit Numbers	Metal-Plated Plastic Shield Kit Numbers	Grommet Sets		Part Number
	A	B	C	D				Cable O.D. Range	No. of Grommets Per Set	
1	1.215 30.86	1.910 48.51	.550** 13.97	.620** 15.75	.200 5.08	5745171-2	5745854-5	—	—	—
					.250 6.35	5745171-1	5745854-3	—	—	—
					.370 9.40	5745171-5	5745854-1	.185-.320 4.70-8.13	4	747746-1
					.225 5.72	5745172-3	5747099-7	—	—	—
2	1.545 39.24	1.910 48.51	.620 15.75	.620 15.75	.300 7.62	5745172-2	5747099-5	—	—	—
					.375 9.53	5745172-1	5747099-3	.185-.320 4.70-8.13	4	747746-1
					.430 10.92	1-5745172-3	5747099-1	—	—	—
					.280 7.11	5745173-5	5745833-9	—	—	—
3	2.090 53.09	1.920 48.77	.680 17.27	.620** 15.75	.350 8.89	5745173-4	5745833-7	—	—	—
					.430 10.92	5745173-3	5745833-5	—	—	—
					.480 12.19	5745173-2	5745833-4	—	—	—
					.530 13.46	5745173-1	5745833-1	.255-.470 6.48-11.94	6	747973-1
4	2.738 69.55	1.920 48.77	.800 20.32	.620 15.75	.350 8.89	5745174-5	5747100-9	—	—	—
					.425 10.80	5745174-4	5747100-7	—	—	—
					.500 12.70	5745174-3	—	—	—	—
					.530 13.46	2-5745174-7	—	.255-.470 6.48-11.94	6	747973-1
5	2.644 67.16	1.920 48.77	.900 22.86	.730 18.55	.575 14.61	5745174-2	5747100-3	—	—	—
					.650 16.51	5745174-1	5747100-1	—	—	—
					.375 9.53	5745175-6	—	—	—	—
					.450 11.43	5745175-5	—	—	—	—
5	2.644 67.16	1.920 48.77	.900 22.86	.730 18.55	.525 13.34	5745175-4	—	.255-.470 6.48-11.94	6	747973-1
					.600 15.24	5745175-3	—	—	—	—
					.675 17.15	5745175-2	—	—	—	—
					.750 19.05	5745175-1	5747098-1	—	—	—

### Cable Clamp Kits with Grommets

Shell Size	Dimensions				Cable O.D. Range	No. of Grommets Per Set	Kit Numbers	
	A	B	C	D			Die Cast Shield With Grommets	Metal-Plated Plastic Shield With Grommets
1	1.215 30.86	1.910 48.51	.550** 13.97	.620** 15.75	.185-.320 4.70-8.13	4	5748676-1	5748677-1
2	1.545 39.24	1.910 48.51	.620 15.75	.620 15.75	.185-.320 4.70-8.13	4	5748676-2	5748677-2
3	2.090 53.09	1.920 48.77	.680 17.27	.620** 15.75	.255-.470 6.48-11.94	6	5748676-3	5748677-3
4	2.738 69.55	1.920 48.77	.800 20.32	.620 15.75	.255-.470 6.48-11.94	6	5748676-4	5748677-4
5	2.644 67.16	1.920 48.77	.900 22.86	.730 18.54	.255-.470 6.48-11.94	6	5748676-5	5748677-5

- Notes:**
- All parts are packaged unassembled.
  - Jackscrews must be purchased separately.
  - Split-ring and crimp ferrules are shown on pages 143-145.
  - Shielded cable clamps will not accept connector housings with clinch nuts.

\*\* The following dimensions apply to metal-plated plastic cable clamps: Size 1: C = .570 [14.48], D = .630 [16.0]  
 Size 3: D = .640 [16.26]

**Note:** All part numbers are RoHS compliant.

Both the straight exit and the 90° exit die cast RFI/EMI shield allows cable to be fully prepared and terminated to the connector before the shield is installed. During installation, the shield of the jacketed cable is folded back and compressed into the cable opening of the RFI/EMI shield. For greater cable support and/or shielding effectiveness, splitting and crimp ferrules are available (pages 143-145).

**Straight Exit RFI/EMI Die Cast Shield for Jacketed Cable (Two-Piece)**

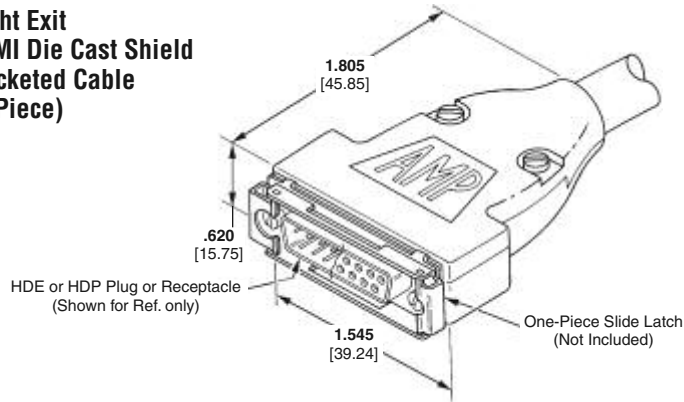

**Material and Finish:**

**Shield**—Zinc alloy, plated nickel over copper

**4-40 Pan Head Screws & Latch Screws (90° Exit Only)**—Steel, zinc plated

**One-Piece Slide Latch (90° Exit Only)**—Stainless steel

**Related Product Data:**

**Ferrules**—pages 143-145

**Connectors used with:**  
**HDE Metal-Shell**—pages 114 & 115  
**HDP Metal-Shell (Tin plated only)**—pages 90-102

**Technical Documents:**

**Product Specification**—108-40032  
**Instruction Sheet**—408-6769

Shell Size	No. of Positions	ID Letter	Cable Dia. w/Ferrules	Part Number	Grommet Kit
2	15	E	.260-.300 6.60-7.72	5745919-3	—
		H	.190-.375 4.83-9.53	5745919-2	747746-1*
		K	.190-.430 4.83-10.92	5745919-1	—

- \*Cable Dia. Range using Grommet is .185-.320 [4.70-8.13].  
**Notes:** 1. All parts packaged unassembled.  
 2. Each kit comprised of a two-piece shield with 2 pan head screws.  
 3. Split-ring and crimp ferrules are shown on pages 143-145.

**90° Exit RFI/EMI Die Cast Shields for Jacketed Cable (Two-Piece)**

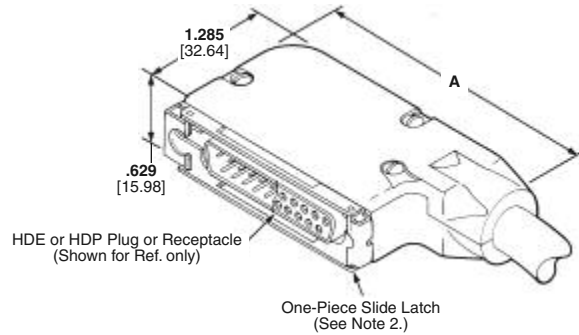

Shell Size	Dimension A	Cable Dia. w/Ferrules	Shield with Slide Latch Kit Numbers (See Note 2)	Shield without Slide Latch Kit Numbers (See Note 3)	Grommet Kit
2	2.310 58.67	.185-.225 4.70-6.48	5745652-4	—	—
		.260-.300 6.60-7.62	5745652-3	—	—
		.190-.375 4.83-9.53	5745652-2*	—	747746-1
		.190-.430 4.83-10.92	5745652-1	—	—
		.240-.280 6.10-7.11	5745653-5	—	—
		.315-.355 8.00-9.02	5745653-4	—	—
3	2.850 72.39	.190-.430 4.83-10.92	5745653-3	5747194-3	—
		.440-.480 11.18-12.19	5745653-2	—	—
		.380-.530 9.65-13.46	5745653-1*	—	747973-1

- \* Cable Dia. with Grommet Kit: Size 2 = .185-.320 [4.70-8.13]; Size 3 = .255-.470 [6.48-11.94].  
**Notes:** 1. All parts are packaged unassembled.  
 2. Each kit is comprised of a two-piece shield with three pan head screws and a slide latch with two 4-40 slide latch screws.  
 3. Each kit is comprised of a two-piece shield with three pan head screws.  
 4. Split-ring and crimp ferrules are shown on pages 143-145.

**Note:** All part numbers are RoHS compliant.

## Shielded Cable Clamps (Continued)

### Material and Finish:

**Outer Ferrule**—Copper, plated  
.000100 [0.00254] min. tin  
**Inner Ferrule**—.023 [0.58] thick brass,  
plated .000050 [0.00127] tin over copper

### Related Product Data:

**Shields used with:**  
**Straight Exit**—pages 141 & 142  
**90° Exit**—page 142

### Technical Documents:

**Product Specification**—  
108-40032  
**Instruction Sheets**—  
408-9315 Hand Tool  
408-9318 Die Sets

### Crimp Ferrules for Braided Cable Shield (See pages 144 & 145 for Inner and Outer Ferrule Part Numbers.)

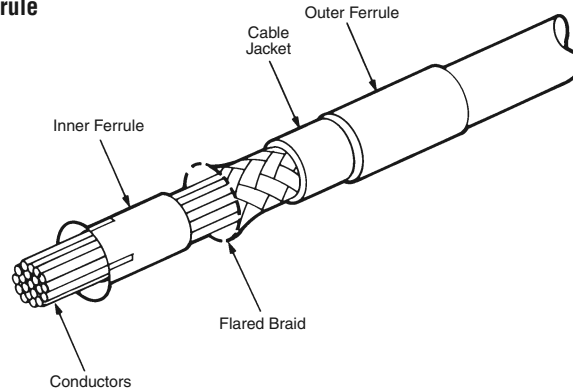

### Application Tooling

**Note:** Crimp ferrules are for use with braided shields only. Crimp ferrules require application tooling with die sets for attachment to cable.



**Pneumatic Bench Tool  
No. 312522-2  
(Requires Die Set Holder  
No. 58449-1.)**



**AMP Hand Tool No. 543344-1  
(See pages 144 & 145 for Hand Tool  
Die Set Numbers)**

### Split-Ring Ferrules for Foil or Braided Cable Shield (See pages 144 & 145 for Split-Ring Ferrule Part Numbers.)

### Material:

Aluminum

### Related Product Data:

**Shields used with:**  
**Straight Exit**—pages 141 & 142  
**90° Exit**—page 142

### Technical Document

**Product Specification**—108-40032

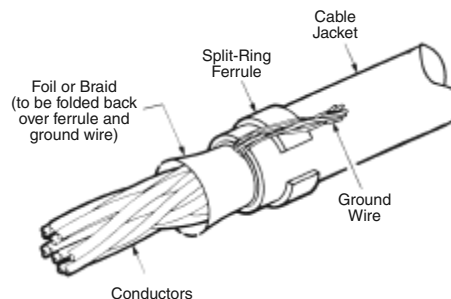

**Note:** Split-ring ferrules cannot be used with outer and inner ferrules. Split-ring ferrules are suitable for both foil and braided shields. The ferrules do not require tooling for assembly.

**Note:** All part numbers are RoHS compliant.

**Shielded Cable Clamps** (Continued)

**Crimp and Split-Ring Ferrules**

Cable Connectors

Shell Size	Cable Dia. (Max.)	← When using these Shield Kits →				← Use these Ferrules →				
		Straight Exit Shield Kit No.		90° Exit Die Cast Shield Kit No.		Split-Ring* Ferrule No.	Crimp Ferrule No. and Tooling No.**			
		Die Cast	Metal-Plated Plastic	With Slide Latch	Without Slide Latch		Inner	Outer	Die Set For Hand Tool 543344-1	Applicator Die Set
1	.200 5.08	5745171-2	5745854-5	—	—	745508-2	—	—	—	—
	.240 6.10	5745171-5	5745854-1	—	—	—	7-745129-8	3-745130-8	543013-2	813809-1
	.250 6.35	5745171-1	5745854-3	—	—	745508-3	—	—	—	—
	.280 7.11	5745171-5	5745854-1	—	—	—	7-745129-9	4-745130-5	1-543013-7	813809-7
	.370 9.40	5745171-5	5745854-1	—	—	745508-6	6-745129-9	4-745130-0	543013-6	813809-5
2	.225 5.72	5745172-3	5747099-7	5745652-4	—	745508-3	—	—	—	—
	.240 6.10	5745172-1	5747099-3	5745652-2	—	—	7-745129-8	3-745130-8	543013-2	813809-1
	.240 6.10	1-5745172-3 5745919-1	5747099-1	5745652-1	—	—	7-745129-3	3-745130-8	543013-3	813809-1
	.280 7.11	1-5745172-3 5745919-1	5747099-1	5745652-1	—	—	7-745129-8	4-745130-5	1-543013-6	813809-7
	.300 7.62	5745172-2 5745919-3	5747099-5	5745652-3	—	745508-4	—	—	—	—
	.350 8.90	1-5745172-3 5745919-1	5747099-1	5745652-1	—	—	7-745129-2	3-745130-9	543013-4	813809-2
	.365 9.27	5745172-1	5747099-3	5745652-2	—	—	6-745129-9	4-745130-0	543013-6	813809-5
	.375 9.53	5745172-1 5745919-2	5747099-3	5745652-2	—	745508-6	—	—	—	—
	.430 10.92	1-5745172-3 5745919-1	5747099-1	5745652-1	—	745508-1	7-745129-1	4-745130-1	543013-7	813809-3
	.240 6.10	5745173-3	5745833-5	5745653-3	5747194-3	—	7-745129-3	3-745130-8	543013-3	813809-1
3	.280 7.11	5745173-5	5745833-9	5745653-5	—	745508-4	—	—	—	—
	.280 7.11	5745173-3	5745833-5	5745653-3	5747194-3	—	7-745129-8	4-745130-5	1-543013-6	813809-7
	.350 8.90	5745173-4	5745833-7	5745653-4	—	745508-5	—	—	—	—
	.350 8.90	5745173-3	5745833-5	5745653-3	5747194-3	—	7-745129-2	3-745130-9	543013-4	813809-2
	.430 10.92	5745173-3	5745833-5	5745653-3	5747194-3	745508-1	7-745129-1	4-745130-1	543013-7	813809-3
	.430 10.92	5745173-1	5745833-1	5745653-1	—	—	7-745129-5	4-745130-1	543013-8	813809-3
	.480 12.19	5745173-2	—	5745653-2	—	745508-8	—	—	—	—
.530 13.46	5745173-1	5745833-1	5745653-1	—	745508-9	7-745129-4	4-745130-2	1-543013-0	813809-4	

\*For split-ring ferrules, Min. O.D. is .040 [1.02] smaller than Max. O.D.

\*\*For inner and outer ferrules, Min. O.D. is .050 [1.27] smaller than Max. O.D. At the Max. cable O.D. the Min. insulation thickness is .060 [1.52].

Continued on Page 145

**Note:** All part numbers are RoHS compliant.

**Shielded Cable Clamps** (Continued)

**Crimp and Split-Ring Ferrules** (Continued)

Shell Size	Cable Dia. (Max.)	When using these Shield Kits				Use these Ferrules				
		Straight Exit Shield Kit No.		90° Exit Die Cast Shield Kit No.		Split-Ring* Ferrule No.	Crimp Ferrule No. and Tooling No.**			
		Die Cast	Metal-Plated Plastic	With Slide Latch	Without Slide Latch		Inner	Outer	Die Set for Hand Tool 54334-1	Applicator Die Set
4	.240 6.10	5745174-4	5747100-7	—	—	—	7-745129-3	3-745130-8	543013-3	813809-1
	.280 7.11	5745174-4	5747100-7	—	—	—	7-745129-8	4-745130-5	1-543013-6	813809-7
	.350 8.90	5745174-5	5747100-9	—	—	745508-5	—	—	—	—
	.350 8.90	5745174-4	5747100-7	—	—	—	7-745129-2	3-745130-9	543013-4	813809-2
	.430 10.92	5745174-4	5747100-7	—	—	745508-1	7-745129-1	4-745130-1	543013-7	813809-3
	.500 12.70	5745174-3	—	—	—	745508-8	—	—	—	—
	.525 13.34	5745174-1	5747100-1	—	—	—	7-745129-6	4-745130-2	1-543013-1	813809-4
	.575 14.61	5745174-2	5747100-3	—	—	1-745508-0	—	—	—	—
	.650 16.51	5745174-1	5747100-1	—	—	1-745508-1	—	—	—	—
	5	.240 6.10	5745175-6	—	—	—	—	7-745129-0	3-745130-8	543013-2
.365 9.27		5745175-6	—	—	—	—	6-745129-9	4-745130-0	543013-6	813809-5
.375 9.53		5745175-6	—	—	—	745508-6	—	—	—	—
.430 10.92		5745175-4	—	—	—	—	7-745129-5	4-745130-1	543013-8	813809-3
.450 11.43		5745175-5	—	—	—	745508-7	—	—	—	—
.525 13.34		5745175-4	—	—	—	745508-9	—	—	—	—
.530 13.46		5745175-4	—	—	—	—	7-745129-4	4-745130-2	1-543013-0	813809-4
.600 15.24		5745175-3	—	—	—	1-745508-0	—	—	—	—
.650 16.51		5745175-1	5747098-1	—	—	—	1-745508-1	4-745130-3	1-543013-4	—
.675 17.15		5745175-2	—	—	—	1-745508-1	—	—	—	—
.750 19.05	5745175-1	5747098-1	—	—	1-745508-2	—	—	—	—	

\*For split-ring ferrules, Min. O.D. is .040 [1.02] smaller than Max. O.D.  
 \*\*For inner and outer ferrules, Min. O.D. is .050 [1.27] smaller than Max. O.D. At the Max. cable O.D. the Min. insulation thickness is .060 [1.52].  
**Note:** Refer to page 143 for Application Tooling for ferrules.

**Note:** All part numbers are RoHS compliant.



## Hardware

### Commoning Strip (for HDF-20 Plugs, Size 20 Pin Contacts)

**Material and Finish:**

Brass, .004 [0.10] thick, tin plated

**Part No. 206918-2**

(Continuous Strip)

**Related Product Data:**

Used with HDF-20 Plugs—  
page 126

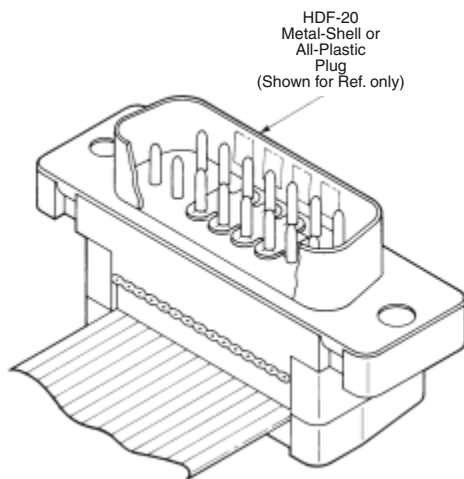

**Notes:**

1. Use punching tool to remove undesired pin commoning locations on commoning strip. Use mating receptacle to seat strip over pins in plug. Punching tool is not supplied by TE.
2. Sold in strip form, strip contains 10,000 commoning locations.

### Male Screw Retainers for Metal-Shell Connectors (HDE and HDP)

**Material and Finish:**

**Male Screw**—Steel, zinc plated clear or yellow chromate

**Retaining Clip**—.012 [0.31] stainless steel

**Related Product Data:**

**Connectors used with:**  
**HDE Metal-Shell**—pages 114 & 115  
**HDP Metal-Shell**—pages 90-102

**Technical Documents:**

**Instruction Sheet**—408-7837

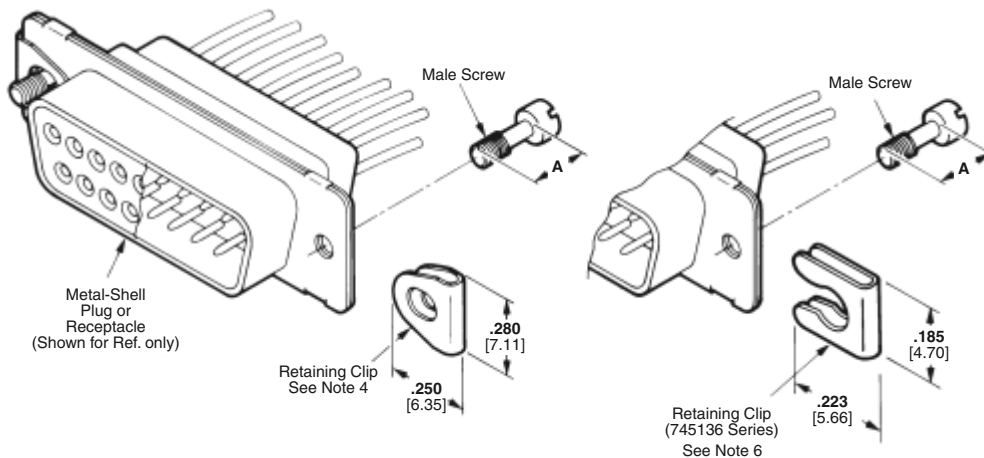

Male Screw Finish	Thread Size	Dimension A	Male Screw Retainer Kit No.	
			Individual	Bulk Packed*
Yellow Chromate	4-40	.220 5.59	5205980-1	5205980-3
		.200 5.08	5787354-1**	—
	M3 (Metric)	.225 5.72	5745136-1	5745136-2
		.200 5.08	5207871-1	—
Clear Chromate	4-40	.220 5.59	5205980-4	5205980-5
		.200 5.08	5745136-3	5745136-4

\*Each part is individually bulk packed for multiple kit orders.

\*\* Phillips Head Screw

- Notes:**
1. All parts are packaged unassembled.
  2. Each kit is comprised of two male screws and two retaining clips. Male screw retainers are also furnished as part of cable clamp kits (pages 137 and 138).
  3. Male screw retainers mate with female screwlocks (page 144), with HDF metal-shell connectors featuring 4-40 threaded inserts (page 148) and with HD metal-shell board mount connectors featuring 4-40 threaded inserts or female screwlocks.
  4. Retaining clip must be assembled onto connector flanges with threaded hole toward wire side of connector.
  5. All screws have straight slotted heads except where noted.
  6. Retaining clip must be assembled onto connector flanges with notched side of retainer toward mating side of connector.

**Note:** All part numbers are RoHS compliant.

**Hardware** (Continued)

**Material and Finish:**

**Male Screw**—Steel, zinc plated yellow chromate

**Retaining Clip**—.012 [0.51] stainless steel

**Related Product Data:**

**Connectors used with:**  
**HDE All-Plastic**—pages 112 & 113

**Technical Documents:**

**Instruction Sheet**—408-7837

**Male Screw Retainers for All-Plastic Connectors (HDE)**



**Kit Numbers:**

**745647-1** (Individually packaged, see Note 2)

**745647-2** (Bulk packed)\*

\*Each part is individually bulk packed for multiple kit orders.

**Notes:**

1. All parts are packaged unassembled.
2. Each kit is comprised of two 4-40 male screws and two retaining clips.
3. Male screw retainers mate with female screwlocks (page 148), with HDF All-Plastic connectors featuring 4-40 threaded inserts (page 125), with HD All-Plastic board mount connectors featuring integral standoffs with 4-40 threaded inserts and female screwlocks.
4. Retaining clips must be assembled onto connector flanges with threaded hole toward wire side of connector.

**Material and Finish:**

**Male Screw**—Steel, zinc plated clear chromate

**Retaining Clip**—.012 [0.51] stainless steel

**Related Product Data:**

**Connectors used with:**  
**HDF Metal-Shell and All-Plastic**—pages 125 & 126

**Technical Documents:**

**Instruction Sheet**—408-7837

**Male Screw Retainers for Metal-Shell and All-Plastic Connectors (HDF)**



**Kit Numbers:**

**746881-1** (Individually packaged, see Note 2)

**746881-2** (Bulk packed)\*

\*Each part is individually bulk packed for multiple kit orders.

**Notes:**

1. All parts are packaged unassembled.
2. Each kit is comprised of two male screws and two retaining clips.
3. Male screw retainers mate with female screwlocks (page 148), and with HD board mount connectors featuring female screwlocks.
4. Retaining clips must be assembled onto connector flanges with threaded hole toward wire side of connector.

**Note:** All part numbers are RoHS compliant.

**Hardware** (Continued)

**Material and Finish:**

**All Parts**—Cold rolled steel, zinc plated clear or yellow chromate

**Related Product Data:**

**Connectors used with:**  
**HDE Metal-Shell or All-Plastic**—pages 112-115  
**HDF Metal-Shell or All-Plastic**—pages 125 & 126  
**HDP Metal-Shell**—pages 90-102  
**HD Board Mount**—pages 54-71, 78-85, 87-89

**Technical Documents:**

**Instruction Sheet**—408-7837

**Female Screwlocks for Metal-Shell and All-Plastic Connectors (HDE, HDF, HDP)**

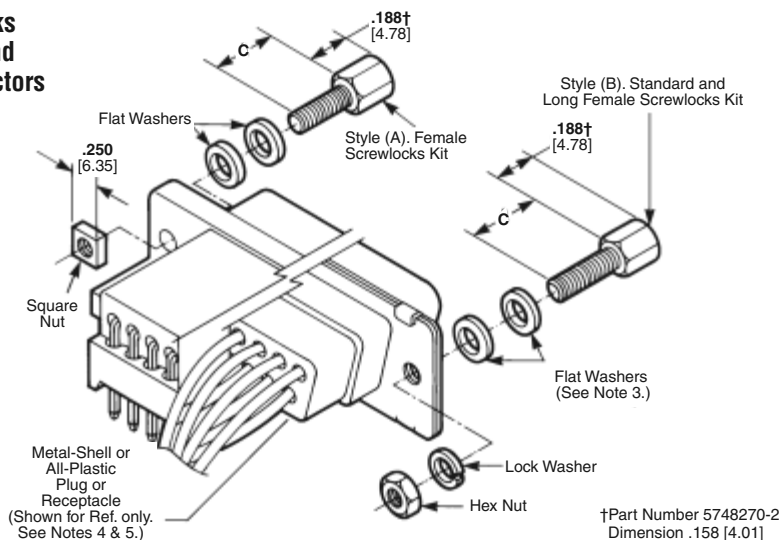

Connector Used with	Style	Dimension C	Thread Size	Finish	Kit Number	
					Individual	Bulk Packed <sup>Δ</sup>
HD All-Plastic Right-Angle Plugs and Receptacles	(A)	.250 6.35	4-40	Yellow Chromate	5207952-1	—
				Clear Chromate	5207952-3	—
HDE Metal-Shell or All-Plastic Plugs and Receptacles	(B)	.250 6.35	4-40	Yellow Chromate	5745563-1	5745563-1
				Clear Chromate	5745563-3	5745563-4
HDP or HDF Metal-Shell or All-Plastic Plugs and Receptacles	(B)	.312 7.93	4-40	Yellow Chromate	5205817-1	5205817-2
				Clear Chromate	5205817-3	5205817-4
			M3 (Metric)	Yellow Chromate	5207872-1	—
				Clear Chromate	5207872-3	—
HD or HDF All-Plastic Plugs and Receptacles with Integral Standoffs	(B)	.560 14.22	4-40	Yellow Chromate	5207719-1	5207719-2
				Clear Chromate	5207719-3	5207719-4
			2-56*	Clear Chromate	5747223-3	—

\* 2-56 is the male thread size. The female thread size is 4-40.

<sup>Δ</sup> Each part is individually bulk packed for multiple kit orders.

- Notes:**
1. All parts are packaged unassembled.
  2. Each female screwlock kit is comprised of two assemblies as illustrated above.
  3. One or two flat washers may be required for panel thicknesses less than .060 [1.52]. Female screwlocks are not recommended for panel thicknesses greater than .060 [1.52].
  4. Female screwlocks with 2-56 thread size are to be used with cable clamps with mounting flanges. Female screwlocks with 4-40 and M3 (Metric) thread sizes can be used with all other cable clamps.
  5. Female screwlocks mate with male screw retainers (pages 146 and 147).
  6. Short female screwlocks cannot be used with HDF connectors (pages 125 & 126)

**Individual Screwlocks**

(Washers and Nuts not included)

Connector Used with	Style	Dimension C	Thread Size	Finish	Screwlocks	
					Individual	Bulk Packed <sup>Δ</sup>
HD All-Plastic Right-Angle Plugs and Receptacles	(A)	.250 6.35	4-40	Yellow Chromate	5207953-2	—
				Clear Chromate	5207953-3	—
				Clear Chromate	—	5205818-3 <sup>ΔΔ</sup>
HDP or HDF Metal-Shell or All-Plastic Plugs and Receptacles	(B)	.312 7.93	4-40	Clear Chromate	5748558-3	5748558-4
				Yellow Chromate	5748270-2	5205818-2 <sup>ΔΔ</sup>
			M2.6** (Metric)	Clear Chromate	5749765-3	—
				M3*** (Metric)	Clear Chromate	5747404-3
(Special)	.185 4.70	4-40	Clear Chromate	5747877-3	—	

<sup>Δ</sup> Each part is individually bulk packed for multiple kit orders.

<sup>ΔΔ</sup>With captivated star washer. No additional hardware included.

†Part No. 5748270-2 Dimension .158 [4.01]

\*\*M2.6 is the female thread size. The male thread size is 4-40.

\*\*\*M3 is the female thread size. The male thread size is 4-40.

**Note:** All part numbers are RoHS compliant.



**Nut Driver, Part No. 811262-1**

(Used for assembling female screwlocks to connector flange)

**Hardware** (Continued)

**Slide Latches**

**Material and Finish:**

**4-40 Screws, Washers and Hex Nuts**—Steel, zinc plated yellow chromate

**2-56 Screws, Washers and Hex Nuts**—Steel, zinc plated clear chromate

**Slide Latch**—Stainless steel

**Related Product Data:**

**Connectors used with:**

**HDE Metal-Shell or All-Plastic**—pages 112-115

**HDF Metal-Shell or All-Plastic**—pages 125 & 126

**HDP Metal-Shell**—pages 90-102

**HD Board Mount**—pages 54-71, 78-85, 87-89

**Technical Documents:**

**Instruction Sheet**—408-6551

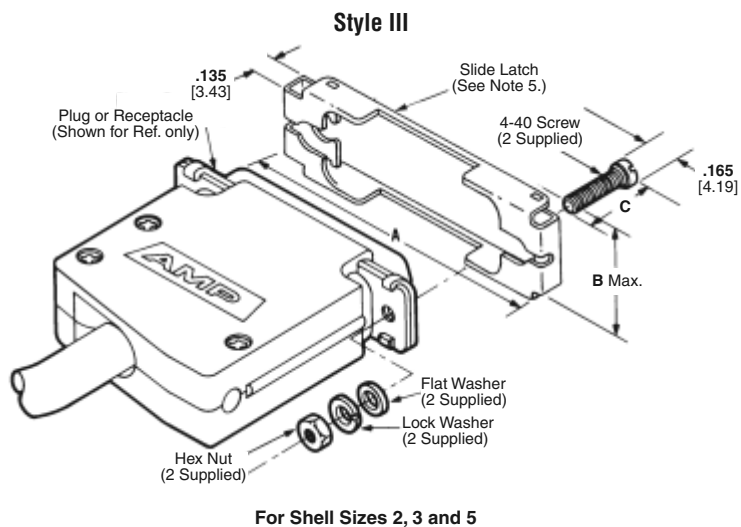
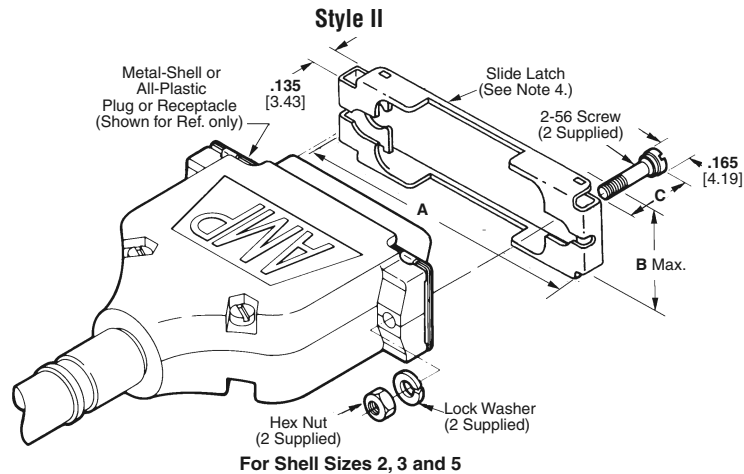

**Hardware** (Continued)

**Slide Latches**



Typical Applications of Locking Posts and Slide Latches

Shell Size	Style	Dimensions			Slide Latch Kit Numbers		Side Latch Only
		A	B	C	Individual	Bulk Packed*	
1	I	1.397 35.48	.490 12.45	.415 10.54	5745404-1	—	164890-1
	II	1.725 43.82	.470 11.94	.547 13.89	5745583-1	—	749027-1
2	II	1.725 43.82	.470 11.94	.415 10.54	5745583-5	—	749027-1
		1.725 43.82	.470 11.94	.450 11.43	5745583-7	—	—
	III	1.725 43.82	.470 11.94	.415 10.54	—	5748653-1	—
		1.725 43.82	.490 12.45	.290 7.37	5749028-1 <sup>7</sup>	—	—
	III	1.725 43.82	.437 11.10	.415 10.54	—	5786138-1 <sup>7</sup>	—
		II	2.265 57.53	.470 11.94	.547 13.89	5745584-1	—
3	III	2.265 57.53	.470 11.94	.415 10.54	5745584-3	—	749996-1
	I	2.913 73.99	.490 12.45	.415 10.54	5745407-1	—	164890-4
4	I	2.913 73.99	.490 12.45	.415 10.54	5745407-1	—	164890-4
5	III	2.819 71.60	.575 14.61	.415 10.54	5745578-3	—	749997-1
		2.819 71.60	.575 14.61	.415 10.54	5745578-3	—	749997-1

\*Each part is individually bulk packed for multiple kit orders.

- Notes:**
1. All parts are packaged unassembled.
  2. Each kit is comprised of a slide latch and two screws, flat washers (if required), lock washers and hex nuts. Style I slide latches are also furnished as part of cable clamp kits (page 142).
  3. Style I slide latches can be used with cable clamps that do not extend beyond the front flange of the connector or on connectors without cable clamps.
  4. Style II slide latches can be used with any cable clamp that has the mounting ear configuration as shown above.
  5. Style III slide latches can be used on connectors without cable clamps or with cable clamps that do not have the mounting ear configuration shown with Style II above.
  6. Slide latches mate with locking posts (page 151).
  7. No nuts, washers, or lockwashers.

**Note:** All part numbers are RoHS compliant.

**Hardware** (Continued)

**Slide Latch Clip Assembly for Unfiltered Mating Half**

**Material and Finish:**

**Screw, Washers and Hex Nut**—Cold rolled steel, zinc plated clear chromate  
**Clip**—Stainless steel

**Technical Documents:**

**Instruction Sheet**—408-7785



**Notes:**

1. All parts are packaged unassembled.
2. Slide Latch Clip Assemblies can be used on any Subminiature D AMPLIMITE HD-20 metal-shell plug or receptacle.
3. Slide Latch Clip Assemblies mate with Locking Post Assemblies shown below.

**Kit Part Numbers:**

Thread Size	Screw Length L	Pkg.	Screw Style	Part No.
4-40	.415	Unit†	1	5206942-1
	10.54	Bulk		5206942-2
2-56	.547	Unit	2	5748078-1**
	13.89	—		—

† Two assemblies per package.

\* Each part is individually bulk packed for multiple kit orders.

\*\* Designed for cable clamps with mounting ears. No flat washers included.

**Locking Post Assembly**

**Material and Finish:**

**All Parts**—Cold rolled steel, zinc plated clear or yellow chromate

**Related Product Data:**

**Connectors used with:**  
**HDE Metal-Shell or All-Plastic**—pages 112-115  
**HDF Metal-Shell or All-Plastic**—pages 125 & 126  
**HDP Metal-Shell**—pages 90-102  
**HD Board Mount**—pages 54-71, 78-85, 87-89  
**Instruction Sheets**—  
 408-6551  
 408-7785



**Part No. 206514-1**



**Part No. 747242-1**

**Notes:**

1. All parts are packaged unassembled.
2. Each kit is comprised of two complete assemblies, as illustrated above.
3. For front panel mounting, it is recommended that a shim be used between the connector flange and panel to prevent bowing of the flange.
4. Locking posts with 2-56 thread size are to be used with cable clamps with mounting flanges. Locking posts with 4-40 thread size can be used with all other cable clamps
5. Locking posts mate with slide latches (page 149).

Thread Size	Locking Post Finish	Dimensions		Locking Post Kit Number (See Note 4)	
		A	B	Individual	Bulk Packed*
4-40	Yellow Chromate	.410	.110	5206514-1	5206514-3
	Clear Chromate	.410	.110	5206514-4	—
	Yellow Chromate	10.41	2.79	5206514-6	5206514-7
2-56	Yellow Chromate	.560	.110	5747242-1	—
	Yellow Chromate	14.22	2.79	—	—

\*Each part is individually bulk packed for multiple kit orders.

**Note:** All part numbers are RoHS compliant.

**Hardware** (Continued)

**Material**

.015 [0.38] Stainless steel

**Related Product Data:**

**Connectors used with:**  
**HDE Metal-Shell**—pages 114 & 115  
**HDP Metal-Shell (Tin plated only)**—pages 90-102

**Technical Documents:**

**Instruction Sheet**—408-9130

**Spring Latches for Cable Clamps with Mounting Ears (Two-Piece)**



**Spring Latch Part Numbers:**  
**745255-2** (two per package)  
**745255-3** (bulk packed)\*

\*Two-piece spring latches are individually bulk packed for multiple part orders.

- Notes:**
- Two-piece spring latches can be used with RFI/EMI shields (pages 141).
  - Two-piece spring latches mate with latching blocks (pages 153 & 154).

**Typical Application of Two-Piece Spring Latches with Straight Exit RFI/EMI Shield**

**Spring Latches (Two-Piece)**

**Material:**

Stainless steel

**Related Product Data:**

**Connectors used with:**  
**HDE Metal-Shell**—pages 114 & 115  
**HDP Metal-Shell**—pages 90-102

**Technical Documents:**

**Instruction Sheet**—408-9131

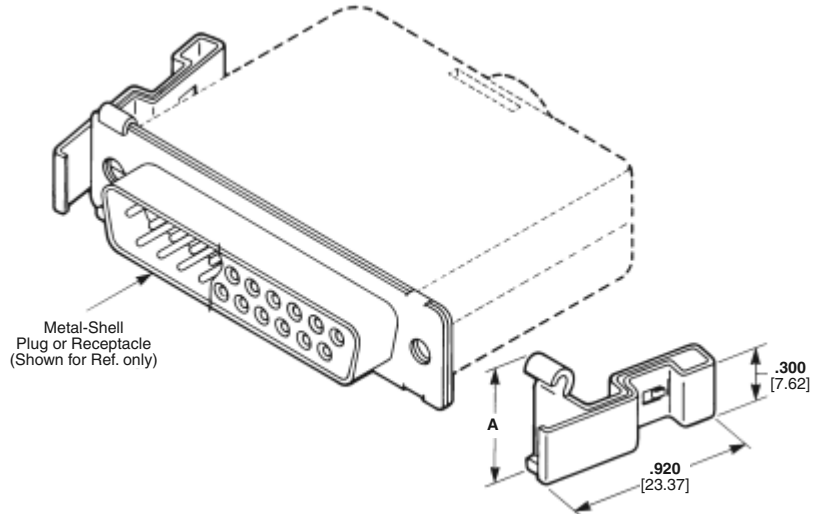

**Spring Latch Part Numbers**

Size	Dimension A	Two Per Package	Bulk Packed*
1-4	.540 13.72	745779-2	745779-3
5	.650 16.51	745779-5	—

\*Two-piece spring latches are individually bulk packed for multiple part orders.

- Notes:**
- These dimensions must be maintained to assure satisfactory operation of the spring latches.
  - Two-piece spring latches mate with latching blocks (pages 153 & 154).

**Note:** All part numbers are RoHS compliant.

**Typical Application of Two-Piece Spring Latches with Post Molded Strain Relief**



**Hardware** (Continued)

**Material and Finish:**  
**Latching Blocks**—Zinc  
**Pan Head Screws**—Steel, zinc plated

**Related Product Data:**  
**Connectors used with:**  
**HDE Metal-Shell or All-Plastic**—  
 pages 112-115  
**HDF Metal-Shell or All-Plastic**—  
 pages 125 & 126  
**HDP Metal-Shell**—pages 90-102  
**HD Board Mount**—pages 54-71,  
 78-85, 87-89  
**Mating/Panel Mounting**—page 136

**Technical Documents:**  
**Instruction Sheet**—408-9128

**Latching Blocks with Threaded Hole**

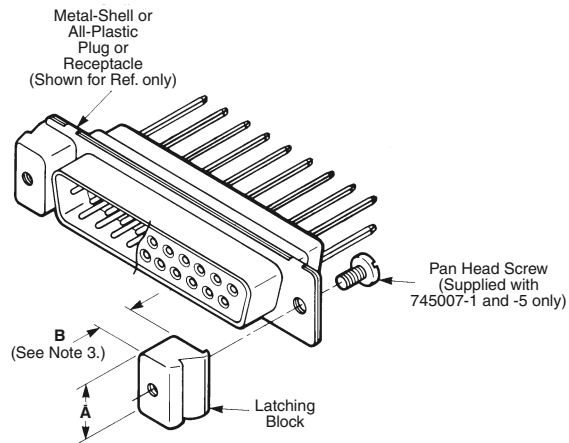

Shell (No. of Contact Pos.)	Dimensions		Panel Thickness	Thread Size	Rear-Panel Latching Block Part No.		Front-Panel Latching Block Part No.	
	A	B			Individual	Bulk Packed*	Individual	Bulk Packed*
1 thru 4 (9 thru 37)	.400 10.16	.190 4.83	.060 1.52	M3 (Metric)	—	745403-2	—	—
				4-40	745403-8	—	—	
	.400 10.16	.220 5.59	.030 0.76	4-40	747717-2	—	—	
				—	—	—	—	
5 (50)	.400 10.16	.250 6.35	—	M3 (Metric)	—	—	5745007-1	—
				4-40	—	—	208101-1	208101-2
	.530 13.46	.250 6.35	—	4-40	—	—	208101-8	208101-9
				—	—	—	1-208101-1	—

\*Bulk packed for multiple part orders.  
 \*\*Individual kits contain two latching blocks per package.

- Notes:**
1. All parts are packaged unassembled.
  2. Each front panel latching block kit is comprised of two latching blocks. Two pan head screws of the appropriate length and thread size to be supplied by customer.
  3. B dimension .250 [6.35] is for connector flange mounting, .220 [5.59] is for use with .030 [0.76] thick panels, and .190 [4.83] is for use with .060 [1.52] thick panels.
  4. Latching blocks mate with spring latches (page 152).

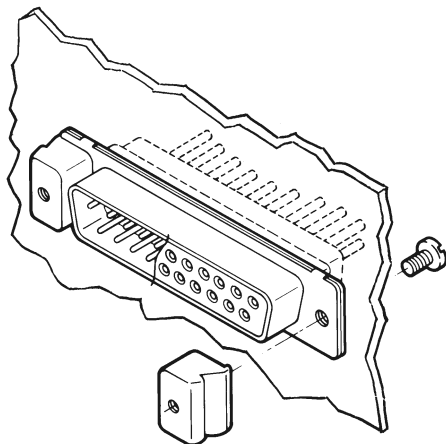

**Typical Application of Front-Panel Mounted Subminiature D Connector using Front-Panel Latching Blocks**

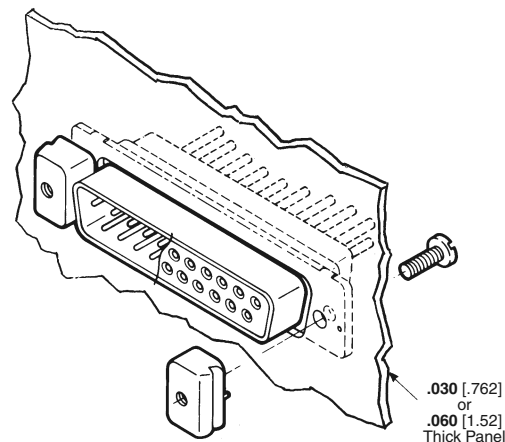

**Typical Application of Rear-Panel Mounted Subminiature D Connector using Rear-Panel Latching Blocks**

**Note:** All part numbers are RoHS compliant.



**Hardware** (Continued)

**Material**

Latching Blocks—Zinc

**Related Product Data:**

- Connectors used with:**
- HDE Metal-Shell or All-Plastic**—pages 112-115
- HDF Metal-Shell or All-Plastic**—pages 125 & 126
- HDP Metal-Shell**—pages 90-102
- HD Board Mount**—pages 54-71, 78-85, 87-89
- Mating/Panel Mounting**—page 136

**Technical Documents:**

Instruction Sheet—408-9128

**Latching Blocks with Slot Recess and Thru Hole**



Shell (No. of Contact Pos.)	Dimensions		Panel Thickness	Rear-Panel Latching Block Part No.		Front-Panel Latching Block Part No.
	A	B		Individual	Bulk Packed*	Individual
1 thru 4 (9 thru 37)	.400 10.16	.160 4.06	.090 2.29	747080-2	—	—
		.190 4.83	.060 1.52	745245-2	745245-3	—
		.250 6.35	—	—	—	745286-2
5 (50)	.530 13.46	.190 4.83	.060 1.52	—	—	745245-5

\*Bulk packed for multiple part orders.

\*\*Individual kits contain two latching blocks per package.

- Notes:**
1. Mounting screws and nuts are to be supplied by Customer.
  2. These latching blocks allow mounting screws to be installed thru the front of the block and to be screwed into the bracket of a right-angle connector, a fixed insert in a connector mounting flange, or a nut behind the connector mounting flange (as illustrated above).
  3. Latching blocks mate with spring latches (page 152).



**Typical Application of Front-Panel Mounted Subminiature D Connector using Front-Panel Latching Blocks**



**Typical Application of Rear-Panel Mounted Subminiature D Connector using Rear-Panel Latching Blocks**

**Note:** All part numbers are RoHS compliant.

**Hardware** (Continued)

**Standoff Bushings**

**Material:**

Aluminum

**Related Product Data:**

**Connectors used with:**  
**HD Straight Posted**—  
 pages 76-85, 87-89

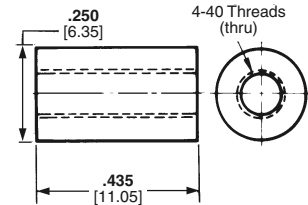

**Kit Numbers:**

**205933-3** (two bushings per package)

**205933-4** (bulk packed)\*

\*Parts are individually bulk packed for multiple part orders.

**Keying Plug**  
 (for Size 20 Socket Contacts)

**Material:**

Polyphenylene oxide

**Related Product Data:**

**Connectors used with:**  
**All HDE, HDP and HD Receptacles**  
 with Socket Contacts

**Keying Plug**

**499712-1 AMP-LATCH** (electrical connectors) can be used on **HD22 Socket Contacts**

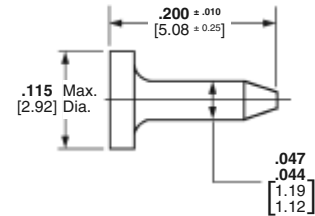
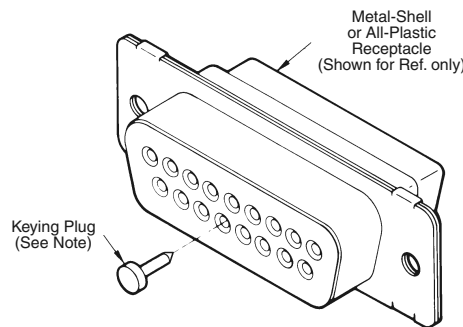

**Part Number: 206509-1**

- Notes:**
1. Keying plug is installed taper-end first into front of receptacle.
  2. Sold individually.

**EMI/RFI Gaskets**

**Material and Finish:**

Brass, .006 [0.15] thick; bright tin plated

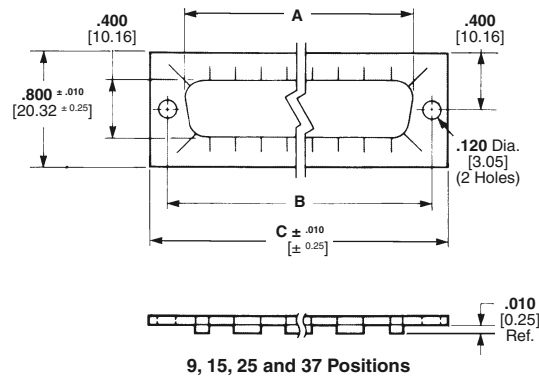

Shell Size (No. of Contact Pos.)	Dimensions			Gasket Part No.
	A	B	C	
1 (9)	.746 18.95	.984 24.99	1.220 30.99	5747024-3
2 (15)	1.074 27.28	1.312 33.32	1.555 39.50	5747025-3
3 (25)	1.614 41.00	1.852 47.04	2.100 53.34	745776-4
4 (37)	2.266 57.56	2.500 63.50	2.730 69.34	745777-4

**Note:** All part numbers are RoHS compliant.



Компания «ЭлектроПласт» предлагает заключение долгосрочных отношений при поставках импортных электронных компонентов на взаимовыгодных условиях!

Наши преимущества:

- Оперативные поставки широкого спектра электронных компонентов отечественного и импортного производства напрямую от производителей и с крупнейших мировых складов;
- Поставка более 17-ти миллионов наименований электронных компонентов;
- Поставка сложных, дефицитных, либо снятых с производства позиций;
- Оперативные сроки поставки под заказ (от 5 рабочих дней);
- Экспресс доставка в любую точку России;
- Техническая поддержка проекта, помощь в подборе аналогов, поставка прототипов;
- Система менеджмента качества сертифицирована по Международному стандарту ISO 9001;
- Лицензия ФСБ на осуществление работ с использованием сведений, составляющих государственную тайну;
- Поставка специализированных компонентов (Xilinx, Altera, Analog Devices, Intersil, Interpoint, Microsemi, Aeroflex, Peregrine, Syfer, Eurofarad, Texas Instrument, Miteq, Cobham, E2V, MA-COM, Hittite, Mini-Circuits, General Dynamics и др.);

Помимо этого, одним из направлений компании «ЭлектроПласт» является направление «Источники питания». Мы предлагаем Вам помощь Конструкторского отдела:

- Подбор оптимального решения, техническое обоснование при выборе компонента;
- Подбор аналогов;
- Консультации по применению компонента;
- Поставка образцов и прототипов;
- Техническая поддержка проекта;
- Защита от снятия компонента с производства.



#### Как с нами связаться

**Телефон:** 8 (812) 309 58 32 (многоканальный)

**Факс:** 8 (812) 320-02-42

**Электронная почта:** [org@eplast1.ru](mailto:org@eplast1.ru)

**Адрес:** 198099, г. Санкт-Петербург, ул. Калинина, дом 2, корпус 4, литера А.