

MINI-PS- 12- 24DC/ 5-15DC/2

Power supply unit

INTERFACE

Data sheet
104346_en_01



© PHOENIX CONTACT 2011-09-21

1 Description

The DC/DC converter converts the DC voltage of 12 V DC ... 24 V DC to an adjustable, controlled and electrically isolated 5 V DC ... 15 V DC output voltage.

Due to electrical isolation, the DC voltage circuits are electrically isolated from each other in a safe way. The active "DC-OK" switching output as well as an LED are available for signaling. With a design width of only 22.5 mm, the housing is extremely slim.

Features

- Reliable power supply unit even at high ambient temperatures
- Reliable starting of heavy loads using the U/I characteristic curve
- Can be used worldwide in all industrial sectors due to a wide-range input and an international approval package
- High operating safety due to long mains buffering under full load and high MTBF (> 500,000 h)



DANGER OF EXPLOSION!

Only remove equipment when it is disconnected and not in the potentially explosive area.



DANGER

Components with dangerously high voltage and high stored energy are located in the device!
Never carry out work on live parts!
Depending on the ambient temperature and the load, the housing can become very hot!



Make sure you always use the latest documentation.
It can be downloaded from the product at www.phoenixcontact.net/catalog.

2 Table of contents

1	Description	1
	Features.....	1
2	Table of contents.....	2
3	Ordering data	3
4	Technical data	3
5	Structure.....	5
6	Block diagram	6
7	Safety notes	6
8	Installation	7
9	Mounting position	7
	Assembly	8
	Removing.....	8
10	Input	8
	Protection of the primary side.....	8
11	Output	9
	Protection of the secondary side	9
12	Signaling	9
	Active signal output.....	10
13	Function	10
	Thermal behavior	10
	Parallel operation	10
	Redundant operation	11
	Increased performance	11

3 Ordering data

Description	Type	Order No.	Pcs. / Pkt.
DC/DC converter, primary-switched, slim design, input: 12 - 24 V DC, output: 5 - 15 V DC/2 A	MINI-PS- 12- 24DC/ 5-15DC/2	2320018	1

4 Technical data

Input data	
Nominal input voltage range	12 V DC ... 24 V DC
DC input voltage range	10 V DC ... 32 V DC (> 10.5 V DC start)
DC frequency range	0 Hz
Current consumption	Approx. 2.3 A (12 V DC) Approx. 1.1 A (24 V DC)
Inrush current limitation	< 10 A (typical)
I^2t	0.2 A ² s
Power failure bypass	> 4 ms (12 V DC) > 18 ms (24 V DC)
Typical response time	< 0.5 s
Input fuse, integrated	6.3 A (slow-blow, internal)
Output data	
Nominal output voltage	12 V DC \pm 1%
Setting range of the output voltage	5 V DC ... 15 V DC
Output current	2 A (-25 °C ... 60 °C)
Efficiency	> 88 % (at 24 V DC and nominal values)
Residual ripple	< 20 mV _{PP} (20 MHz)
Peak switching voltages	< 10 mV _{PP} (20 MHz)
Connection in parallel	Yes, for assembling redundant systems and increasing efficiency
Connection in series	Yes
Protection against internal surge voltages	Yes, < 25 V DC
Resistance to reverse feed	30 V DC
Power consumption	
Maximum power dissipation idling	< 1 W
Power loss nominal load max.	< 4.2 W
DC OK active	
Output description	$U_{OUT} > 0.9 \times U_N$: High signal
Status display	"DC OK" LED green / $U_{OUT} > 0.9 \times U_N$: LED ON
General data	
Insulation voltage input/output	1 kV (routine test) 1.5 kV (type test)
Degree of protection	IP20
Protection class	III
MTBF (IEC 61709)	500000 h
Type of housing	Polyamide PA, color: green
Housing material	Polyamide (PA)
Dimensions W / H / D (state of delivery)	22.5 mm / 99 mm / 107 mm
Weight	0.2 kg

Ambient conditions

Ambient temperature (operation)	-25 °C ... 70 °C (> +60°C derating)
Ambient temperature (storage/transport)	-40 °C ... 85 °C
Max. permissible relative humidity (operation)	≤ 95 % (At +25°C, no condensation)
Vibration (operation)	< 15 Hz, amplitude ±2.5 mm in acc. with IEC 60068-2-6 15 Hz ... 150 Hz, 2.3 g
Shock	30g in all directions in acc. with IEC 60068-2-27
Pollution degree in acc. with EN 50178	2
Climatic class	3K3 (in acc. with EN 60721)

Approvals

UL approvals	UL/C-UL listed UL 508 UL/C-UL Recognized UL 60950
--------------	--



Current approvals can be found for the product in the download area.

Conformance with EMC Directive 2004/108/EC

Noise immunity according to EN 61000-6-2

Electrostatic discharge	EN 61000-4-2
	Housing > Level 3
	Contact discharge 8 kV (Contact discharge)
	Discharge in air 8 kV (Air discharge)
	Comments Criterion B
Electromagnetic HF field	EN 61000-4-3
	Housing Level 3
	Frequency range 80 MHz ... 3 GHz
	Comments Criterion A
Fast transients (burst)	EN 61000-4-4
	Input 4 kV (level 4 - asymmetrical: conductor to ground)
	Output 2 kV (level 3 - asymmetrical: conductor to ground)
	Signal 1 kV (Level 2 - asymmetrical cable to ground)
	Comments Criterion B
Surge current loads (surge)	EN 61000-4-5
	Input 2 kV (Level 3) 1 kV (Level 3)
Conducted interference	EN 61000-4-6
	Input/output Level 3
	Frequency range 0.15 MHz ... 80 MHz (10 V)
Voltage dips	EN 61000-4-11
	Input (> 10 ms)
	Comments Criterion B

Emitted interference in acc. with EN 61000-6-3

Radio interference voltage in acc. with EN 55011	EN 55011 (EN 55022) Class B, area of application: Industry and residential
Emitted radio interference in acc. with EN 55011	EN 55011 (EN 55022) Class B, area of application: Industry and residential

5 Structure

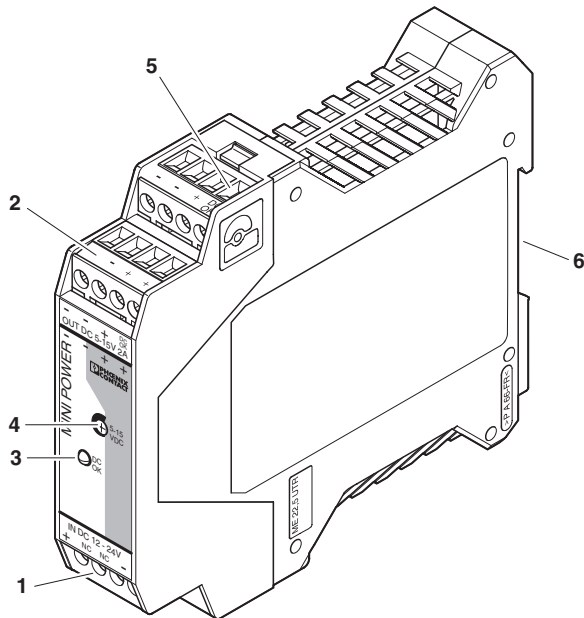

- 1 DC input
- 2 DC output
- 3 LED green: DC OK
- 4 Potentiometer: 5 V DC ... 15 V DC
- 5 Active switching output: DC OK
- 6 Universal snap-on foot for EN DIN rails

	[mm ²]		AWG	[Nm] Torque
	solid	stranded		
Input	0.2 - 2.5	0.2 - 2.5	24 - 14	0.5 - 0.6
Output	0.2 - 2.5	0.2 - 2.5	24 - 14	0.5 - 0.6
Signal	0.2 - 2.5	0.2 - 2.5	24 - 14	0.5 - 0.6

Input data

Nominal input voltage range	12 V DC ... 24 V DC
DC input voltage range	10 V DC ... 32 V DC (> 10.5 V DC start)
DC frequency range	0 Hz
Input fuse, integrated	6.3 A (slow-blow, internal)
Connection method	Pluggable screw connection
Stripping length	7 mm

Output data

Nominal output voltage	12 V DC \pm 1%
Setting range of the output voltage	5 V DC ... 15 V DC
Output current	2 A (-25 °C ... 60 °C)
Connection method	Pluggable screw connection
Stripping length	7 mm

6 Block diagram

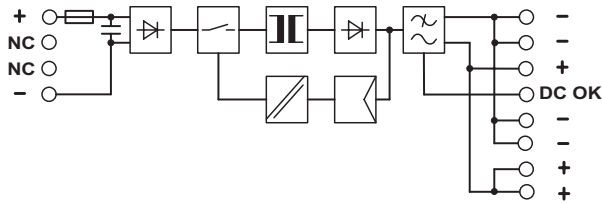

7 Safety notes



DANGER OF EXPLOSION!

Only remove equipment when it is disconnected and not in the potentially explosive area.

DANGER

Components with dangerously high voltage and high stored energy are located in the device!

Never carry out work on live parts!

Depending on the ambient temperature and the load, the housing can become very hot!



CAUTION:

Before startup please ensure:

The mains connection has been carried out by a competent person and protection against electric shock is guaranteed!

The device can be disconnected outside the power supply unit in accordance with the regulations as in EN 60950 (e.g. through primary side line protection)!

All feed lines are sufficiently protected and dimensioned!

All output lines are dimensioned according to the maximum output current of the device or separately protected!

Sufficient convection must be guaranteed.



ATTENTION: Danger if used improperly

The power supply units are built-in devices. The device may only be installed and put into operation by qualified personnel. The corresponding national regulations must be observed.

8 Installation

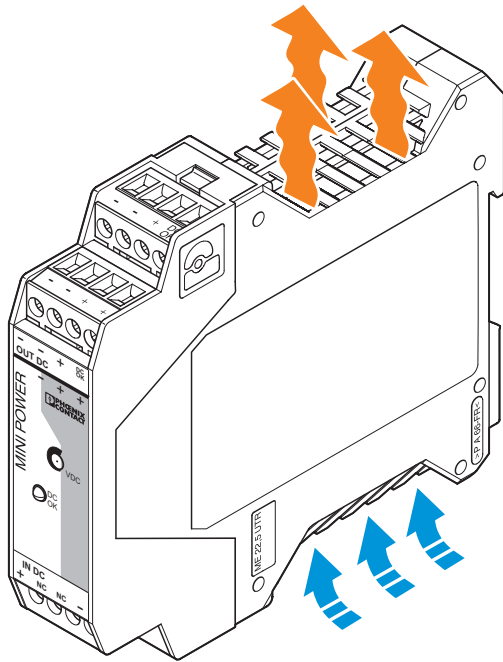

ATTENTION: Module can become damaged

To ensure sufficient convection, we recommend the following minimum spacing be used between modules: 5 cm above and below



The power supply unit can be snapped onto all DIN rails in acc. with EN 60715.

9 Mounting position

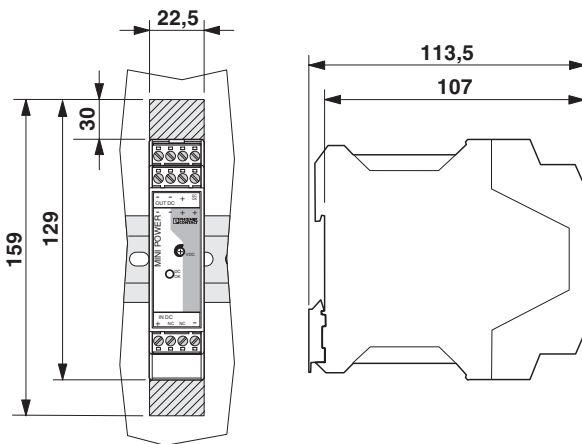

Mounting position: Installation depth 107 mm (+ DIN rail)

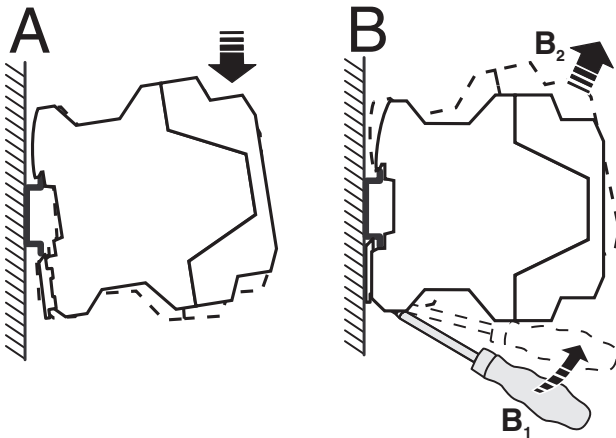

Assembly

Position the module with the DIN rail guide on the upper edge of the DIN rail, and snap it in with a downward motion.

Removing

Pull the snap lever open with the aid of a screwdriver and slide the module out at the lower edge of the DIN rail.

10 Input

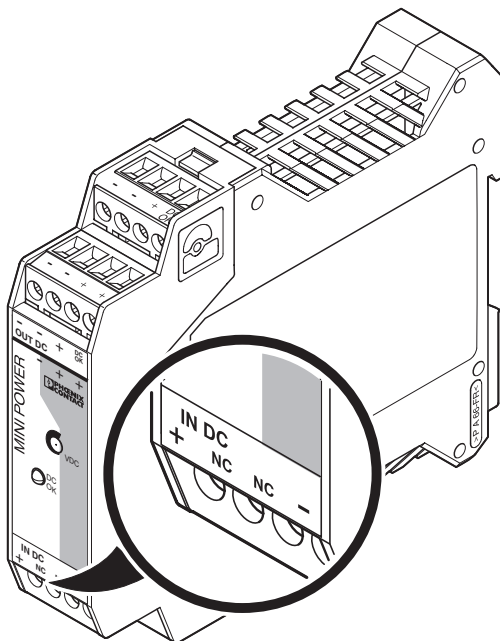

ATTENTION: Module can become damaged

If an internal fuse is triggered, there is a device malfunction. In this case, the device must be inspected in the factory.

The 12 V DC ... 24 V DC connection is established using the "+" and "-" screw connections.

Protection of the primary side

The device must be installed in acc. with the regulations as in EN 60950. An internal fuse is provided for device protection. Additional device protection is not required.

11 Output

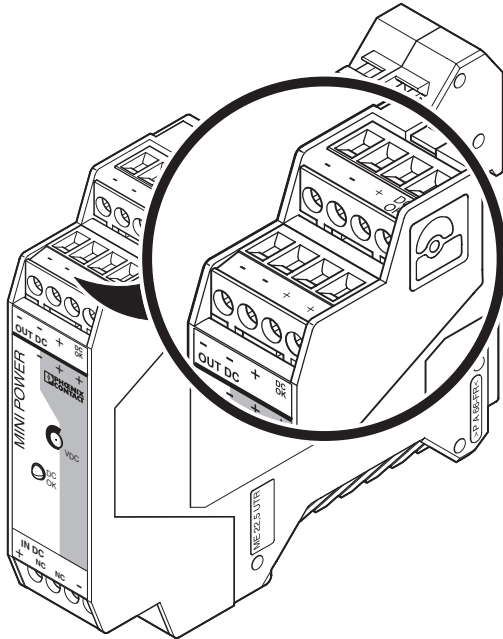

ATTENTION: Module can become damaged

Make sure that all output lines are dimensioned according to the maximum output current or are separately protected. The cables on the secondary side must have sufficiently large cross sections in order to keep the voltage drops on the lines as low as possible.

The connection is made via screw connection terminal blocks "+" and "-" of the DC output. The output voltage can be set on the potentiometer from 5 V DC ... 15 V DC.

Protection of the secondary side

The device is electronically protected against short-circuit and idling. In the event of a malfunction, the output voltage is limited to 25 V DC. Make sure that all output lines are dimensioned according to the maximum output current or are separately protected. The cable cross sections in the secondary circuit should be large enough to keep the voltage drops on the cables as low as possible.

12 Signaling

For function monitoring, there is the active DC OK switching output and the DC OK LED.

	State 1	State 2
"DC OK" LED	ON	OFF
Active DC OK switching output	U_{OUT} (with reference to "-")	$U = 0\text{ V}$ (in reference to "-")
Meaning	Normal operation of the power supply unit. $U_{OUT} > 0.9 \times U_N$	$U_{OUT} \leq 0.9 \times U_N$ Secondary load short-circuit or overload No mains voltage or device defective

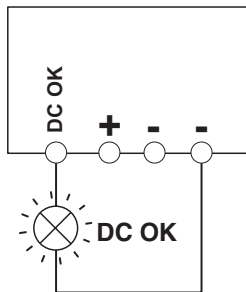

Active signal output

The DC output signal in normal operation of the power supply unit ($U_{OUT} > 0.9 \times U_N$) is between the "DC OK" and "-" connection terminal blocks and can carry a maximum of 20mA. By switching from "active high" to "low", the DC OK signal output signalizes when the output voltage is fallen short of by more than 10%.

The DC OK signal is decoupled from the power output. It is thus not possible for devices connected in parallel to act as an external power supply.

13 Function

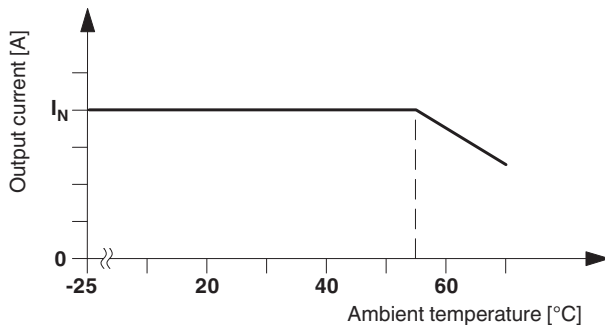

Thermal behavior

The device can supply a nominal output current of 2 A with ambient temperatures of up to 60°C. For ambient temperatures above 60°C, the output current must be reduced by 2.5% per Kelvin increase in temperature. From 70°C onwards or in the case of thermal overload, the device reduces the output capacity for its own protection, and returns to normal operation when it has cooled down.

Parallel operation

Devices of the same type can be connected in parallel to increase both redundancy and power. By default upon delivery, no further adjustments are required.

If the output voltage is adjusted, a uniform distribution of power is guaranteed by setting all parallel operated power supply units to exactly the same output voltage.

To ensure symmetrical current distribution we recommend that all cable connections from the power supply unit to the busbar are the same length and have the same cross section. Depending on the system, for parallel connection of more than two power supplies a protective circuit should be installed at each individual device output (e.g., decoupling diode, DC fuse or circuit breaker). This prevents high return currents in the event of a secondary device fault.

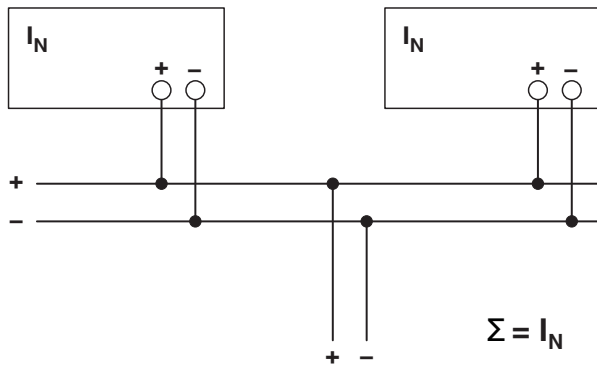

Redundant operation

Redundant circuits are suitable for supplying systems, which place particularly high demands on operational safety. If a fault occurs in the primary circuit of the first power supply unit, the second device automatically takes over the complete power supply without interruption, and vice versa. For this purpose, the power supply units to be connected in parallel must be large enough that the total current requirements of all loads can be fully met by one power supply unit. External decoupling diodes are required for 100% redundancy (TRIO-DIODE/12-24DC/2X10/1X20, Order No. 2866514).

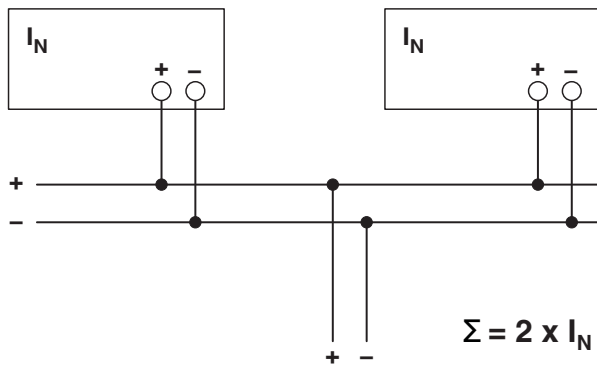

Increased performance

For n parallel connected devices, the output current can be increased to $n \times I_N$. Parallel connection for increasing power is used when extending existing systems. A parallel connection is recommended if the power supply unit does not cover the current consumption of the most powerful load. Otherwise, the load should be divided between individual devices that are independent from one another.



Компания «ЭлектроПласт» предлагает заключение долгосрочных отношений при поставках импортных электронных компонентов на взаимовыгодных условиях!

Наши преимущества:

- Оперативные поставки широкого спектра электронных компонентов отечественного и импортного производства напрямую от производителей и с крупнейших мировых складов;
- Поставка более 17-ти миллионов наименований электронных компонентов;
- Поставка сложных, дефицитных, либо снятых с производства позиций;
- Оперативные сроки поставки под заказ (от 5 рабочих дней);
- Экспресс доставка в любую точку России;
- Техническая поддержка проекта, помощь в подборе аналогов, поставка прототипов;
- Система менеджмента качества сертифицирована по Международному стандарту ISO 9001;
- Лицензия ФСБ на осуществление работ с использованием сведений, составляющих государственную тайну;
- Поставка специализированных компонентов (Xilinx, Altera, Analog Devices, Intersil, Interpoint, Microsemi, Aeroflex, Peregrine, Syfer, Eurofarad, Texas Instrument, Miteq, Cobham, E2V, MA-COM, Hittite, Mini-Circuits, General Dynamics и др.);

Помимо этого, одним из направлений компании «ЭлектроПласт» является направление «Источники питания». Мы предлагаем Вам помощь Конструкторского отдела:

- Подбор оптимального решения, техническое обоснование при выборе компонента;
- Подбор аналогов;
- Консультации по применению компонента;
- Поставка образцов и прототипов;
- Техническая поддержка проекта;
- Защита от снятия компонента с производства.



Как с нами связаться

Телефон: 8 (812) 309 58 32 (многоканальный)

Факс: 8 (812) 320-02-42

Электронная почта: org@eplast1.ru

Адрес: 198099, г. Санкт-Петербург, ул. Калинина, дом 2, корпус 4, литера А.