

A

B

C

D

A

B

C

D

PRODUCT NUMBER  
51760-ABBCCDEF...  
NOTE: (3)  
SEE NOTE 1

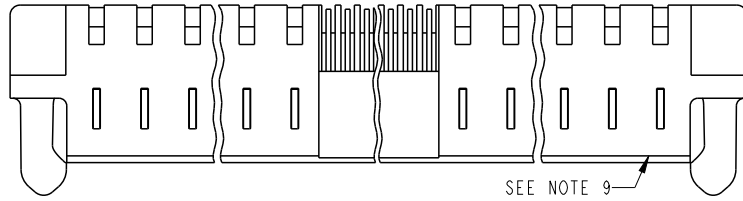

SEE NOTE 9

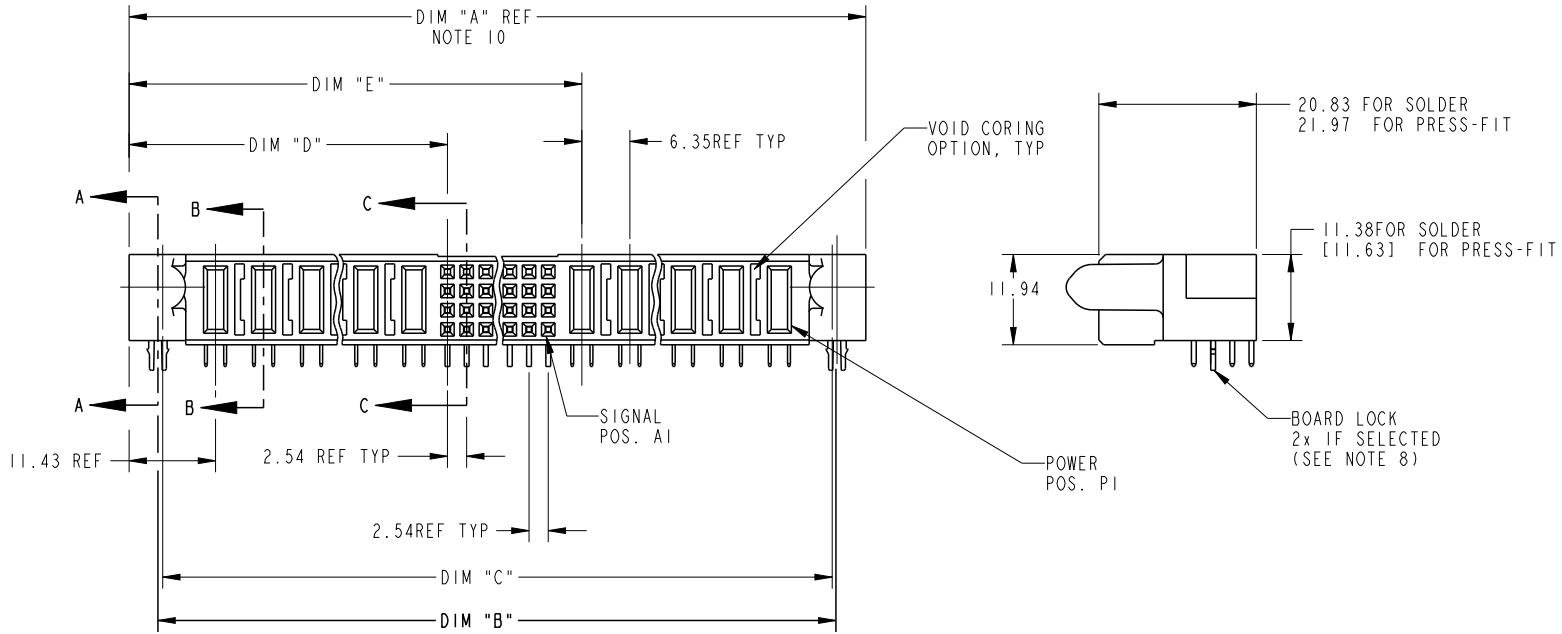

spec ref *		dr Julia Wang		2008/09/29		projection		size A4		scale 1:1			
tolerance std		eng Vicking Liu		2017/03/07				MM		ecn no ELX-DG-26294-1			
ISO 406 ISO 1101		chr Fancy Zhang		2017/03/07									
TOLERANCES UNLESS OTHERWISE SPECIFIED		appr Pei-Ming Zheng		2017/03/08		product family PwrBlade		rel level Released					
surface		linear		<b>Amphenol FCI</b> RA REC w/GUIDE PIN POWER / SIGNAL / POWER		dwg no 51760		rev N					
ISO 1302		0.X								±0.3			
		0.XX								±0.13			
		0.XXX		±0.051									
		angular		0°		±2°							
		cat. no.				-		Product - Customer Drw		sheet 1 of 3			

PRODUCT NUMBER	DIM	LENGTH FORMULAS (SEE NOTE 10)
51760-ABBCCDDEF... NOTE: ③	DIM "A"	.250 [6.35] x DD + .100 [2.54] x (CCC/4) + .250 [6.35] x BB + .650 [16.51] (NOTE 10)
SEE NOTE 1	DIM "B"	.250 [6.35] x DD + .100 [2.54] x (CCC/4) + .250 [6.35] x BB + .350 [8.89]
	DIM "C"	.250 [6.35] x DD + .100 [2.54] x (CCC/4) + .250 [6.35] x BB + .300 [7.62]
	DIM "D"	.250 [6.35] x DD + .375 [9.53] $\Delta$
	DIM "E"	.250 [6.35] x DD + .100 [2.54] x (CCC/4) + .450 [11.43]
	DIM "F"	.250 [6.35] x DD + .100 [2.54] x (CCC/4) + .250 [6.35] x BB + .680 [17.27]
	DIM "G"	.250 [6.35] x DD + .225 [5.72]
	DIM "H"	.250 [6.35] x DD + .100 [2.54] x (CCC/4) + .250 [6.35]

CONNECTOR NOTES

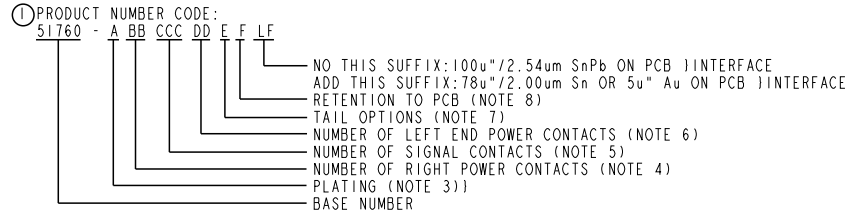

- ② HOUSING MATERIAL: GLASS FILLED V-0 HIGH TEMP THERMO PLASTIC.  
SIGNAL CONTACT MATERIAL: COPPER ALLOY  
POWER CONTACT MATERIAL: COPPER ALLOY
- ③ PLATING OPTION:  
1: SEE IN PRINT 10064183 FOR PLATING SPEC OF 51760-ABBCCDDEF; 51760-ABBCCDDEFLF
- ④ RIGHT END POWER CONTACTS, 01 TO 20 AVAILABLE.  
MAXIMUM OF 20 POWER CONTACTS PER CONNECTOR
- ⑤ SIGNAL CONTACTS, 004 TO 148 AVAILABLE FOR SOLDER TO BOARD.  
020 TO 148 AVAILABLE FOR PRESS-FIT TO BOARD.
- ⑥ LEFT END POWER CONTACTS, 01 TO 20 AVAILABLE.  
MAXIMUM OF 20 POWER CONTACTS PER CONNECTOR
- ⑦ TAIL OPTIONS:  
A = .135 ± .010 [3.43 ± .25] SOLDER TO BOARD  
B = .090 ± .005 / -.010 [2.29 ± .013 / -.25]  
SOLDER TO BOARD  
C = .154 ± .010 [3.91 ± .025] PRESS-FIT TO BOARD
- ⑧ RETENTION TO PCB OPTIONS:  
A = BOARD LOCK (REQUIRES .098 ± .002 / -.001 [2.49 ± 0.05 / -0.03] THRU HOLE IN PCB  
MOUNTING FOOT HEIGHT: .220 [5.59]  
\*\*NOT AVAILABLE FOR PRESS-FIT\*\*

B = .150 [3.81] THRU HOLE (REQUIRES .158 ± 0.003 [4.01 ± 0.08] THRU HOLE IN PCB).  
MOUNTING FOOT HEIGHT  
.160 [4.06]

- ⑨ MANUFACTURE'S NAME, P/N, AND DATE CODE TO APPEAR ON THIS SURFACE.
- ⑩ THE MAXIMUM OVERALL LENGTH (DIM A) OF A PART IS 8.00 [203.2]
- 11. PRODUCT SPECIFICATION GS-12-149
- 12. APPLICATION SPECIFICATION BUS-20-067.
- 13. FOR PRESS-FIT CONNECTORS USE FCI CAM TOOL 430140-XXX TO APPLY CONNECTOR TO PCB.

PCB NOTES:

- 14. ALL DIMENSIONS ARE BASIC UNLESS OTHERWISE SPECIFIED.
- 15. ALL THROUGH HOLES ARE LOCATED WITH A TRUE POSITION OF .004 [0.10]
- 16. ALL HOLE DIAMETERS ARE FINISHED HOLE SIZE.
- ⑬  $\varnothing 0.0453 \pm .001$  [1.151 ± 0.02] DRILLED HOLES PLATED WITH 0.0003 [0.007] MIN SnPb OVER 0.001 [1.03] TO .003 [0.08] PLATING TO ACHIEVE A .040 ± .003 [1.02 ± 0.08] HOLE.
- 18.  $\Delta$  THE VOID CORING IN BETWEEN POWER MODULES, SIGNAL MODULES AND END MODULES ARE OPTIONAL AND THE SHAPE MAY BE DIFFERENT FOR OPTIMIZING THE MOLDING PROCESS. THE VOID CORING WILL NOT EFFECT TO PRODUCT FUNCTION.
- 19.  $\Delta$  A  $\Delta$  SYMBOL WILL BE NEXT TO ANY DIMENSION, VIEW, OR NOTE WHICH HAS BEEN MODIFIED WITH THE CURRENT DRAWING REVISION.

dr	Julia Wang	2008/09/29	projection 	MM 	size	A4	scale	1:2
eng	Vicking Liu	2017/03/07			ecn no	ELX-DG-26294-1		
chr	Fancy Zhang	2017/03/07			product family	PwrBlade		rel level
appr	Pei-Ming Zheng	2017/03/08						

surface ISO 1302	linear	0.X	±0.3	Amphenol FCI	title RA REC w/GUIDE PIN POWER / SIGNAL / POWER	dwg no 51760	rev N	
		0.XX	±0.13					
		0.XXX	±0.051					
	angular	0°	±2°		cat. no.	-	Product - Customer Drw	sheet 2 of 3

PRODUCT NUMBER  
51760-ABBCCDEF...  
NOTE: (3)  
SEE NOTE 1

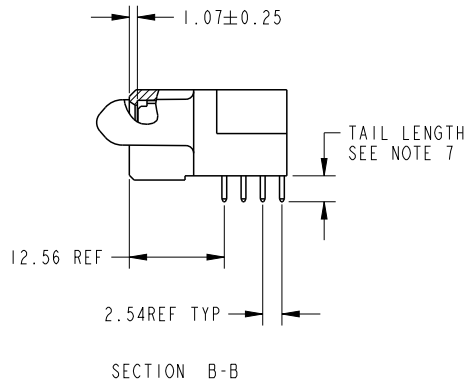
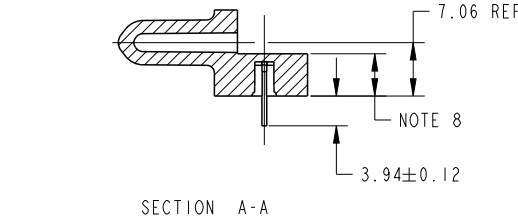

dr	Julia Wang	2008/09/29	projection 	MM ←→	size	A4	scale	1:1
eng	Vicking Liu	2017/03/07			ecn no	ELX-DG-26294-1		
chr	Fancy Zhang	2017/03/07			rel level	Released		
appr	Pei-Ming Zheng	2017/03/08	product family	PwrBlade				

surface	linear	0.X	±0.3
		0.XX	±0.13
		0.XXX	±0.051
	angular	0°	±2°

ISO 1302

Amphenol FCi	title	RA REC w/GUIDE PIN		dwg no	51760		rev	N
		POWER / SIGNAL / POWER						
	cat. no.	-	Product - Customer Drw	sheet 3 of 3				



Компания «ЭлектроПласт» предлагает заключение долгосрочных отношений при поставках импортных электронных компонентов на взаимовыгодных условиях!

Наши преимущества:

- Оперативные поставки широкого спектра электронных компонентов отечественного и импортного производства напрямую от производителей и с крупнейших мировых складов;
- Поставка более 17-ти миллионов наименований электронных компонентов;
- Поставка сложных, дефицитных, либо снятых с производства позиций;
- Оперативные сроки поставки под заказ (от 5 рабочих дней);
- Экспресс доставка в любую точку России;
- Техническая поддержка проекта, помощь в подборе аналогов, поставка прототипов;
- Система менеджмента качества сертифицирована по Международному стандарту ISO 9001;
- Лицензия ФСБ на осуществление работ с использованием сведений, составляющих государственную тайну;
- Поставка специализированных компонентов (Xilinx, Altera, Analog Devices, Intersil, Interpoint, Microsemi, Aeroflex, Peregrine, Syfer, Eurofarad, Texas Instrument, Miteq, Cobham, E2V, MA-COM, Hittite, Mini-Circuits, General Dynamics и др.);

Помимо этого, одним из направлений компании «ЭлектроПласт» является направление «Источники питания». Мы предлагаем Вам помощь Конструкторского отдела:

- Подбор оптимального решения, техническое обоснование при выборе компонента;
- Подбор аналогов;
- Консультации по применению компонента;
- Поставка образцов и прототипов;
- Техническая поддержка проекта;
- Защита от снятия компонента с производства.



#### Как с нами связаться

**Телефон:** 8 (812) 309 58 32 (многоканальный)

**Факс:** 8 (812) 320-02-42

**Электронная почта:** [org@eplast1.ru](mailto:org@eplast1.ru)

**Адрес:** 198099, г. Санкт-Петербург, ул. Калинина, дом 2, корпус 4, литера А.