

Customer Information Sheet

DRAWING No.: G125-MHXXX05L2P

IF IN DOUBT - ASK

©

NOT TO SCALE

THIRD ANGLE PROJECTION

ALL DIMENSIONS IN mm

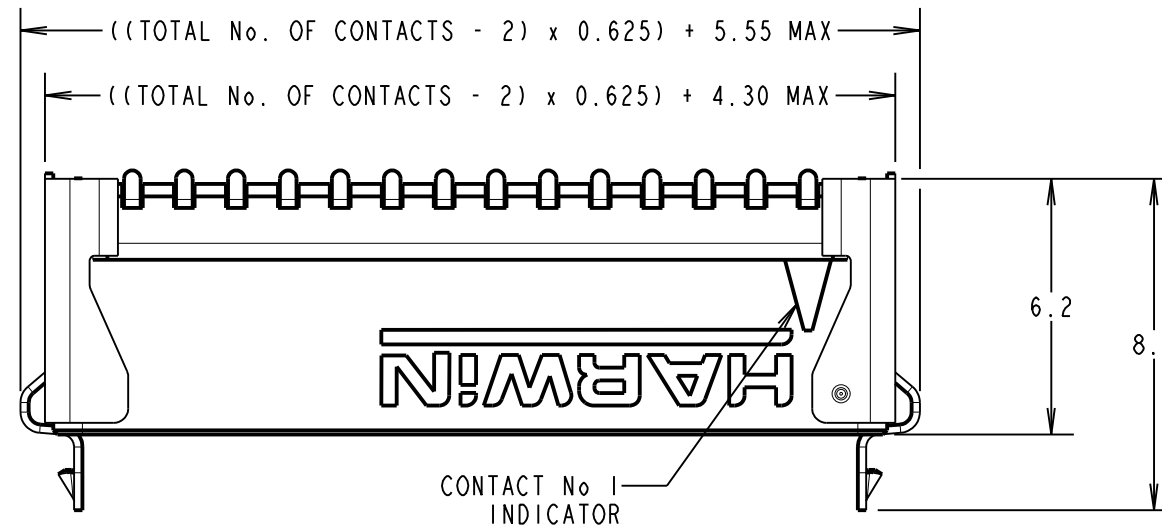
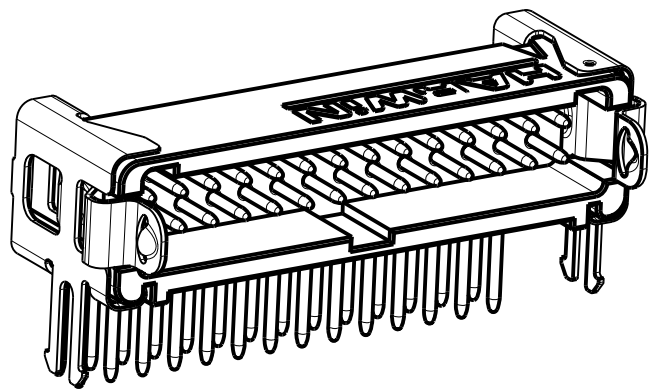

ORDER CODE: **G125-MHXXX05L2P**

CONTACT STYLE: _____
 3.3mm PC-TAIL = H1
 4.8mm PC-TAIL = H2

TOTAL No. OF CONTACTS: _____
 06, 10, 12, 16, 20, 26, 34, 50

LATCHES: _____
 2.5mm BOARD MOUNT & LATCHES = L2

CONTACT STYLE	DIM 'Z'
H1	3.3±0.15
H2	4.8±0.15

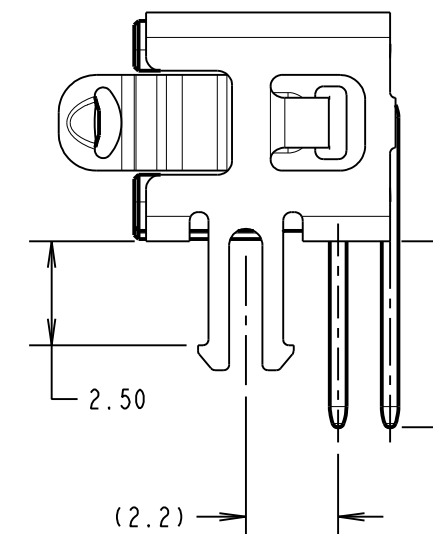
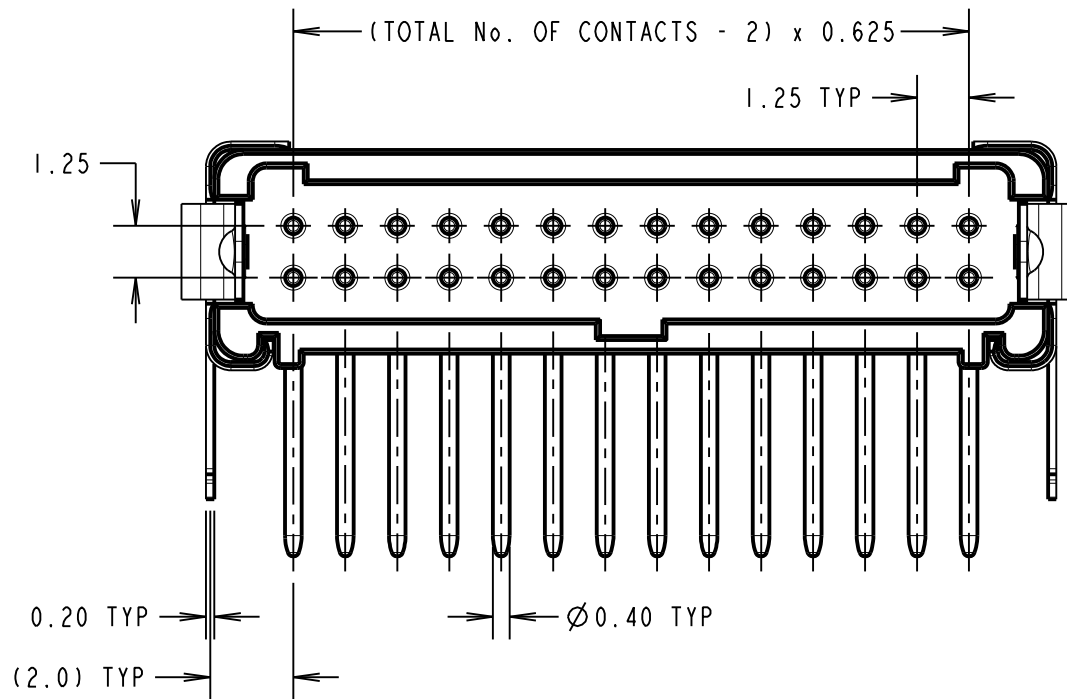
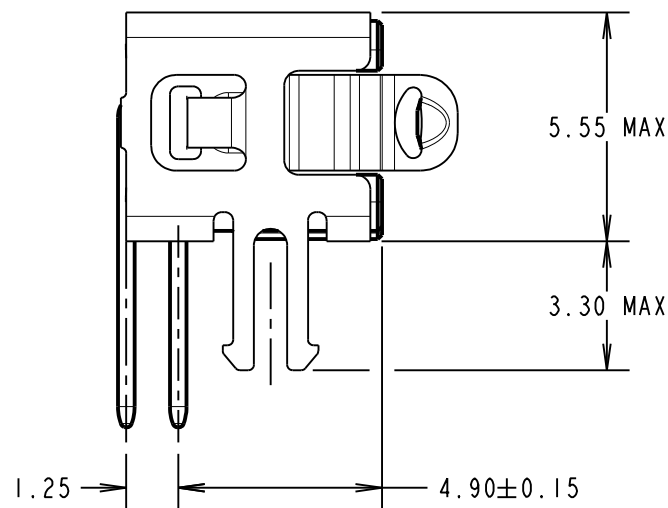

DIM 'Z'
SEE TABLE

FULL LOGO ONLY
ON 20 TO 50 WAY.
'H' ON 6 & 10 WAY.
'HWN' ON 12 & 16 WAY.

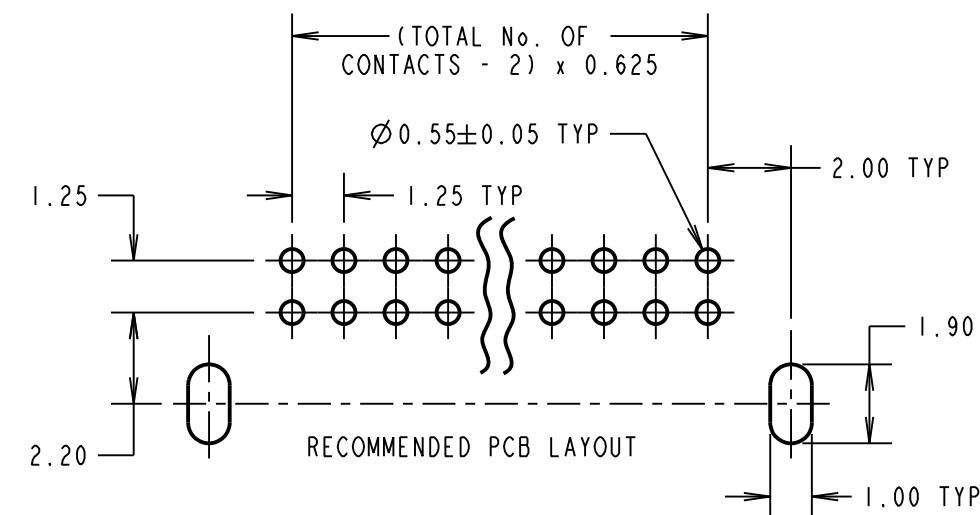
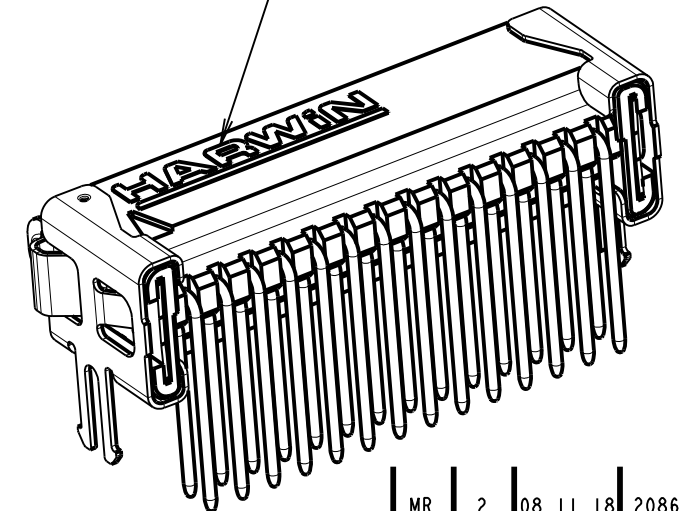

CONNECTOR DETAILS AND PCB LAYOUT ONLY.
SEE SHEET 6 FOR TAPE STRIP DETAILS.

NOTES:
1. FOR COMPLETE SPECIFICATION, SEE COMPONENT SPECIFICATION C125XX (LATEST ISSUE).
SEE G125-SERIES CONNECTORS SPECIFICATION SHEET FOR MATERIALS, FINISH AND SPECIFICATION SUMMARY.

MR	2	08.11.18	20862
NAME	ISS.	DATE	C/NOTE
APPROVED: M.RUDKIN			
CHECKED: M.PLESTED			
DRAWN: MARK G PLESTED			
CUSTOMER REF.:			
ASSEMBLY DRG:			

HARWIN

www.harwin.com
technical@harwin.com

THIS DRAWING AND ANY INFORMATION OR DESCRIPTIVE MATTER SET OUT HEREON ARE CONFIDENTIAL AND COPYRIGHT PROPERTY OF THE HARWIN GROUP AND MUST NOT BE DISCLOSED, LOANED, COPIED OR USED FOR MANUFACTURING, TENDERING OR FOR ANY OTHER PURPOSE WITHOUT THEIR WRITTEN PERMISSION.

TOLERANCES
 X. = ±1mm
 X.X = ±0.50mm
 X.XX = ±0.10mm
 X.XXX = ±0.01mm
 ANGLES = ±5°
 UNLESS STATED

MATERIAL: SEE NOTE 1
 FINISH: SEE NOTE 1
 S/AREA: mm²

TITLE:
G125 MALE HORIZONTAL PC TAIL
SERIES IN TAPE

DRAWING NUMBER:
G125-MHXXX05L2P

SHT
5 OF 6

Customer Information Sheet

DRAWING No.: G125-MHXXX05L2P

IF IN DOUBT - ASK

©

NOT TO SCALE

THIRD ANGLE PROJECTION

ALL DIMENSIONS IN mm

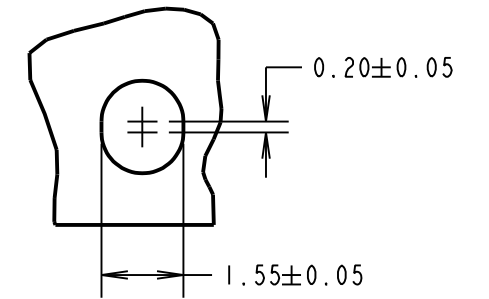
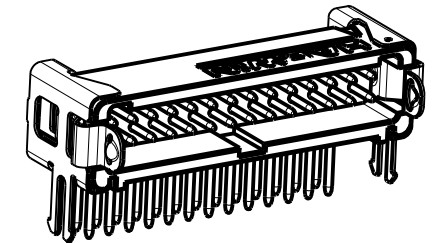
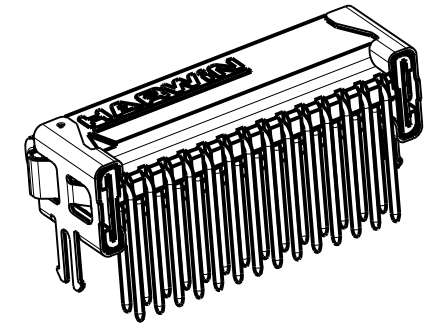
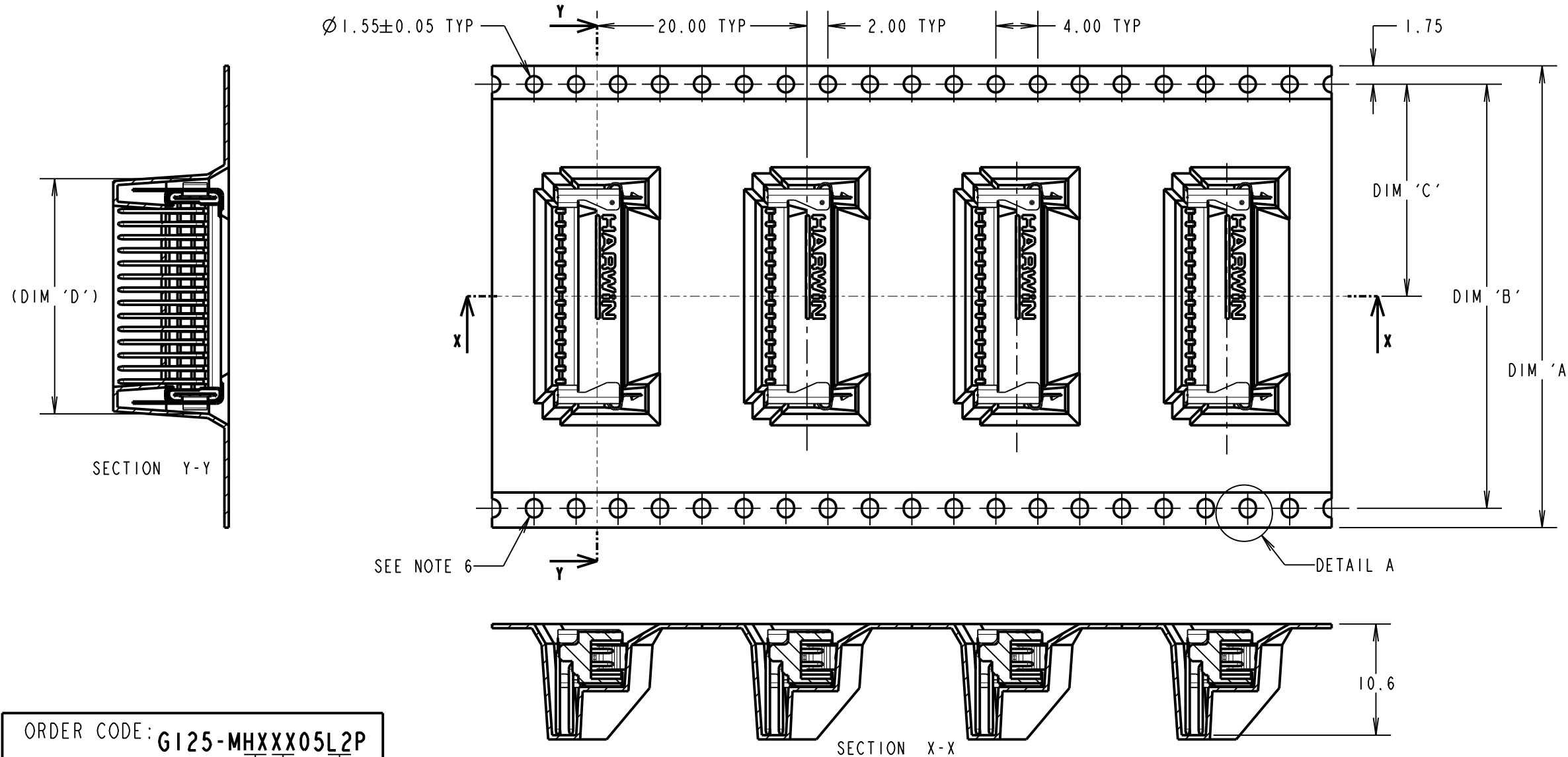

ORDER CODE: **G125-MHXXX05L2P**

CONTACT STYLE: _____
 3.3mm PC-TAIL = H1
 4.8mm PC-TAIL = H2

TOTAL No. OF CONTACTS: _____
 06, 10, 12, 16, 20, 26, 34, 50

LATCHES: _____
 2.5mm BOARD MOUNT & LATCHES = L2

- NOTES:
- COMPONENTS ARE ORIENTED IN TAPE POCKETS AS SHOWN.
 - COMPONENTS ARE SUPPLIED IN STRIPS OF TAPE. SUPPLIED QUANTITY MAY CONSIST OF MORE THAN ONE STRIP. STRIP LENGTH MAY VARY.
 - LARGE QUANTITIES MAY BE SHIPPED ON A REEL AND MAY NOT HAVE A LEADER.
 - FOR COMPLETE SPECIFICATION, SEE COMPONENT SPECIFICATION C125XX (LATEST ISSUE).
 - FOR PARTS ON REEL SUITABLE FOR AUTOMATIC MACHINE PLACEMENT PLEASE ORDER: G125-MHXXX05L2R.
 - ELONGATED SPROCKET HOLE NOT PRESENT ON 06 & 10 POSITIONS.
 - SEE SHEET 5 FOR CONNECTOR DETAILS.

PART No.	DIM 'A'	DIM 'B'	DIM 'C'	DIM 'D'
G125-MHX0605L2P	24.0	NO ELONGATED HOLE	11.50	8.5
G125-MHX1005L2P	+0.3/-0.1			11.0
G125-MHX1205L2P	32.0±0.3	28.40	14.20	12.2
G125-MHX1605L2P				14.7
G125-MHX2005L2P				17.2
G125-MHX2605L2P	44.0±0.3	40.40	20.2±0.15	21.0
G125-MHX3405L2P				26.0
G125-MHX5005L2P	56.0±0.3	52.40	26.2±0.15	36.0

MR	2	08.11.18	20862
NAME	ISS.	DATE	C/NOTE
APPROVED: M.RUDKIN			
CHECKED: M.PLESTED			
DRAWN: MARK G PLESTED			
CUSTOMER REF.:			
ASSEMBLY DRG:			

 www.harwin.com technical@harwin.com	THIS DRAWING AND ANY INFORMATION OR DESCRIPTIVE MATTER SET OUT HEREON ARE CONFIDENTIAL AND COPYRIGHT PROPERTY OF THE HARWIN GROUP AND MUST NOT BE DISCLOSED, LOANED, COPIED OR USED FOR MANUFACTURING, TENDERING OR FOR ANY OTHER PURPOSE WITHOUT THEIR WRITTEN PERMISSION.	TOLERANCES X. = ±1mm X.X = ±0.50mm X.XX = ±0.10mm X.XXX = ±0.01mm ANGLES = ±5° UNLESS STATED	MATERIAL: SEE SHEET 5	TITLE: G125 MALE HORIZONTAL PC TAIL SERIES IN TAPE
		FINISH: SEE SHEET 5 S/AREA: mm ²	DRAWING NUMBER: G125-MHXXX05L2P	SHT 6 OF 6

Customer Information Sheet

DRAWING No.: G125-SERIES COMPONENT SPECIFICATION

IF IN DOUBT - ASK

©

NOT TO SCALE

THIRD ANGLE PROJECTION

ALL DIMENSIONS IN mm

SPECIFICATIONS:

MATERIALS:

MOULDING, PICK & PLACE CAP:
POLYAMIDE, PA4T-GF30 FR(40) UL94V-0,
HALOGEN FREE, FREE OF RED PHOSPHORUS

CONTACTS:

SIGNAL CONTACTS:
MALE PC-TAIL/SMT = PHOSPHOR BRONZE
MALE CRIMP = BRASS
ALL FEMALE CONTACTS = BERYLLIUM COPPER
POWER CONTACTS:
ALL CONTACTS = BERYLLIUM COPPER

LOCKING HARDWARE:

LATCHES: COPPER NICKEL TIN ALLOY
SCREW LOCK: STAINLESS STEEL

BACK POTTING COMPOUND (CABLE ASSEMBLIES ONLY):
STYCAST 2651 MM BACK POTTING WITH CATALYST 9

FINISH:

ALL SIGNAL CONTACTS:
0.2-0.3µm GOLD OVER NICKEL
ALL POWER CONTACTS:
0.76-1.00µm GOLD OVER 1.50-2.50µm NICKEL
AND COPPER FLASH
LATCHES:
3.0µm 100% TIN OVER NICKEL

MECHANICAL:

DURABILITY = 1000 OPERATIONS
RETENTION IN HOUSING (ALL CONTACTS) = 6.0N MIN
SIGNAL CONTACTS:
INSERTION FORCE = 2.8N MAX
WITHDRAWAL FORCE = 0.2N MIN
POWER CONTACTS:
INSERTION FORCE = 7.0N MAX
WITHDRAWAL FORCE = 0.2N MIN
SCREW-LOK:
RETENTION IN HOUSING = 20.0N MIN
LATCHES:
RETENTION IN HOUSING = 4.0N MIN

ENVIRONMENTAL:

CLASSIFICATION: 65/150/56 DAYS AT 93% RH

TEMPERATURE RANGE:

* EIA-364-32 : 2000 TEST CONDITION IV, DWELL
30mins, 5 CYCLES -65°C TO +150°C

MECHANICAL:

VIBRATION AND SHOCK:

* EIA-364-28D : 1999: TEST CONDITION IV: VIBRATION SEVERITY:
10Hz TO 2000Hz, 1.5mm, 198mm/s² (20G). DURATION 2Hr
* EIA-364-28D : 1999: TEST CONDITION IV: VIBRATION SEVERITY:
10Hz TO 2000Hz, 1.5mm, 198mm/s² (20G). DURATION 2Hr
* EIA-364-27B : 1996: TEST CONDITION E SHOCK SEVERITY: 981mm/s²
(100G) FOR 6ms IN Z AXIS, 490mm/s² (50G) FOR 11m/s IN X & Y AXIS.
* EIA-364-01A : 2000: ACCELERATION: 490mm/s² (50G)
* BUMP SEVERITY: 390mm/s² (40G), 4000±10 BUMPS
* TESTED WITH LATCHED CONNECTORS

ELECTRICAL:

CURRENT RATING:

SIGNAL CONTACTS:

EIA-364-70A : 1998: INDIVIDUAL CONTACT IN ISOLATION AT 25°C = 2.8A MAX
EIA-364-70A : 1998: ALL CONTACTS SIMULTANEOUSLY AT 25°C = 2.0A MAX

POWER CONTACTS:

EIA-364-70A : 1998: PER CONTACT, THROUGH ALL CONTACTS = 10A MAX

CONTACT RESISTANCE:

EIA-364-06C : 2006: INITIAL CONTACT RESISTANCE = 20mΩ MAX
EIA-364-06C : 2006: CONTACT RESISTANCE AFTER CONDITIONING = 25mΩ MAX

VOLTAGE PROOF:

EIA-364-20C : 2004: SEA LEVEL (1013mbar) = 600V DC/AC PEAK
EIA-364-20C : 2004: ALTITUDE LEVEL (44mbar, 21,336m/70,000ft) = 350V DC/AC PEAK

WORKING VOLTAGE:

AT SEA LEVEL (1006mbar) = 450V DC/AC PEAK
AT ALTITUDE (44mbar, 21,336m/70,000ft) = 250V DC/AC PEAK

INSULATION RESISTANCE:

EIA-364-21C : 2000: INSULATION RESISTANCE (INITIAL)
= 10GΩ MIN AT 500V DC
EIA-364-21C : 2000: INSULATION RESISTANCE (AFTER CONDITIONING)
= >1GΩ MIN AT 500V DC

FOR FULL COMPONENT SPECIFICATION SEE C125XX (LATEST ISSUE).

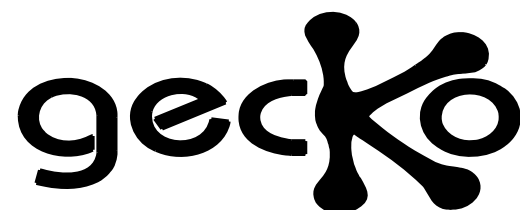

PATENTED TECHNOLOGY

HARWIN

www.harwin.com
technical@harwin.com

THIS DRAWING AND ANY INFORMATION OR DESCRIPTIVE MATTER SET OUT HEREON ARE CONFIDENTIAL AND COPYRIGHT PROPERTY OF THE HARWIN GROUP AND MUST NOT BE DISCLOSED, LOANED, COPIED OR USED FOR MANUFACTURING, TENDERING OR FOR ANY OTHER PURPOSE WITHOUT THEIR WRITTEN PERMISSION.

TOLERANCES

X. = ±1mm
X.X = ±0.50mm
X.XX = ±0.20mm
X.XXX = ±0.01mm
ANGLES = ±5°
UNLESS STATED

MATERIAL:

SEE ABOVE

FINISH:

SEE ABOVE

S/AREA:

mm²

TITLE:

G125 SERIES COMPONENT SPECIFICATION

DRAWING NUMBER:

G125-SERIES CONNECTORS

SHT
1
OF
1

RTP	5	04.10.19	22083
NAME	ISS.	DATE	C/NOTE
APPROVED:		R.PORTLOCK	
CHECKED:		S.BENNETT	
DRAWN:		S.FLOWER	
CUSTOMER REF.:			
ASSEMBLY DRG:			



Компания «ЭлектроПласт» предлагает заключение долгосрочных отношений при поставках импортных электронных компонентов на взаимовыгодных условиях!

Наши преимущества:

- Оперативные поставки широкого спектра электронных компонентов отечественного и импортного производства напрямую от производителей и с крупнейших мировых складов;
- Поставка более 17-ти миллионов наименований электронных компонентов;
- Поставка сложных, дефицитных, либо снятых с производства позиций;
- Оперативные сроки поставки под заказ (от 5 рабочих дней);
- Экспресс доставка в любую точку России;
- Техническая поддержка проекта, помощь в подборе аналогов, поставка прототипов;
- Система менеджмента качества сертифицирована по Международному стандарту ISO 9001;
- Лицензия ФСБ на осуществление работ с использованием сведений, составляющих государственную тайну;
- Поставка специализированных компонентов (Xilinx, Altera, Analog Devices, Intersil, Interpoint, Microsemi, Aeroflex, Peregrine, Syfer, Eurofarad, Texas Instrument, Miteq, Cobham, E2V, MA-COM, Hittite, Mini-Circuits, General Dynamics и др.);

Помимо этого, одним из направлений компании «ЭлектроПласт» является направление «Источники питания». Мы предлагаем Вам помощь Конструкторского отдела:

- Подбор оптимального решения, техническое обоснование при выборе компонента;
- Подбор аналогов;
- Консультации по применению компонента;
- Поставка образцов и прототипов;
- Техническая поддержка проекта;
- Защита от снятия компонента с производства.



Как с нами связаться

Телефон: 8 (812) 309 58 32 (многоканальный)

Факс: 8 (812) 320-02-42

Электронная почта: org@eplast1.ru

Адрес: 198099, г. Санкт-Петербург, ул. Калинина, дом 2, корпус 4, литера А.