

Plug - QP 1,5/ 1-M BU - 3051056

Please be informed that the data shown in this PDF Document is generated from our Online Catalog. Please find the complete data in the user's documentation. Our General Terms of Use for Downloads are valid (<http://phoenixcontact.com/download>)



Plug, Connection method: Quick connection, Number of positions: 1, Cross section: 0.25 mm² - 1.5 mm², AWG: 24 - 16, Width: 5.2 mm, Height: 40 mm, Color: blue

Illustration shows various versions of the product (left, center and right element) in different color combinations

Product Description

Connector element center, left housing with engagement pin, right opened without cover

Product Features

- The conductor is connected using the familiar IDC connection with no stripping, therefore saving time
- The QT-COMBI plugs for self-assembly provide solutions that users can implement themselves
- Tested for railway applications
- The QP 1,5/... fast connector plug is designed for the connection of solid and stranded conductors



Key Commercial Data

Packing unit	1 pc
Minimum order quantity	50 pc
Weight per Piece (excluding packing)	4.31 g
Custom tariff number	85366990
Country of origin	Turkey

Technical data

General

Number of levels	1
Number of connections	1
Nominal cross section	1.5 mm ²
Color	blue
Insulating material	PA

Plug - QP 1,5/ 1-M BU - 3051056

Technical data

General

Flammability rating according to UL 94	V0
Area of application	Railway industry
	Machine building
	Plant engineering
Maximum load current	17.5 A (with 1.5 mm ² conductor cross section)
Rated surge voltage	6 kV
Degree of pollution	3
Overvoltage category	III
Insulating material group	I
Maximum load current	17.5 A (with 1.5 mm ² conductor cross section)
Nominal current I _N	17.5 A
Nominal voltage U _N	500 V

Dimensions

Width	5.2 mm
Length	20 mm
Height	40 mm
	24.00 mm
Pitch	5.20 mm

Connection data

Connection method	Quick connection
Connection in acc. with standard	IEC 61984
Conductor cross section solid min.	0.25 mm ²
Conductor cross section solid max.	1.5 mm ²
Conductor cross section AWG min.	24
Conductor cross section AWG max.	16
Conductor cross section flexible min.	0.25 mm ²
Conductor cross section flexible max.	1.5 mm ²
Min. AWG conductor cross section, flexible	24
Max. AWG conductor cross section, flexible	16
Material wire insulation	PVC / PE
Structure of individual litz in acc. with VDE 0295 / smallest wire diameter	VDE 0295 Cl.1-5
Max. wire diameter incl. insulation	3 mm

Standards and Regulations

Connection in acc. with standard	CSA
	IEC 61984

Plug - QP 1,5/ 1-M BU - 3051056

Technical data

Standards and Regulations

Flammability rating according to UL 94	V0
--	----

Classifications

eCl@ss

eCl@ss 4.0	272607xx
eCl@ss 4.1	27260701
eCl@ss 5.0	27260701
eCl@ss 5.1	27260701
eCl@ss 6.0	27141120
eCl@ss 7.0	27141120
eCl@ss 8.0	27141151
eCl@ss 9.0	27141151

ETIM

ETIM 2.0	EC000897
ETIM 3.0	EC000897
ETIM 4.0	EC002021
ETIM 5.0	EC002021

UNSPSC

UNSPSC 6.01	30211802
UNSPSC 7.0901	39121402
UNSPSC 11	39121402
UNSPSC 12.01	39121402
UNSPSC 13.2	39121402

Approvals

Approvals

Approvals

CSA / UL Recognized / cUL Recognized / GL / EAC / EAC / cULus Recognized

Ex Approvals

Plug - QP 1,5/ 1-M BU - 3051056

Approvals

Approvals submitted

Approval details

CSA

	B	C	D
mm ² /AWG/kcmil	24-16	24-16	24-16
Nominal current I _N	10 A	10 A	5 A
Nominal voltage U _N	300 V	300 V	600 V

UL Recognized

	B	C	D
mm ² /AWG/kcmil	24-16	24-16	24-16
Nominal current I _N	10 A	10 A	5 A
Nominal voltage U _N	600 V	300 V	600 V

cUL Recognized

	B	C	D
mm ² /AWG/kcmil	24-12	24-12	24-12
Nominal current I _N	10 A	10 A	5 A
Nominal voltage U _N	600 V	300 V	600 V

GL

EAC

EAC

cULus Recognized

Plug - QP 1,5/ 1-M BU - 3051056

Accessories

Accessories

Insulating sleeve

Insulating sleeve - MPS-IH WH - 0201663



Insulating sleeve, Color: white

Insulating sleeve - MPS-IH RD - 0201676



Insulating sleeve, Color: red

Insulating sleeve - MPS-IH BU - 0201689



Insulating sleeve, Color: blue

Insulating sleeve - MPS-IH YE - 0201692



Insulating sleeve, Color: yellow

Insulating sleeve - MPS-IH GN - 0201702



Insulating sleeve, Color: green

Plug - QP 1,5/ 1-M BU - 3051056

Accessories

Insulating sleeve - MPS-IH GY - 0201728



Insulating sleeve, Color: gray

Insulating sleeve - MPS-IH BK - 0201731



Insulating sleeve, Color: black

Partition plate

Spacer plate - DP PS-5 - 3036725



Spacer plate, Length: 22.4 mm, Width: 5.2 mm, Height: 29 mm, Number of positions: 1, Color: red

Screwdriver tools

Screwdriver - SZF 1-0,6X3,5 - 1204517



Actuation tool, for ST terminal blocks, also suitable for use as a bladed screwdriver, size: 0.6 x 3.5 x 100 mm, 2-component grip, with non-slip grip

Test plug terminal block

Plug - QP 1,5/ 1-M BU - 3051056

Accessories

Reducing plug - RPS - 0201647



Reducing plug, Color: gray

Test plugs - MPS-MT - 0201744



Test plugs, Color: silver

Test plugs - PS-5 - 3030983



Test plugs, Color: red

Test plugs - PS-5/2,3MM RD - 3038723



Test plugs, Color: red

Drawings

Plug - QP 1,5/ 1-M BU - 3051056

Circuit diagram



Diagram

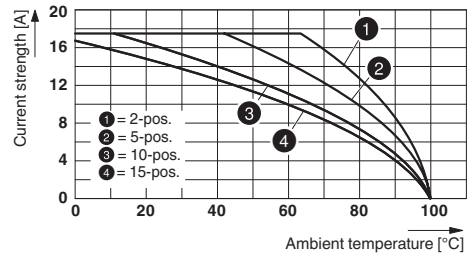

Schematic diagram

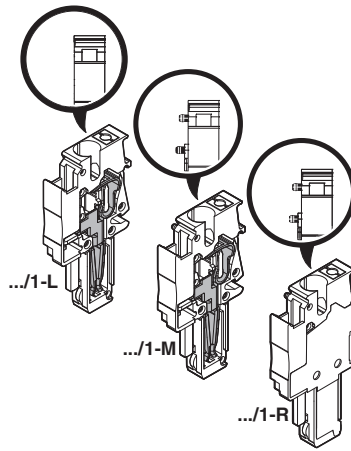



Компания «ЭлектроПласт» предлагает заключение долгосрочных отношений при поставках импортных электронных компонентов на взаимовыгодных условиях!

Наши преимущества:

- Оперативные поставки широкого спектра электронных компонентов отечественного и импортного производства напрямую от производителей и с крупнейших мировых складов;
- Поставка более 17-ти миллионов наименований электронных компонентов;
- Поставка сложных, дефицитных, либо снятых с производства позиций;
- Оперативные сроки поставки под заказ (от 5 рабочих дней);
- Экспресс доставка в любую точку России;
- Техническая поддержка проекта, помощь в подборе аналогов, поставка прототипов;
- Система менеджмента качества сертифицирована по Международному стандарту ISO 9001;
- Лицензия ФСБ на осуществление работ с использованием сведений, составляющих государственную тайну;
- Поставка специализированных компонентов (Xilinx, Altera, Analog Devices, Intersil, Interpoint, Microsemi, Aeroflex, Peregrine, Syfer, Eurofarad, Texas Instrument, Miteq, Cobham, E2V, MA-COM, Hittite, Mini-Circuits, General Dynamics и др.);

Помимо этого, одним из направлений компании «ЭлектроПласт» является направление «Источники питания». Мы предлагаем Вам помощь Конструкторского отдела:

- Подбор оптимального решения, техническое обоснование при выборе компонента;
- Подбор аналогов;
- Консультации по применению компонента;
- Поставка образцов и прототипов;
- Техническая поддержка проекта;
- Защита от снятия компонента с производства.



Как с нами связаться

Телефон: 8 (812) 309 58 32 (многоканальный)

Факс: 8 (812) 320-02-42

Электронная почта: org@eplast1.ru

Адрес: 198099, г. Санкт-Петербург, ул. Калинина, дом 2, корпус 4, литера А.