

Universal AC Input Module

Features & Benefits

- Universal input (85 to 264 Vac, 47 to 63 Hz)
- Chassis Mount or PCB Mount Form Factor
- Small robust package
- Low profile
- EMI filtering
- Meets EN61000-4-5 Class 3 surge protection when used with external MOV and paired with Vicor PFM4414 products

Product Description

The AIM in a VIA Package (AC Input Module) is a front end module designed to interface directly with worldwide AC mains and provide a rectified AC input to Vicor's family of VIA PFM4414 products. The AIM combines a bridge rectifier, EMI filter, and surge protection circuitry in an easy to use VIA plastic housing. Together, the AIM and PFM in a VIA Package realize a small, efficient, simple, and cost effective EMI Class B AC-DC solution for a broad range of end applications.

Typical Applications

- Small cell base stations
- Telecom switching equipment
- LED lighting
- Test and Measurement Equipment
- 200 – 400 W Industrial Power Systems
- Office Equipment



Size:
1.74 x 1.40 x .37 in
44.2 x 35.5 x 9.3 mm

Part Ordering Information

Product Function	Package Length	Package Width	Package Type	Input Voltage	Range Ratio	Output Voltage (Range)	Max Output Power	Product Grade	Option Field	
AIM	17	14	x	B6	M	C7	D5	y	z	z
AIM = AC Input Module	Length in Inches x 10	Width in Inches x 10	B = Board VIA V = Chassis VIA	Internal Reference				C = -20 to 100°C T = -40 to 100°C	00 = Chassis/Always On 04 = Short Pin/Always On 08 = Long Pin/Always On	

Typical PCB Mount Applications

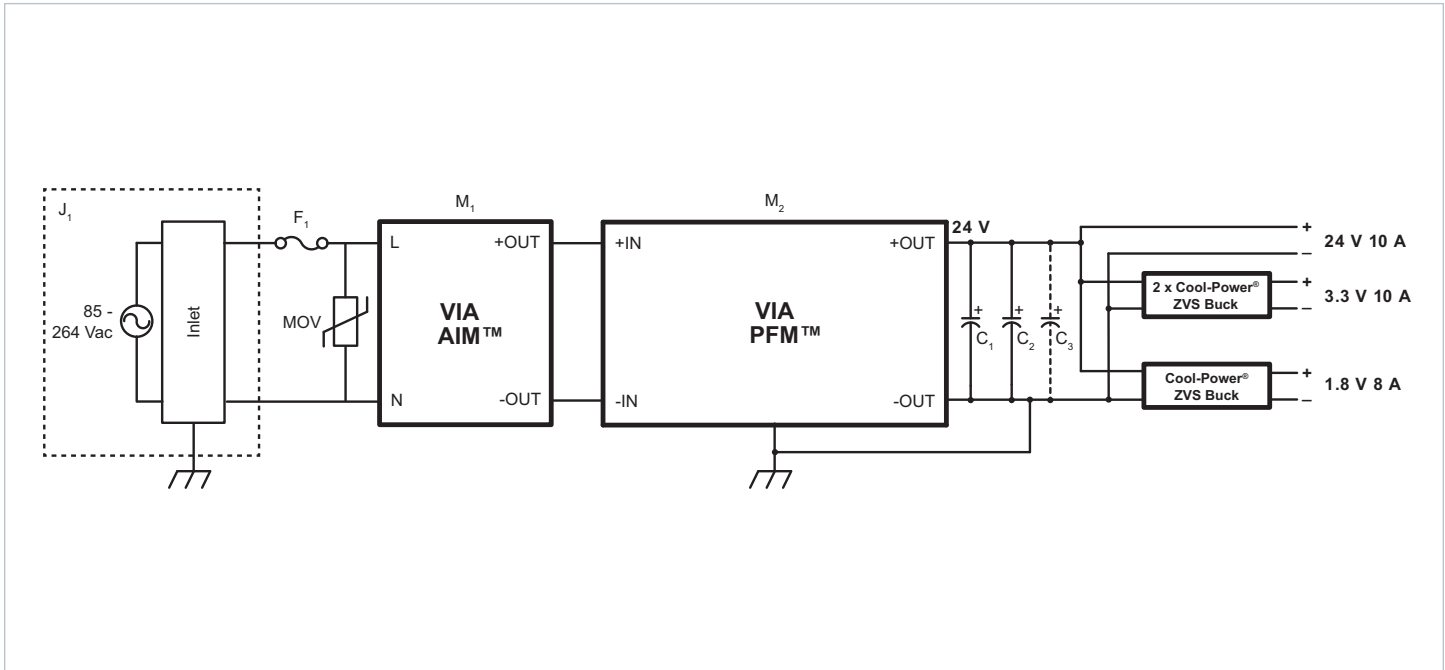

The PCB terminal option allows mounting on an industry standard printed circuit board, with two different pin lengths.

Parts List for Typical PCB Mount Applications

J1	Qualtek 703 W IEC 320-C14 Power Inlet
F1	Littelfuse 0216008.MXP 8 A 250 VAC 5 x 20 mm holder
M1	Vicor AIM™ AIM1714BB6MC7D5yzz
M2	Vicor PFM™ PFM4414BB6M24D0yzz
C1, C2, (C3)	Nichicon UVR1V153MRD 15,000 μ F 35 V 4.3 A 25 x 50 mm bent 90°, x 3 pcs or
	CDE 380LX153M035A022 15,000 μ F 35 V 5.6 A 35 x 30 mm snap in, x 3 pcs or
	Sic Safco Cubic LP A712062 22,000 μ F 35 V 5.8 A 45 x 75 x 12 mm rectangular, x 2 pcs
MOV	Littelfuse TMOV20RP300E VARISTOR 10 kA 300 V 250 J 20 mm

Typical Chassis Mount Applications

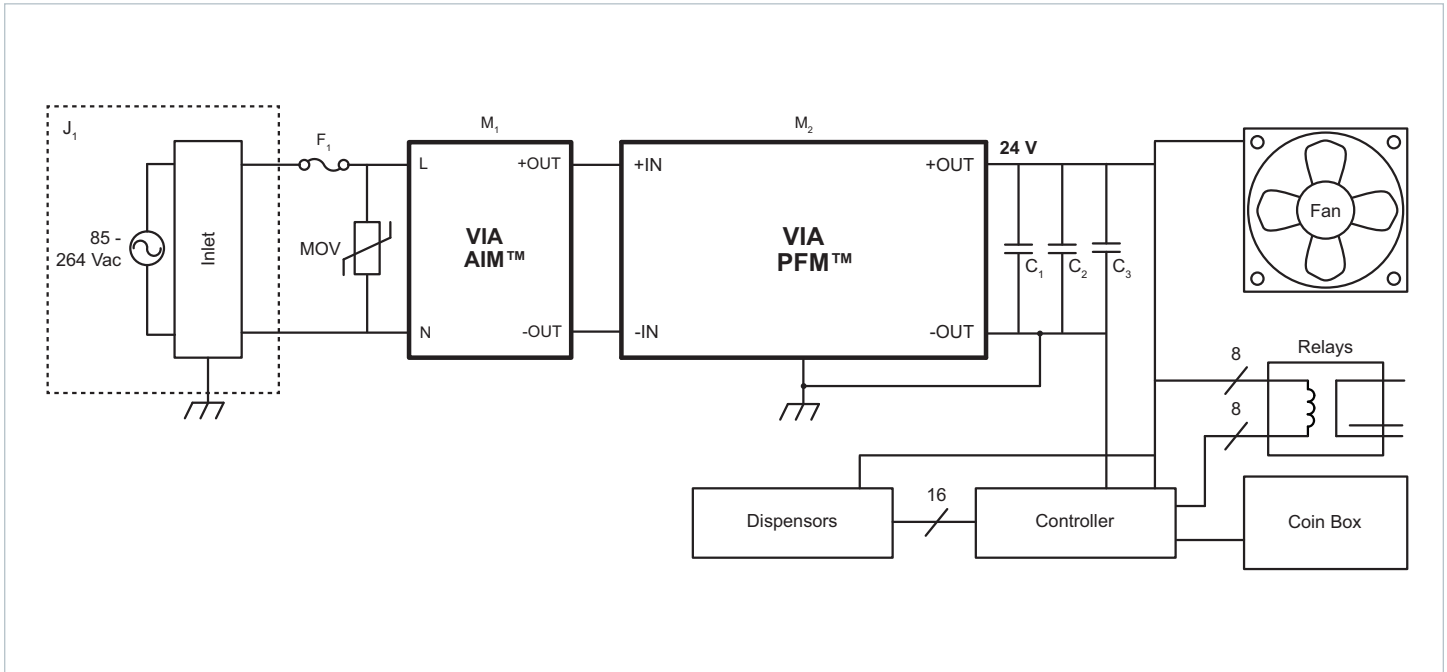

The VIA AIM and VIA PFM are available in Chassis Mount option, saving the cost of a PCB and allowing access to both sides of the power supply for cooling. The parts list below minimizes the number of interconnects required between necessary components, and selects components with terminals traditionally used for point to point chassis wiring.

Parts List for Typical Chassis Mount Applications	
J1	Qualtek 719 W or 723 W IEC 320-C14 Power Inlet
F1	Littelfuse 0216008.MXP 8 A 250 VAC 5 x 20 mm in a J1, or separate fuse holder
M1	Vicor AIM™ AIM1714VB6MC7D5y00
M2	Vicor PFM™ PFM4414VB6M24D0y00
C1, C2, C3	Nichicon LNT1V153MSE 15,000 µF 35 V 5.1 A 35 x 83 mm screw terminal or
C1	Kemet ALS30A473KE040 47,000 µF 40 V 14.2 A 51 x 84 mm screw terminal
MOV	Littelfuse TMOV20RP300E VARISTOR 10 kA 300 V 250 J 20 mm

Pin Configuration

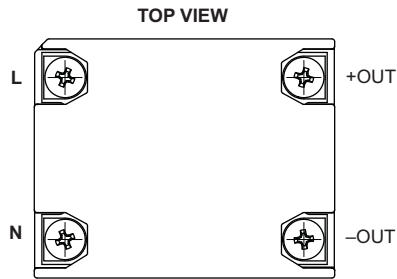

1714 VIA AIM - Chassis Mount - Terminals Up

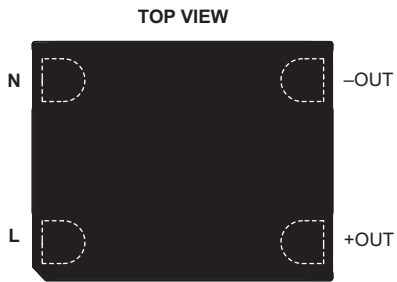

1714 VIA AIM - PCB Mount - Pins Down

Please note that these Pin drawings are not to scale.

Pin Descriptions

Signal Name	Type	Function
N	INPUT POWER RETURN	AC Neutral / Line 2 input
L	INPUT POWER	AC Line1 input
-OUT	OUTPUT POWER RETURN	Negative output power terminal
+OUT	OUTPUT POWER	Positive output power terminal

Absolute Maximum Ratings

The absolute maximum ratings below are stress ratings only. Operation at or beyond these maximum ratings can cause permanent damage to the device.

Parameter	Comments	Min	Max	Unit
Input voltage pp at terminals, 1ms max		0	600	Vpk
Input voltage (AC RMS) continuous		0	275	V _{RMS}
Output current (continuous)		0	5.3	A _{RMS}
Operating junction temperature		-40	125	°C
Storage temperature		-40	125	°C
Input/Output pin torque and mounting torque			4 (0.45)	in/lbs (N-m)

Electrical Specifications

Specifications apply over all line and load conditions, 50 Hz and 60 Hz line frequencies, $T_J = 25^\circ\text{C}$, unless otherwise noted.

Boldface specifications apply over the temperature range of the specified product grade.

Attribute	Symbol	Conditions / Notes	Min	Typ	Max	Unit
Input Specification						
Input voltage range, continuous operation	V_{IN}		85		264	V_{RMS}
Input voltage range, transient, non-operational (peak), 30s minimum interval	V_{IN}				600	V
Source line frequency range	f_{line}		47		63	Hz
Power factor*	PF	See note below				-
Output Specification						
Output power	P_{OUT}				450	W
Output Current (continuous)	I_{OUT}				5.3	A

* Please see PFM in VIA package datasheet for power factor

Block Diagram

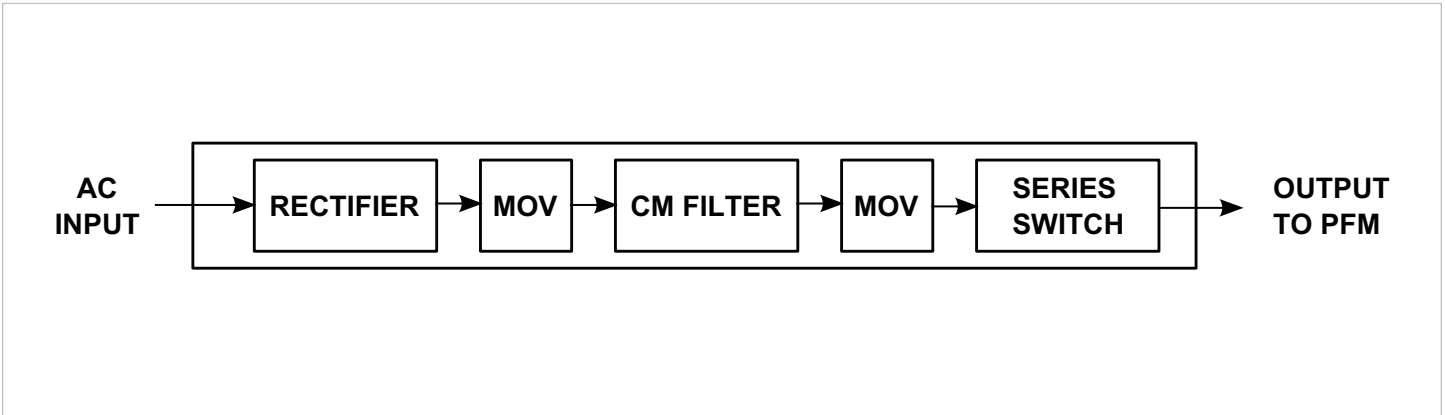

Application Characteristics

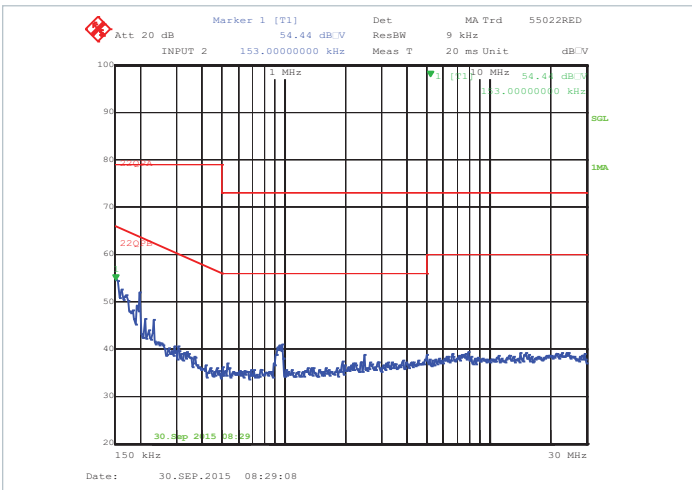

Figure 1 — Typical conducted emissions, peak scan, with VIA PFM4414, 115V, 90% load with VIA PFM -Out connected to GND

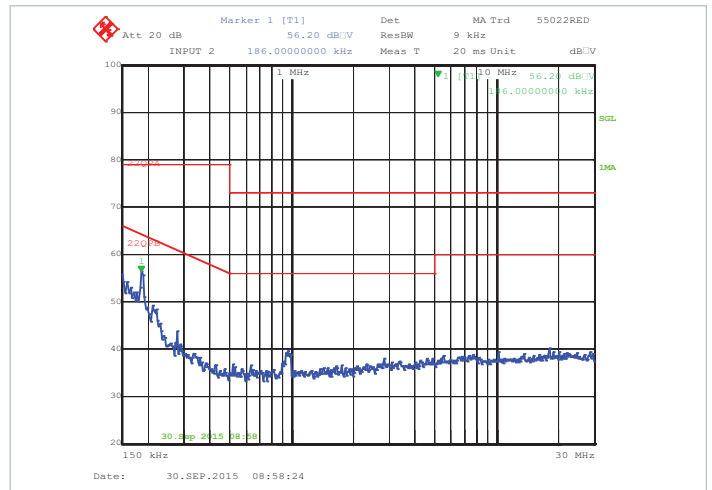

Figure 2 — Typical conducted emissions, peak scan, with VIA PFM4414, 230V, 90% load with VIA PFM -Out connected to GND

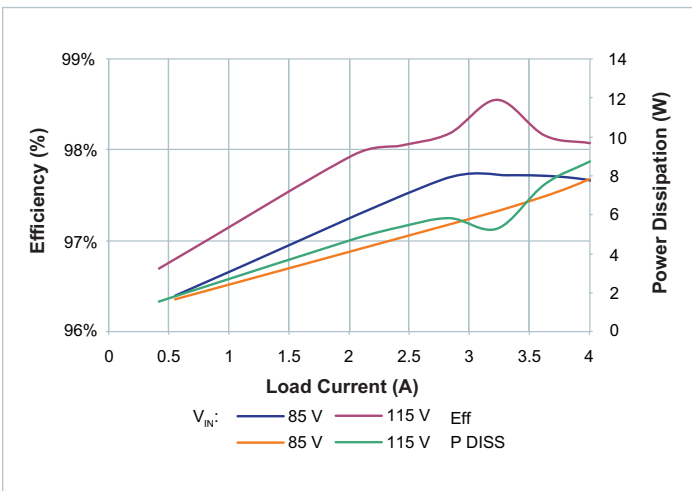

Figure 3 — V_{IN} to V_{OUT} efficiency and power dissipation vs. V_{IN} and I_{OUT} , $T_{CASE} = 20^{\circ}C$

General Characteristics

Specifications apply over all line and load conditions, 50 Hz and 60 Hz line frequencies, TC = 25°C, unless otherwise noted.

Boldface specifications apply over the temperature range of the specified Product Grade.

Attribute	Symbol	Conditions / Notes	Min	Typ	Max	Unit
Mechanical						
Length	L			44.20 / [1.74]		mm / [in]
Width	W			35.5 / [1.40]		mm / [in]
Height	H			9.22 / [0.36]		mm / [in]
Volume	Vol	Without heatsink		14.5 / [0.88]		cm ³ / [in ³]
Pin material		C145 copper, half hard				
Underplate		Low stress ductile nickel	50		100	µin
Pin finish		Palladium	0.8		6	µin
		Soft Gold	0.12		2	µin
Thermal						
Operating case temperature	T _C	C - Grade	-20		100	°C
		T - Grade	-40		100	°C
Thermal resistance, junction to case bottom	R _{JC_BOT}			2.2		°C/W
Thermal design		See Thermal Considerations on Page 10				
Reliability						
MTBF		MIL-HDBK-217FN2 Parts Count - 25°C Ground Benign, Stationary, Indoors / Computer		8.2		MHrs
		Telcordia Issue 2 - Method I Case III; 25°C		28.6		
		MIL-HDBK-217FN2 - 25°C Ground Benign, Stationary, Indoors / Computer		7.4		
Safety						
Agency approvals/standards		EN60950-1; CE marked for low voltage directive and RoHS recast directive, as applicable				
Dielectric withstand (hipot)		In / Out to Case	1500			Vac
EMI/EMC Compliance						
FCC Part 15, EN55022, CISPR22: 2006 + A1: 2007, Conducted Emissions		Class B Limits - with VIA PFM -OUT connected to GND				
EN61000-4-5: 2006, Surge Immunity		Level 3, Immunity Criteria A with PFM in a VIA Package with external TMOV				

Environmental Qualification

Testing Activity	Reference Standard	Test Details
High Temperature Operating Bias/Life (HTOB/HTOL)	JESD22-A108D	1000 hrs. Nominal Full Load at Max operating temperature
Temperature Cycling Test (TCT)	IPC-9592B	125°C to -40°C, 700 cycles
Temperature Humidity Bias (THB)	JESD22-A101C	1000 hrs. Nominal Input voltage, Minimal load 85°C, 85% RH
High Temperature Storage (HTS)	JESD22-A103D	1000 hrs. 125°C
Low Temperature Storage (LTS)	JESD22-A119	1000 hrs. -65°C
Random Vibration	MIL-STD-810G	Method 514.6, Procedure I, Category 24, 20-2000 Hz, @7.7 Grms, 1hour /axis for 3 axis. Product mounted on an evaluation board, nominal line 50% load.
Mechanical Shock	MIL-STD-810G	Method 516.5, Procedure I, Functional shock 40 G, total of 18 shocks. Product mounted on an evaluation board, nominal Line 50% load.
Highly Accelerated Life Test (HALT)	Internal Vicor Procedure - DP-0265	Low and high temperature tests, rapid thermal cycling, random vibration testing, combined stress testing and destruct testing.
Res. Solvents	MIL-STD-202G	Method 215 K, 3 minutes exposure
ESD Human Body Model	JEDEC JS-001-2012	Class 1C (HBM) Minimum
ESD Charged Device Model	JESD22-C101E	Class II (CDM) Minimum

Thermal Considerations

The AIM in a VIA package can be cooled using Single side cooling. Since the AIM has a maximum internal temperature rating, it is necessary to estimate this internal temperature based on a system-level thermal solution. To this purpose, it is helpful to simplify the thermal solution into a roughly equivalent circuit where power dissipation is modeled as a current source, isothermal surface temperatures are represented as voltages sources, and thermal resistances are represented as resistors. Figure 4 shows the bottom side cooling “thermal circuit” for the AIM in VIA package:

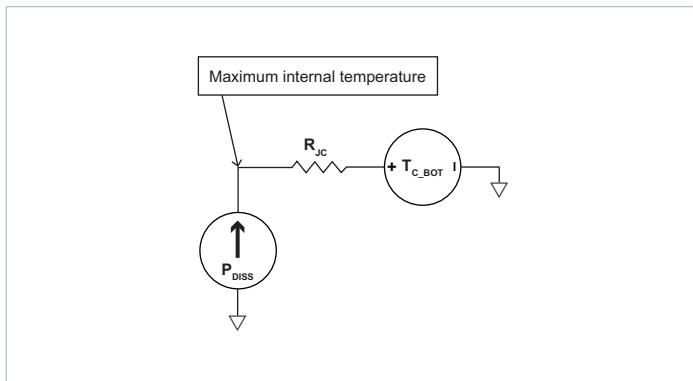
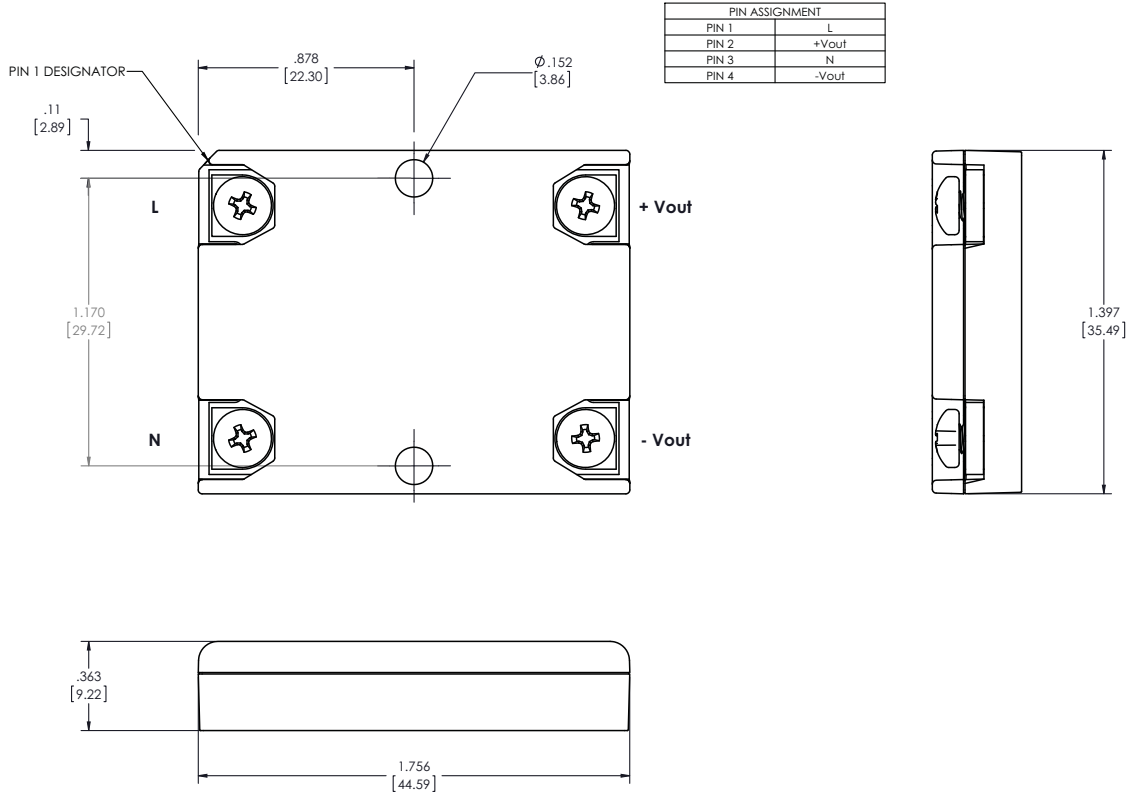

Figure 4 – Bottom-side cooling VIA thermal model

The internal power dissipation is P_{DISS} , R_{JC_BOT} is the thermal resistance characteristic of the VIA package and the bottom surface temperature is represented as T_{c_BOT} . The AIM is best attached to a material with high thermal conductivity (e.g. aluminum or copper) to maintain temperature uniformity across the bottom side.

AIM in a VIA Package Chassis Mount Package Mechanical Drawing



NOTE:
1. RoHS COMPLIANT PER CST-0001 LATEST REVISION.

Product outline drawing; Product outline drawings are available in .pdf and .dxf formats.
3D mechanical models are available in .pdf and .step formats.

AIM in a VIA Package Board Mount Package Mechanical Drawing

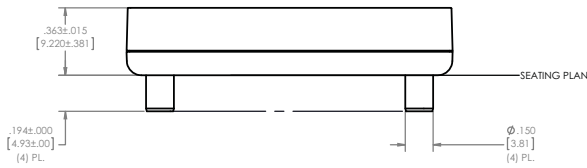
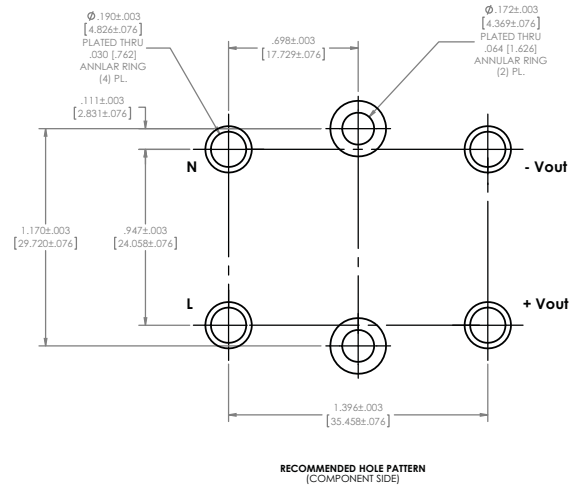
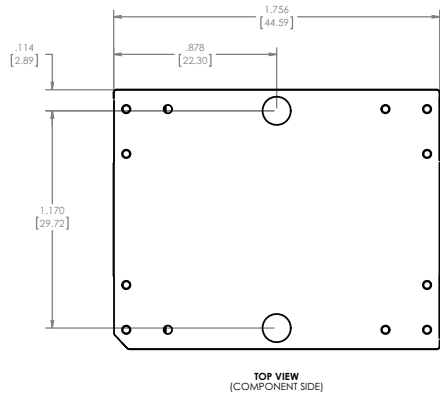

PIN ASSIGNMENT	
PIN 1	L
PIN 2	+Vout
PIN 3	N
PIN 4	-Vout

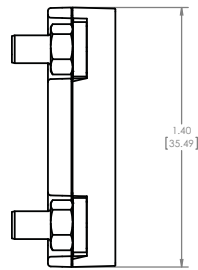
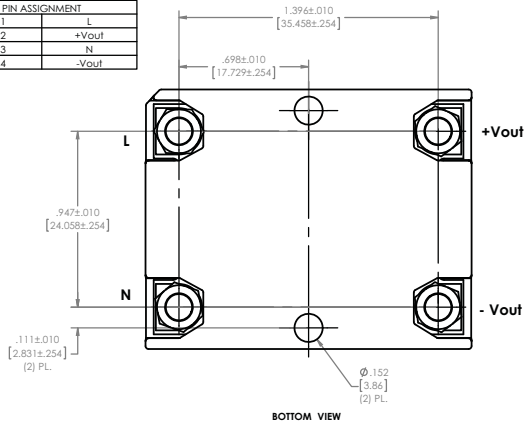

Revision History

Revision	Date	Description	Page Number(s)
1.0	12/24/15	Intitial release	n/a

Vicor's comprehensive line of power solutions includes high density AC-DC and DC-DC modules and accessory components, fully configurable AC-DC and DC-DC power supplies, and complete custom power systems.

Information furnished by Vicor is believed to be accurate and reliable. However, no responsibility is assumed by Vicor for its use. Vicor makes no representations or warranties with respect to the accuracy or completeness of the contents of this publication. Vicor reserves the right to make changes to any products, specifications, and product descriptions at any time without notice. Information published by Vicor has been checked and is believed to be accurate at the time it was printed; however, Vicor assumes no responsibility for inaccuracies. Testing and other quality controls are used to the extent Vicor deems necessary to support Vicor's product warranty. Except where mandated by government requirements, testing of all parameters of each product is not necessarily performed.

Specifications are subject to change without notice.

Vicor's Standard Terms and Conditions

All sales are subject to Vicor's Standard Terms and Conditions of Sale, which are available on Vicor's webpage or upon request.

Product Warranty

In Vicor's standard terms and conditions of sale, Vicor warrants that its products are free from non-conformity to its Standard Specifications (the "Express Limited Warranty"). This warranty is extended only to the original Buyer for the period expiring two (2) years after the date of shipment and is not transferable.

UNLESS OTHERWISE EXPRESSLY STATED IN A WRITTEN SALES AGREEMENT SIGNED BY A DULY AUTHORIZED VICOR SIGNATORY, VICOR DISCLAIMS ALL REPRESENTATIONS, LIABILITIES, AND WARRANTIES OF ANY KIND (WHETHER ARISING BY IMPLICATION OR BY OPERATION OF LAW) WITH RESPECT TO THE PRODUCTS, INCLUDING, WITHOUT LIMITATION, ANY WARRANTIES OR REPRESENTATIONS AS TO MERCHANTABILITY, FITNESS FOR PARTICULAR PURPOSE, INFRINGEMENT OF ANY PATENT, COPYRIGHT, OR OTHER INTELLECTUAL PROPERTY RIGHT, OR ANY OTHER MATTER.

This warranty does not extend to products subjected to misuse, accident, or improper application, maintenance, or storage. Vicor shall not be liable for collateral or consequential damage. Vicor disclaims any and all liability arising out of the application or use of any product or circuit and assumes no liability for applications assistance or buyer product design. Buyers are responsible for their products and applications using Vicor products and components. Prior to using or distributing any products that include Vicor components, buyers should provide adequate design, testing and operating safeguards.

Vicor will repair or replace defective products in accordance with its own best judgment. For service under this warranty, the buyer must contact Vicor to obtain a Return Material Authorization (RMA) number and shipping instructions. Products returned without prior authorization will be returned to the buyer. The buyer will pay all charges incurred in returning the product to the factory. Vicor will pay all reshipment charges if the product was defective within the terms of this warranty.

Life Support Policy

VICOR'S PRODUCTS ARE NOT AUTHORIZED FOR USE AS CRITICAL COMPONENTS IN LIFE SUPPORT DEVICES OR SYSTEMS WITHOUT THE EXPRESS PRIOR WRITTEN APPROVAL OF THE CHIEF EXECUTIVE OFFICER AND GENERAL COUNSEL OF VICOR CORPORATION. As used herein, life support devices or systems are devices which (a) are intended for surgical implant into the body, or (b) support or sustain life and whose failure to perform when properly used in accordance with instructions for use provided in the labeling can be reasonably expected to result in a significant injury to the user. A critical component is any component in a life support device or system whose failure to perform can be reasonably expected to cause the failure of the life support device or system or to affect its safety or effectiveness. Per Vicor Terms and Conditions of Sale, the user of Vicor products and components in life support applications assumes all risks of such use and indemnifies Vicor against all liability and damages.

Intellectual Property Notice

Vicor and its subsidiaries own Intellectual Property (including issued U.S. and Foreign Patents and pending patent applications) relating to the products described in this data sheet. No license, whether express, implied, or arising by estoppel or otherwise, to any intellectual property rights is granted by this document. Interested parties should contact Vicor's Intellectual Property Department.

The products described on this data sheet are protected by the following U.S. Patents Numbers: Patents Pending.

Vicor Corporation

25 Frontage Road
Andover, MA, USA 01810
Tel: 800-735-6200
Fax: 978-475-6715

email

Customer Service: custserv@vicorpower.com
Technical Support: apps@vicorpower.com

Mouser Electronics

Authorized Distributor

Click to View Pricing, Inventory, Delivery & Lifecycle Information:

[Vicor:](#)

[AIM1714BB6MC7D5T04](#) [AIM1714BB6MC7D5C04](#) [AIM1714BB6MC7D5C08](#) [AIM1714BB6MC7D5T08](#)
[AIM1714VB6MC7D5T00](#) [AIM1714VB6MC7D5C00](#)



Компания «ЭлектроПласт» предлагает заключение долгосрочных отношений при поставках импортных электронных компонентов на взаимовыгодных условиях!

Наши преимущества:

- Оперативные поставки широкого спектра электронных компонентов отечественного и импортного производства напрямую от производителей и с крупнейших мировых складов;
- Поставка более 17-ти миллионов наименований электронных компонентов;
- Поставка сложных, дефицитных, либо снятых с производства позиций;
- Оперативные сроки поставки под заказ (от 5 рабочих дней);
- Экспресс доставка в любую точку России;
- Техническая поддержка проекта, помощь в подборе аналогов, поставка прототипов;
- Система менеджмента качества сертифицирована по Международному стандарту ISO 9001;
- Лицензия ФСБ на осуществление работ с использованием сведений, составляющих государственную тайну;
- Поставка специализированных компонентов (Xilinx, Altera, Analog Devices, Intersil, Interpoint, Microsemi, Aeroflex, Peregrine, Syfer, Eurofarad, Texas Instrument, Miteq, Cobham, E2V, MA-COM, Hittite, Mini-Circuits, General Dynamics и др.);

Помимо этого, одним из направлений компании «ЭлектроПласт» является направление «Источники питания». Мы предлагаем Вам помощь Конструкторского отдела:

- Подбор оптимального решения, техническое обоснование при выборе компонента;
- Подбор аналогов;
- Консультации по применению компонента;
- Поставка образцов и прототипов;
- Техническая поддержка проекта;
- Защита от снятия компонента с производства.



Как с нами связаться

Телефон: 8 (812) 309 58 32 (многоканальный)

Факс: 8 (812) 320-02-42

Электронная почта: org@eplast1.ru

Адрес: 198099, г. Санкт-Петербург, ул. Калинина, дом 2, корпус 4, литера А.