

## DESCRIPTION

The MP3394S is a step-up controller with 4 current channels. It's designed to drive WLED arrays for large-size LCD-panel backlighting applications. The MP3394S is flexible, and can expand the number of LED channels with 1 or 2 MP3394S in parallel operating from a single inductive power source.

The MP3394S uses an architecture of current – mode and fixed operation frequency. The frequency is programmable by an external frequency-setting resistor. MP3394S drives an external MOSFET to boost up the output voltage from a 5V to 28V input supply. It regulates the current in each LED string to the programmed value set by an external current-setting resistor.

The MP3394S applies 4 internal current sources for current balance. The current matching can achieve 2.5% regulation accuracy between strings. Its low regulation voltage on LED current sources reduces power loss and improves efficiency.

An external PWM input signal or DC input signal controls PWM dimming. In DC-input dimming mode, the dimming PWM signal can be generated internally and the dimming frequency is programmed by an external setting capacitor.

## FEATURES

- 4-String, Max 200mA/String WLED Driver
- 5V to 28V Input Voltage Range
- 2.5% Current Matching Accuracy Between Strings
- Programmable Switching Frequency
- PWM or DC Input Burst PWM Dimming
- Open and Short LED Protection
- Programmable Over-Voltage Protection
- Cascading Capability with a Single Power Source
- Under-Voltage Lockout
- Thermal Shutdown
- TSSOP16EP, SOIC16 and SOIC20 Packages

## APPLICATIONS

- Desktop LCD Flat Panel Displays
- Flat Panel Video Displays
- 2D/3D LCD TVs and Monitors

All MPS parts are lead-free and adhere to the RoHS directive. For MPS green status, please visit MPS website under Quality Assurance. "MPS" and "The Future of Analog IC Technology" are Registered Trademarks of Monolithic Power Systems, Inc.

## TYPICAL APPLICATION

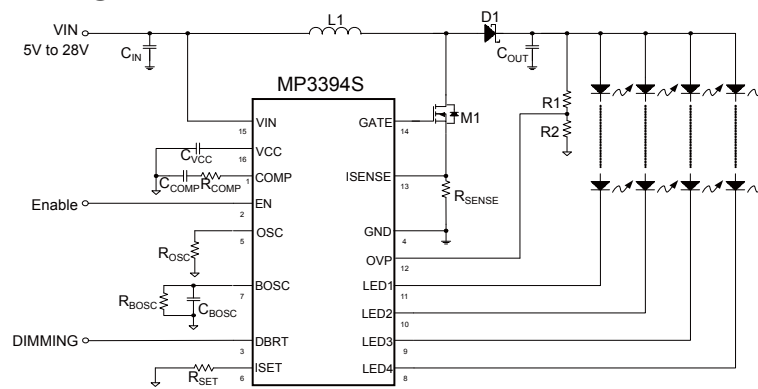

### ORDERING INFORMATION

| Part Number  | Package   | Top Marking |
|--------------|-----------|-------------|
| MP3394SGF*   | TSSOP16EP | MP3394S     |
| MP3394SGS**  | SOIC16    | MP3394S     |
| MP3394SGY*** | SOIC20    | MP3394S     |

\*For Tape & Reel, add suffix -Z (eg. MP3394SGF-Z).

\*\*For Tape & Reel, add suffix -Z (eg. MP3394SGS-Z).

\*\*\*For Tape & Reel, add suffix -Z (eg. MP3394SGY-Z).

Contact Factory for TSSOP16EP Availability

### PACKAGE REFERENCE

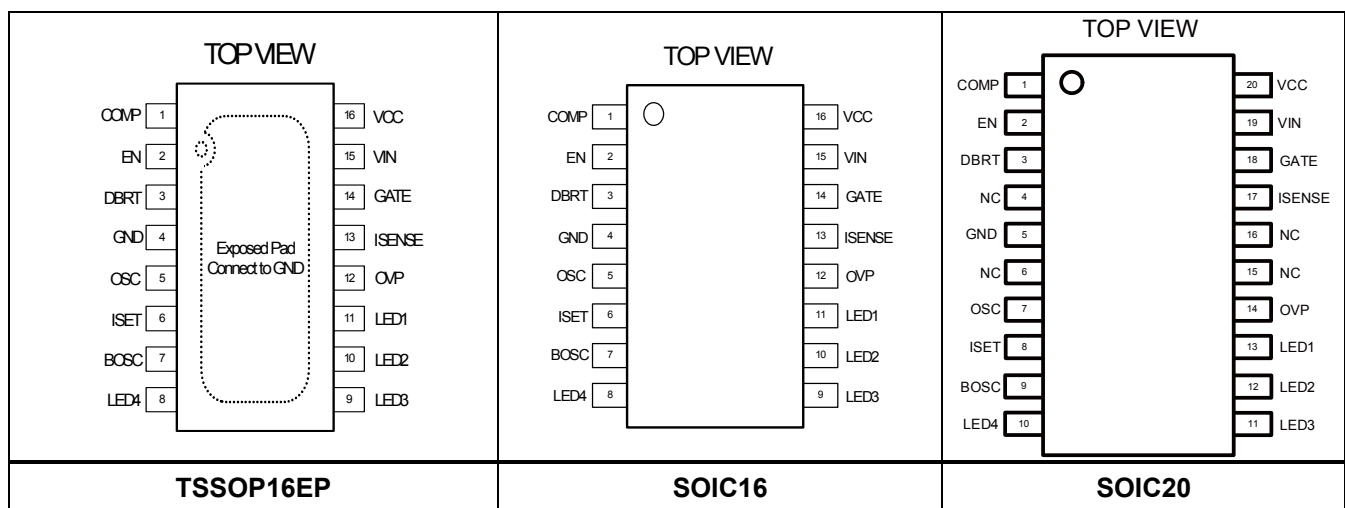

### ABSOLUTE MAXIMUM RATINGS <sup>(1)</sup>

|  |                |
|--|----------------|
| VIN                                    | -0.3V to +30V  |
| V <sub>GATE</sub>                      | -0.5V to +6.8V |
| VCC                                    | -0.5V to +6.8V |
| V <sub>LED1</sub> to V <sub>LED4</sub> | -1V to +55V    |
| All Other Pins                         | -0.3V to +6.3V |

### Continuous Power Dissipation (T<sub>A</sub> = 25°C) <sup>(2)</sup>

|                      |                  |
|----------------------|------------------|
| TSSOP16EP            | 2.78 W           |
| SOIC16               | 1.56 W           |
| SOIC20               | 1.74W            |
| Junction Temperature | 150°C            |
| Lead Temperature     | 260°C            |
| Storage Temperature  | -65 °C to +150°C |

### Recommended Operating Conditions <sup>(3)</sup>

|  |                 |
|--|-----------------|
| Supply Voltage VIN                         | 5V to 28V       |
| LED Current (Backlight)                    | 10mA to 180mA   |
| Operating Junction Temp. (T <sub>J</sub> ) | -40°C to +125°C |

### Thermal Resistance <sup>(4)</sup> θ<sub>JA</sub> θ<sub>JC</sub>

|           |    |             |
|-----------|----|-------------|
| TSSOP16EP | 45 | 10 ... °C/W |
| SOIC16    | 80 | 35 ... °C/W |
| SOIC20    | 72 | 30 ... °C/W |

#### Notes:

- Exceeding these ratings may damage the device.
- The maximum allowable power dissipation is a function of the maximum junction temperature T<sub>J</sub> (MAX), the junction-to-ambient thermal resistance θ<sub>JA</sub>, and the ambient temperature T<sub>A</sub>. The maximum allowable continuous power dissipation at any ambient temperature is calculated by P<sub>D</sub> (MAX) = (T<sub>J</sub> (MAX)-T<sub>A</sub>)/θ<sub>JA</sub>. Exceeding the maximum allowable power dissipation will cause excessive die temperature, and the regulator will go into thermal shutdown. Internal thermal shutdown circuitry protects the device from permanent damage.
- The device is not guaranteed to function outside of its operation conditions.
- Measured on JESD51-7, 4-layer PCB.

## ELECTRICAL CHARACTERISTICS

$V_{IN} = 12V$ ,  $V_{EN} = 5V$ ,  $T_A = 25^\circ C$ , unless otherwise noted.

| Parameters                       | Symbol           | Condition  | Min  | Typ  | Max  | Units     |
|----------------------------------|------------------|--|------|------|------|-----------|
| Operating Input Voltage          | $V_{IN}$         |  | 5    |      | 28   | V         |
| Supply Current (Quiescent)       | $I_Q$            | $V_{IN}=12V$ , $V_{EN}=5V$ , no load with switching      |      | 4    |      | mA        |
| Supply Current (Shutdown)        | $I_{ST}$         | $V_{EN}=0V$ , $V_{IN}=12V$                               |      |      | 2    | $\mu A$   |
| LDO Output Voltage               | $V_{CC}$         | $V_{EN}=5V$ , $7V < V_{IN} < 28V$ , $0 < I_{VCC} < 10mA$ | 5.2  | 5.8  | 6.4  | V         |
| Input UVLO Threshold             | $V_{IN\_UVLO}$   | Rising Edge  | 3.5  | 3.9  | 4.4  | V         |
| Input UVLO Hysteresis            |                  |  |      | 200  |      | mV        |
| EN High Voltage                  | $V_{EN\_HIGH}$   | $V_{EN}$ Rising  | 1.8  |      |      | V         |
| EN Low Voltage                   | $V_{EN\_LOW}$    | $V_{EN}$ Falling   |      |      | 0.6  | V         |
| <b>STEP-UP CONVERTER</b>         |                  |  |      |      |      |           |
| Gate Driver Impedance (Sourcing) |                  | $V_{CC}=6V$ , $V_{GATE}=6V$                              |      | 4    |      | $\Omega$  |
| Gate Driver Impedance (Sinking)  |                  | $V_{CC}=6V$ , $I_{GATE}=10mA$                            |      | 2    |      | $\Omega$  |
| Switching Frequency              | $f_{SW}$         | $R_{OSC} = 115k\Omega$                                   | 470  | 570  | 670  | kHz       |
|                                  |                  | $R_{OSC} = 374k\Omega$                                   | 140  | 175  | 210  | kHz       |
| OSC Voltage                      | $V_{OSC}$        |  | 1.17 | 1.22 | 1.26 | V         |
| Maximum Duty Cycle               | $D_{MAX}$        |  | 90   |      |      | %         |
| ISENSE Limit                     |                  | Max Duty Cycle   | 150  | 200  | 250  | mV        |
| COMP Source Current Limit        | $I_{COMP\_SOLI}$ |  |      | 65   |      | $\mu A$   |
| COMP Sink Current Limit          | $I_{COMP\_SILI}$ |  |      | 15   |      | $\mu A$   |
| COMP Trans-conductance           | $G_{COMP}$       | $\Delta I_{COMP} = \pm 10\mu A$                          |      | 400  |      | $\mu A/V$ |
| <b>PWM DIMMING</b>               |                  |  |      |      |      |           |
| DBRT Leakage Current             | $I_{DBRT\_LK}$   |  | -5   |      | 5    | $\mu A$   |
| BOSC Frequency                   | $f_{BOSC}$       | $C_{BOSC} = 2.2nF$                                       | 1.0  | 1.5  | 2    | kHz       |
| BOSC Output Current              | $I_{BOSC}$       |  | 6    | 7.5  | 9    | $\mu A$   |
| <b>LED CURRENT REGULATION</b>    |                  |  |      |      |      |           |
| ISET Voltage                     | $V_{ISET}$       |  | 1.17 | 1.22 | 1.26 | V         |
| LEDX Average Current             | $I_{LED}$        | $R_{ISET} = 30k\Omega$                                   | 31   | 32   | 33   | mA        |
| Current Matching <sup>(5)</sup>  |                  | $I_{LED} = 32mA$   |      |      | 2.5  | %         |

**ELECTRICAL CHARACTERISTICS** *(continued)*
 **$V_{IN} = 12V$ ,  $V_{EN} = 5V$ ,  $T_A = 25^{\circ}C$ , unless otherwise noted.**

| Parameters                             | Symbol         | Condition               | Min  | Typ  | Max  | Units       |
|--|----------------|-------------------------|------|------|------|-------------|
| LEDX Regulation Voltage                | $V_{LEDX}$     | $I_{LED}=60mA$          |      | 300  |      | mV          |
| <b>PROTECTION</b>                      |                |                         |      |      |      |             |
| OVP(Over Voltage Protection) Threshold | $V_{OVP\_OV}$  | Rising Edge             | 1.18 | 1.23 | 1.28 | V           |
| OVP UVLO threshold                     | $V_{OVP\_UV}$  | Step-up Converter Fails | 40   | 75   | 110  | mV          |
| LEDX UVLO Threshold                    | $V_{LEDX\_UV}$ |                         | 106  | 196  | 286  | mV          |
| LEDX Over Voltage Threshold            | $V_{LEDX\_OV}$ |                         | 5.6  | 6.1  | 6.6  | V           |
| Thermal Shutdown Threshold             | $T_{ST}$       |                         |      | 150  |      | $^{\circ}C$ |

**Notes:**

5) Matching is defined as the difference of the maximum to minimum current divided by 2 times average currents.

## TYPICAL PERFORMANCE CHARACTERISTICS

$V_{IN} = 12V$ , 10LEDs in series 4 strings, 120mA/string, unless otherwise noted.

**Efficiency vs.  $V_{IN}$**

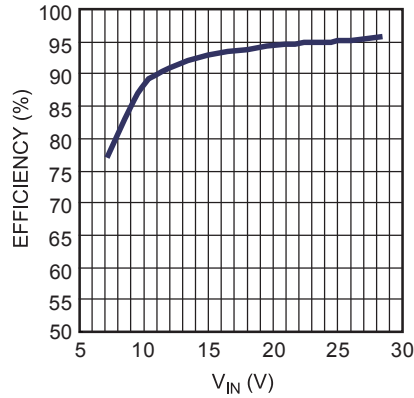

**Steady State**

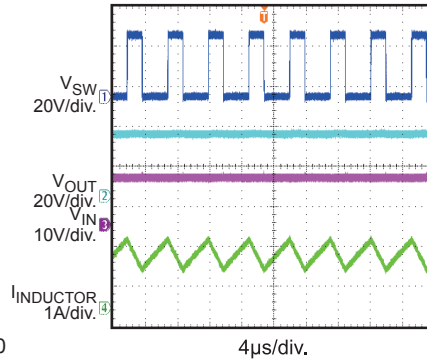

**$V_{IN}$  Power On**

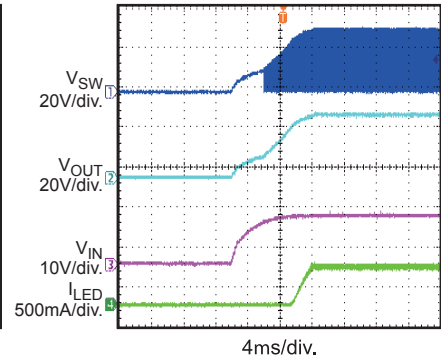

**EN Power On**

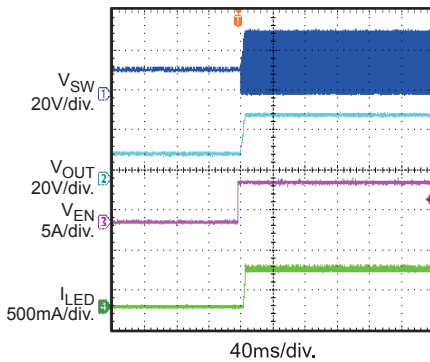

**DC Burst Dimming**

$V_{DIM} = 0.3V$ ,  $C_{BOSC} = 1.5nF$

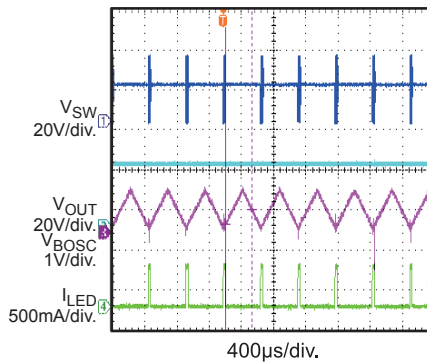

**External PWM Dimming**

$f_{PWM} = 200Hz$ ,  $D_{PWM} = 50\%$

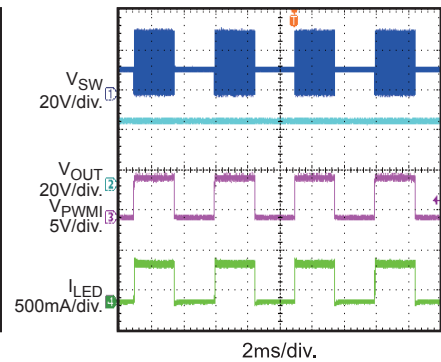

**Open LED Protection**

Open all LED string at working

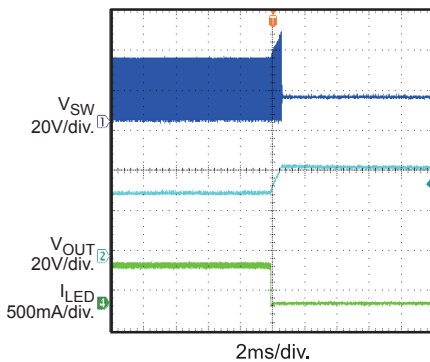

**Open LED Protection**

Open one LED string at working

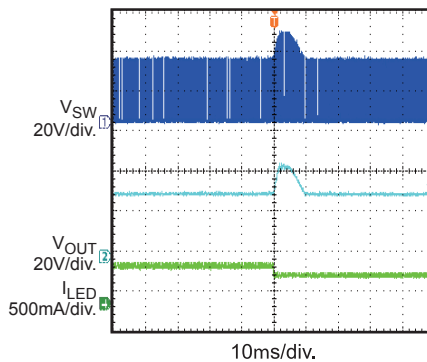

**Short LED Protection**

Short  $V_{OUT}$  to LEDx at working

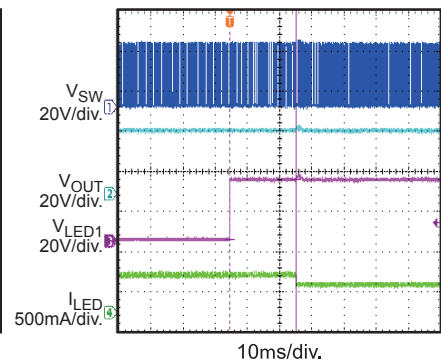

## PIN FUNCTIONS

| TSSOP16EP<br>&SOIC16<br>Pin # | SOIC20<br>Pin # | Name   | Description   |
|-------------------------------|-----------------|--------|---|
| 1                             | 1               | COMP   | Step-up Converter Compensation Pin. This pin compensates the regulation control loop. Connect a ceramic capacitor from COMP to GND.   |
| 2                             | 2               | EN     | Enable Control Input. A voltage greater than 1.8V will turn the part on and less than 0.6 V will turn the part off. Do not let this pin float.  |
| 3                             | 3               | DBRT   | Brightness Control Input. Apply a PWM signal on this pin for external PWM dimming mode. Apply a DC voltage range from 0.2V to 1.2V on this pin to linearly set the internal dimming duty cycle from 0% to 100% for DC-input PWM dimming mode. The MP3394S has positive dimming polarity on DBRT.  |
| 4                             | 5               | GND    | Ground.   |
| 5                             | 7               | OSC    | Switching Frequency Set. Connect a resistor between OSC and GND to set the step-up converter's switching frequency. The voltage at this pin is regulated to 1.22V. The clock frequency is proportional to the current sourced from this pin.  |
| 6                             | 8               | ISET   | LED Current Set. Tie a current-setting resistor from this pin to ground to program the current in each LED string. This pin voltage is regulated to 1.22V. The LED current is proportional to the current through the ISET resistor.  |
| 7                             | 9               | BOSC   | Dimming Repetition Set. This is the timing pin for the oscillator to set the dimming frequency. To use DC input PWM dimming mode, connect a capacitor from this pin to GND to set the internal dimming frequency. A saw-tooth waveform is generated on this pin. To use external PWM dimming mode, connect a resistor from this pin to GND, and apply the PWM signal on DBRT pin. |
| 8                             | 10              | LED4   | LED String 4 Current Input. This pin is the open-drain output of an internal dimming control switch. Connect the LED String 4 cathode to this pin.  |
| 9                             | 11              | LED3   | LED String 3 Current Input. This pin is the open-drain output of an internal dimming control switch. Connect the LED String 3 cathode to this pin.  |
| 10                            | 12              | LED2   | LED String 2 Current Input. This pin is the open-drain output of an internal dimming control switch. Connect the LED String 2 cathode to this pin.  |
| 11                            | 13              | LED1   | LED String 1 Current Input. This pin is the open-drain output of an internal dimming control switch. Connect the LED String 1 cathode to this pin.  |
| 12                            | 14              | OVP    | Over-Voltage Protection Input. Connect a resistor divider from output to this pin to program the OVP threshold. When this pin voltage reaches 1.23V, the MP3394S triggers Over Voltage Protection mode.   |
| 13                            | 17              | ISENSE | Current Sense Input. During normal operation, this pin senses the voltage across the external-inductor current-sensing resistor ( $R_{SENSE}$ ) for peak-current-mode control and also to limit the inductor current during every switching cycle. If this pin is not used for cascading applications, tie this pin to GND; do not let this pin float.                            |
| 14                            | 18              | GATE   | Step-up Converter Power Switch's Gate Driver Output. This pin drives the external power N-MOS device.   |

**PIN FUNCTIONS** *(continued)*

| TSSOP16EP<br>&SOIC16<br>Pin # | SOIC20<br>Pin # | Name | Description  |
|-------------------------------|-----------------|------|--|
| 15                            | 19              | VIN  | Supply Input. VIN supplies the power to the chip, as well as the step-up converter switch. Drive VIN with a 5V to 28V power source. Must be locally bypassed.                                    |
| 16                            | 20              | VCC  | The Internal 5.8V Linear Regulator Output. VCC provides power supply for the external- MOSFET switch-gate driver and the internal control circuitry. Bypass VCC to GND with a ceramic capacitor. |
|                               | 4, 6,<br>15, 16 | NC   | No Connect.  |

FUNCTIONAL BLOCK DIAGRAM

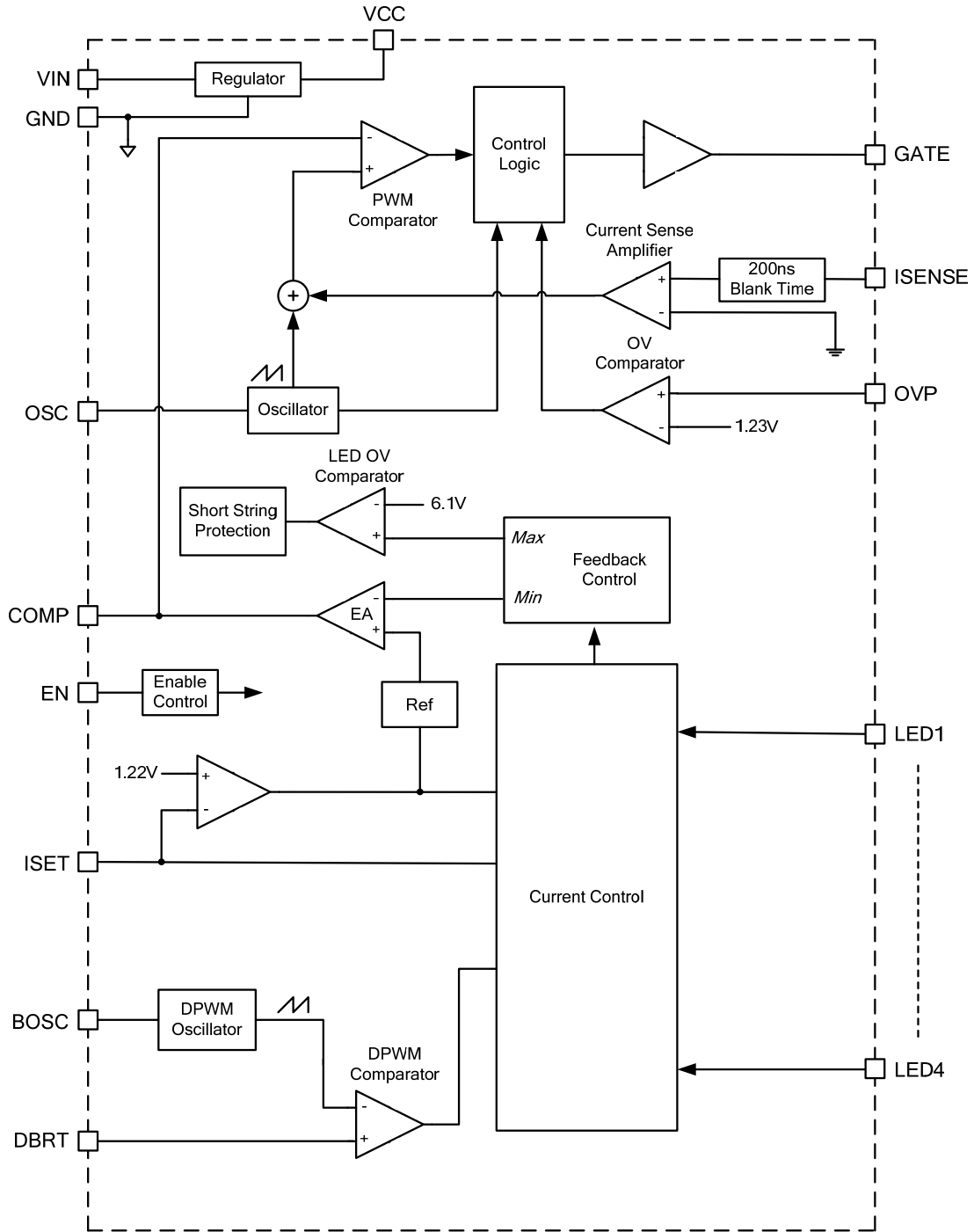

Figure 1—MP3394S Functional Block Diagram



## OPERATION

Employing the peak-current mode and a programmable constant frequency, the MP3394S is a step-up LED driver with 4 channels or regulated current sources to drive an array of up to 4 strings of white LEDs.

### Internal Regulator

The MP3394S includes an internal linear regulator (VCC). When VIN is greater than 6V, this regulator outputs a 5.8V power supply to the external MOSFET switch's gate driver and the internal control circuitry. The VCC voltage drops to 0V when the chip shuts down. The MP3394S features under-voltage lockout (UVLO). The chip is disabled until VCC exceeds the UVLO threshold. The UVLO hysteresis is approximately 200mV.

### System Startup

When enabled, the MP3394S checks the topology connection first. The chip monitors the over-voltage protection (OVP) pin to see if the Schottky diode is connected or if the boost output is shorted to GND. An OVP voltage of less than 75mV will disable the chip. The MP3394S also checks other safety limits, including UVLO and over-temperature protection (OTP) after passing the OVP test. If all the protection tests pass, the chip then starts boosting the step-up converter with an internal soft-start.

It is recommended that the enable signal is given after the establishment of the input voltage and PWM dimming signal during the start-up sequence.

### Step-Up Converter

The converter's operating frequency is programmable (from 100kHz to 500kHz) with an external set resistor on the OSC pin. This flexibility helps to optimize the size of external components and improve the efficiency.

At the beginning of each cycle, the internal clock output a signal to turn on the external MOSFET (minimum turn on time is 100ns). A stabilizing ramp added to the output of the current sense amplifier prevents sub-harmonic oscillations for duty cycles greater than 50 percent. This result is fed into the PWM comparator. When this resulting voltage reaches the output voltage of

the error amplifier ( $V_{COMP}$ ), the external MOSFET turns off.

The output voltage of the internal error amplifier is an amplified signal of the difference between the reference voltage and the feedback voltage. The converter automatically chooses the lowest active LEDX pin voltage to provide a high-enough bus voltage to power all the LED arrays.

If the feedback voltage drops below the reference, the output of the error amplifier increases. This result in more current flowing through the MOSFET, thus increasing the power delivered to the output. This forms a closed loop that regulates the output voltage.

Under light-load operation—where  $V_{OUT} \approx V_{IN}$ —, the converter runs in pulse-skipping mode where the MOSFET turns on for a minimum on-time of approximately 100ns, and then the converter discharges the power to the output for the remaining period. The external MOSFET remains off until the output voltage needs to be boosted again.

### Dimming Control

The MP3394S provides two PWM dimming methods: external PWM signal or DC-input PWM dimming mode (see Figure 2).

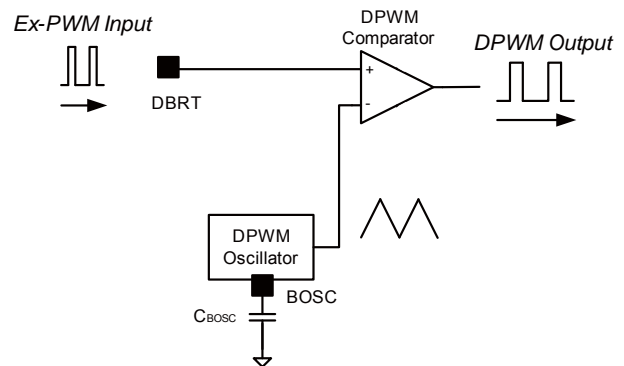

**Figure 2—PWM Dimming Method**

For external PWM dimming, ground the BOSC pin through a resistor, and apply an external PWM signal to the DBRT pin.

For DC-input PWM dimming, apply a DC analog signal to the DBRT pin, and connect a capacitor on BOSC pin to ground. The DC signal is then converted to a DPWM dimming signal with a proportional oscillation frequency.

The brightness of the LED array is proportional to the duty cycle of the DPWM signal. The DPWM signal frequency is set by the capacitor from the BOSC pin to ground.

### Open String Protection

Open string protection is achieved through the OVP pin and the LED (1 to 4) pins. If one or more strings are open, the respective LEDX pins are pulled to ground and the IC keeps charging the output voltage until it reaches the over-voltage protection (OVP) threshold. Then the chip marks off the strings which have an LEDX pin voltage lower than 196mV. Once marked, the remaining LED strings force the output voltage back into tight regulation. The string with the largest voltage drop determines the output regulation.

The MP3394S will always attempt to light at least one string. If all strings are open, the MP3394S shuts down the step-up converter. The strings will remain in this marked state until the chip reset.

### Short String Protection

The MP3394S monitors the LEDX pin voltages to determine if a short string fault has occurred. If one or more strings are shorted, the respective LEDX pins tolerate high voltage stress. If an LEDX pin voltage is higher than 6.1V, this condition triggers the detection of a short string. When a short string faults (LEDX over-voltage fault) keeps for 4096 switching clocks, the fault string is marked OFF and disabled. Once a string is marked OFF, it disconnects from the output voltage loop. The marked LED strings shut off completely until the part restarts. If all strings are shorted, the MP3394S will shut down the step-up converter. The strings remain marked OFF until the chip resets.

### Thermal Shut Down Protection

When MP3394S die temperature exceeds the thermal protection threshold, the thermal protection is triggered. IC shuts down until EN restart.

## APPLICATION INFORMATION

### Selecting the Switching Frequency

The switching frequency of the step-up converter is recommended from 100kHz to 500kHz for most of application. An oscillator resistor on OSC pin sets the internal oscillator frequency for the step-up converter according to the equation:

$$f_{sw}(\text{kHz}) = \frac{69190}{R_{osc}(\text{k}\Omega)}$$

For  $R_{osc}=374\text{k}\Omega$ , the switching frequency is set to 185 kHz.

### Setting the LED Current

The LED string currents are identical and set through the current setting resistor on the ISET pin. The ISET pin can not be open.

$$I_{LED}(\text{mA}) = \frac{800 \times 1.22\text{V}}{(R_{SET} + 0.5)\text{k}\Omega}$$

### Selecting the Input Capacitor

The input capacitor reduces the surge current drawn from the input supply and the switching noise from the device. The input capacitor impedance at the switching frequency should be less than the input source impedance to prevent the high-frequency switching current from passing through to the input. Use ceramic capacitors with X5R or X7R dielectrics for their low ESR and small temperature coefficients. For most applications, use a  $4.7\mu\text{F}$  ceramic capacitor in parallel with a  $220\mu\text{F}$  electrolytic capacitor.

### Selecting the Inductor and Current Sensing Resistor

The MP3394S requires an inductor to supply a higher output voltage while being driven by the input voltage. A larger value inductor results in less ripple current, resulting in lower peak inductor current and reducing stress on the internal N-channel MOSFET. However, the larger value inductor has a larger physical size, higher series resistance, and lower saturation current.

Choose an inductor that does not saturate under the worst-case load conditions. Select the minimum inductor value to ensure that the boost converter works in continuous conduction mode with high efficiency and good EMI performance. Calculate the required inductance value using the equation:

$$L \geq \frac{\eta \times V_{OUT} \times D \times (1-D)^2}{2 \times f_{sw} \times I_{LOAD}}$$

$$D = 1 - \frac{V_{IN}}{V_{OUT}}$$

Where  $V_{IN}$  and  $V_{OUT}$  are the input and output voltages,  $f_{sw}$  is the switching frequency,  $I_{LOAD}$  is the LED load current, and  $\eta$  is the efficiency.

The switching current is usually used for the peak current mode control. In order to avoid hitting the current limit, the voltage across the sensing resistor  $R_{SENSE}$  must measure less than 80% of the worst-case current-limit voltage,  $V_{SENSE}$ .

$$R_{SENSE} = \frac{0.8 \times V_{SENSE}}{I_{L(PEAK)}}$$

$$I_{L(PEAK)} = \frac{V_{OUT} \times I_{LOAD}}{\eta V_{IN}} + \frac{V_{IN} \times (V_{OUT} - V_{IN})}{2 \times L \times f_{sw} \times V_{OUT}}$$

Where  $I_{L(PEAK)}$  is the peak value of the inductor current.  $V_{SENSE}$  is shown in Figure 3.

**Vsense vs. Duty Cycle**

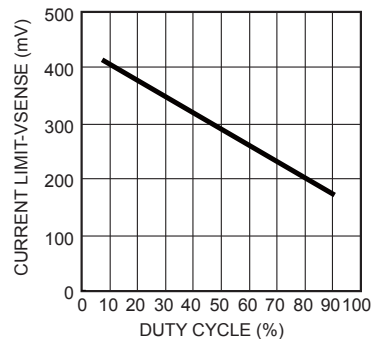

**Figure 3— $V_{SENSE}$  vs Duty Cycle**

### Selecting the Power MOSFET

The MP3394S is capable of driving a wide variety of N-channel power MOSFETS. The critical parameters of selection of a MOSFET are:

1. Maximum drain-to-source voltage,  $V_{DS(MAX)}$
2. Maximum current,  $I_{D(MAX)}$
3. On-resistance,  $R_{DS(ON)}$

4. Gate source charge  $Q_{GS}$  and gate drain charge  $Q_{GD}$
5. Total gate charge,  $Q_G$

Ideally, the off-state voltage across the MOSFET is equal to the output voltage. Considering the voltage spike when it turns off,  $V_{DS(MAX)}$  should be greater than 1.5 times of the output voltage.

The maximum current through the power MOSFET occurs at the maximum input voltage and the maximum output power. The maximum RMS current through the MOSFET is given by

$$I_{RMS(MAX)} = I_{IN(MAX)} \times \sqrt{D_{MAX}}, \text{ where:}$$

$$D_{MAX} \approx \frac{V_{OUT} - V_{IN(MIN)}}{V_{OUT}}$$

The current rating of the MOSFET should be greater than  $1.5 \times I_{RMS}$

The ON resistance of the MOSFET determines the conduction loss, which is given by:

$$P_{cond} = I_{RMS}^2 \times R_{DS(on)} \times k$$

Where  $k$  is the temperature coefficient of the MOSFET.

The switching loss is related to  $Q_{GD}$  and  $Q_{GS1}$  which determine the commutation time.  $Q_{GS1}$  is the charge between the threshold voltage and the plateau voltage when a driver charges the gate, which can be read in the chart of  $V_{GS}$  vs.  $Q_G$  of the MOSFET datasheet.  $Q_{GD}$  is the charge during the plateau voltage. These two parameters are needed to estimate the turn-on and turn-off losses.

$$P_{SW} = \frac{Q_{GS1} \times R_G}{V_{DR} - V_{TH}} \times V_{DS} \times I_{IN} \times f_{SW} + \frac{Q_{GD} \times R_G}{V_{DR} - V_{PLT}} \times V_{DS} \times I_{IN} \times f_{SW}$$

Where  $V_{TH}$  is the threshold voltage,  $V_{PLT}$  is the plateau voltage,  $R_G$  is the gate resistance, and  $V_{DS}$  is the drain-source voltage. Please note that calculating the switching loss is the most difficult part in the loss estimation. The formula above provides a simplified equation. For more accurate estimates, the equation becomes much more complex.

The total gate charge,  $Q_G$ , is used to calculate the gate drive loss. The expression is

$$P_{DR} = Q_G \times V_{DR} \times f_{SW}$$

Where  $V_{DR}$  is the drive voltage.

### Selecting the Output Capacitor

The output capacitor keeps the output voltage ripple small and ensures feedback loop stability. The output capacitor impedance must be low at the switching frequency. Ceramic capacitors with X7R dielectrics are recommended for their low ESR characteristics. For most applications, a 4.7 $\mu$ F ceramic capacitor in parallel with a 22 $\mu$ F electrolytic capacitor will suffice.

### Setting the Over Voltage Protection

The open string protection is achieved through the detection of the voltage on the OVP pin. In some cases, an LED string failure results in the feedback voltage always zero. The part then keeps boosting the output voltage higher and higher. If the output voltage reaches the programmed OVP threshold, the protection will be triggered.

To ensure the chip functions properly, select the resistor values for the OVP resistor divider to provide an appropriate set voltage. The recommended OVP point is about 1.1 to 1.2 times higher than the output voltage for normal operation.

$$V_{OVP} = 1.23 \times \left(1 + \frac{R_{HIGH}}{R_{LOW}}\right)$$

### Selecting Dimming Control Mode

The MP3394S provides two different dimming methods

#### 1. Direct PWM Dimming

An external PWM dimming signal is employed to achieve PWM dimming control. Connect a 100k $\Omega$  resistor from BOSC pin to GND and apply a PWM dimming signal—in the range of 100Hz to 20kHz—to the DBRT pin. The minimum recommended amplitude of the PWM signal is 1.2V. The low level should be less than 0.4V (See Figure 4).

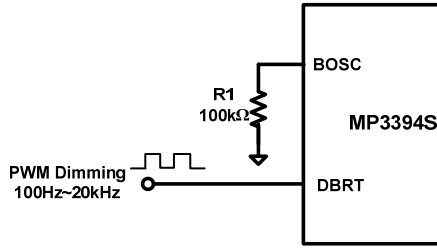

**Figure 4—Direct PWM Dimming**

Table 1 shows the PWM dimming duty Range with different PWM dimming frequency for most of applications.

**Table 1 The Range of PWM Dimming Duty**

| $f_{PWM}(Hz)$      | $D_{min}$ | $D_{max}$ |
|--------------------|-----------|-----------|
| $100 < f \leq 200$ | 0.30%     | 100%      |
| $200 < f \leq 500$ | 0.75%     | 100%      |
| $500 < f \leq 1k$  | 1.50%     | 100%      |
| $1k < f \leq 2k$   | 3.00%     | 100%      |
| $2k < f \leq 5k$   | 7.50%     | 100%      |
| $5k < f \leq 10k$  | 15.00%    | 100%      |
| $10k < f \leq 20k$ | 30.00%    | 100%      |

## 2. DC Input PWM Dimming

For DC input PWM dimming, apply an analog signal (ranging from 0.2 V to 1.2V) to the DBRT pin to modulate the LED current directly. If the DBRT voltage falls below 0.2V, the PWM duty cycle will be 0%. If the DBRT voltage goes above 1.2V, the output will be 100% (See Figure 5). The capacitor on BOSC pin sets the frequency of the internal triangle waveform according to the equation.

$$f_{BOSC} (kHz) = 3.5 / C_{BOSC}(nF)$$

Chose a dimming frequency in the range of 100Hz to 20kHz.

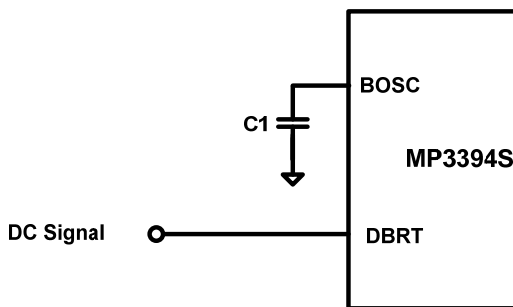
**Figure 5—DC input PWM Dimming**

## Expanding LED Channels

The MP3394S can expand the number of LED channels by using two or three MP3394Ss in parallel. To connect two MP3394Ss for a total of 8 LED strings, tie the VCC pins of the master IC and the slave IC together to power the slave IC's internal logic circuitry. Tie the COMP pins of the slave IC and the master IC together to regulate the voltage of all 8 strings LEDs. The slave IC MOSFET driving signals are not used; the boost converter can be only driven by the master IC. Do not leave the  $I_{SENSE}$  pin of the slave IC floating; tie it to ground. Apply the EN and DIM signals to both ICs. For best results, use external PWM dimming mode for synchronized and accurate dimming.

## Layout Considerations

The circuit layout for the MP3394S requires special attention to reduce EMI noise.

The loop from the external MOSFET (M1), through the output diode (D1) and the output capacitor (C2, C3) carry a high-frequency pulse current and must be as small and short as possible (See Figure 6).

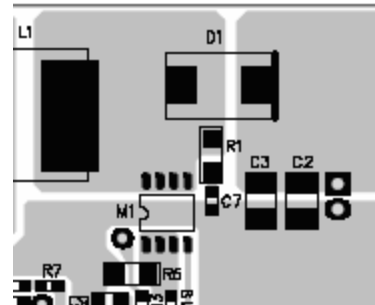
**Figure 6—Layout Consideration**

All logic signals refer to the signal ground. In order to reduce the noise affection, it is recommend to separate the power ground(PGND) and signal ground(GND), then connect PGND and GND together through single joint.

## External MOSFET for Short Protection

When output voltage is higher than rating of LED1-4 pins, external MOSFET is needed for each LED channel to avoid destroying LED1-4 pins. (See Figure 8)The rating of MOSFET must be higher than  $1.2 * V_{OUT} t$  and more than  $1.2 * I_{LED}$ .

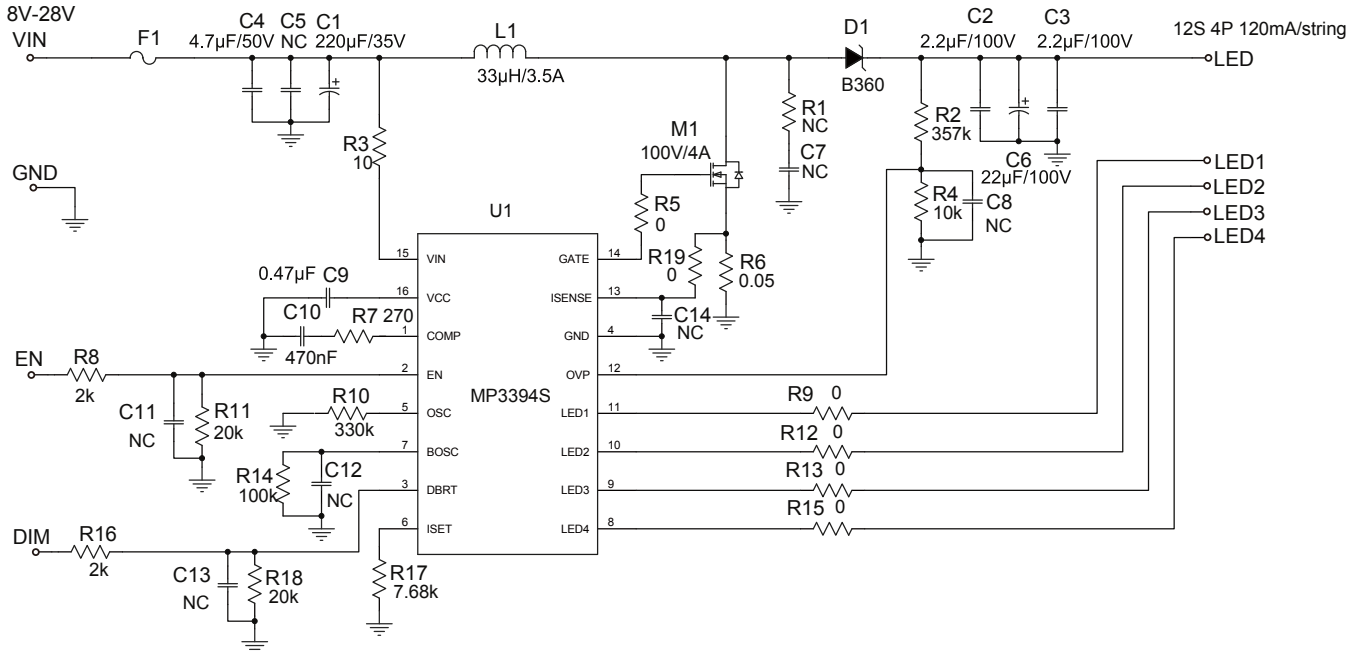
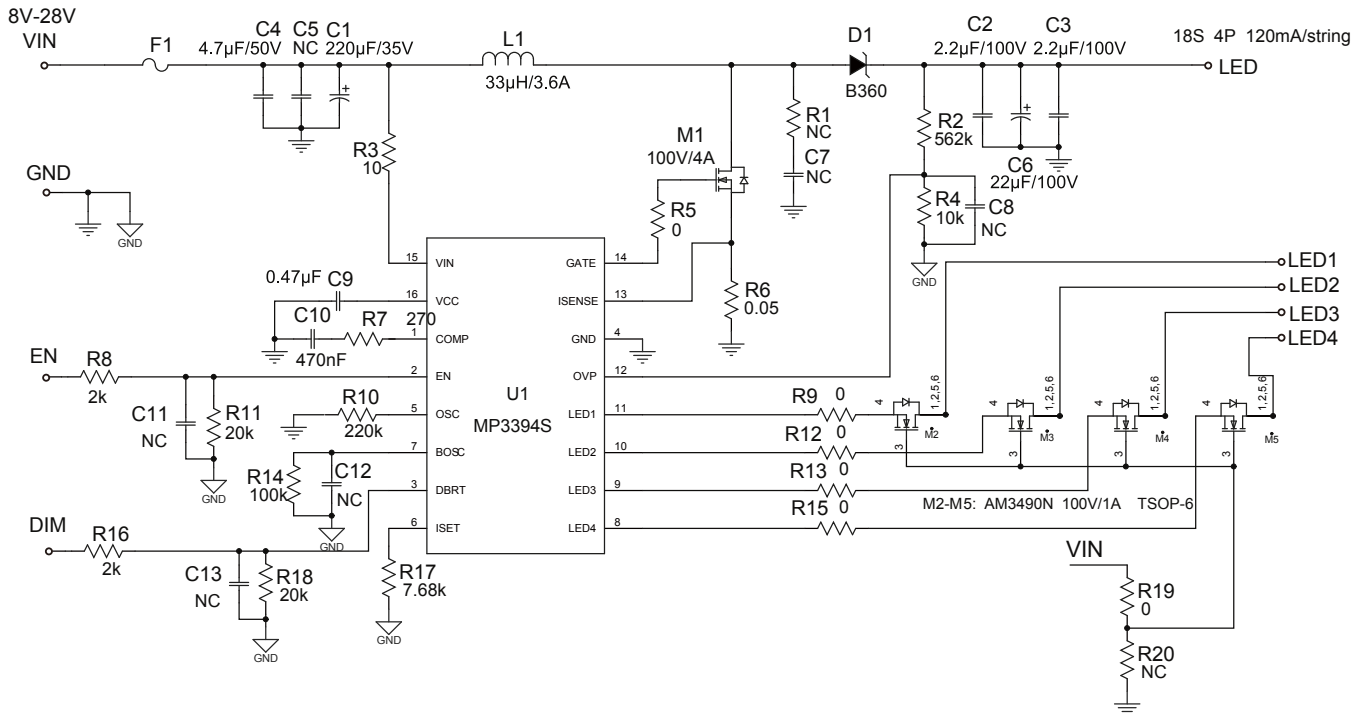
**TYPICAL APPLICATION CIRCUITS**

**Figure 1—Application Circuit**

**Figure 8 – Drive 18LEDs in Series, 4 strings 120mA/string**

**Note:** For  $V_{in} > 15V$  application, use R19 and R20(10k $\Omega$ ) divider to make a 15V bias voltage for M2-M5.

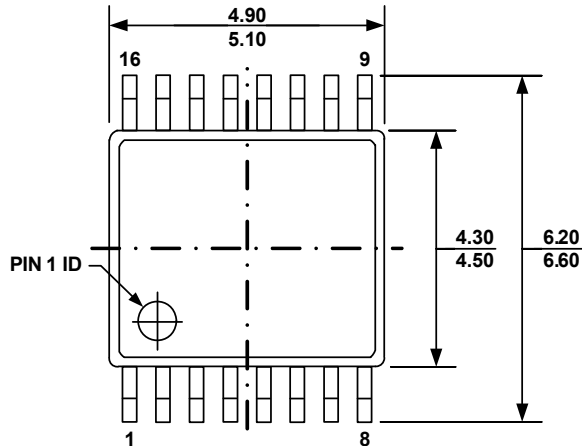

# PACKAGE INFORMATION

## TSSOP16 (with external thermal pad)



**TOP VIEW**

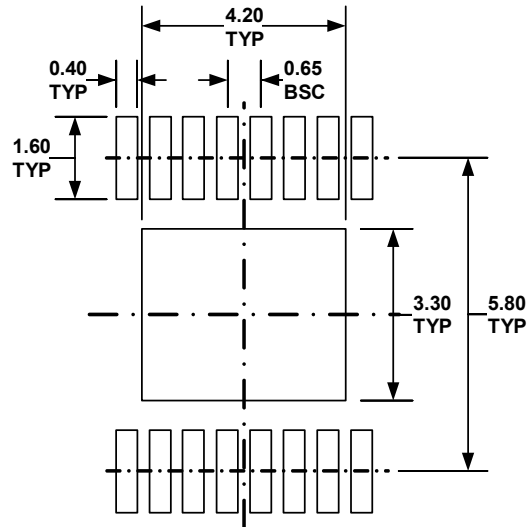

**RECOMMENDED LAND PATTERN**

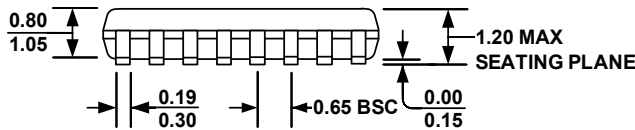

**FRONT VIEW**

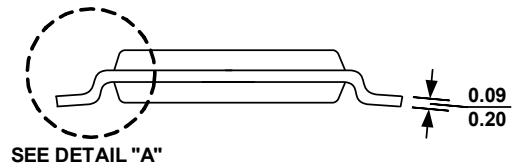

SEE DETAIL "A"

**SIDE VIEW**

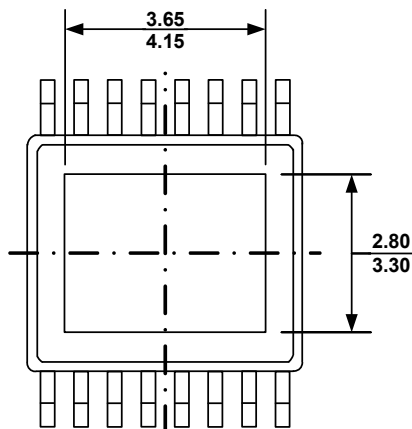

**BOTTOM VIEW**

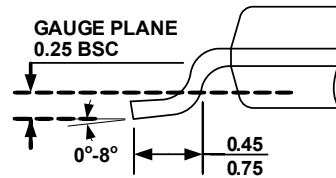

**DETAIL "A"**

**NOTE:**

- 1) ALL DIMENSIONS ARE IN MILLIMETERS
- 2) PACKAGE LENGTH DOES NOT INCLUDE MOLD FLASH, PROTRUSION OR GATE BURR
- 3) PACKAGE WIDTH DOES NOT INCLUDE INTERLEAD FLASH OR PROTRUSION.
- 4) LEAD COPLANARITY (BOTTOM OF LEADS AFTER FORMING) SHALL BE 0.10 MILLIMETERS MAX
- 5) DRAWING CONFORMS TO JEDEC MO-153, VARIATION ABT.
- 6) DRAWING IS NOT TO SCALE

**SOIC16**

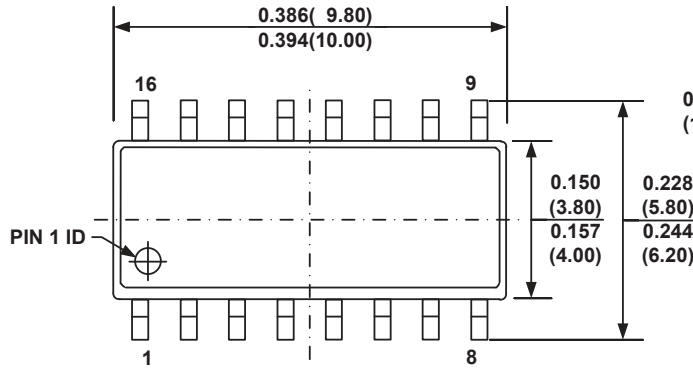

**TOP VIEW**

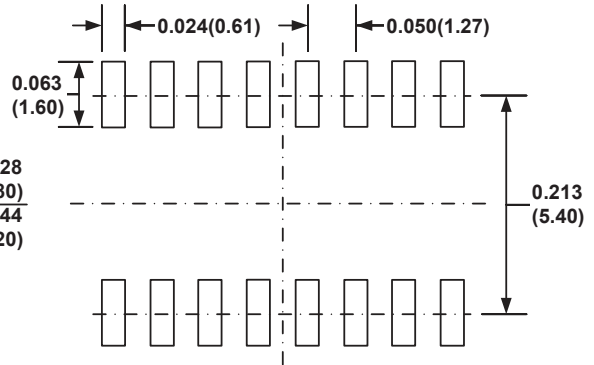

**RECOMMENDED LAND PATTERN**

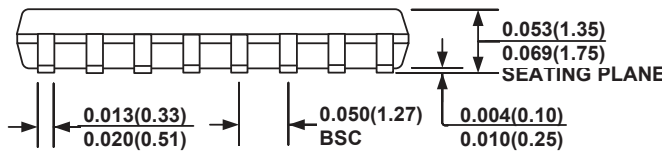

**FRONT VIEW**

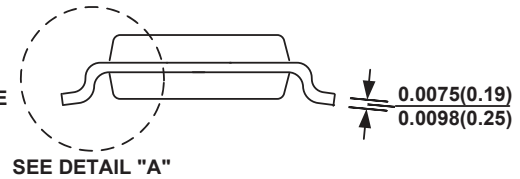

**SIDE VIEW**

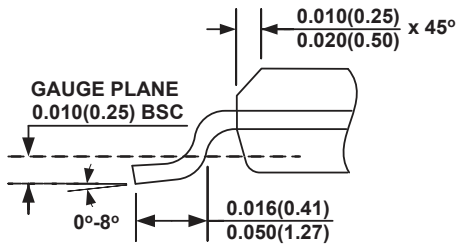

**DETAIL "A"**

**NOTE:**

- 1) CONTROL DIMENSION IS IN INCHES. DIMENSION IN BRACKET IS IN MILLIMETERS.
- 2) PACKAGE LENGTH DOES NOT INCLUDE MOLD FLASH, PROTRUSIONS OR GATE BURRS.
- 3) PACKAGE WIDTH DOES NOT INCLUDE INTERLEAD FLASH OR PROTRUSIONS.
- 4) LEAD COPLANARITY (BOTTOM OF LEADS AFTER FORMING) SHALL BE 0.004" INCHES MAX.
- 5) DRAWING CONFORMS TO JEDEC MS-012, VARIATION AC.
- 6) DRAWING IS NOT TO SCALE.

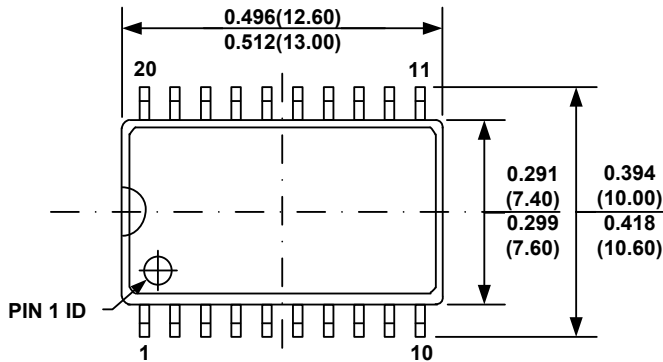
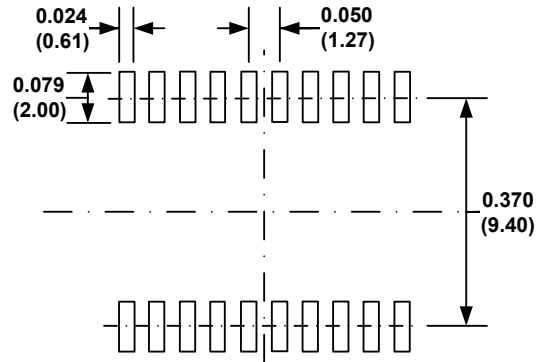
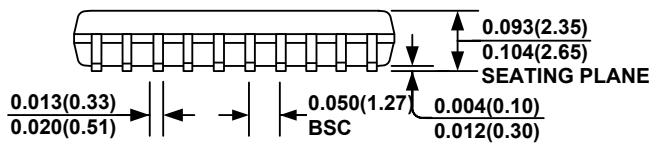
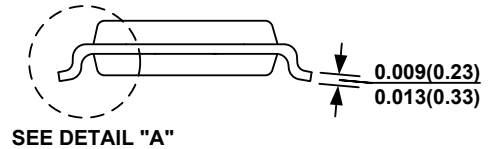
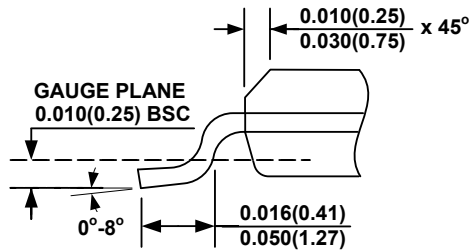

**SOIC20**

**TOP VIEW**

**RECOMMENDED LAND PATTERN**

**FRONT VIEW**

**SIDE VIEW**

**DETAIL "A"**
**NOTE:**

- 1) CONTROL DIMENSION IS IN INCHES. DIMENSION IN BRACKET IS IN MILLIMETERS.
- 2) PACKAGE LENGTH DOES NOT INCLUDE MOLD FLASH, PROTRUSIONS OR GATE BURRS.
- 3) PACKAGE WIDTH DOES NOT INCLUDE INTERLEAD FLASH OR PROTRUSIONS.
- 4) LEAD COPLANARITY (BOTTOM OF LEADS AFTER FORMING) SHALL BE 0.10 MILLIMETERS MAX.
- 5) DRAWING CONFORMS TO JEDEC MS-013, VARIATION AC.
- 6) DRAWING IS NOT TO SCALE.

**NOTICE:** The information in this document is subject to change without notice. Users should warrant and guarantee that third party Intellectual Property rights are not infringed upon when integrating MPS products into any application. MPS will not assume any legal responsibility for any said applications.



Компания «ЭлектроПласт» предлагает заключение долгосрочных отношений при поставках импортных электронных компонентов на взаимовыгодных условиях!

Наши преимущества:

- Оперативные поставки широкого спектра электронных компонентов отечественного и импортного производства напрямую от производителей и с крупнейших мировых складов;
- Поставка более 17-ти миллионов наименований электронных компонентов;
- Поставка сложных, дефицитных, либо снятых с производства позиций;
- Оперативные сроки поставки под заказ (от 5 рабочих дней);
- Экспресс доставка в любую точку России;
- Техническая поддержка проекта, помощь в подборе аналогов, поставка прототипов;
- Система менеджмента качества сертифицирована по Международному стандарту ISO 9001;
- Лицензия ФСБ на осуществление работ с использованием сведений, составляющих государственную тайну;
- Поставка специализированных компонентов (Xilinx, Altera, Analog Devices, Intersil, Interpoint, Microsemi, Aeroflex, Peregrine, Syfer, Eurofarad, Texas Instrument, Miteq, Cobham, E2V, MA-COM, Hittite, Mini-Circuits, General Dynamics и др.);

Помимо этого, одним из направлений компании «ЭлектроПласт» является направление «Источники питания». Мы предлагаем Вам помощь Конструкторского отдела:

- Подбор оптимального решения, техническое обоснование при выборе компонента;
- Подбор аналогов;
- Консультации по применению компонента;
- Поставка образцов и прототипов;
- Техническая поддержка проекта;
- Защита от снятия компонента с производства.



#### Как с нами связаться

**Телефон:** 8 (812) 309 58 32 (многоканальный)

**Факс:** 8 (812) 320-02-42

**Электронная почта:** [org@eplast1.ru](mailto:org@eplast1.ru)

**Адрес:** 198099, г. Санкт-Петербург, ул. Калинина, дом 2, корпус 4, литера А.