

## Mounting Dimensions (For Reference Only)

### AML11/12 and 21/22 SWITCHES AML41C/D and AML42C INDICATORS

Note: Top of full guard bezel housing  
.19/5,0 from panel.

#### PUSHBUTTONS

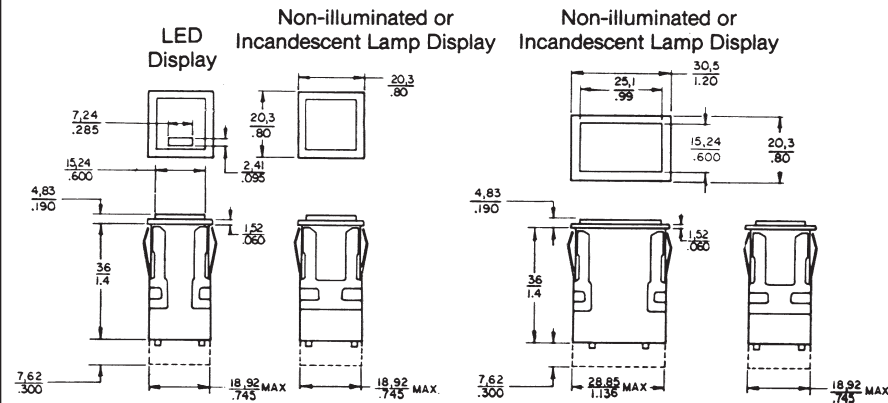

For terminal locations, see page 61.

### AML27 SWITCHES

#### KEYLOCK

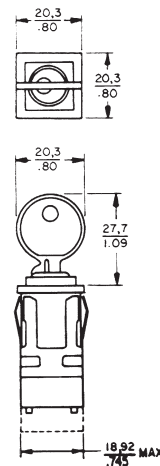

For terminal locations, see page 62.

### AML14/16 and AML24/26 SWITCHES

#### ROCKERS

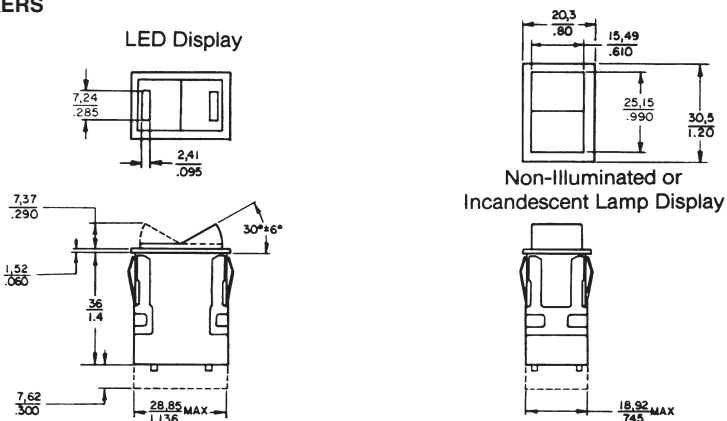

For terminal locations, see page 61, 62.

### AML13/15 and 23/25 SWITCHES

#### PADDLES

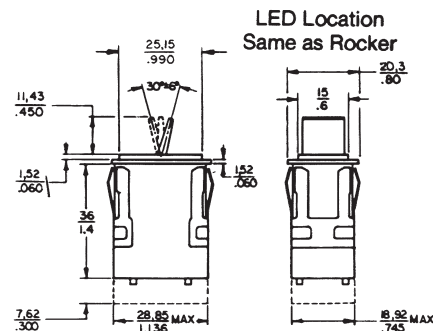

For terminal locations, see page 61, 62.

### AML41 INDICATOR

#### LENS STYLE

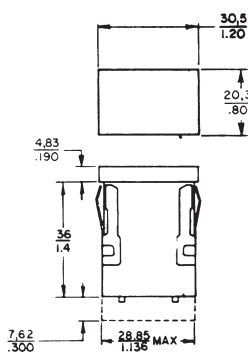

For terminal locations, see page 62.

### AML42 INDICATOR

#### MINIATURE

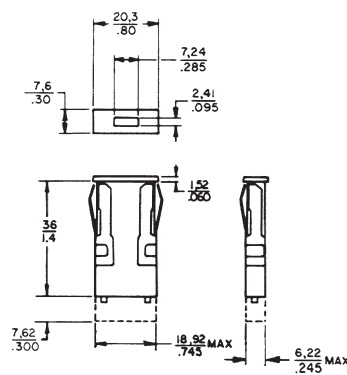

NOTE  
1 Dimensions are mm or mm/IN  
IN

### TERMINAL TYPES

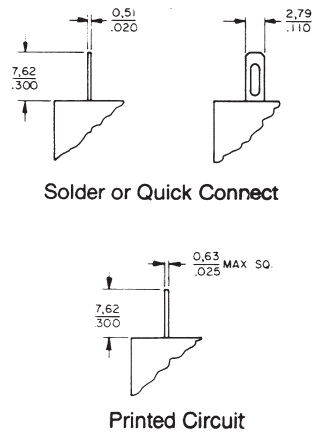

Solder Hole will accept two #22 AWG  
Stranded Conductor (per NEMA publication  
DC-2 1976)

Manuals

# Manual Switches

## Mounting Dimensions (For Reference Only)

AML Series

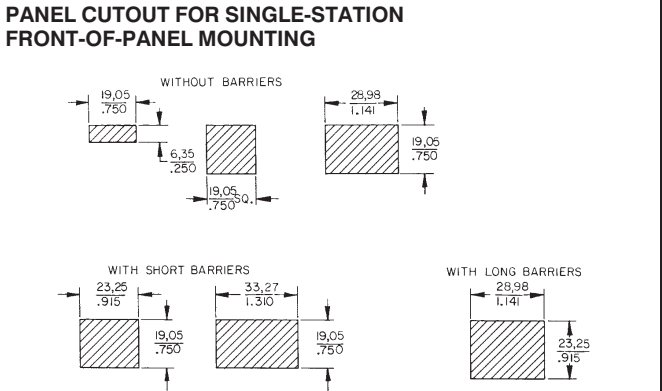
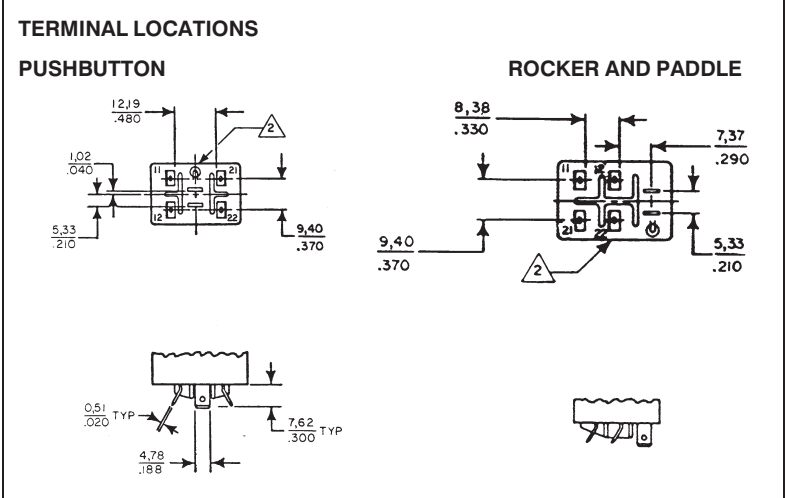
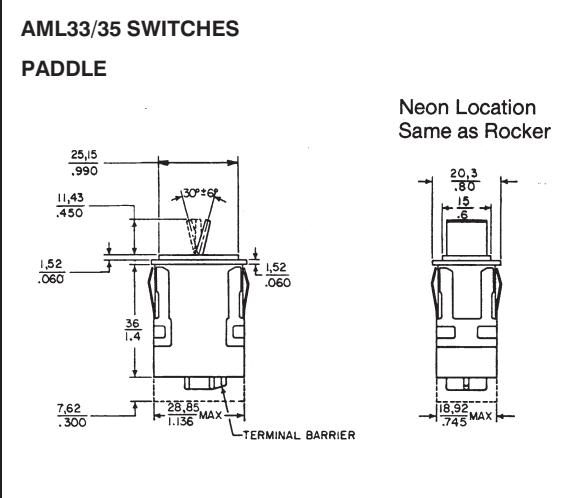
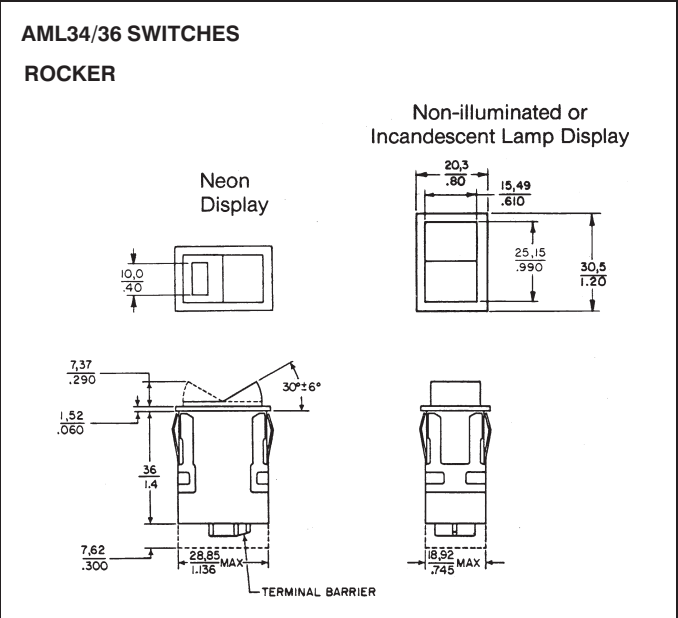
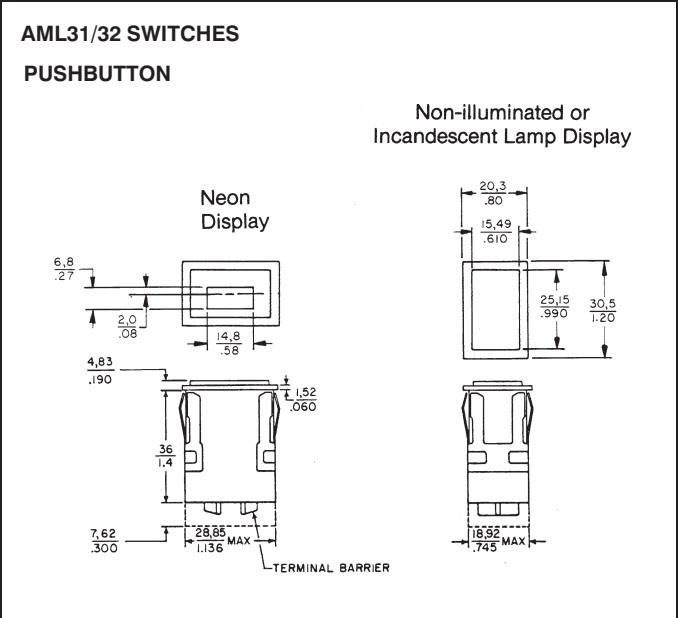

Recommended panel thickness: .060-.187/1,52-4,75

**NOTES**

1 Dimensions are mm or mm/IN

IN

Ⓜ Manufacturers logo on this side of housing

Solder Hole Will Accept One #14 AWG Stranded Conductor (Per NEMA Publication DC-2 1976)

**PANEL PUNCH FOR AML SERIES**

A panel punch is manufactured by Greenlee-Textron Tool Co., Rockford, IL (815-926-3011).

# Manual Switches

## Mounting Dimensions (For Reference Only)

### TERMINAL LOCATIONS FOR AML10 SWITCHES

#### PUSHBUTTONS

##### Solder and Quick-Connect

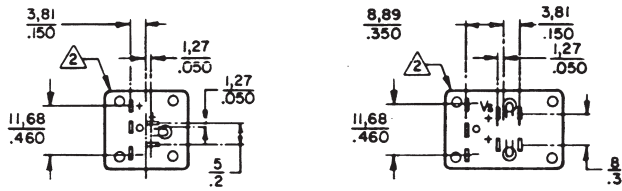

##### Printed Circuit

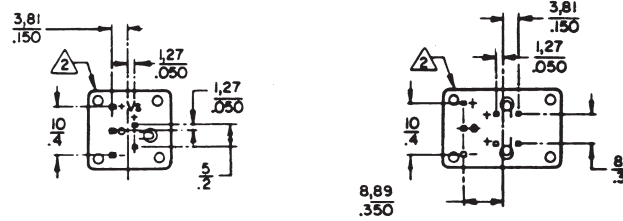

Illuminated devices shown (non-illuminated devices do not have lamp terminals).

#### ROCKERS AND PADDLES

##### Solder and Quick-Connect

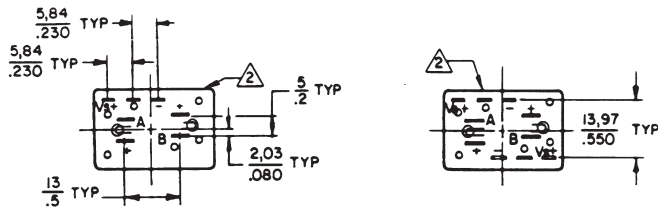

##### Printed Circuit

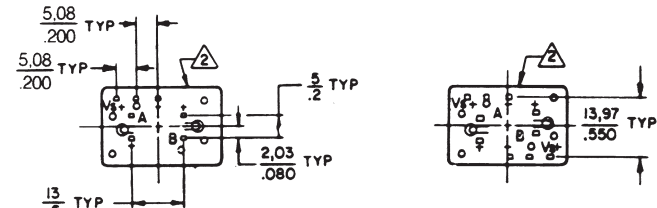

One Integrated Circuit

Two Integrated Circuits

One Integrated Circuit

Two Integrated Circuits

Illuminated devices shown (non-illuminated devices do not have lamp terminals)

### TERMINAL LOCATIONS FOR AML41 INDICATORS

#### Solder and Quick-Connect

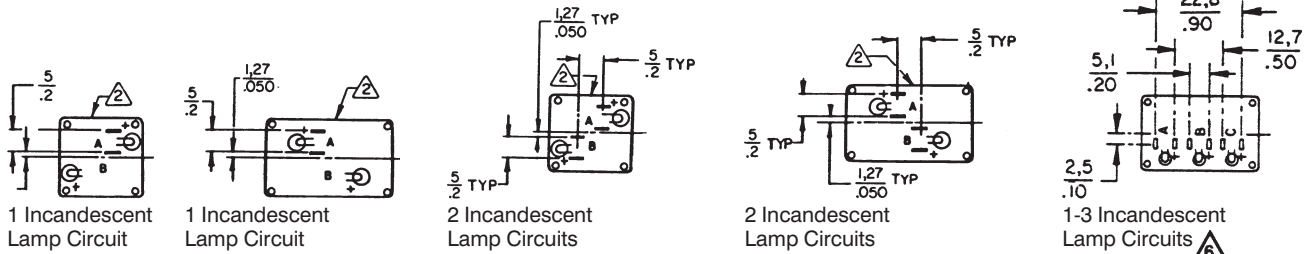

#### Printed Circuit

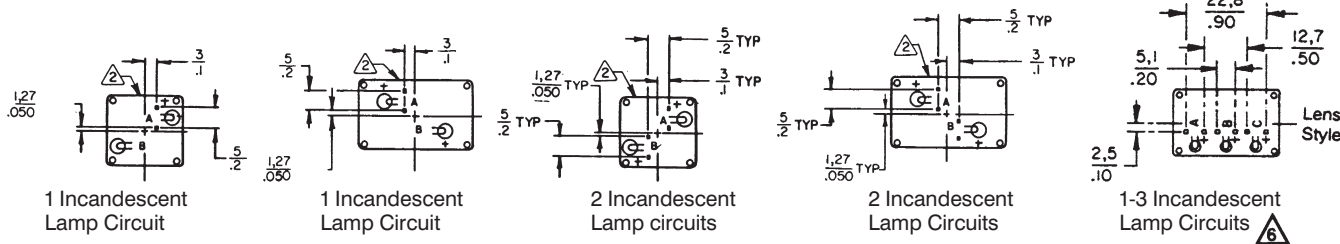

### TERMINAL LOCATIONS FOR AML42 INDICATORS

#### Solder and Quick-Connect

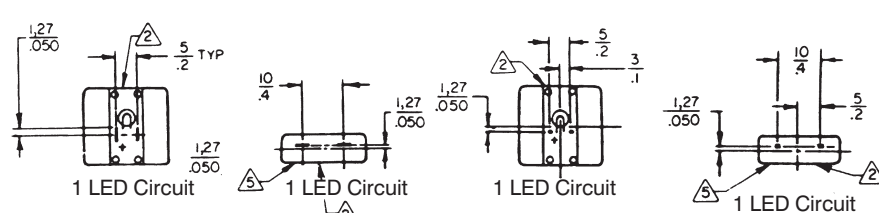

#### Printed Circuit

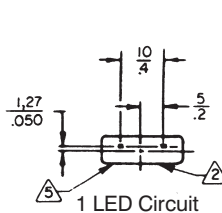

#### NOTE

- 1 Dimensions are MM or MM/IN
- 2 Manufacturer's logo on this side of housing
- 4 - Lamp terminals are not provided for non-illuminated devices
- 5 positive terminal ident. (+) marked this side of housing
- 6 1 - lamp termination identified by "B".  
2 - lamp termination identified by "A" and "C".

Manuals

# Manual Switches

## Mounting Dimensions (For Reference Only)

AML Series

### TERMINAL LOCATIONS FOR AML20 SWITCHES

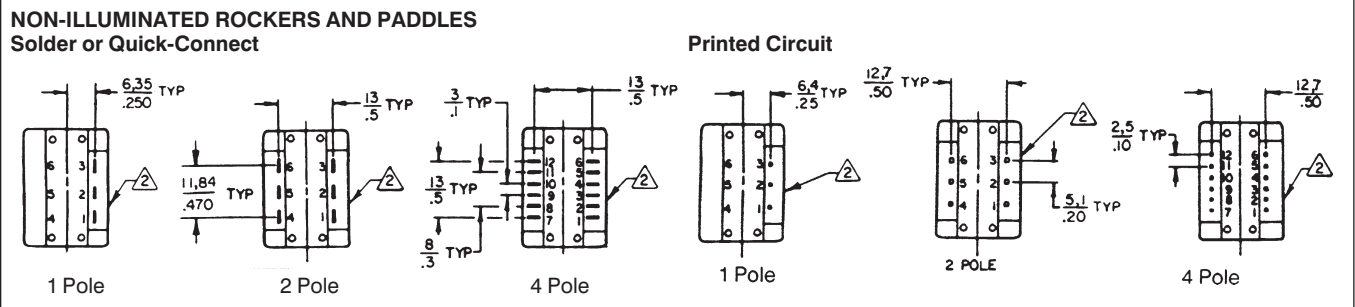
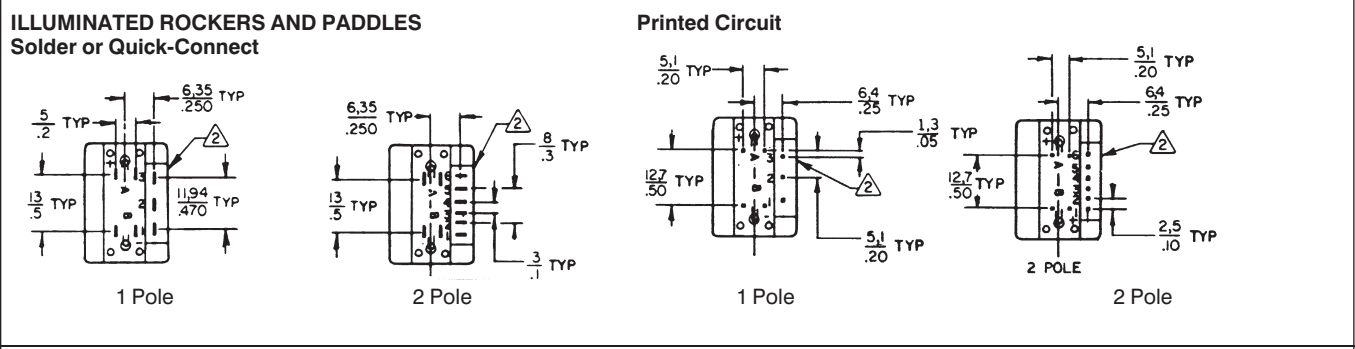
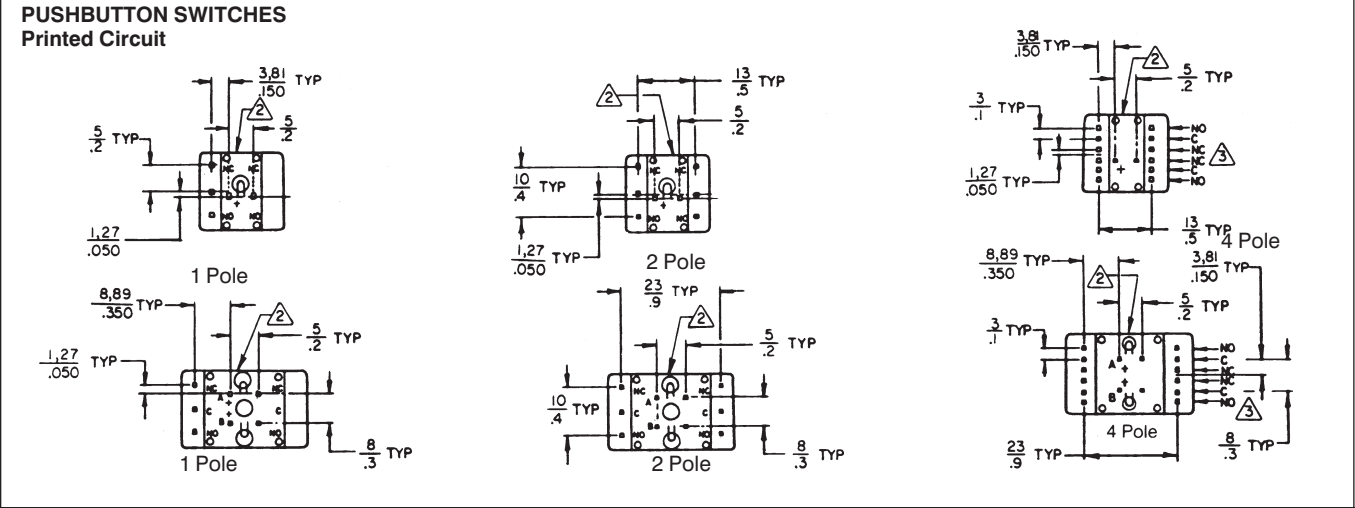
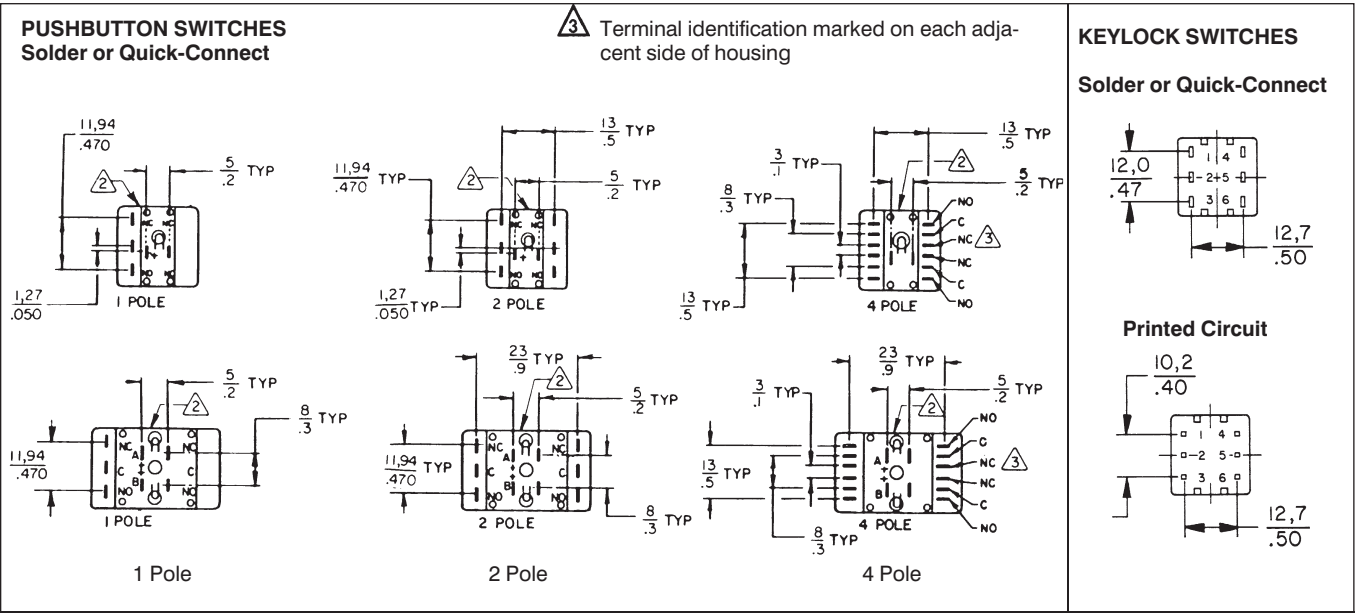

# Manual Switches

## Mounting Dimensions (For Reference Only)

AML Series

**ANNUNCIATORS**

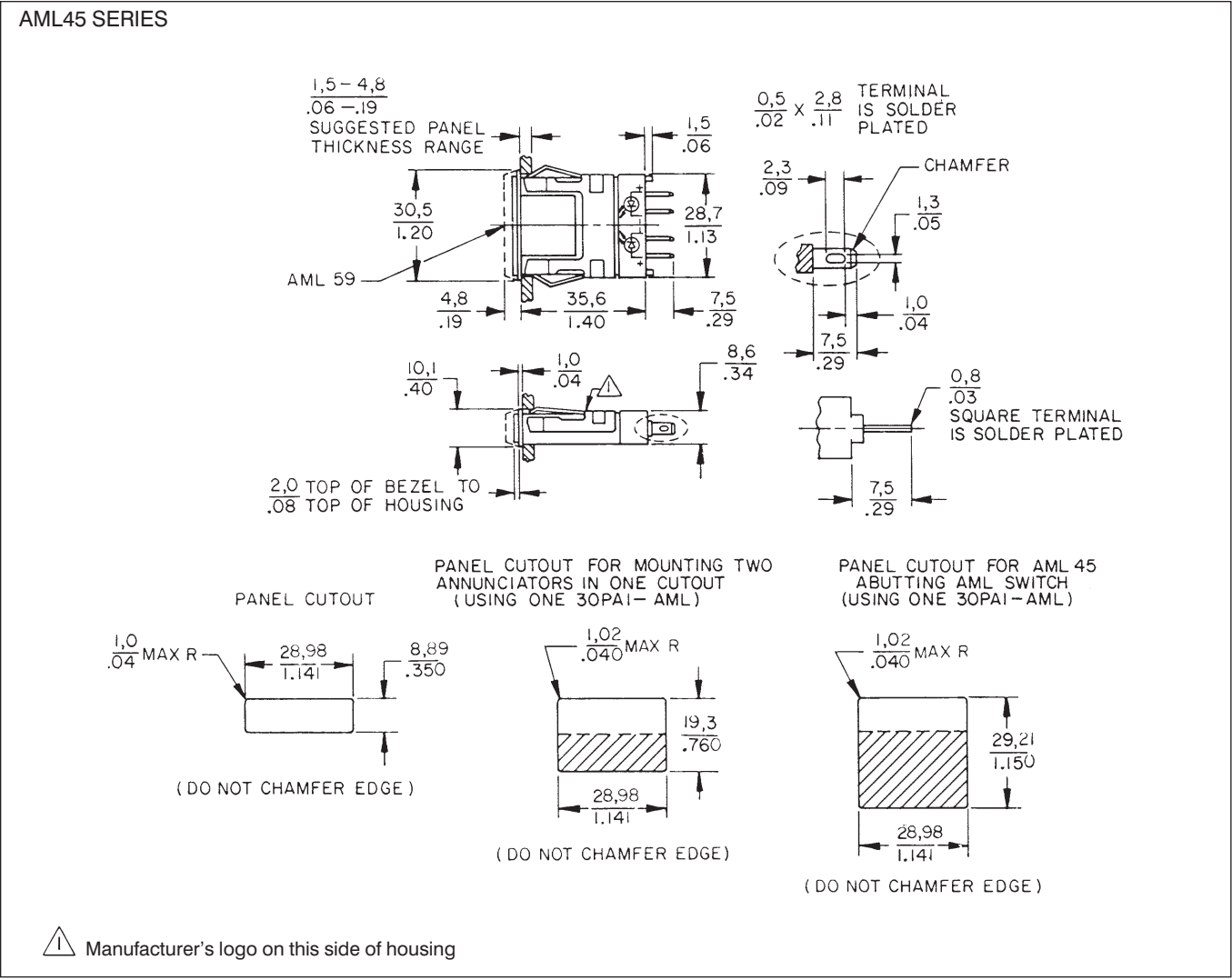

Manuals

For panel punch manufacturer, see page 60.

# Manual Switches

## Mounting Dimensions (For Reference Only)

### MULTI-STATION FRONT-PANEL MOUNTING

Panel cutouts (See page 61 for panel punch manufacturer.)

Square Switches & Indicators	Rect. Switches & Indicators	Annunciator
(.8) (No. of units) — .045*	(1.20) (No. of units) — .045*	(.40) (No. of units) — .045*
(20,3) (No. of units) — 1,14*	(30,5) (No. of units) — 1,14*	(10,1) (No. of units) — 1,14*

For each barrier, add .053/1,35

\* Note: If barriers are used, do not subtract .045 in./1,14 mm from the panel cutout formula. (.045 in./1,14mm is the allowance for the width of the bezel.)

### AML61 MULTI-STATION SUBPANEL MOUNTING

Panel cutouts for AML61

Mounting Bracket Orientation	Width	Length
A*	in. .810 mm 20,57	(.810)(No. of units)
B	in. .810 mm 20,57	(1.210)(No. of units)
C or D*	in. 1.210 mm 27,94	(.810)(No. of units)

\* More than two cans with mounting brackets required for strips of more than 10 units.

### AML61 MOUNTING CENTERS

Mounting Bracket Orientation		Mounting Centers/Number of Cans											
		1	2	3	4	5	6	7	8	9	10	11	12
"A" or "C"	in.	1.285	2.095	2.905	3.715	4.525	5.335	6.145	6.955	7.765	8.575	9.385	10.195
	mm	32,64	53,21	73,79	94,36	114,94	135,51	156,08	176,66	197,23	217,81	238,38	258,95
"B"	in.	1.685	2.895	4.105	5.315	6.525	7.735	8.945	10.155				
	mm	42,80	73,53	104,27	135,00	165,74	196,48	227,20	257,94				
"D" or "E"	in.	on C <sub>L</sub>	.807	1.614	2.421	3.228	4.035	4.842	5.649	6.456	7.263	8.070	8.877
	mm	on C <sub>L</sub>	20,50	41,00	61,49	81,99	102,49	122,99	143,48	163,98	184,48	204,98	225,48

Tolerance = ±.015

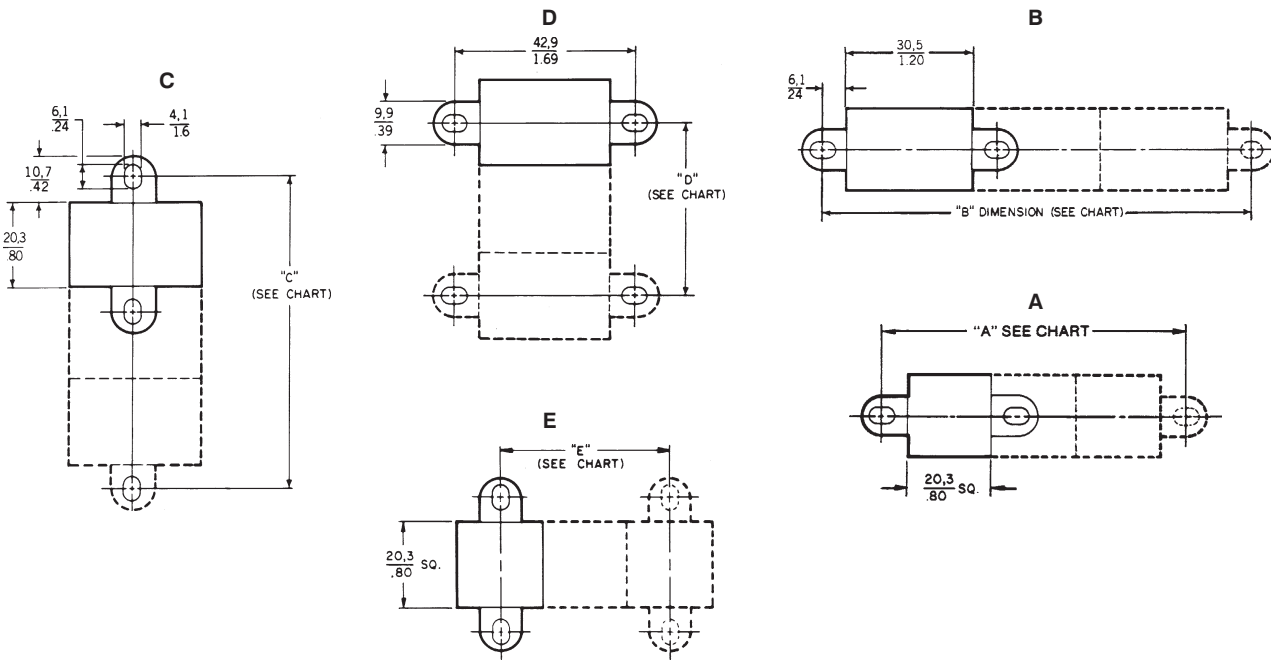

# Manual Switches

## Mounting Dimensions (For Reference Only)

### AML75 PANEL SEAL ACCESSORY

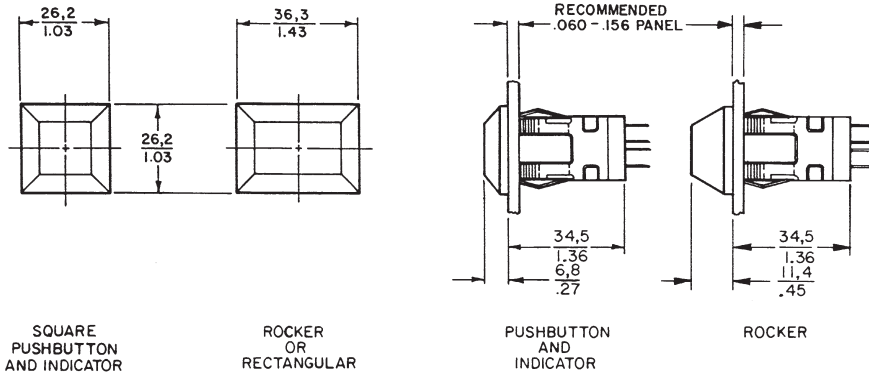

### Panel cutouts

Multiple panel sealed units should not be mounted together in a single elongated slot, since this would create an unsealed space between each unit.

Side-by-side mounting can be achieved, per the center-to-center dimensions shown in the drawing. (Dotted lines indicate the seal bases which are abutting at front of panel.)

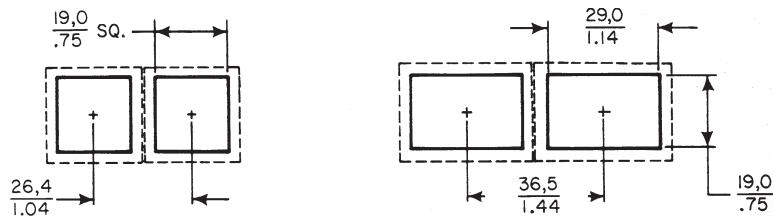

NOTE: Suggested cutout dimensions are based on an .125"/3,18 mm panel thickness. Individual preferences for inpanel fit

may require measurement of assemblies before panels are cut.

AML75 seals are not designed for use with the AML61 mounting system.

### AML76 SWITCH GUARD ACCESSORY

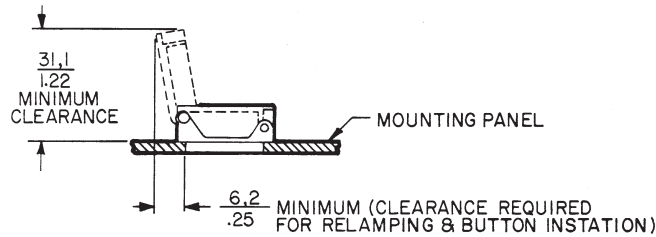
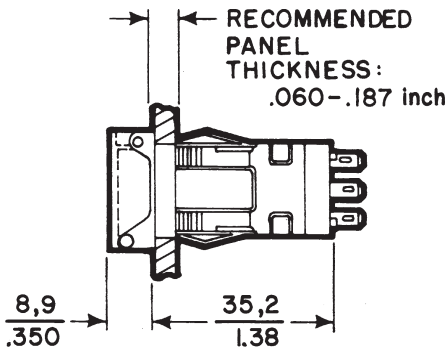

### PANEL CUTOUTS

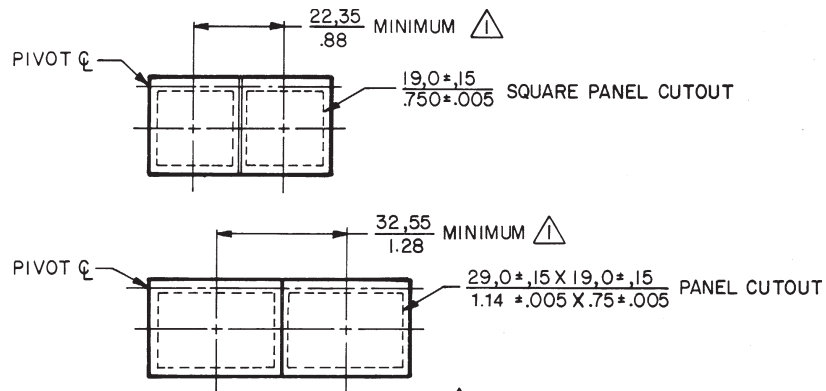

MINIMUM DIMENSION ALLOWED FOR MOUNTING GUARDS SIDE BY SIDE



Компания «ЭлектроПласт» предлагает заключение долгосрочных отношений при поставках импортных электронных компонентов на взаимовыгодных условиях!

Наши преимущества:

- Оперативные поставки широкого спектра электронных компонентов отечественного и импортного производства напрямую от производителей и с крупнейших мировых складов;
- Поставка более 17-ти миллионов наименований электронных компонентов;
- Поставка сложных, дефицитных, либо снятых с производства позиций;
- Оперативные сроки поставки под заказ (от 5 рабочих дней);
- Экспресс доставка в любую точку России;
- Техническая поддержка проекта, помощь в подборе аналогов, поставка прототипов;
- Система менеджмента качества сертифицирована по Международному стандарту ISO 9001;
- Лицензия ФСБ на осуществление работ с использованием сведений, составляющих государственную тайну;
- Поставка специализированных компонентов (Xilinx, Altera, Analog Devices, Intersil, Interpoint, Microsemi, Aeroflex, Peregrine, Syfer, Eurofarad, Texas Instrument, Miteq, Cobham, E2V, MA-COM, Hittite, Mini-Circuits, General Dynamics и др.);

Помимо этого, одним из направлений компании «ЭлектроПласт» является направление «Источники питания». Мы предлагаем Вам помощь Конструкторского отдела:

- Подбор оптимального решения, техническое обоснование при выборе компонента;
- Подбор аналогов;
- Консультации по применению компонента;
- Поставка образцов и прототипов;
- Техническая поддержка проекта;
- Защита от снятия компонента с производства.



#### Как с нами связаться

**Телефон:** 8 (812) 309 58 32 (многоканальный)

**Факс:** 8 (812) 320-02-42

**Электронная почта:** [org@eplast1.ru](mailto:org@eplast1.ru)

**Адрес:** 198099, г. Санкт-Петербург, ул. Калинина, дом 2, корпус 4, литера А.