

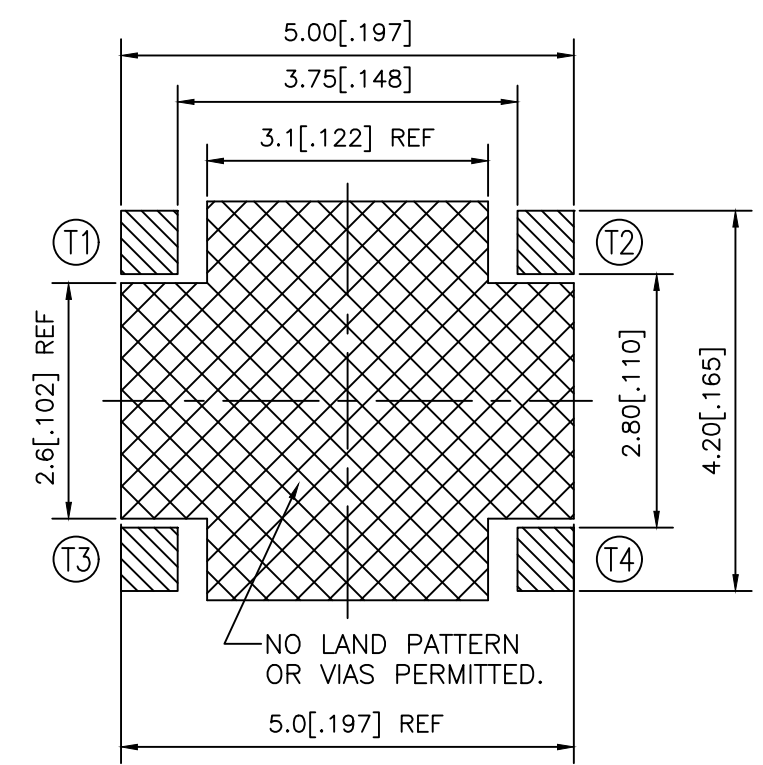

THIS DRAWING IS UNPUBLISHED. RELEASED FOR PUBLICATION
 © COPYRIGHT - TE Connectivity Ltd. ALL RIGHTS RESERVED.

REVISIONS					
P	LTR	DESCRIPTION	DATE	DWN	APVD
	B	REVISED PER ECR-19-004770	10APR2019	SR	DD

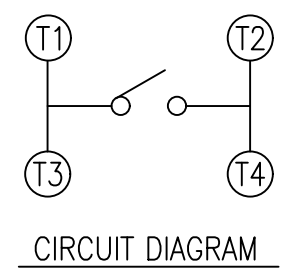
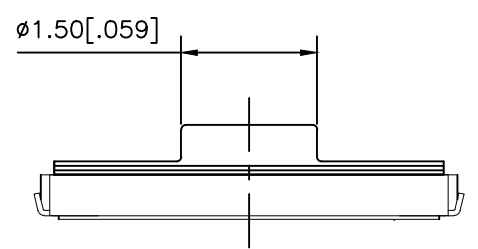
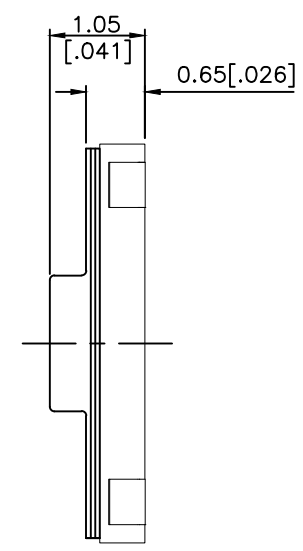
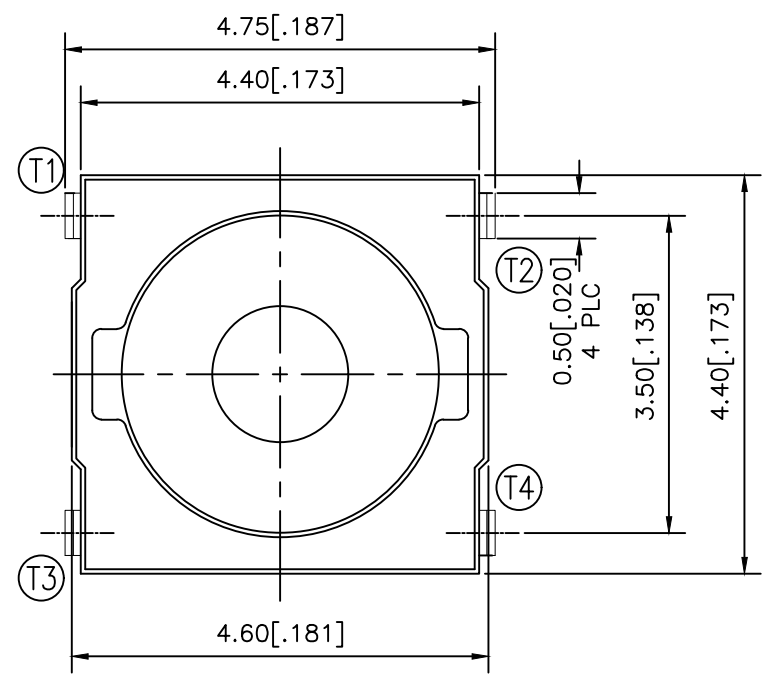

P.C.B. LAYOUT

260±50	MCSLPT4644B4PHTR	2337235-4
200±50	MCSLPT4644B3PHTR	2337235-3
160±50	MCSLPT4644B2PHTR	2337235-2
100±50	MCSLPT4644B1PHTR	2337235-1
ACTUATION FORCE (gf)	SMART PART NUMBER	PART NUMBER

THIS DRAWING IS A CONTROLLED DOCUMENT.		DWN	GANESH C M 04JUL2018		 TE Connectivity Ltd.											
DIMENSIONS: mm [INCHES]		CHK	ALEXANDER SHARPE 04JUL2018													
TOLERANCES UNLESS OTHERWISE SPECIFIED:		APVD	ALEXANDER SHARPE 04JUL2018													
<table border="1"> <tr><td>0 PLC</td><td>± -</td></tr> <tr><td>1 PLC</td><td>± -</td></tr> <tr><td>2 PLC</td><td>± 0.2 [.008]</td></tr> <tr><td>3 PLC</td><td>± -</td></tr> <tr><td>4 PLC</td><td>± -</td></tr> <tr><td>ANGLES</td><td>± -</td></tr> </table>		0 PLC	± -	1 PLC		± -	2 PLC	± 0.2 [.008]	3 PLC	± -	4 PLC	± -	ANGLES	± -	PRODUCT SPEC	-
0 PLC	± -															
1 PLC	± -															
2 PLC	± 0.2 [.008]															
3 PLC	± -															
4 PLC	± -															
ANGLES	± -															
MATERIAL		APPLICATION SPEC	-		NAME	SWITCH, TACTILE, LOW-PROFILE, MICRO-MINI, 4.6 x 4.4 x 1.05, J BEND										
FINISH		WEIGHT	-		SIZE	CAGE CODE	DRAWING NO	RESTRICTED TO								
-		-		A3		00779	C-2337235	-								
CUSTOMER DRAWING				SCALE	NTS	SHEET	1 OF 3	REV	B							

THIS DRAWING IS UNPUBLISHED.

RELEASED FOR PUBLICATION

© COPYRIGHT - TE Connectivity Ltd.

ALL RIGHTS RESERVED.

REVISIONS

P	LTR	DESCRIPTION	DATE	DWN	APVD
-	-	SEE SHEET 1	-	-	-

NOTES:

1. MATERIALS:

TERMINAL: COPPER ALLOY, SILVER FINISH
 BASE: THERMOPLASTIC, UL 94V-0, BLACK
 ACTUATOR: SILICONE RUBBER
 CONTACT: STAINLESS STEEL, SILVER FINISH

2. COMPLIANCE:

ALL MATERIALS AND FINISHES SHALL COMPLY WITH EU
 DIRECTIVE 2002/95/EC OF 27JAN2003(RoHS)

3. SPECIFICATIONS:

RATING: 50 mA, 12V DC
 CONTACT RESISTANCE: 100mΩ MAXIMUM (INITIAL)
 INSULATION RESISTANCE: 100MΩ MINIMUM (INITIAL)
 DIELECTRIC STRENGTH: 300V AC, 1 MINUTE
 OPERATING LIFE: 2337235-1 (100gf) = 1,000,000 CYCLES WITH LOAD
 2337235-2 (160gf) = 1,000,000 CYCLES WITH LOAD
 2337235-3 (200gf) = 500,000 CYCLES WITH LOAD
 2337235-4 (260gf) = 500,000 CYCLES WITH LOAD
 TRAVEL: 0.2±0.1 (.008±.004)
 ACTUATION FORCE: 2337235-1 = 100±50gf
 2337235-2 = 160±50gf
 2337235-3 = 200±50gf
 2337235-4 = 260±50gf
 OPERATING TEMPERATURE: -20° TO 70°C
 STORAGE TEMPERATURE: -30° TO 80°C

4. SOLDER CONDITIONS :

SMT:

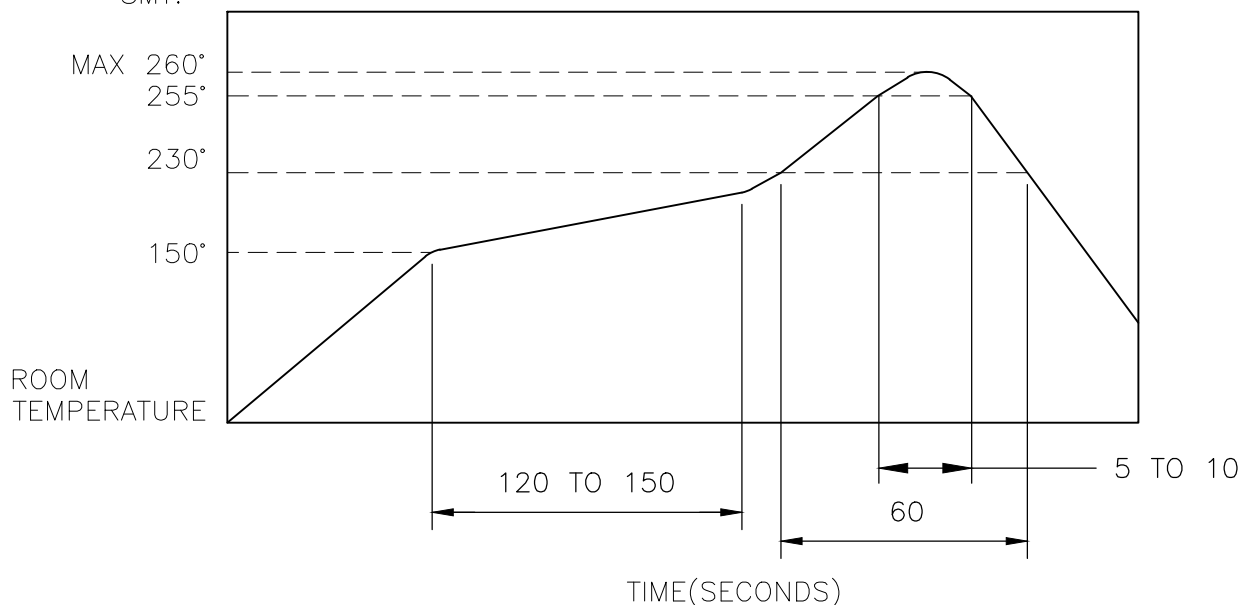

THE CONDITON NOTED ABOVE IS THE TEMPERATURE OF THE COPPER FOIL ON THE SURFACE OF THE PCB. THERE ARE CASES WHERE THE TEMPERATURE OF THE BOARD GREATLY DIFFERS FROM THE SURFACE OF THE SWITCH. DO NOT ALLOW THE SURFACE TEMPERATURE OF THE SWITCH TO EXCEED 260°C.

MANUAL SOLDERING:

SOLDERING TEMPERATURE	350°C MAXIMUM
CONTINUOUS SOLDERING TIME	5 SECONDS MAXIMUM

HANDLING PRECAUTIONS:

- CARE SHOULD BE EXERCISED SO THAT FLUX FROM THE TOP SURFACE OF THE PRINTED CIRCUIT BOARD DOES NOT ADHERE TO THE SWITCH.
 - DO NOT WASH THE SWITCH
5. OPERATING PRECAUTIONS:
- DO NOT ACTUATE THE SWITCH WITH EXCESSIVE FORCE
 - DISCONTINUE FORCE AFTER THE SWITCH HAS BEEN ACTUATED SO AS TO AVOID DEFORMATION OF THE COMPONENTS OF THE SWITCH. DEFORMATION OF THE COMPONENTS MAY CAUSE THE SWITCH TO MALFUNCTION.
 - ALIGN THE PLUNGER WITH THE SWITCH TO INSURE PROPER OPERATION

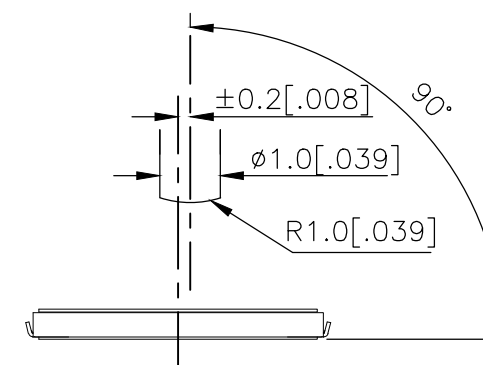

RECOMMENDED OPERATING CONDITIONS

THIS DRAWING IS A CONTROLLED DOCUMENT.		DWN	04JUL2018	TE Connectivity Ltd.													
		GANESH C M															
DIMENSIONS: mm [INCHES]		CHK	04JUL2018	NAME SWITCH, TACTILE, LOW-PROFILE, MICRO-MINI, 4.6 x 4.4 x 1.05, J BEND													
TOLERANCES UNLESS OTHERWISE SPECIFIED:		ALEXANDER SHARPE															
<table border="0"> <tr><td>0 PLC</td><td>± -</td></tr> <tr><td>1 PLC</td><td>± -</td></tr> <tr><td>2 PLC</td><td>± 0.2 [.008]</td></tr> <tr><td>3 PLC</td><td>± -</td></tr> <tr><td>4 PLC</td><td>± -</td></tr> <tr><td>ANGLES</td><td>± -</td></tr> </table>		0 PLC	± -	1 PLC	± -	2 PLC	± 0.2 [.008]	3 PLC	± -	4 PLC	± -	ANGLES	± -	APVD	04JUL2018	SIZE A3	
0 PLC	± -																
1 PLC	± -																
2 PLC	± 0.2 [.008]																
3 PLC	± -																
4 PLC	± -																
ANGLES	± -																
MATERIAL		ALEXANDER SHARPE		CAGE CODE 00779													
FINISH		PRODUCT SPEC				DRAWING NO C-2337235											
		APPLICATION SPEC		RESTRICTED TO -													
		WEIGHT				SCALE NTS											
		CUSTOMER DRAWING		SHEET 2 OF 3													
						REV B											

THIS DRAWING IS UNPUBLISHED. RELEASED FOR PUBLICATION
 © COPYRIGHT - TE Connectivity Ltd. ALL RIGHTS RESERVED.

REVISIONS					
P	LTR	DESCRIPTION	DATE	DWN	APVD
-	-	SEE SHEET 1	-	-	-

THE DIMENSIONS OF CARRIER TAPE AND REEL

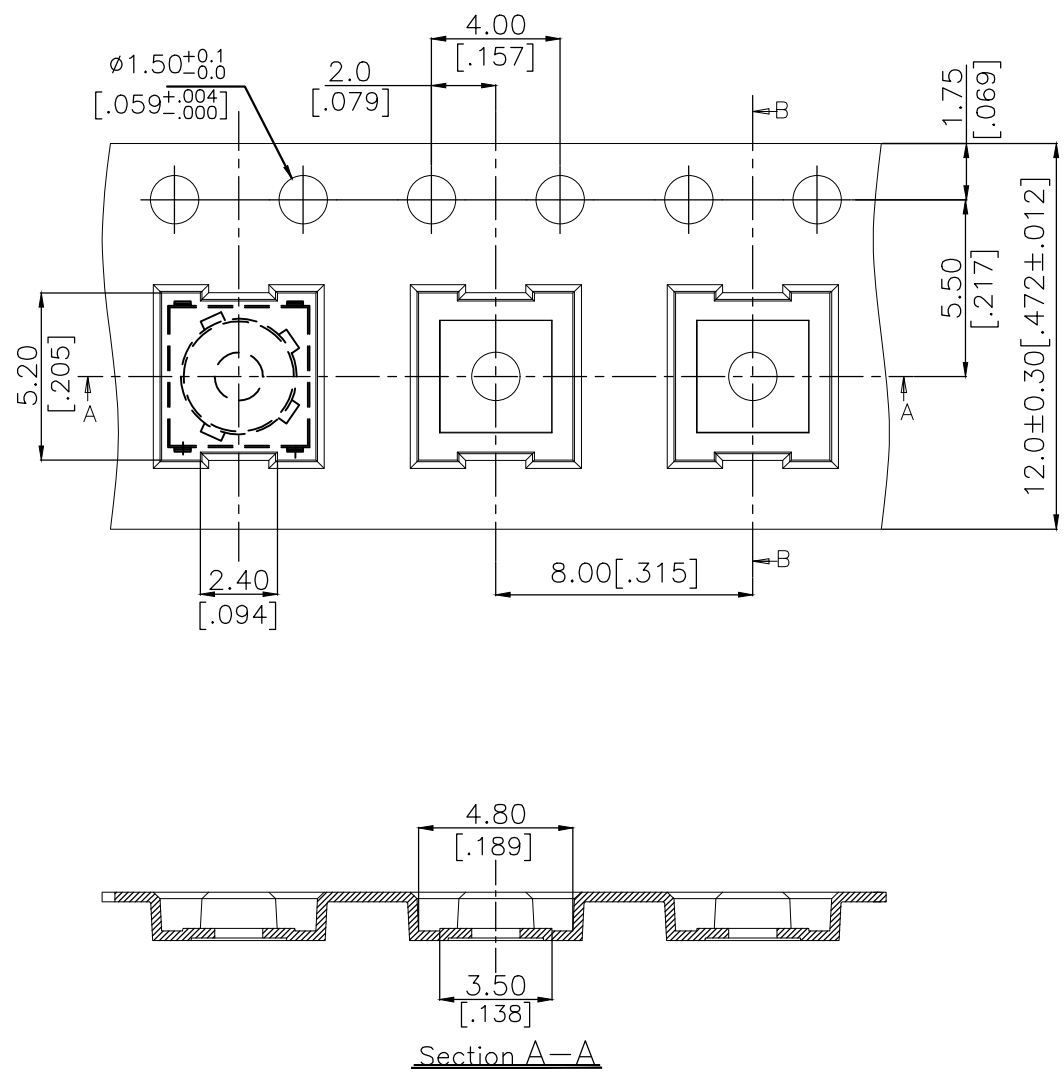

ORIENTATION OF PILOT HOLES

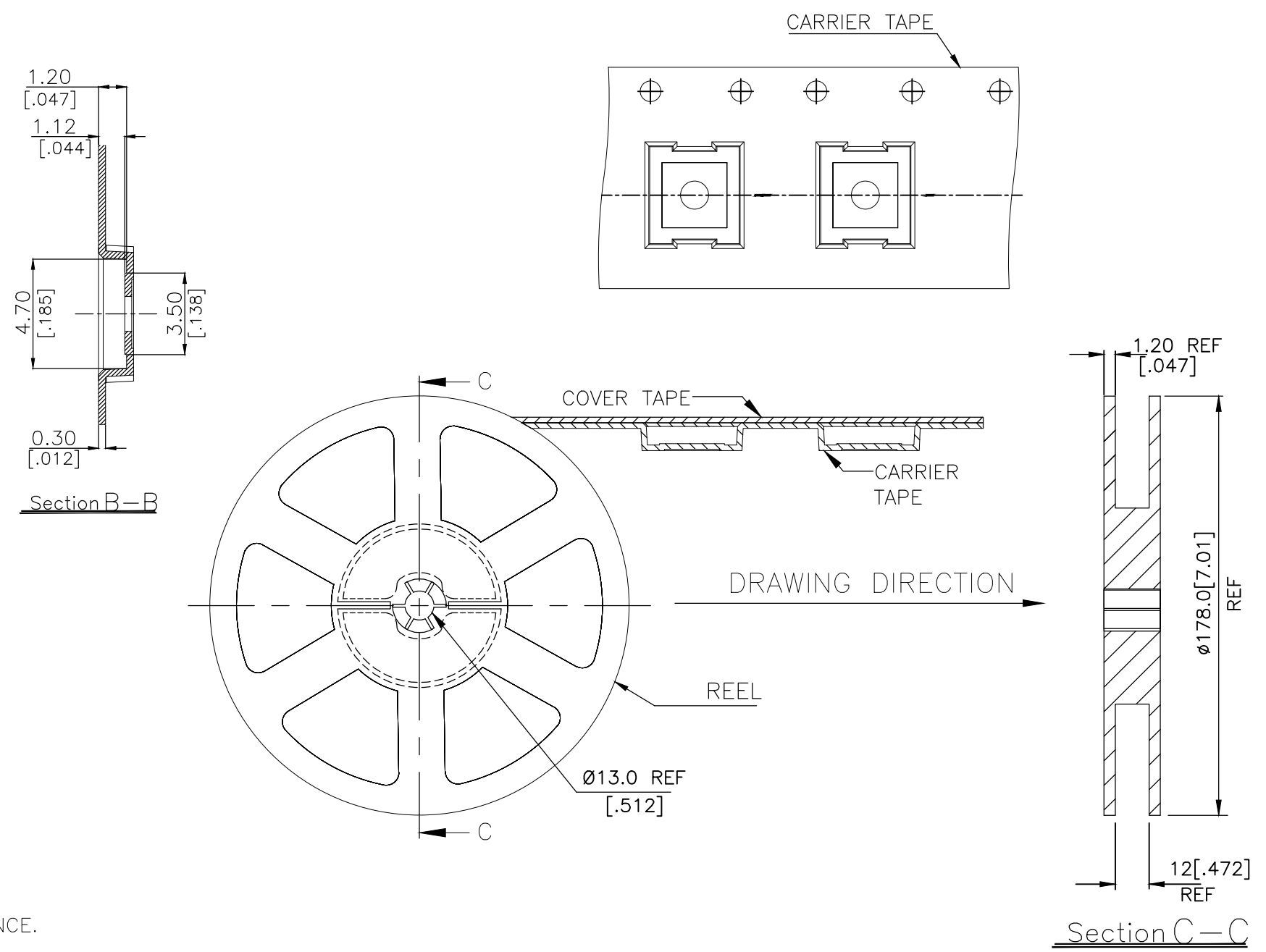

6. PACKAGING:

1. THE TAPE AND REEL ARE SHOWN FOR CUSTOMER APPLICATION REFERENCE. PACKAGING NOTES 3 AND 4 ARE REQUIRED BUT NOT ILLUSTRATED.
2. 1,500 SWITCHES PER REEL.
3. THE REEL, DESICCANT POUCH AND HUMIDITY CARD ARE SEALED IN A MOISTURE BARRIER BAG PER THE CURRENT REVISION OF IPC/JEDEC J-STD-033, MSL 2A REQUIREMENTS.
4. THE MOISTURE BARRIER BAG IS LABELED PER THE CURRENT REVISION OF IPC/JEDEC J-STD-033, MSL 2A REQUIREMENTS.

THIS DRAWING IS A CONTROLLED DOCUMENT.		DWN GANESH C M 04JUL2018	TE Connectivity Ltd.				
DIMENSIONS: mm [INCHES]		CHK ALEXANDER SHARPE 04JUL2018					
TOLERANCES UNLESS OTHERWISE SPECIFIED:		APVD ALEXANDER SHARPE 04JUL2018	NAME SWITCH, TACTILE, LOW-PROFILE, MICRO-MINI, 4.6 x 4.4 x 1.05, J BEND				
0 PLC ± - 1 PLC ± - 2 PLC ± 0.2 [.008] 3 PLC ± - 4 PLC ± - ANGLES ± -		PRODUCT SPEC -	APPLICATION SPEC -				
MATERIAL -		FINISH -	WEIGHT -	SIZE A3	CAGE CODE 00779	DRAWING NO C-2337235	RESTRICTED TO -
CUSTOMER DRAWING			SCALE NTS	SHEET 3 OF 3	REV B		



Компания «ЭлектроПласт» предлагает заключение долгосрочных отношений при поставках импортных электронных компонентов на взаимовыгодных условиях!

Наши преимущества:

- Оперативные поставки широкого спектра электронных компонентов отечественного и импортного производства напрямую от производителей и с крупнейших мировых складов;
- Поставка более 17-ти миллионов наименований электронных компонентов;
- Поставка сложных, дефицитных, либо снятых с производства позиций;
- Оперативные сроки поставки под заказ (от 5 рабочих дней);
- Экспресс доставка в любую точку России;
- Техническая поддержка проекта, помощь в подборе аналогов, поставка прототипов;
- Система менеджмента качества сертифицирована по Международному стандарту ISO 9001;
- Лицензия ФСБ на осуществление работ с использованием сведений, составляющих государственную тайну;
- Поставка специализированных компонентов (Xilinx, Altera, Analog Devices, Intersil, Interpoint, Microsemi, Aeroflex, Peregrine, Syfer, Eurofarad, Texas Instrument, Miteq, Cobham, E2V, MA-COM, Hittite, Mini-Circuits, General Dynamics и др.);

Помимо этого, одним из направлений компании «ЭлектроПласт» является направление «Источники питания». Мы предлагаем Вам помощь Конструкторского отдела:

- Подбор оптимального решения, техническое обоснование при выборе компонента;
- Подбор аналогов;
- Консультации по применению компонента;
- Поставка образцов и прототипов;
- Техническая поддержка проекта;
- Защита от снятия компонента с производства.



Как с нами связаться

Телефон: 8 (812) 309 58 32 (многоканальный)

Факс: 8 (812) 320-02-42

Электронная почта: org@eplast1.ru

Адрес: 198099, г. Санкт-Петербург, ул. Калинина, дом 2, корпус 4, литера А.