



# CY8CKIT-026 CAN and LIN Shield Kit Guide

Doc. No. 002-03798 Rev. \*B

Cypress Semiconductor  
198 Champion Court  
San Jose, CA 95134-1709  
Phone (USA): 800.858.1810  
Phone (Intl): +1.408.943.2600  
[www.cypress.com](http://www.cypress.com)

## Copyrights

© Cypress Semiconductor Corporation, 2015-2016. The information contained herein is subject to change without notice. Cypress Semiconductor Corporation assumes no responsibility for the use of any circuitry other than circuitry embodied in a Cypress product. Nor does it convey or imply any license under patent or other rights. Cypress products are not warranted nor intended to be used for medical, life support, life saving, critical control or safety applications, unless pursuant to an express written agreement with Cypress. Furthermore, Cypress does not authorize its products for use as critical components in life-support systems where a malfunction or failure may reasonably be expected to result in significant injury to the user. The inclusion of Cypress products in life-support systems application implies that the manufacturer assumes all risk of such use and in doing so indemnifies Cypress against all charges.

Any Source Code (software and/or firmware) is owned by Cypress Semiconductor Corporation (Cypress) and is protected by and subject to worldwide patent protection (United States and foreign), United States copyright laws and international treaty provisions. Cypress hereby grants to licensee a personal, non-exclusive, non-transferable license to copy, use, modify, create derivative works of, and compile the Cypress Source Code and derivative works for the sole purpose of creating custom software and or firmware in support of licensee product to be used only in conjunction with a Cypress integrated circuit as specified in the applicable agreement. Any reproduction, modification, translation, compilation, or representation of this Source Code except as specified above is prohibited without the express written permission of Cypress.

Disclaimer: CYPRESS MAKES NO WARRANTY OF ANY KIND, EXPRESS OR IMPLIED, WITH REGARD TO THIS MATERIAL, INCLUDING, BUT NOT LIMITED TO, THE IMPLIED WARRANTIES OF MERCHANTABILITY AND FITNESS FOR A PARTICULAR PURPOSE. Cypress reserves the right to make changes without further notice to the materials described herein. Cypress does not assume any liability arising out of the application or use of any product or circuit described herein. Cypress does not authorize its products for use as critical components in life-support systems where a malfunction or failure may reasonably be expected to result in significant injury to the user. The inclusion of Cypress' product in a life-support systems application implies that the manufacturer assumes all risk of such use and in doing so indemnifies Cypress against all charges.

Use may be limited by and subject to the applicable Cypress software license agreement.

PSoC Creator™ is a trademark and CapSense® and PSoC® are registered trademarks of Cypress Semiconductor Corporation. All other trademarks are the property of their respective owners.

## Flash Code Protection

Cypress products meet the specifications contained in their particular Cypress PSoC Datasheets. Cypress believes that its family of PSoC products is one of the most secure families of its kind on the market today, regardless of how they are used. There may be methods, unknown to Cypress, that can breach the code protection features. Any of these methods, to our knowledge, would be dishonest and possibly illegal. Neither Cypress nor any other semiconductor manufacturer can guarantee the security of their code. Code protection does not mean that we are guaranteeing the product as "unbreakable."

Cypress is willing to work with the customer who is concerned about the integrity of their code. Code protection is constantly evolving. We at Cypress are committed to continuously improving the code protection features of our products.

# Contents



<b>1. Introduction</b>	<b>6</b>
1.1 Kit Contents .....	6
1.2 Getting Started.....	7
1.3 Additional Learning Resources.....	9
1.4 Technical Support.....	10
1.5 Acronyms.....	10
1.6 Document Conventions .....	10
<b>2. Installation</b>	<b>11</b>
2.1 Before You Begin.....	11
2.2 Install Software .....	12
2.3 Uninstall Software.....	14
2.4 Install Hardware.....	14
<b>3. Hardware</b>	<b>15</b>
3.1 System Block Diagram .....	15
3.2 CAN Physical Layer Transceiver Circuits.....	17
3.3 LIN Physical Layer Transceiver Circuits.....	20
3.4 Status LEDs.....	22
3.5 Port Options with CY8CKIT-042/044 Pioneer Kit .....	23
3.6 Power Supply Configurations .....	24
<b>4. Kit Operation</b>	<b>30</b>
4.1 Default Jumper Settings on CY8CKIT-026.....	30
4.2 CAN Communication Hardware Setup .....	30
4.3 Using CAN Bus Analyzer Tool.....	32
4.4 LIN Communication Hardware Setup .....	34
4.5 Using LIN Bus Analyzer Tool.....	35
<b>5. Example Projects</b>	<b>37</b>
5.1 Using the Kit Example Projects .....	37
5.2 CAN_Simplex_Tx_CY8CKIT-044 .....	38
5.3 CAN_Simplex_Rx_CY8CKIT-044.....	41
5.4 LIN_Slave_CY8CKIT-042.....	45
5.5 LIN_Slave_CY8CKIT-044.....	49
5.6 Multiple_LIN_Slave_CY8CKIT-042 .....	49
<b>Appendix</b>	<b>54</b>
Schematics .....	54
Gerber Files .....	58
Bill of Materials .....	62

# Safety Information



## Regulatory Compliance

The CY8CKIT-026 CAN and LIN Shield Kit is intended for use as a development platform for hardware or software in a laboratory environment. The board is an open system design, which does not include a shielded enclosure. This may cause interference to other electrical or electronic devices in close proximity. In a domestic environment, this product may cause radio interference. In such cases, you may be required to take adequate preventive measures. In addition, this board should not be used near any medical equipment or RF devices.

Attaching additional wiring to this product or modifying the product operation from the factory default may affect its performance and cause interference with other apparatus in the immediate vicinity. If such interference is detected, suitable mitigating measures should be taken.

The CAN and LIN Shield Kit, as shipped from the factory, has been verified to meet with the requirements of CE as a Class A product.



The CAN and LIN Shield Kit contains ESD-sensitive devices. Electrostatic charges readily accumulate on the human body and any equipment, and can discharge without detection. Permanent damage may occur on devices subjected to high-energy discharges. Proper ESD precautions are recommended to avoid performance degradation or loss of functionality. Store unused kit boards in the protective shipping package.



### End-of-Life/Product Recycling

This kit has an end-of life five years from the date of manufacture mentioned on the back of the box. Contact your nearest recycler for discarding the kit.

## **General Safety Instructions**

### **ESD Protection**

ESD can damage boards and associated components. Cypress recommends that you perform procedures only at an ESD workstation. If such a workstation is not available, use appropriate ESD protection by wearing an antistatic wrist strap attached to the chassis ground (any unpainted metal surface) on your board when handling parts.

### **Handling Boards**

CAN and LIN Shield Kit boards are sensitive to ESD. Hold the board only by its edges. After removing the board from its box, place it on a grounded, static-free surface. Use a conductive foam pad if available. Do not slide the board over any surface.

# 1. Introduction



Thank you for your interest in the CY8CKIT-026 CAN and LIN Shield Kit. This kit is intended to demonstrate the CAN and LIN bus communications in Cypress's PSoC<sup>®</sup> products.

The CY8CKIT-026 CAN and LIN Shield Kit is an Arduino compatible shield board that is used with several Cypress kits such as the CY8CKIT-042 PSoC 4 Pioneer Kit/CY8CKIT-044 PSoC 4 M-Series Pioneer Kit or FM4-176L-S6E2GM - ARM<sup>®</sup> Cortex<sup>®</sup>-M4 MCU Pioneer Kit. It enables you to evaluate the Controller Area Network (CAN) and Local Interconnect Network (LIN) slave communication capability of Cypress devices. You can design your own projects with easy-to-use CAN and LIN slave components in Cypress's PSoC Creator<sup>™</sup> software, or by altering code examples provided with this kit.

This kit guide provides details on the kit contents, hardware, example projects, schematics, and BOM.

## 1.1 Kit Contents

The CY8CKIT-026 CAN and LIN Shield Kit contains the following, as shown in [Figure 1-1](#):

- CAN and LIN Shield Board
- Three jumper wires (5 inches each)
- Three jumper wires (4 inches each)
- Four connectors (one 10 × 1, two 8 × 1 and one 6 × 1)
- Quick Start Guide

Figure 1-1. CY8CKIT-026 CAN and LIN Shield Kit



Inspect the contents of the kit; if anything is missing, contact your nearest [Cypress sales office](#) for assistance. Go to [www.cypress.com/support](http://www.cypress.com/support) for more information on Cypress sales offices and support.

### 1.1.1 Kit Compatibility

This kit contains an Arduino compatible shield board and requires other Cypress kits (Arduino compatible) to use it. It is designed to add CAN and LIN capabilities to the [PSoC 4 Series Pioneer Kits](#) (CY8CKIT-042/44) and FM4 kits such as [FM4-176L-S6E2GM - ARM Cortex-M4 MCU Pioneer Kit](#).

This kit is also compatible with any other general Arduino compatible Kit which supports CAN/LIN protocol.

CAN and LIN are communication protocols and require more than one CAN or LIN node to set up communication between nodes. Therefore, it is recommended to have two CY8CKIT-044 Pioneer Kits or other compatible kits and two CY8CKIT-026 CAN and LIN Shield Kits. This enables you to set up CAN communication between two CAN nodes. An alternative recommendation is to have a CAN or LIN bus emulator or analyzer. This enables you to emulate a CAN or LIN node to communicate with the PSoC CAN or LIN controller. See sections [Using CAN Bus Analyzer Tool on page 32](#) and [Using LIN Bus Analyzer Tool on page 35](#) for more details on using a CAN analyzer or LIN analyzer tool with this kit.

For detailed information about the differences between PSoC 4 devices, go to [www.cypress.com/psoc](http://www.cypress.com/psoc). For more information about Cypress kits, go to the Cypress Store at [www.cypress.com/shop](http://www.cypress.com/shop).

## 1.2 Getting Started

This guide will help you to get acquainted with the CY8CKIT-026 CAN and LIN Shield Kit:

- The [Installation chapter on page 11](#) describes the installation of the kit software. This includes the PSoC Creator IDE to develop and debug the applications, and PSoC Programmer to program the `.hex` files on to the device.
- The [Hardware chapter on page 15](#) details the hardware content of the kit and the hardware operation.
- The [Kit Operation chapter on page 30](#) explains you on how to set-up the hardware connections in order to establish CAN and LIN communication using CY8CKIT-026.
- The [Example Projects chapter on page 37](#) describes code examples that will help you understand how to create your own CAN and LIN communication projects on PSoC 4.
- The [Appendix chapter on page 54](#) provides schematics, layout and the bill of materials (BOM).

Refer to the [kit web page](#) for the latest information on using this kit with various Cypress devices. The web page will be updated as new devices and development kits compatible with this shield are released to the market.

## 1.2.1 Beginner Resources

An overview of PSoC devices is available at [www.cypress.com/psoc](http://www.cypress.com/psoc). The web page includes a list of PSoC device families, integrated design environments (IDEs), and associated development kits. In addition, refer to the following documents to get started with PSoC 4 devices and CAN/LIN communication:

- [AN79953 - Getting Started with PSoC® 4](#)
- [CE97311 - PSoC® 4 M: CAN Simplex Communication with CapSense®](#)
- [CE96999 - Basic LIN Slave Implementation in PSoC® 4](#)
- [PSoC Creator 101 Training Series](#)
- [CE211027 - CAN Communication between FM4-S6E2Gx Series and PSoC® 4 M-Series using the CY8CKIT-026 CAN and LIN Shield Kit](#)

## 1.2.2 Hardware Requirements

CY8CKIT-026 plugs into any Arduino™ hardware-compatible development platforms from Cypress. This Kit provides example projects targeting the CY8CKIT-042 PSoC 4 Pioneer Kit and CY8CKIT-044 PSoC 4 M-Series Pioneer Kit. For FM4 Kit CAN example project and hardware connections, please refer to the Code Example [CE211027 - CAN Communication between FM4-S6E2Gx Series and PSoC® 4 M-Series using the CY8CKIT-026 CAN and LIN Shield Kit](#).

[Figure 1-2](#) shows how the CY8CKIT-026 Kit connects to the CY8CKIT-044 Kit.

Figure 1-2. CY8CKIT-026 Connected to CY8CKIT-044

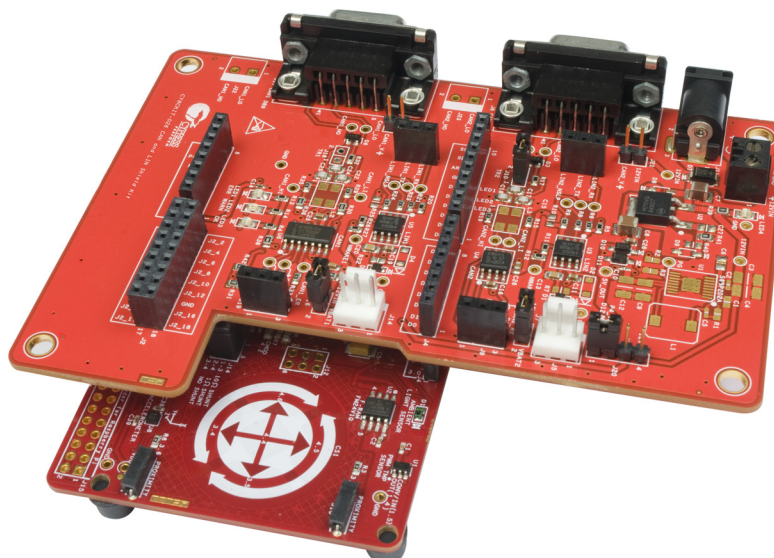

You can purchase the CY8CKIT-042 kit from [www.cypress.com/CY8CKIT-042](http://www.cypress.com/CY8CKIT-042) and the CY8CKIT-044 kit from [www.cypress.com/CY8CKIT-044](http://www.cypress.com/CY8CKIT-044).

## 1.2.3 Software Requirements

The CY8CKIT-026 kit does not have any programmable/configurable device onboard, so it does not need any software for configuration. However, the PSoC device present on baseboards, such as CY8CKIT-042 or CY8CKIT-044, requires firmware, which you can develop with the PSoC Creator IDE (Version 3.3 SP1 or later).



### 1.2.3.1 PSoC Creator

**PSoC Creator** allows concurrent hardware and application firmware design of PSoC 3, PSoC 4, and PSoC 5LP systems. PSoC systems are designed using classic, familiar, schematic-capture technology supported by pre-verified, production ready PSoC Components™.

PSoC Components are analog and digital virtual chips represented by icons that you can drag and drop into a design and configure to suit a broad array of application requirements. You can configure each Component in the rich, mixed-signal Cypress Component Catalog with the Component Customizer tool. These Components include a full set of dynamically generated API libraries. After you have configured the PSoC system, you can write, compile, and debug the firmware within PSoC Creator, or export the firmware to other IDEs such as those from IAR, Keil, and Eclipse.

You can download the latest version of the PSoC Creator software from [www.cypress.com/psoccreator](http://www.cypress.com/psoccreator). Refer to the Release Notes for the minimum and recommended system requirements.

### 1.2.3.2 PSoC Programmer

The PSoC Programmer software is used to program the PSoC 4 devices on the CY8CKIT-042 kit and CY8CKIT-044 kit with hex files. PSoC Programmer is installed along with PSoC Creator. You can also download PSoC Programmer separately at [www.cypress.com/psocprogrammer](http://www.cypress.com/psocprogrammer).

## 1.3 Additional Learning Resources

Visit [www.cypress.com](http://www.cypress.com) for additional learning resources in the form of datasheets, technical reference manuals, and application notes.

Code Example [CE97311](#) describes the implementation of CAN bus communication between two PSoC 4 devices. It explains how to send and receive CAN messages. It has two example projects which describe how to transmit/receive CAN messages using the CAN and LIN Shield Kit and CY8CKIT-044 PSoC 4 M-Series Pioneer Kit.

Code Example [CE96999](#) describes the implementation of LIN bus communication using PSoC. It explains how to send and receive LIN messages. It has two example projects which describe how to transmit/receive LIN messages using the CAN and LIN Shield Kit and CY8CKIT-042/CY8CKIT-044 PSoC 4 Pioneer Kits.

Code Example [CE211027](#) describes the implementation of CAN bus communication between FM4-S6E2Gx Series and PSoC 4 M-Series. FM4 acts as Transmitter and PSoC 4 M acts as a receiver which changes the RGB LED color based on the commands received from the FM4.

## 1.4 Technical Support

For assistance, go to our support web page ([www.cypress.com/support](http://www.cypress.com/support)) or contact our customer support at +1(800) 541-4736 Ext. 2 (in the USA), or +1 (408) 943-2600 Ext. 2 (International).

## 1.5 Acronyms

Table 1-1. Acronyms

Acronym	Definition
BOM	Bill of Materials
CAN	Controlled Area Network
DLC	Data Length Code
IDE	Integrated Design Environment
LIN	Local Interconnect Network
USB	Universal Serial Bus

## 1.6 Document Conventions

Table 1-2. Document Convention for Guides

Acronym	Definition
Courier New	Displays file locations, user entered text, and source code: C:\...cd\licc\
<i>Italics</i>	Displays file names and reference documentation: Read about the sourcefile.hex file in the PSoC Creator User Guide
<b>[Bracketed, Bold]</b>	Displays keyboard commands in procedures: <b>[Enter] or [Ctrl] [C]</b>
File > Open	Represents menu paths: File > Open > New Project
<b>Bold</b>	Displays commands, menu paths, and icon names in procedures: Click the <b>File</b> icon and then click <b>Open</b> .
Times New Roman	Displays an equation: $2 + 2 = 4$
Text in gray boxes	Describe s Cautions or unique functionality of the product.

## 2. Installation



This chapter describes the steps to install the software tools and packages on a computer for using the CAN and LIN Shield Kit along with PSoC Pioneer Kits. This includes the IDE on which the projects will be built and used for programming.

### 2.1 Before You Begin

All Cypress software installations require administrator privileges, but these are not required to run the software after it is installed. Close any other Cypress software that is currently running before installing the kit software.

**Note:** By default, the kit contents are installed in `C:\Program Files\Cypress\CY8CKIT-026 CAN and LIN SHIELD KIT\<version>` for a 32-bit machine and `C:\Program Files (x86)\Cypress\CY8CKIT-026 CAN and LIN SHIELD KIT\<version>` for a 64-bit machine. This folder will contain the kit example projects. To open the examples, it is recommended to use the procedure described in the Code Example documents. That procedure will create an editable copy of the example in a path that you chose so that the original installed example will not be modified.

If you use a PSoC baseboard such as the CY8CKIT-042 or CY8CKIT-044 with the CY8CKIT-026 CAN and LIN Shield Kit, you will require the PSoC Creator and PSoC Programmer software programs to be installed before the kit can be used. If you run the CY8CKIT-026 installer file (`CY8CKIT026Setup.exe`), this will install PSoC Creator and Programmer. Otherwise, you can install these programs by downloading them from the following locations:

- [PSoC Programmer](#)
- [PSoC Creator](#)

## 2.2 Install Software

### 2.2.1 Installation from Internet

Perform these steps to install the CY8CKIT-026 CAN and LIN Shield Kit software from the internet (this is done to ensure the latest software is installed):

1. Go to kit [web page](#).
2. Download and run the installer executable file (CY8CKIT026Setup.exe).
3. Run the installer executable file after it is downloaded.
4. Select the folder to install the CY8CKIT-026 related files. Choose the directory and click **Next** (see [Figure 2-1](#)).

Figure 2-1. Installation Folder

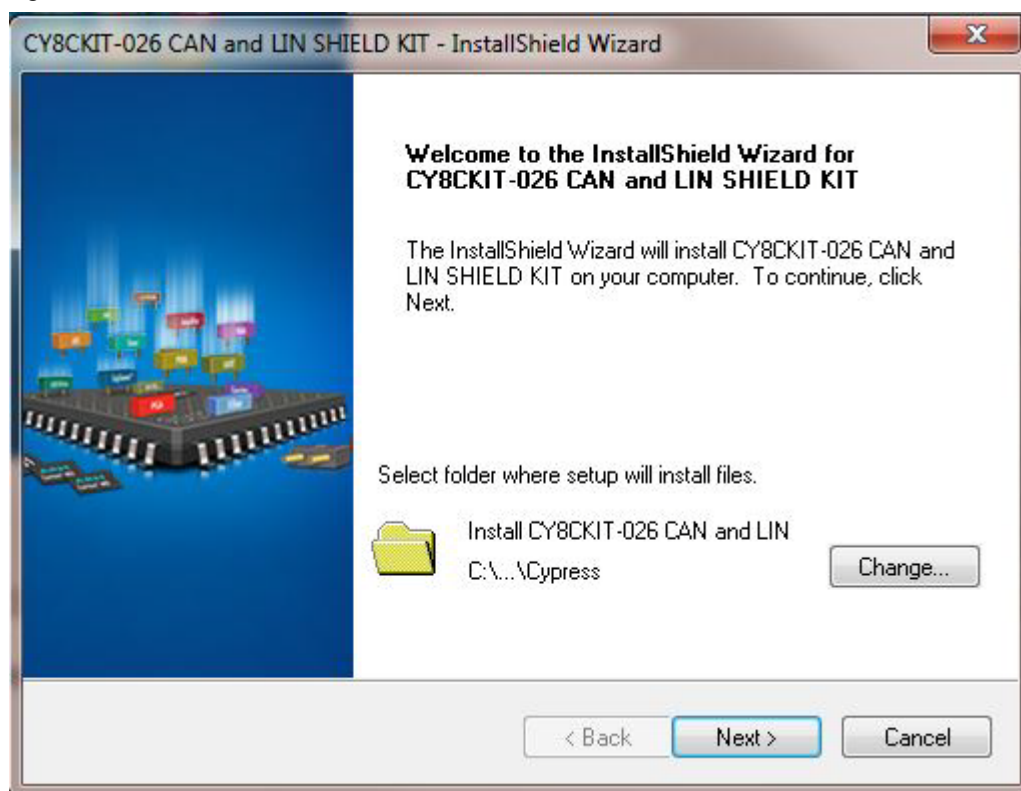

5. Select the **Installation Type** as Typical and click **Next** (see Figure 2-2).

Figure 2-2. Installation Type Options

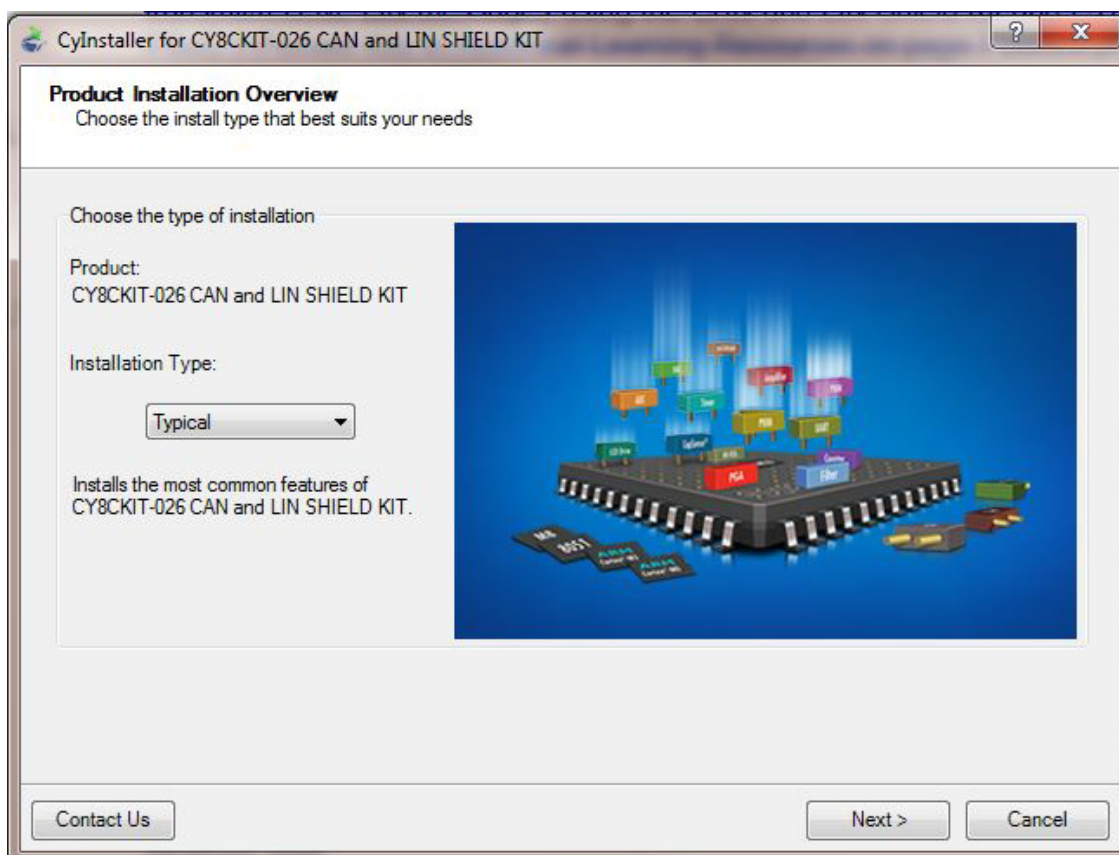

6. Read and accept the End-User License Agreement and click Next to proceed with the installation. After the installation is complete, the kit contents are available at the following location: `C:\Program Files (x86)\Cypress\CY8CKIT-026 CAN and LIN SHIELD KIT\<version>`

**Note:** Follow all on-screen prompts to proceed with the installation. When installing the kit software, the installer checks if the prerequisite software is installed in your system. These include PSoC Creator, PSoC Programmer, Windows Installer, .NET (v4.0), and Acrobat Reader. If these applications are not installed, the installer prompts you to download and/or install them.

## 2.3 Uninstall Software

Perform these steps to uninstall the CY8CKIT-026 CAN and LIN Shield Kit software:

1. Go to **Start > All Programs > Cypress > Cypress Update Manager** and select the **Uninstall** button that corresponds to the kit software. Follow the on-screen prompts to uninstall the software. This is a program that is installed along with other Cypress software.
2. Go to **Start > Control Panel > Programs and Features** for Windows 7 or **Add/Remove Programs** for Windows XP; select the **Uninstall/Change** button.

## 2.4 Install Hardware

Perform these steps to install the hardware:

1. The Shield board must be physically attached to the Arduino header of the CY8CKIT-042/044 Pioneer Kit.  
**Note:** This kit guide explains how to use this Shield Kit with Arduino headers of the CY8CKIT-044/042 Pioneer Kit. You can also attach this board to any Arduino based kit (controller must support CAN/LIN protocol). Modify pin assignments of the example projects to use with other kits. See [Port Options with CY8CKIT-042/044 Pioneer Kit on page 23](#) for pin assignment details and limitations of using with CY8CKIT-044/042 Pioneer Kit Arduino ports.
2. Connect a USB Mini cable to your computer, to program this kit's code examples into the PSoC device. Follow the instructions in the QSG (Quick Start Guide) documentation of the corresponding kit to connect it to your computer.
3. For the CAN example evaluation, perform these steps:
  - a. Connect two CAN and LIN shield boards together with a male-to-male, 9-pin, RS-232 cable with "straight-through" connections, as shown in [Figure 4-1 on page 31](#), or
  - b. Connect a CAN analyzer to DB9 female connector of the Shield Kit.For the LIN example evaluation, connect VCC, LIN bus, and GND of the LIN analyzer to connector J5 or J14 of the Shield Kit.

# 3. Hardware



## 3.1 System Block Diagram

The actual kit hardware files i.e., Schematic, Gerber, BOM etc are available in the installer directory i.e., <Install\_Directory>\CY8CKIT-026 CAN and LIN SHIELD KIT\<version>\Hardware

The CAN and LIN Shield Kit hardware consists of the following functional blocks:

- 2-CAN transceiver circuits (TJA1051T and TJA1055T)
- 2-LIN transceiver circuits in slave configuration (TJA1020)
- Three status indicator LEDs
- Arduino header
- 12 V input Power Jack and Screw terminals for the same
- Power circuitry for 12 V to 5 V dc conversion
- PMIC for 12 V to 5 V dc conversion (not populated)

The primary functional blocks of this Shield Kit are the four transceiver circuits: two CAN transceiver circuits and two LIN transceiver circuits. Each of these transceiver circuits enables a digital CMOS PSoC device to interface with a physical CAN or LIN bus, respectively. Without these transceiver circuits, it is impossible for CMOS devices to communicate with other CAN or LIN nodes on a CAN or LIN bus.

The LEDs functional block consists of three active-low LEDs that can provide indications. These LEDs are driven by PSoC pins. The Arduino connector connects the configured PSoC I/O pins to the various circuits on the Shield board. [Figure 3-1](#) shows the CY8CKIT-026 kit components.

Figure 3-1. CY8CKIT-026 CAN and LIN Shield Kit

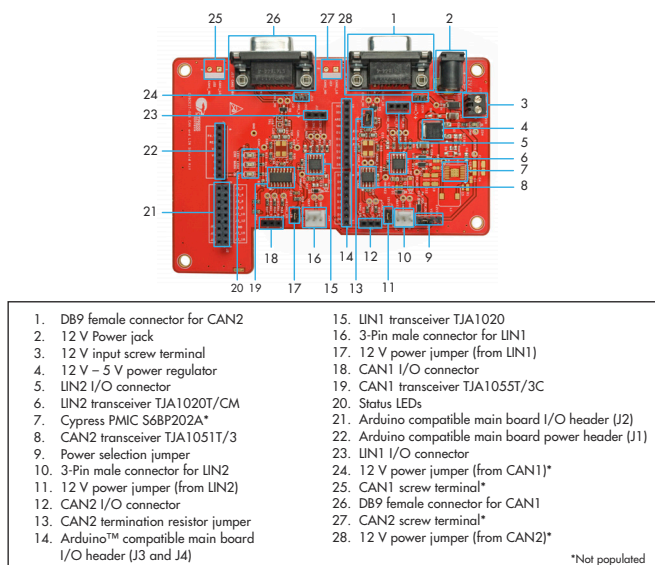

Figure 3-2 and Figure 3-3 show the top and bottom view of the CY8CKIT-026.

Figure 3-2. CY8CKIT-026 (Top View)

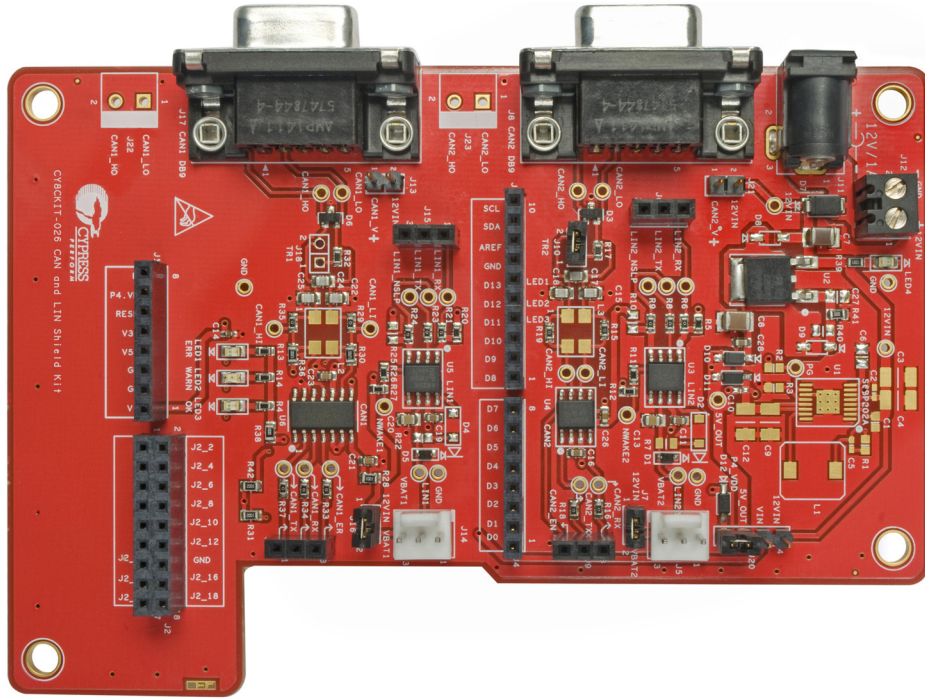
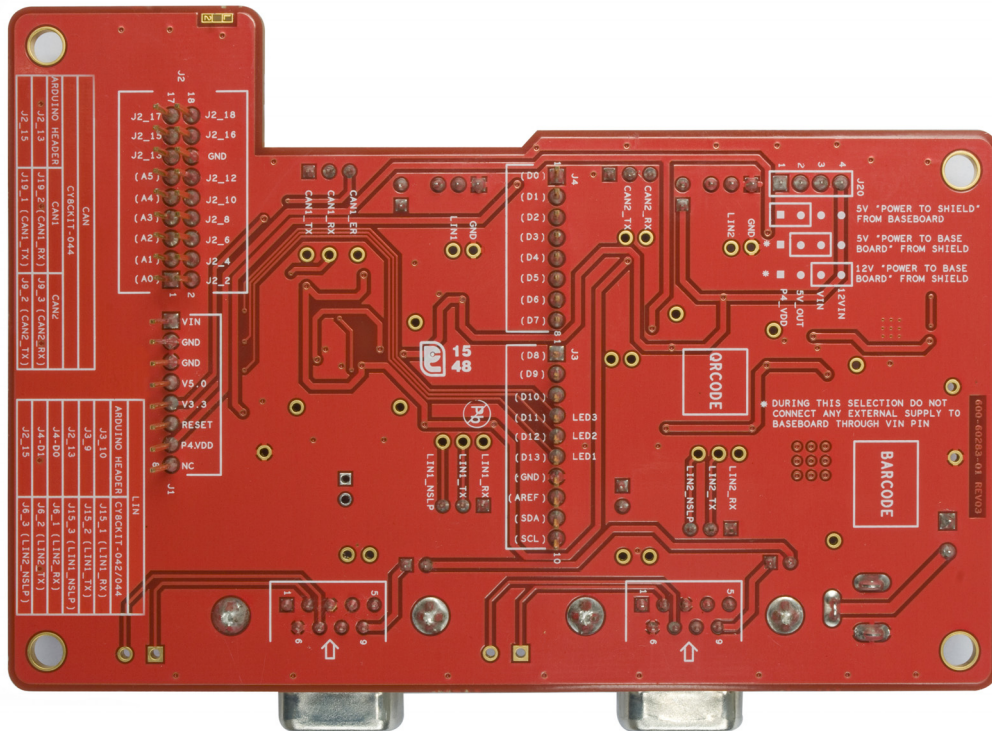

Figure 3-3. CY8CKIT-026 (Bottom View)





## 3.2 CAN Physical Layer Transceiver Circuits

The CY8CKIT-026 has two CAN transceivers: one is low speed (up to 125 Kbps baud rate) and fault tolerant, and the other is high speed (up to 2 Mbps baud rate). The PSoC 4M device supports two CAN modules, so these two transceivers enable you to use both of them to connect to CAN networks.

The CAN physical layer transceiver circuits (CAN1 Transceiver and CAN2 Transceiver) on the shield board use TJA1055T and TJA1051T CAN transceiver devices. These devices translate differential CAN bus signals to and from digital CMOS signals.

### ■ CAN1 Transceiver (TJA1055T)

Three signals are used between this circuit and the CAN (PSoC 4) controller. These signals are CAN1\_RX, CAN1\_TX, and CAN1\_ERR. Data signals on the CAN bus are driven to the PSoC CAN1\_RX signal. Data signals on the PSoC CAN1\_TX signal are driven onto the CAN bus. The CAN1\_ER signal is used to indicate an error event. See the [TJA1055T](#) device datasheet for details on each of these three pins of the CAN transceiver.

### ■ CAN2 Transceiver (TJA1051T)

Three signals are used between this circuit and the CAN (PSoC 4) controller. These signals are CAN\_RX, CAN\_TX, and CAN\_EN. Data signals on the CAN bus are driven to the PSoC CAN2\_RX signal. Data signals on the PSoC CAN2\_TX signal are driven onto the CAN bus. The CAN\_EN signal enables and disables the CAN transceiver. See the [TJA1051T](#) device datasheet for details on each of these three pins of the CAN transceiver.

### 3.2.1 CAN Bus Clock Accuracy

For accurate CAN communication, a CAN controller device must typically have a clock source with a frequency tolerance of 0.5% or less for bit-rates faster than 125 Kbps and at least 1.58% for 125 Kbps or slower bit-rates. Therefore, the device used as the CAN controller must meet this requirement. Otherwise, an external clock source that is more accurate must be used. But, PSoC 4 has a great feature where you can trim the internal IMO clock up to 0.5% accuracy. See [CE97311](#) code example for details on the clock configuration of this kit's code examples.

### 3.2.2 CAN Bus Connector

[Table 3-1](#) shows the pinout of the CAN DB9 connectors (J8 and J17) on the shield board. The CAN Bus connectors (DB9 connectors) for the two transceiver circuits have the same pin configuration.

Table 3-1. CAN Connector Point

Pin	Signal
1	NC
2	CAN_L
3	GND
4	NC
5	NC
6	GND
7	CAN_H
8	NC
9	NC (VIN = 12 V)

By default, pin 9 of the CAN connector is left floating. However, if the jumper (J13 for CAN1 transceiver and J21 for CAN2 transceiver) is populated, pin 9 of the CAN connector is connected to the VIN power rail of the Shield board. This is useful if you want to power up other CAN nodes through the CAN connector or if you want to power up the Shield board from the power supply of some other CAN node.

**Caution:** Ensure extra care when populating jumpers J13 or J21. The shield Kit or Pioneer Kit can be damaged if the shield has it's own power supply powering the VIN rail and a different power supply is connected through pin 9 of the CAN connectors.

### 3.2.3 CAN Bus Termination for CAN1 Transceiver

The CAN specification requires that CAN nodes located physically at the end of the CAN bus must terminate the CAN differential signals with  $120\Omega$ . TJA1055 has CAN Bus termination pins as RTH and RTL which are connected to CAN\_H and CAN\_L with  $120\Omega$  respectively.

### 3.2.4 CAN Bus Termination for CAN2 Transceiver

The CAN specification requires that CAN nodes located physically at the end of the CAN bus must terminate the CAN differential signals with  $120\Omega$ . The Shield Kit features a  $120\Omega$  termination resistor (R17) that can be enabled or disabled by using jumper J10. If J10 is populated, the termination resistor is active. If J10 is not populated, the termination resistor is not active.

By default, the termination resistor is active (J10 is populated).

Figure 3-4. J10 Jumper

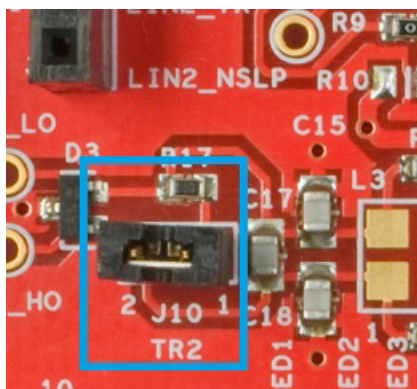

### 3.2.5 Choke Footprint

A footprint for a common-mode signal suppression choke is available on the shield board for both the transceiver circuits, but these are not populated. These footprints can be populated with a B82789C0 (or equivalent) choke to suppress common-mode signals on the CAN bus. **If a choke component is mounted on the L2 footprint (for CAN1 transceiver), resistors R29 and R35 must be removed from the board. If a choke component is mounted on the L3 footprint (for CAN2 transceiver), resistors R15 and R19 must be removed from the board.** The choke component has no effect if these two resistors are not removed.

Figure 3-5. Choke Footprints for CAN1 and CAN2 transceivers

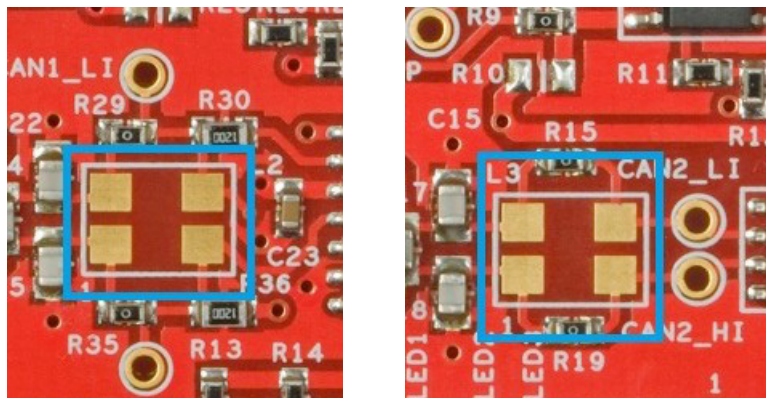

### 3.2.6 CAN Signal Connector for CAN1 Transceiver

Table 3-2 shows the pinout of the 3-pin female CAN signal connector (J19) on the shield board.

Table 3-2. CAN1 Signal Connector Pinout

Pin	Signal
1	CAN1_TX
2	CAN1_RX
3	CAN1_ER

CAN1\_TX and CAN1\_RX pins needs to be connected to the CAN TX pin, CAN\_RX pin of the PSoC (microcontroller) respectively, using external connecting wires. CAN1\_ER pin is used for error indication which should be connected to a GPIO pin of the microcontroller. These connections are not hard-wired on the board so that maximum flexibility for the CAN pin placement in the microcontroller is provided.

### 3.2.7 CAN Signal Connector for CAN2 Transceiver

Table 3-3 shows the pinout of the 3-pin female CAN signal connector (J9) on the shield board.

Table 3-3. CAN2 Signal Connector Pinout

Pin	Signal
1	CAN2_EN
2	CAN2_TX
3	CAN2_RX

CAN2\_TX and CAN2\_RX pins need to be connected to the CAN TX pin, CAN\_RX pin of the PSoC (microcontroller) respectively, using external connecting wires. CAN2\_EN pin is used enable/disable the transceiver which should be connected to the CAN\_EN pin of the microcontroller. The transceiver is enabled by default. These connections are not hard-wired on the board so that maximum flexibility for the CAN pin placement in the microcontroller is provided.

### 3.3 LIN Physical Layer Transceiver Circuits

The CY8CKIT-026 has two LIN transceivers. Since some PSoC 4 devices support two LIN slaves, these two transceivers enable you to use both of them simultaneously.

The two LIN physical layer transceiver circuits on the shield board use a TJA1020 LIN transceiver device. This device translates high-voltage LIN bus signals to and from digital CMOS signals with standard TTL voltage levels.

Three signals are used between each LIN circuit and the LIN (PSoC 4) controller. For the LIN1 circuit, the three signals are: LIN1\_RX, LIN1\_TX, and LIN1\_NSLP. For the LIN2 circuit, the signals are: LIN2\_RX, LIN2\_TX, and LIN2\_NSLP. Data signals on the LIN bus are sent to the PSoC by the LINx\_RX signal. Data signals driven by the PSoC on the LINx\_TX signal will be driven onto the LIN bus. The LINx\_NSLP signals are used to put the LIN transceiver device in and out of sleep.

By default, there are no pull-up resistors on the LINx\_TX signals. A pull-up resistor footprint is provided (R25 on LIN1\_TX and R10 on LIN2\_TX) on each LINx\_TX signal if you want to have a pullup resistor on this signal. See the [TJA1020](#) device datasheet for details on each of the three signals of the LIN transceiver.

#### 3.3.1 LIN Bus Connectors

Figure 3-6 shows the pinout of both of the 3-pin LIN connectors (J14 for LIN1 transceiver and J5 for LIN2 transceiver) on the shield board.

Figure 3-6. LIN Connector Pinouts

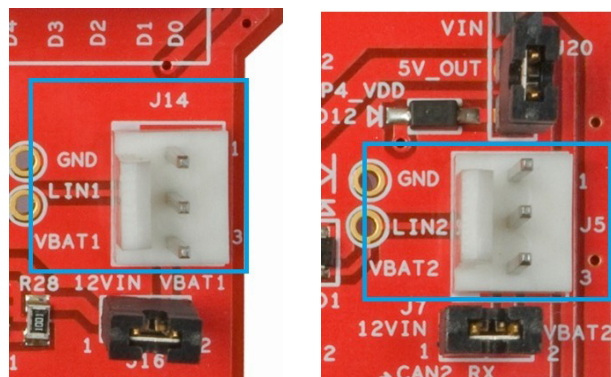

By default, the jumpers J16 and J7 are populated. These connect pin 3 (VBAT1) of the LIN1 connector and pin 3 (VBAT2) of the LIN2 connector to the VIN power rail of the Shield Kit, respectively. This is useful if you want to power up other LIN nodes/analyzers through either of the LIN connectors, or if you want to power the Pioneer Kit and shield board from the power supply (12 V) of some other LIN node (LIN analyzer).

Ensure extra care when connecting an analyzer to either of the LIN connectors. If the LIN analyzer provides 12 V supply already to its VBAT pin, remove jumper J16 for LIN1 connector and J7 for LIN2 connector or do not power the shield with external 12 V supply through the J11 and J12 connectors.

**Warning:** Since the jumpers J16 and J7 are populated by default, ensure extra care while connecting the LIN analyzer VBAT pin to the shield kit pin. The Shield Kit or Pioneer Kit or the supply adapter can be damaged if the Shield Kit and Pioneer Kit are powered by a power supply at the VIN rail and a different power supply is connected through pin 3 of either of the LIN connectors.

### 3.3.2 Using the LIN Transceiver NWAKE Pins

Both TJA1020 LIN transceiver devices have an NWAKE input that can be used to wake up a sleeping LIN bus without interaction from the PSoC LIN controller. If the NWAKE input needs to be used for either LIN circuit, the signal can be accessed using the test points on the board labeled with NWAKE1 for LIN1 transceiver circuit and NWAKE2 for LIN2 transceiver circuit, respectively, as shown in [Figure 3-7](#).

Figure 3-7. NWAKE Test Points

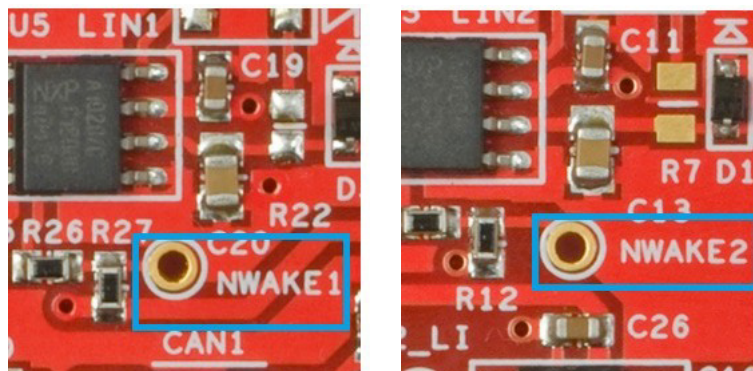

#### 3.3.2.1 LIN Signal Connector for LIN transceivers

[Table 3-4](#) shows the pinout of the 3-pin female LIN signal connector (J15 for LIN1 and J6 for LIN2) on the shield board.

Table 3-4. LIN Signal Connector Pinout

Pin	Signal
1	LINx_RX
2	LINx_TX
3	LINx_NSLP

LINx\_RX, LINx\_TX and LINx\_NSLP pins need to be connected to the LIN RX pin, LIN TX pin and GPIO (enable/sleep control) pin of the microcontroller respectively, using external connecting wires. These connections are not hard-wired on the board so that maximum flexibility for the LIN pin placement in the microcontroller is provided.

### 3.3.3 LIN Master and Slave Configurations

By default, both the LIN circuits are configured for LIN slave operation. [Table 3-5](#) shows how each circuit is populated by default to configure it for the LIN slave mode.

Table 3-5. Configuration for LIN Slave Operation (Default)

Pin	Diode	Resistor	Capacitor
LIN1 (Slave)	D4 is not populated	R22 is not populated	C20 is 1 nF
LIN2 (Slave)	D2 is not populated	R7 is not populated	C13 is 1 nF

The components can be replaced as provided in [Table 3-6](#) to change the circuit from a slave to a master.

Table 3-6. Configurations for LIN Master Operation

Pin	Diode	Resistor	Capacitor
LIN1 (Master)	D4 is PMLL4148L	R22 is 1 kΩ	C20 is 220 pF
LIN2 (Master)	D2 is PMLL4148L	R7 is 1 kΩ	C13 is 220 pF

## 3.4 Status LEDs

The shield board has three status LEDs: Red, Yellow, and Green. The LEDs are active-low, and they must each be driven with a sink current of approximately 2 mA to turn them ON.

The three LEDs (Red, Yellow, and Green) (see [Figure 3-8](#)) are connected to the D13, D12 and D11 pins of the Arduino connector (J3) respectively.

Figure 3-8. Schematic for Status LEDs

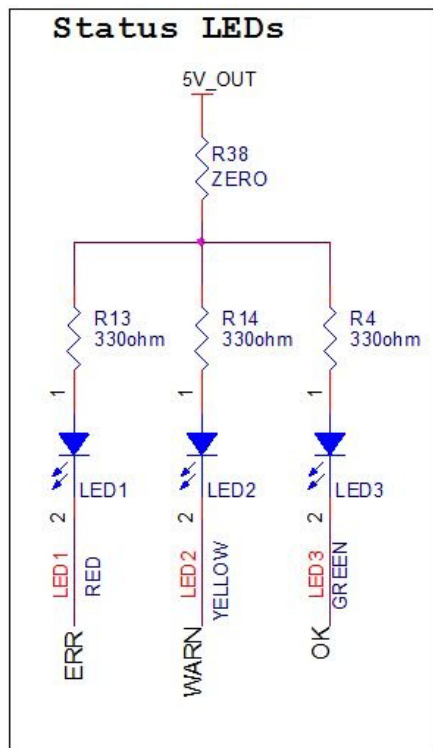

All three LEDs can be completely isolated from the rest of the Pioneer Kit by removing resistor R38, which is a 0Ω resistor. This is useful if the LEDs are not needed, but other circuits on the Shield Kit are needed. In this case, isolating the LEDs ensures that they do not interfere with other circuits that share the same pins.

### 3.5 Port Options with CY8CKIT-042/044 Pioneer Kit

The CAN and LIN Shield Kit connects to the CY8CKIT-042 or CY8CKIT-044 PSoC 4 series Pioneer Kits through the Arduino header connector. [Table 3-7](#) shows how the signals on the CAN and LIN shield board map to the pins on Arduino header of the CY8CKIT-042 and CY8CKIT-044 Pioneer Kits.

Table 3-7. Arduino Port Pin Connections

Arduino Connector	Pin	CY8CKIT-042	CY8CKIT-044	CY8CKIT-026
J1	1	VIN	VIN	VIN
	2	GND	GND	GND
	3	GND	GND	GND
	4	V5.0	V5.0	V5.0
	5	V3.3	V3.3	V3.3
	6	Reset	Reset	Reset
	7	P4.VDD	P4.VDD	P4.VDD
	8	NC	NC	NC
J2	1	P2.0	P2.0	A0
	2	P0.2	P2.6	J2_2
	3	P2.1	P2.1	A1
	4	P0.3	P6.5	J2_4
	5	P2.2	P2.2	A2
	6	P4.VDD	P0.6	J2_6
	7	P2.3	P2.3	A3
	8	P1.5	P4.4	J2_8
	9	P2.4	P2.4	A4
	10	P1.4	P4.5	J2_10
	11	P2.5	P2.5	A5
	12	P1.3	P4.6	J2_12
	13	P0.0	P0.0	J2_13
	14	GND	GND	GND
	15	P0.1	P0.1	J2_15
	16	P1.2	P3.4	J2_16
	17	P1.0	P0.7	J2_17
	18	P1.1	P3.5	J2_18

Table 3-7. Arduino Port Pin Connections (*continued*)

Arduino Connector	Pin	CY8CKIT-042	CY8CKIT-044	CY8CKIT-026
J3	1	P2.6	P0.2	D8
	2	P3.6	P0.3	D9
	3	P3.4	P2.7	D10
	4	P3.0	P6.0	D11
	5	P3.1	P6.1	D12
	6	P0.6	P6.2	D13
	7	GND	GND	GND
	8	P1.7 (AREF)	P1.7 (AREF)	AREF
	9	P4.1 (SDA)	P4.1 (SDA)	SDA
	10	P4.0 (SCL)	P4.0 (SCL)	SCL
J4	1	P0.4	P3.0	D0
	2	P0.5	P3.1	D1
	3	P0.7	P1.0	D2
	4	P3.7	P1.1	D3
	5	P0.0	P1.2	D4
	6	P3.5	P1.3	D5
	7	P1.0	P5.3	D6
	8	P2.7	P5.5	D7

### 3.6 Power Supply Configurations

By default, the CAN and LIN shield board is powered from the Baseboard (CY8CKIT-042/044) by shorting pins 1 and 2 of the 4-pin (1x4) connector (J20). This supplies 5 V to the shield board. Note that this will only allow CAN2 to be used since CAN1, LIN1 and LIN2 require a 12 V supply.



### 3.6.1 12 V Supply Input

A power jack (J11) is provided on the kit to give a 12 V/1 A input supply to the board. In addition, a screw terminal (J12) is provided for a power supply of up to 12 V/1 A for the same. Maximum input supply limit is 20 V/1 A, exceeding it may damage the board.

**Warning:** The supply should only be given to any one connector. While supplying the power through screw terminals, ensure that the polarities are proper as specified on the kit. It is recommended to use short circuit protected power supply cables.

Figure 3-9. Power Jack Schematic

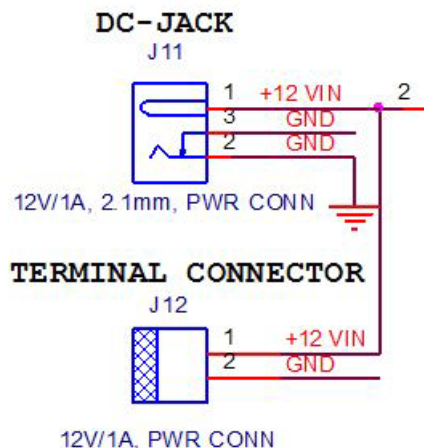

The Shield Kit has a pin on each CAN and LIN header (J17, J8, J14, and J5) that can be connected to the VIN power supply of the kit. Using this option, you can power the Shield Kit with 12 V from any one of the CAN/LIN connections. Another reason to provide this option is to power other CAN and LIN shield boards (connected through CAN/LIN connectors) using this 12 V supply pin. With this, you can avoid using multiple power adapters to supply different boards.

The J13 jumper is used to connect the VIN supply from/to the CAN1 connector pin (J17 pin9). The J21 jumper is used to connect the VIN supply from/to the CAN2 connector pin (J8 pin9). The J16 jumper is used to connect the VIN supply from/to the LIN1 connector pin (J14 pin3). The J7 jumper is used to connect the VIN supply from/to the LIN2 connector pin (J5 pin3).

Both the LIN circuits (transceivers) work only with 12 V input. The CAN1 circuit/transceiver requires 12 V for VBAT and 5 V for VCC. CAN2 circuit/transceiver works when it is powered with 5 V.

**Warning:** Ensure extra care when providing the 12 V supply input to any of the J5, J8, J11, J12, J14 or J17 connectors. The supply should only be given to any one connector at a time.

### 3.6.2 Power LED

The Shield Kit has a power LED to indicate the 12 V input power supply.

Figure 3-10. Power LED Schematic

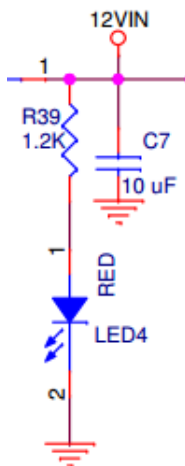

### 3.6.3 12 V-5 V DC-DC Conversion

#### 3.6.3.1 Regulator

A regulator (U2) is provided on the CAN and LIN shield board for 12 V to 5 V dc-dc conversion. The regulated 5 V is supplied to CAN transceivers, status LEDs and the baseboard (based on the J20 jumper selection). Figure 3-11 shows the 12 V-5 V regulator schematic.

Figure 3-11. 12 V-5 V Regulator Schematic

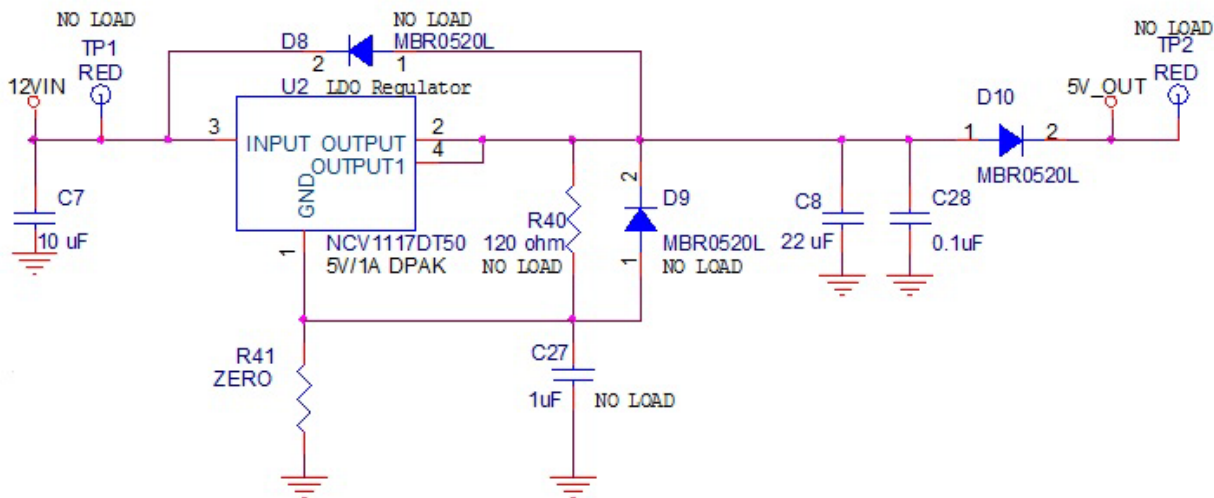

**Warning:** The regulator can support up to 1 A current, connecting this to any circuit which draws more than 1 A current will damage the regulator. Do not provide any power through the test points.

### 3.6.3.2 Cypress PMIC

An optional 12 V-5 V circuit is provided on the kit using a Cypress PMIC which is not populated. [Figure 3-12](#) shows the Cypress PMIC schematic.

Figure 3-12. Cypress PMIC Schematic

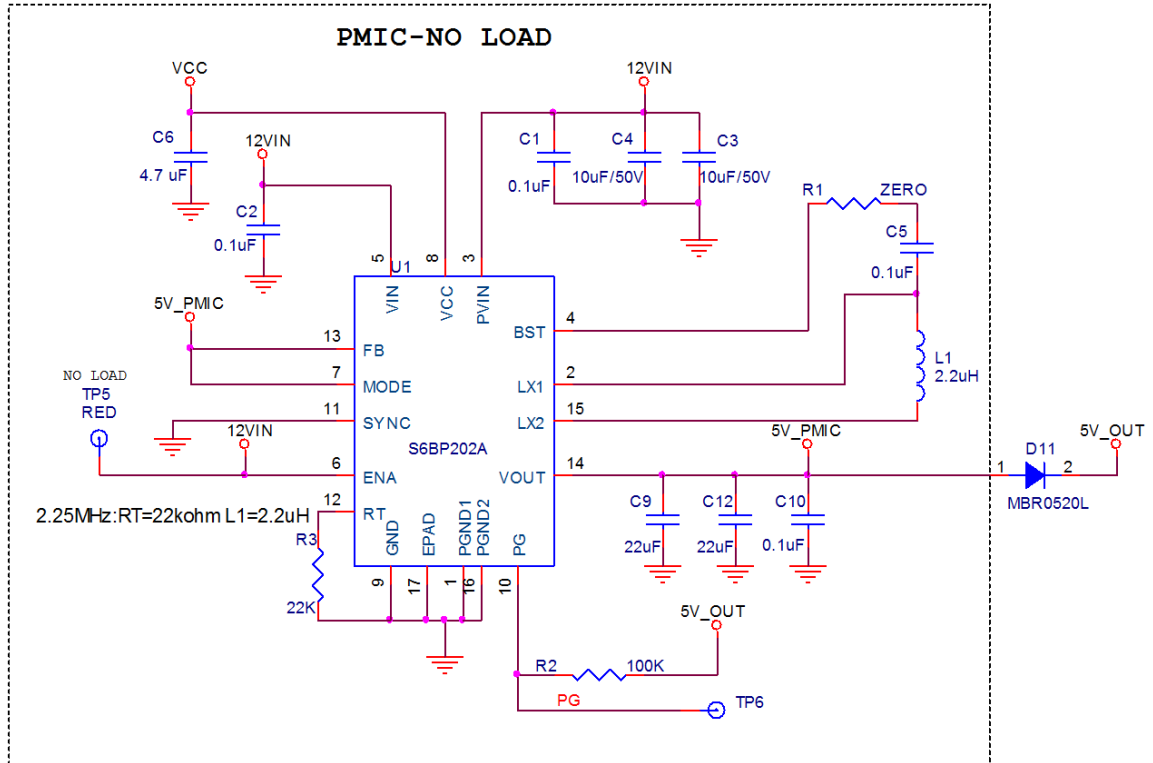

### 3.6.4 Power Selection Jumper (J20)

The power selection jumper is provided on this CAN and LIN Shield Kit to select different power supplies to power the shield board and the baseboard (CY8CKIT-042/044 or other Arduino compatible kits).

Figure 3-13. Jumper (J20) Schematic

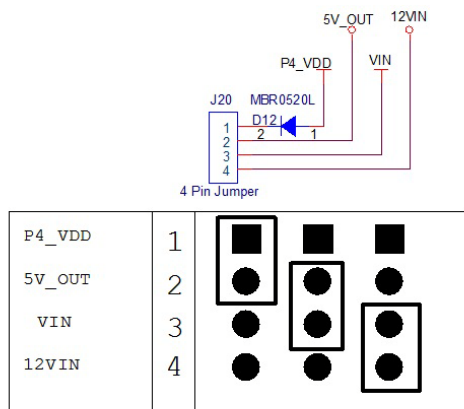

Short pins	Description
1&2	5V "Power to Shield" from Baseboard (provided by default)
* 2&3	5V "Power to Baseboard" from Shield
* 3&4	12V "Power to Baseboard" from Shield

\* During this selection do not connect any external supply to Baseboard through VIN pin.

The Shield Kit contains the following powering options:

1. Powering Shield Kit from the baseboard
 

To power the Shield Kit from the baseboard supply, short pin1 and pin2 of the J20 connector. This will provide 5 V to the shield and hence only CAN (CAN2 transceiver) communication is possible in this case. In order to supply 5 V to the Shield Kit, the baseboard has to be powered through 5 V USB and the power selection jumper on baseboard (J9 on CY8CKIT-042 and CY8CKIT-044) must be set at 5 V.
2. Powering baseboard from the Shield Kit
 

Following are the two options to power the baseboard from the Shield Kit supply:

  - a. Short pin 2 and 3 of the J20 connector to power the baseboard with 5 V from the shield kit regulator. This is supplied to the baseboard via Arduino header J1 pin 1.
  - b. Short pin 3 and 4 of the J20 connector to power the baseboard with 12 V via J1 pin 1. In this case, the regulator on the baseboard will convert 12 V to the appropriate voltage for the kit i.e., 3.3 V.

In both the above cases (options a and b), the baseboard power selection jumper (J9 on CY8CKIT-042 and CY8CKIT-044) should be at 3.3 V (only when USB is not connected to the baseboard).

Table 3-8. Powering Options with Jumper (J20)

J20 Connection	Power Option	Expected Function	Baseboard Requirement
Short pin 1 and 2	Power Shield Kit using the baseboard with 5 V	Only CAN (CAN2 transceiver circuit) communication is possible	Baseboard power selection jumper (J9 on CY8CKIT-042/044) must be at 5 V.
Short pin 2 and 3	Power baseboard using Shield Kit with 5 V	CAN and LIN communications are possible	Baseboard power selection jumper (J9 on CY8CKIT-042/044) should be at 3.3 V (only if USB is not connected to the baseboard).
Short pin 3 and 4	Power baseboard using Shield Kit with 12 V	CAN and LIN communications are possible	Baseboard power selection jumper (J9 on CY8CKIT-042/044) should be at 3.3 V (only if USB is not connected to the baseboard).

**Caution:** Ensure extra care when providing the supply to the baseboard from the Shield Kit. These jumpers should only be shorted (pin 2 and 3, or pin 3 and 4 of J20 connector) when there is no input supply given on the VIN pin of the baseboard.

## 4. Kit Operation



This chapter explains how to set-up the hardware connections in order to establish CAN and LIN communication using CY8CKIT-026.

### 4.1 Default Jumper Settings on CY8CKIT-026

Table 4-1 shows the default jumper settings of the CY8CKIT-026 CAN and LIN Shield Kit.

Table 4-1. Default Settings of the CY8CKIT-026 CAN and LIN Shield Kit

Jumper	Default Condition	Function
J7	Populated	Provides 12 V power from LIN2 connector
J10	Populated	Enables CAN2 termination resistor
J13	Not populated	Provides 12 V power from CAN1 connector
J16	Populated	Provides 12 V power from LIN1 connector
J20	Populated between pin 1 and 2	Provides Power selection options
J21	Not populated	Provides 12 V power from CAN2 connector

### 4.2 CAN Communication Hardware Setup

1. Connect the CAN and LIN Shield Kit to the Arduino header of a CY8CKIT-044 Pioneer Kit, as shown in [Figure 1-2](#).
2. Connect a second CAN and LIN Shield Kit to the Arduino header of a second CY8CKIT-044 Pioneer Kit, as shown in [Figure 1-2](#).
3. On both the CAN and LIN Shield Kits, connect the CAN TX and RX pins of the controller (Comes from the baseboard via the Arduino header) to CANx\_TX and CANx\_RX pins (on J19 connector for CAN1 transceiver, J9 connector of CAN2 transceiver) of the CAN transceiver circuit using connecting wires. See [CAN Signal Connector for CAN1 Transceiver on page 19](#) and [CAN Signal Connector for CAN2 Transceiver on page 19](#) for details of CAN TX and RX pin connections. See the [Example Projects on page 37](#) for the specific pin connections used in the example projects.  
**Note:** PSoC 4M supports two CAN modules. The supported CAN pins are:
  - a. P0[0] and P0[1] or P4[5] and P4[6] act as CAN\_Rx and CAN\_Tx for CAN1 module
  - b. P4[0] and P4[1] or P6[1] and P6[2] act as CAN\_Rx and CAN\_Tx for CAN2 module
4. Connect the two CAN and LIN Shield Kits together with a male-to-male, 9-pin, RS-232 cable with “straight-through” connections. Connect the DB9 cable to the corresponding CAN transceiver circuit DB9 connector (J17 for CAN1 transceiver and J8 for CAN2 transceiver) on both the shield kits.

Figure 4-1 shows connecting two CAN and LIN Shield kits through a DB9 cable. In this figure, the kit on the left is using CAN1 while the kit on the right is using CAN2. The other transceivers may also be used by changing the jumper wire connections and DB9 connector used.

Table 4-2 shows the connection details for CAN1 and CAN2 transceivers.

Table 4-2. Arduino Header Connection to CAN Transceivers

Arduino Pin	CAN1 Transceiver	CAN2 Transceiver
J2_13	J19_2 (CAN1_RX)	J9_3(CAN2_RX)
J2_15	J19_1 (CAN1_TX)	J9_2 (CAN2_TX)

Figure 4-1. Connected CAN and LIN Shield Boards

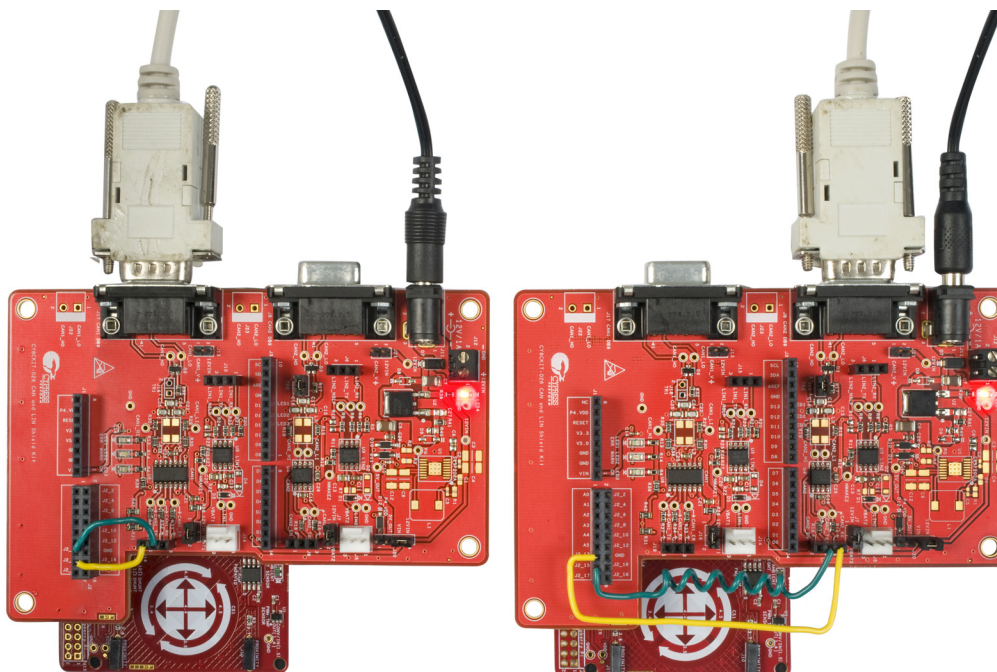

**Note:** If CAN1 is used on one kit and CAN2 is used on another kit, J10 should be removed on the kit which uses CAN2.

5. Power up both the Shield Kits using any one of the supply options as explained in 3.6.4 Power Selection Jumper (J20). In Figure 4-1, both the Shield Kits are powered up with different 12 V supplies.

### 4.3 Using CAN Bus Analyzer Tool

This kit functions most effectively when two CY8CKIT-44 PSoC 4M Pioneer Kits and two CY8CKIT-026 Shield Kits are available. However, it is also possible to replace one CY8CKIT-044 Pioneer Kit and one CY8CKIT-026 Shield Kit with a CAN bus analyzer or emulator tool. It is even possible to use any other CAN node to communicate with this kit.

Figure 4-2 and Figure 4-3 show connecting a CAN Bus analyzer to the Shield Kit.

Figure 4-2. CAN Analyzer Connection to CY8CKIT-026's CAN1 Transceiver





Figure 4-3. CAN Analyzer Connection to CY8CKIT-026's CAN2 Transceiver

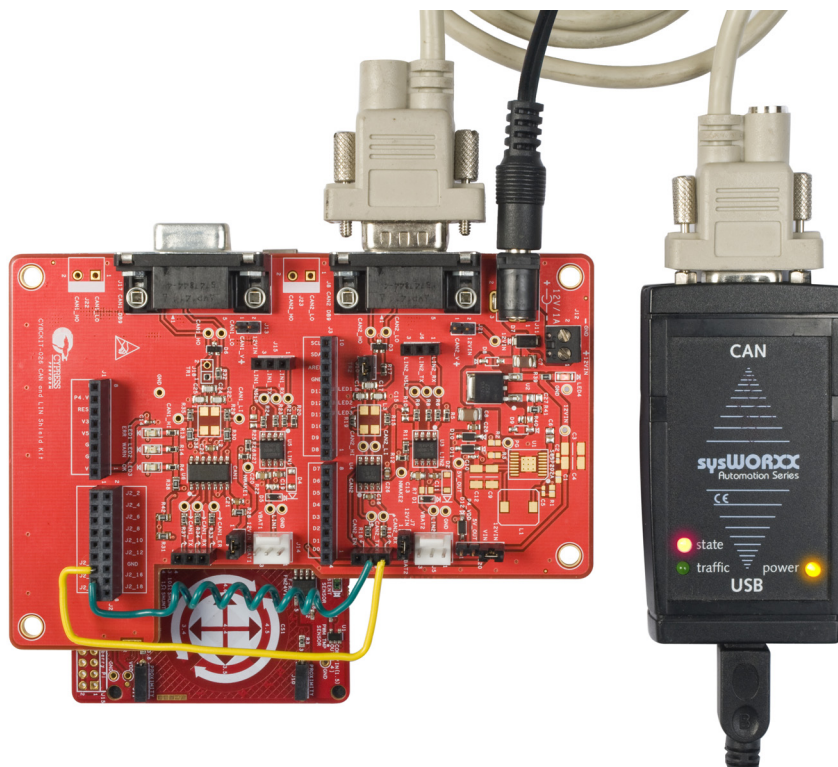

If you use a CAN bus analyzer or emulator tool to communicate with this kit, then the tool must be set up to send and receive CAN messages (at proper intervals) with proper length and message ID and at a proper baud rate.

If you use any other CAN node to communicate with this kit, then you may need to modify the firmware to allow communication. You can modify the code examples, firmware, or settings of the other CAN node. See the [Example Projects chapter on page 37](#) for more details on the CAN controller hardware configurations of this kit's code examples.

## 4.4 LIN Communication Hardware Setup

1. Connect the CAN and LIN Shield Kit to the Arduino header of the CY8CKIT-044/042 Pioneer Kit, as shown in [Figure 1-2](#).
2. Connect the LIN TX, LIN RX pins and Enable/sleep control pin (GPIO) of the controller (comes from the baseboard via the Arduino header) to LIN<sub>x</sub>\_TX, LIN<sub>x</sub>\_RX and LIN<sub>x</sub>\_NSLP pins (on J15 connector for LIN1 transceiver, J6 connector of LIN2 transceiver) of the LIN transceiver circuit using connecting wires.

[Table 4-3](#) shows how to connect the Arduino pins to the LIN<sub>x</sub> transceiver using wires.

Table 4-3. Arduino Header Connection to LIN Transceivers

Arduino Pin	LIN1 Transceiver	LIN2 Transceiver
J3_10 (SCL)	J15_1 (LIN1_RX)	J6_1 (LIN2_RX)
J3_9 (SDA)	J15_2 (LIN1_TX)	J6_2 (LIN2_TX)
J2_13	J15_3 (LIN1_NSLP)	J6_3 (LIN2_NSLP)

These connection are only if you are using P4.0 and P4.1 as LIN pins on the microcontroller. If you are using different pins for LIN, the corresponding pin connections on the Arduino header must be changed.

3. Connect VBAT, LIN bus, and GND of the LIN analyzer/LIN master to either J14 connector for LIN1 transceiver circuit or J5 connector for LIN2 transceiver circuit of Shield Kit, as shown in [Figure 4-4](#). See [LIN Bus Connectors on page 20](#) for details of LIN bus connectors.

Figure 4-4. Connect to LIN Bus Connector

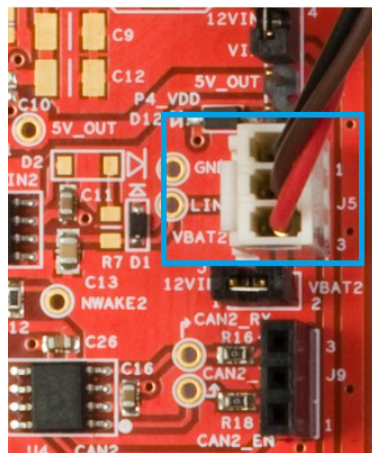

4. Connect a 12 V power supply input to the Shield Kit using any of the supply option described in [12 V Supply Input on page 25](#), and power the baseboard by populating the power selection jumper explained in [Power Selection Jumper \(J20\) on page 28](#).

## 4.5 Using LIN Bus Analyzer Tool

The LIN code example projects demonstrate functionality of the LIN slave device, so a LIN master device must be used. A LIN bus analyzer or emulator tool can be used as the LIN master device. It is also possible to use any other LIN master node to communicate with this example project. If you use a LIN bus analyzer or emulator tool, then the tool must be set up to send and receive frames with proper length and ID and at a proper baud rate. See the [Example Projects chapter on page 37](#) for the specific pin connections used in the LIN example projects.

[Figure 4-5](#) and [Figure 4-6](#) show connecting a LIN Bus analyzer to the Shield Kit.

Figure 4-5. LIN Analyzer Connection to CY8CKIT-026's LIN1 Transceiver

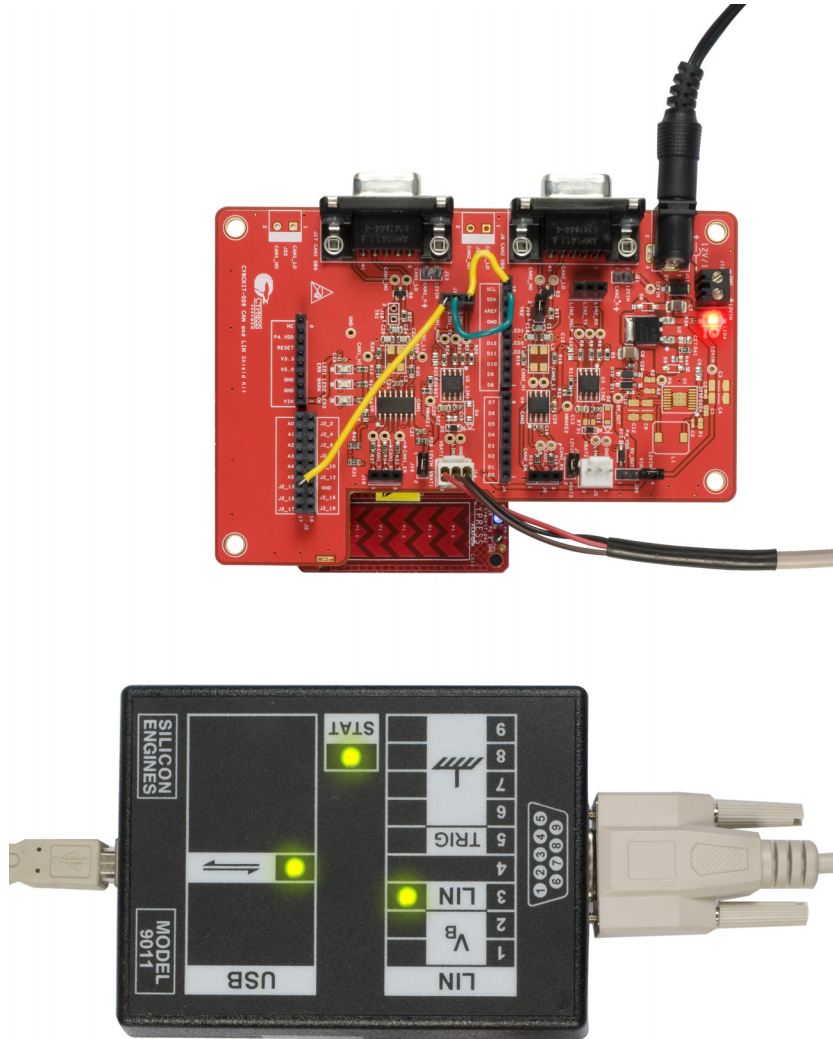
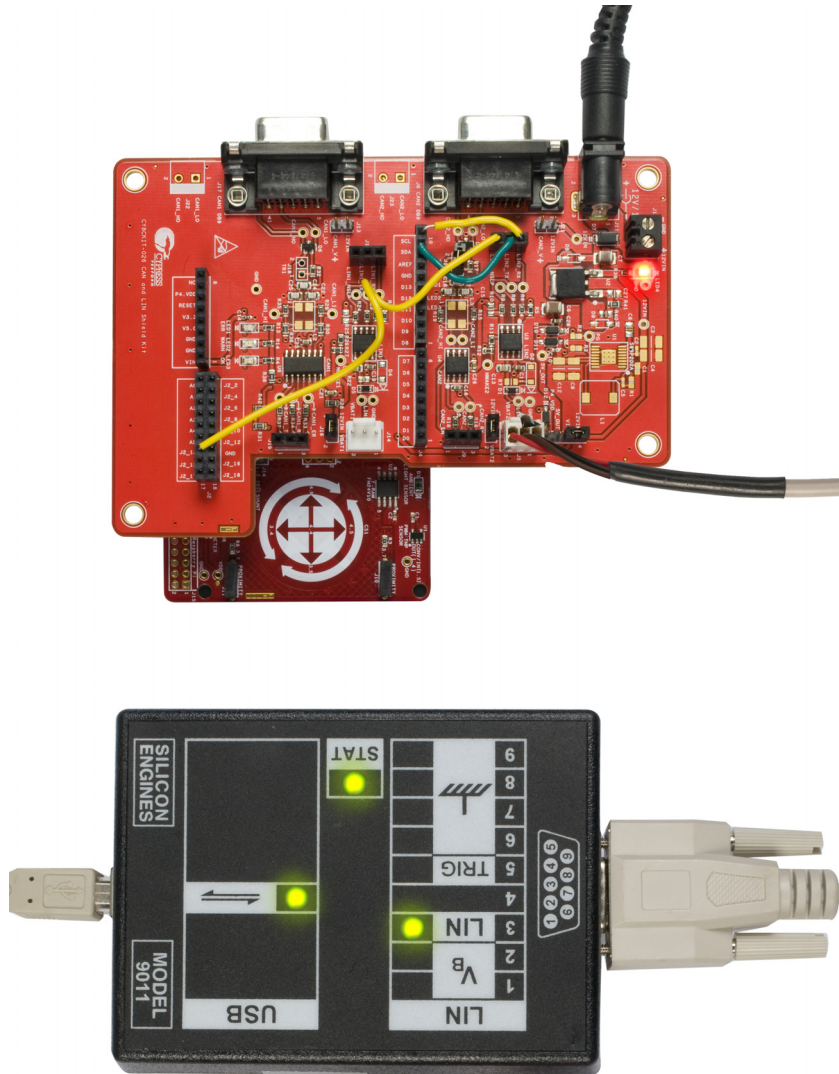

Figure 4-6. LIN Analyzer Connection to CY8CKIT-026's LIN2 Transceiver



# 5. Example Projects



The CY8CKIT-026 CAN and LIN Shield Kit includes five example projects. This chapter explains how to use these example projects. To access the example projects, download and install the CY8CKIT-026 CAN and LIN Shield Kit setup file from [www.cypress.com/CY8CKIT-026](http://www.cypress.com/CY8CKIT-026). After installation, the kit example projects will be available in the Firmware folder in the installation location.

## 5.1 Using the Kit Example Projects

Perform these steps to open and use the example projects:

1. Launch PSoC Creator from **Start > All Programs > Cypress > PSoC Creator <version> > PSoC Creator <version>**.
2. On the Start page, expand **CY8CKIT-026 CAN and LIN Shield Kit** under **Examples and Kits > Kits**. A list of example projects appears, as shown in [Figure 5-1](#).
3. Click on the desired example project, select a location to save the project and click **OK**.

Figure 5-1. Open Example Project from PSoC Creator

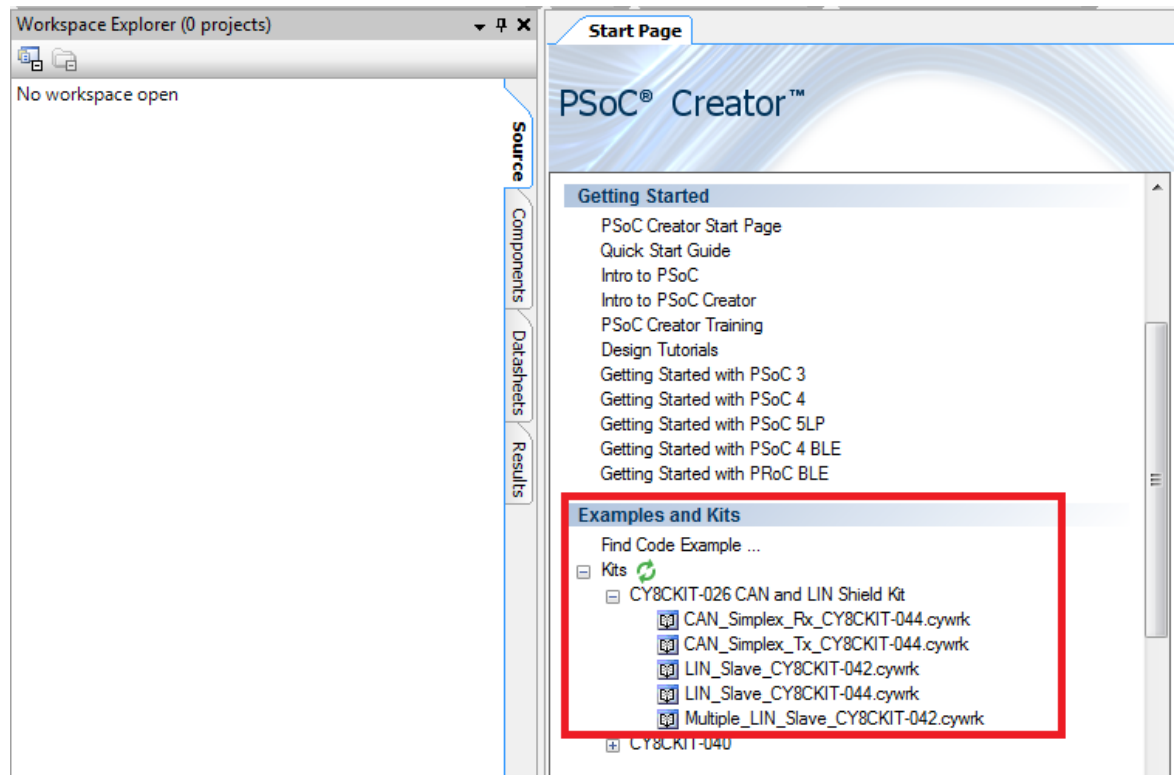

4. Build the example project by choosing **Build > Build <Project Name>**. A *.hex* file is generated after successful build process.
5. Connect the corresponding baseboard to the PC using the USB cable to program the kit with this example project.
6. Choose **Debug > Program** in PSoC Creator.

## 5.2 CAN\_Simplex\_Tx\_CY8CKIT-044

### 5.2.1 Project Description

This project explains how to transmit data over the CAN bus. The device is configured as a CAN transmitter which transmits the data whenever the CapSense gesture pad is touched. When the CapSense gesture pad center button is pressed, then the blue LED on the baseboard (CY8CKIT-044) toggles (ON/OFF) and the CAN data byte1 also toggles between 0 and 1. If the left/right buttons of the gesture pad are pressed, then the CAN data byte2 toggles between 0, 1 and 2. If the up/down gesture pad is pressed, then the byte3 of the CAN data increases/decreases by 30 counts respectively.

### 5.2.2 Hardware Connections

1. Plug-in the CY8CKIT-026 kit to the CY8CKIT-044 through Arduino connector.
2. Since there are two CAN transceivers on the CY8CKIT-026, choose to use one of the CAN transceivers (U6 - CAN1 and U4 - CAN2). Connect J2\_13 and J2\_15 to the appropriate CANx\_Rx and CANx\_Tx pins of the transceiver connector (J19 - CAN1 or J9 - CAN2), as provided in [Table 5-1](#).

Table 5-1. Pin Connection on CY8CKIT-026

Arduino Header Pins	CAN1 Transceiver	CAN2 Transceiver
J2_13	J19_2 (CAN1_RX)	J9_3 (CAN2_RX)
J2_15	J19_1 (CAN1_TX)	J9_2 (CAN2_TX)

3. CAN2 transceiver works with 5 V, whereas CAN1 transceiver requires 12 V input supply.
4. If you have chosen CAN1 transceiver, then external 12 V supply has to be connected through J11, J12, or J17. Refer to [Power Supply Configurations on page 24](#) for more details on power supply connections.
5. If you have chosen CAN2 transceiver, you can use external 12 V supply which will be converted to 5 V with the on board regulator, or you can power the CAN2 transceiver with the baseboard (CY8CKIT-044) by shorting pin 1 and 2 of the power selection jumper (J20).
6. When you are powering the CY8CKIT-026 with the baseboard with 5 V, ensure that the jumper J9 on the baseboard (CY8CKIT-044) is in the 5 V position. When you are using 12 V external supply and powering the baseboard from the Shield Kit (without a USB connection), ensure that the jumper J9 on the baseboard (CY8CKIT-044) is in the 3.3 V position. Refer to [Power Selection Jumper \(J20\) on page 28](#) for more details.
7. Connect the CAN analyzer to the appropriate transceiver using a DB9 male to female connector as shown in [Figure 4-2](#) or [Figure 4-3](#) for receiving the transmitted data.
8. You can also use another CY8CKIT-044 and CY8CKIT-026 setup instead of a CAN analyzer as shown in [Figure 4-1](#), which should be programmed with the CAN\_Simplex\_Rx\_CY8CKIT-044 project (see [CAN\\_Simplex\\_Rx\\_CY8CKIT-044 on page 41](#)) to receive this transmitted data.

### 5.2.3 Verify Output

To verify the CAN\_Simplex\_Tx\_CY8CKIT-044 example project, perform these steps:

1. Program the CY8CKIT-044 PSoC 4 M-Series Pioneer Kit with CAN\_Simplex\_Tx\_CY8CKIT-044 code example through USB connector J6.
2. Ensure that the power supply and jumper settings are proper, as explained in the [Hardware Connections on page 38](#).
3. Perform these steps if you are using any CAN analyzer for receiving the data:
  - a. Install the appropriate software of the CAN analyzer.
  - b. Open the CAN analyzer software and set the Baud rate to 125 Kbps.
  - c. Touch the CapSense gesture pad buttons (Center/Right/Left/Up/Down) and observe the data on CAN analyzer software, as provided in [Table 5-2](#).

Table 5-2. CapSense Gesture Pad Data to CAN Analyzer

CapSense Gesture Pad Button	Data on CAN Analyzer
Center Button	Byte1 toggles b/w 0 and 1 (1 → ON, 0 → OFF)
Right Button <sup>1</sup>	Byte2 changes as 0 → 1 → 2 → 0...
Left Button <sup>1</sup>	Byte2 changes as 2 → 1 → 0 → 2...
Up Button <sup>1</sup>	Byte3 increases by 30 counts
Down Button <sup>1</sup>	Byte3 decreases by 30 counts

1. Pressing these buttons transmits the CAN data only when the Byte1 is '1' (i.e., center button is ON). If Byte1 is '0' (i.e., center button is OFF), pressing these buttons does not have any effect.

- d. The Sys Tec CAN analyzer is used as an example for this project. Data can be observed, as shown in [Figure 5-2](#).

Figure 5-2. CAN Data received on CAN Analyzer Software as Receiver

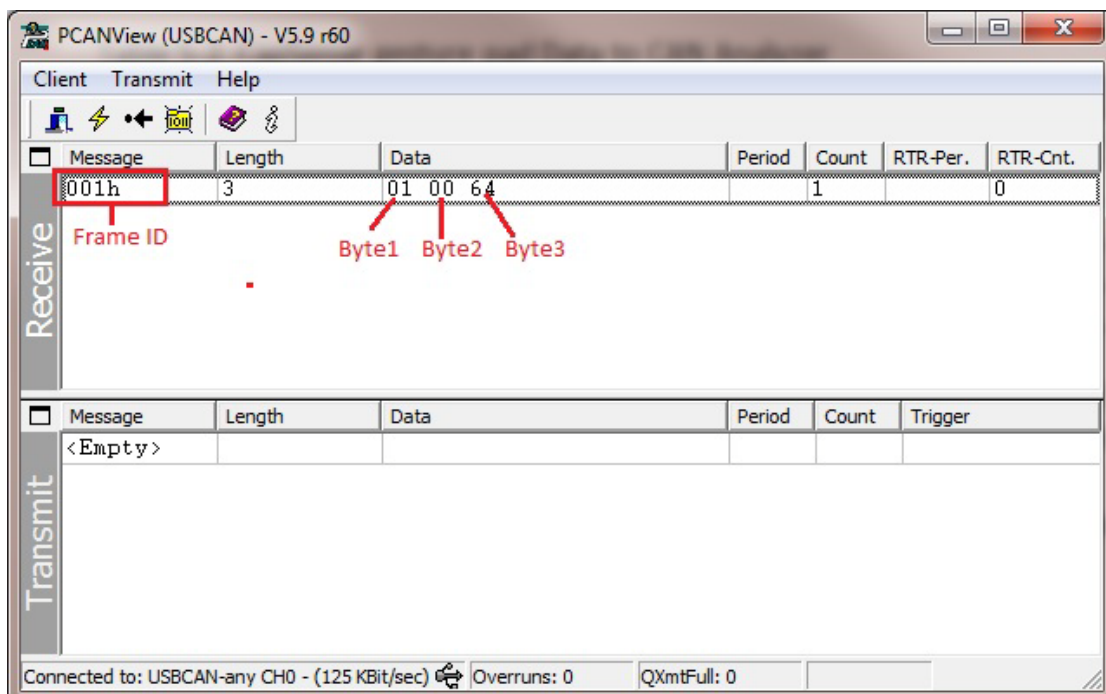

4. Perform these steps, if you are using another set of CY8CKIT-044 and CY8CKIT-026 for receiving the data:
  - a. Program the second baseboard with the *CAN\_Simplex\_Rx\_CY8CKIT-044.hex* file and set the hardware connections provided in [Hardware Connections on page 41](#).
  - b. Connect both the Shield Kits with a DB9 male-to-male connector, as shown in [Figure 4-1](#) and switch ON the power supply for both the kits.
  - c. Touch the CapSense gesture pad buttons on the first baseboard (that is programmed with CAN\_Simplex\_Tx\_CY8CKIT-044 project). Observe the Color and Brightness of the RGB LED on the second board, as provided in [Table 5-3](#).

Table 5-3. Controls the RGB LED on Second Board using CapSense Gesture Pad

CapSense Gesture Pad Button	RGB LED on Second Kit (CY8CKIT-044)
Center Button	RGB LED ON
Right Button	LED switches the color as R → G → B → R...
Left Button	LED switches the color as B → G → R → B...
Up Button	LED brightness increases
Down Button	LED brightness decreases

5. To observe the data that is transmitted through CAN bus using UART, connect the baseboard to a PC using a USB cable, and then perform these steps:
  - a. Open any serial terminal software (Tera Term software is shown here as an example).
  - b. After selecting appropriate COM port (For example COM37 in [Figure 5-3](#)), set the Baud rate to 115200, Parity = none, Stop bit = 1, as shown in [Figure 5-3](#).

Figure 5-3. Serial Terminal Settings

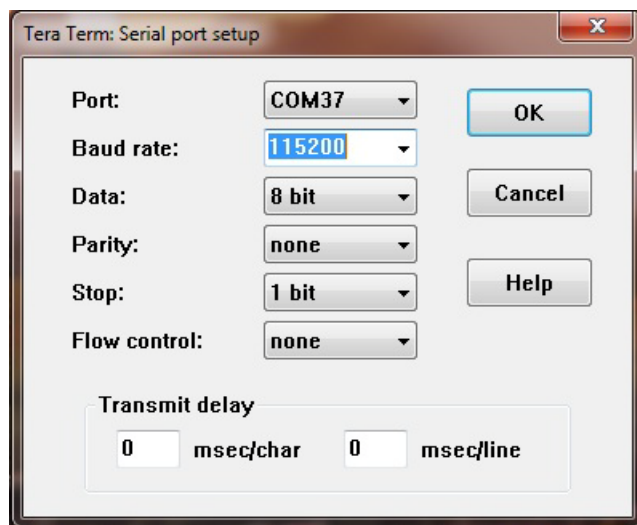



- c. While pressing the CapSense gesture pad buttons, observe the data on the UART serial terminal software, as shown in [Figure 5-4](#).

Figure 5-4. Transmitter UART Data on Serial Terminal

```
onOffStatus: 0    color:2    brightness:10
onOffStatus: 1    color:2    brightness:10
onOffStatus: 1    color:0    brightness:10
onOffStatus: 1    color:1    brightness:10
onOffStatus: 1    color:1    brightness:40
onOffStatus: 1    color:1    brightness:70
onOffStatus: 0    color:1    brightness:70
```

**Note:** For more details on the project, i.e., how to configure the CAN component, CapSense component, IMO trimming, pin configurations, and so on, refer to Code Example [CE97311](#).

## 5.3 CAN\_Simplex\_Rx\_CY8CKIT-044

### 5.3.1 Project Description

This project receives data sent from the CAN bus with pre-defined frame ID as 0x01. The first 3-bytes of the received data will control the RGB LED status, color and brightness. If the first byte is '0', the RGB LED will be OFF and when it is '1', the RGB LED switches ON. The second data byte has values as 0, 1 or 2, then the red, green or blue LED turns ON correspondingly. The 3rd data byte value controls the RGB LED brightness.

### 5.3.2 Hardware Connections

1. Plug-in the CY8CKIT-026 kit to the CY8CKIT-044 through Arduino connector.
2. Since there are two CAN transceivers on the CY8CKIT-026, choose one of the CAN transceivers (U6 - CAN1 and U4 - CAN2). Connect J2\_13 and J2\_15 to the appropriate CANx\_Rx and CANx\_Tx pins of the transceiver connector (J19 - CAN1 or J9 - CAN2), as provided in [Table 5-4](#).

Table 5-4. Pin Connection on CY8CKIT-026

Arduino Header Pins	CAN1 Transceiver	CAN2 Transceiver
J2_13	J19_2 (CAN1_RX)	J9_3 (CAN2_RX)
J2_15	J19_1 (CAN1_TX)	J9_2 (CAN2_TX)

3. CAN2 transceiver works with 5 V and CAN1 transceiver requires 12 V input supply.
4. If you have chosen CAN1 transceiver, then external 12 V supply has to be connected through J11, J12, or J17. Refer to the [Power Supply Configurations on page 24](#) for more details on power supply connections.
5. If you have chosen the CAN2 transceiver, you can use external 12 V supply which will be converted to 5 V with the on board regulator, or you can power the CAN2 transceiver with the baseboard (CY8CKIT-044) by shorting pin 1 and 2 of the power selection jumper (J20).
6. When you are powering the CY8CKIT-026 from the baseboard with 5 V, ensure that the jumper J9 on the baseboard (CY8CKIT-044) is set to the 5 V position. When you are using 12 V external supply and powering the baseboard from the Shield Kit (without a USB connection), ensure that the jumper J9 on the baseboard (CY8CKIT-044) is set to the 3.3 V selection. Refer to [Power Selection Jumper \(J20\) on page 28](#) for more details.

7. Connect the CAN analyzer to the appropriate transceiver using a DB9 male to female connector, as shown in [Figure 4-2](#) or [Figure 4-3](#) for receiving the transmitted data.
8. You can also use another CY8CKIT-044 and CY8CKIT-026 setup instead of a CAN analyzer, as shown in [Figure 4-1](#), which should be programmed with the CAN\_Simplex\_Tx\_CY8CKIT-044 project (described above) to transmit data over CAN.

### 5.3.3 Verify Output

To verify the CAN\_Simplex\_Rx\_CY8CKIT-044 code example, perform these steps:

1. Program the CY8CKIT-044 PSoC 4 M-Series Pioneer Kit with CAN\_Simplex\_Rx\_CY8CKIT-044 code example through USB connector J6.
2. Make sure that the power supply and jumper settings are proper as explained in the [Hardware Connections on page 41](#).
3. Perform these steps if you are using any CAN analyzer for receiving the data:
  - a. Install the appropriate software of the CAN analyzer.
  - b. Open the CAN analyzer software and set the Baud rate to 125 Kbps.
  - c. Add a new transmit frame as, Frame ID = 0x01, Data Length Code (DLC) ≥ 3, and add data bytes values as provided in [Table 5-5](#).

Table 5-5. RGB LED Status with respect to CAN Data Bytes

Data Bytes		RGB LED Status on CY8CKIT-044
Byte Number	Value	
Byte '1'	0	LED OFF
	1	LED ON
Byte '2'	0 <sup>1</sup>	Red LED ON
	1 <sup>1</sup>	Green LED ON
	2 <sup>1</sup>	Blue LED ON
Byte '3'	0 to 255 <sup>1</sup>	Controls the brightness of the LED

1. Transmitting these values changes the RGB LED color and brightness only when the first data byte is equal to '1'. If the Byte1 is '0', sending these values doesn't have any effect on the RGB LED status & brightness

- d. The Sys Tec CAN analyzer is used for this example project. To add the transmit message, go to **Transmit > New**. A New Transmit message window will appear. Enter the message details, as shown in [Figure 5-5](#).

Figure 5-5. Sys Tech CAN Analyzer Frame ID Settings

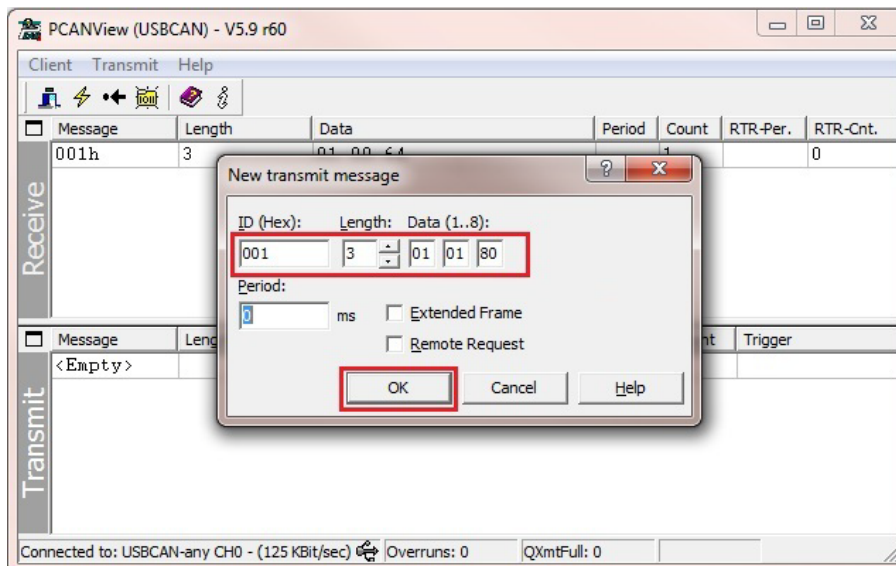

- e. Double-click on frame ID in the Transmit window. This will transmit the CAN frame through the bus.
  - f. Once the message is transmitted, then the count value on the analyzer software increases by '1'. Else, the frame is not transmitted. Check the hardware connections and retransmit the message.
  - g. Once the frame is transmitted, observe the RGB LED status on the baseboard as explained in [Table 5-5](#). Additional transmit messages may be added to change the LED state, color, or brightness.
  - h. If an error is displayed on the CAN analyzer software after transmitting the frame, reset the Kit-044 once and try transmitting the frame.
4. Perform these steps if you are using another set of CY8CKIT-044 and CY8CKIT-026 for receiving the data:
    - a. Program the second baseboard with the CAN\_Simplex\_Tx\_CY8CKIT-044.hex file and make the hardware connections as shown in [Hardware Connections on page 38](#).
    - b. Connect both the Shield Kits with a DB9 male-to-male connector as shown in [Figure 4-1](#) and switch ON the power supply for both the kits.

- c. Touch the CapSense gesture pad buttons on the second baseboard (that is programmed with CAN\_Simplex\_Tx\_CY8CKIT-044 project). Observe the Color and Brightness of the RGB LED on the second board, as provided in [Table 5-6](#).

Table 5-6. RGB LED Status Based on CapSense Gesture Pad

CapSense Gesture Pad Button	RGB LED on First Kit (CY8CKIT-044)
Center Button	RGB LED ON
Right Button	LED switches the color as R → G → B → R...
Left Button	LED switches the color as B → G → R → B...
Up Button	LED brightness increases
Down Button	LED brightness decreases

- 5. To observe the data received through CAN bus using UART, connect the baseboard to the PC through USB cable and perform these steps:
  - a. Open any serial terminal software (Tera Term software is used as an example here).
  - b. After selecting appropriate COM port (For example COM37 in [Figure 5-3](#)), set the Baud rate to 115200, Parity = none, Stop bit = 1, as shown in [Figure 5-3](#).
  - c. Whenever you receive data over CAN bus, you can observe the data on UART serial terminal software, as shown in [Figure 5-6](#).

Figure 5-6. Receiver UART Data on Serial Terminal

```
onOffStatus: 0   color:2   brightness:10
onOffStatus: 1   color:2   brightness:10
onOffStatus: 1   color:0   brightness:10
onOffStatus: 1   color:1   brightness:10
onOffStatus: 1   color:1   brightness:40
onOffStatus: 1   color:1   brightness:70
onOffStatus: 0   color:1   brightness:70
```

**Note:** For more details on the project that is used to configure the CAN component, CapSense component, IMO trimming, pin configurations, and so on refer to Code Example [CE97311](#).

## 5.4 LIN\_Slave\_CY8CKIT-042

### 5.4.1 Project Description

In this example, PSoC 4200 (CY8CKIT-042) acts as a simple LIN slave. The slave monitors data that is transmitted from the LIN master (analyzer). If a predefined frame is received from the master, the slave controls the RGB LED color according to the data available in the received frame. The LIN master can get the RGB LED status by sending a frame with a predefined frame ID.

### 5.4.2 Hardware Connections

1. Plug-in the CY8CKIT-026 kit to the CY8CKIT-042 using the Arduino connectors.
2. Since there are two LIN transceivers on the CY8CKIT-026, choose either of the transceivers to use (U5 - LIN1 transceiver or U3 - LIN2 transceiver). Connect the Arduino header pins (which are connected to the baseboard controller) to the appropriate LIN transceiver using jumper wires, as provided in [Table 5-7](#).

Table 5-7. Pin Connection on CY8CKIT-026

Arduino Header Pins	LIN1 Transceiver	LIN2 Transceiver
J3_10 (SCL)	J15_1 (LIN1_RX)	J6_1 (LIN2_RX)
J3_9 (SDA)	J15_2 (LIN1_TX)	J6_2 (LIN2_TX)
J2_13	J15_3 (LIN1_NSLP)	J6_3 (LIN2_NSLP)

3. Connect the LIN analyzer to the J14 connector to use LIN1 transceiver or J5 connector to use LIN2 transceiver
4. If the LIN analyzer **DOES** provide 12 V supply through the VBAT pin then you can power the board with that supply without using any additional 12 V supply since the corresponding jumper (J16 for LIN1 & J7 for LIN2) are populated by default.
5. You need to connect a 12 V supply input to the board through J11 power jack or J12 screw terminal connector, if the analyzer **DOES NOT** provides 12 V supply.

**Caution:** Ensure extra care when the LIN analyzer provides 12 V through the VBAT pin and connecting it to any of the connectors J14 and J5 and also using a 12 V external supply. Since the jumpers J16 and J7 are populated (by default); it will short the VIN supply rail to the VBAT pin of the LIN connector. In that case, either remove the external 12 V supply or remove the corresponding jumper (J16 or J7). Otherwise, the Shield Kit, Baseboard and supply adapter could be damaged.

6. The baseboard (CY8CKIT-042) can be powered using USB or it can be powered from the Shield kit by selecting jumper J20 appropriately. Refer to the [Power Selection Jumper \(J20\) on page 28](#) for more details on power connection options.

### 5.4.3 Verify Output

To verify the LIN\_Slave\_CY8CKIT-042 code example, perform these steps.

Silicon Engines LIN/USB Data Converter is used as LIN analyzer in this example.

1. Program the CY8CKIT-042 PSoC 4 Pioneer Kit with LIN\_Slave\_CY8CKIT-042 example project through USB connector J10.
2. Ensure that the power supply and jumper settings are as explained in [5.4.2 Hardware Connections](#).
3. Install the 'SE9004 and 9011 LINUSB Message Center software (provided by Silicon Engines) on your PC and connect the LIN analyzer to PC through USB cable. If a different analyzer is being used, install the appropriate software.
4. Open the LIN analyzer software and go to **Configure LIN/USB**. Configure LIN Box Interface window is displayed. Set the **LIN Bus Baud Rate** to 19200 bps, and then select the **LIN 2.0-2.1 Protocol** checkbox, as shown in [Figure 5-7](#).

Figure 5-7. LIN Analyzer Configurations

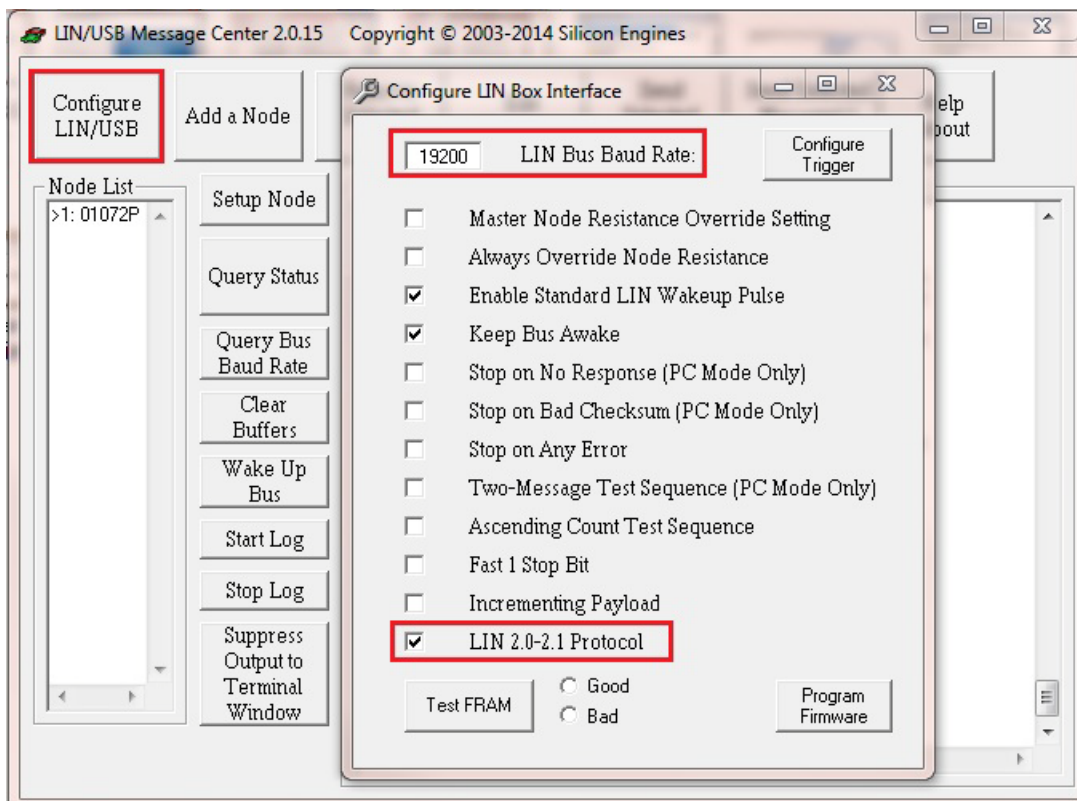

5. If you are using any other analyzer, make sure that the checksum setting is selected as enhanced checksum since LIN v2.1/2.2 specification supports only enhanced checksum (this option is not required in Silicon Engines LIN-USB converter software).

6. Add the message in the analyzer in Figure 5-8. Note that the message must start with the ID.

Figure 5-8. Adding and Sending Message using LIN Analyzer

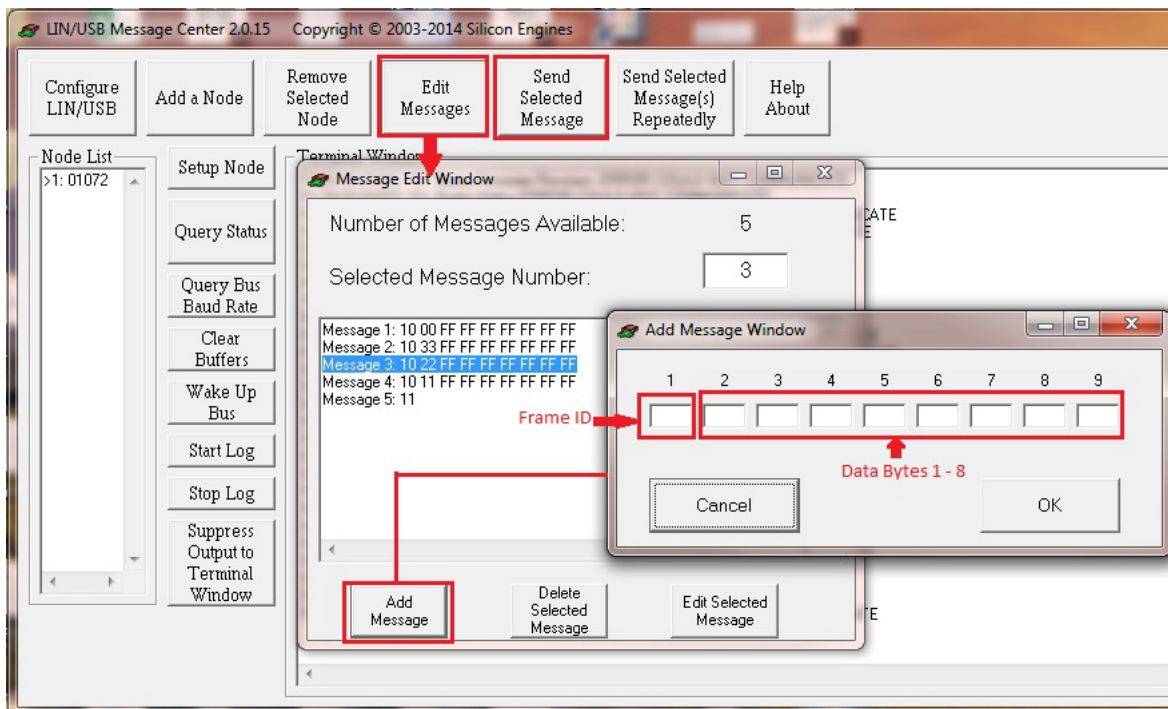

7. If a frame with ID = 0x10 is received from the master (analyzer), then the slave controls the RGB LED based on the received data command from master, as provided in Table 5-8. Note that the message must start with the ID and must contain eight data bytes even though only the first byte is used to control the LED. The other seven data bytes can be any value.

Table 5-8. Slave Response as per the Commands from Master

Command	Slave Response
0x11	Turns ON Red LED
0x22	Turns ON Green LED
0x33	Turns ON Blue LED
0x00	Turns OFF RGB LED

- If a frame with ID = 0x11 is received from the LIN Analyzer, then the slave will send the RGB LED status back to the master, as provided in [Table 5-9](#). The message in this case only needs the message ID. No data bytes are required.

Table 5-9. RGB LED Status

RGB LED Status	Data Byte
Red LED ON	0xAA
Green LED ON	0xBB
Blue LED ON	0xCC
RGB LED OFF	0xDD

- The result of transmitted and received data at the LIN analyzer end is shown in [Figure 5-9](#).

Figure 5-9. Results at LIN Analyzer

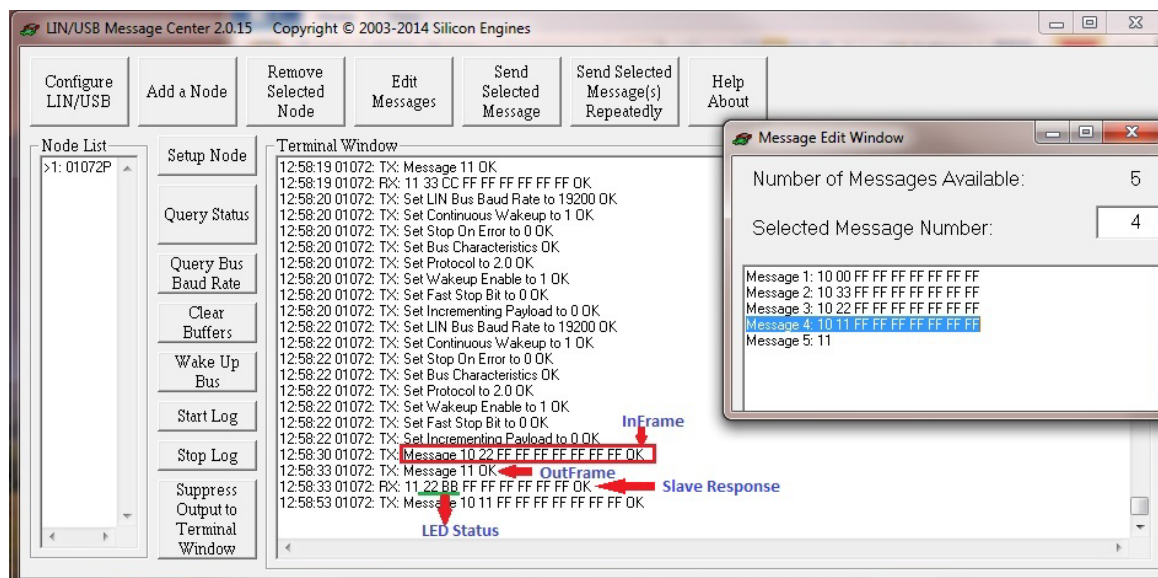

In this figure, InFrame refers to “10 22 FF FF FF FF FF FF” where 10 is the frame ID and 22, FF, FF, FF, FF, FF, FF, FF are the eight data bytes. Since, the 'InFrame' in LIN slave is configured with only 2 bytes named as InSig and InArraySig, the rest of the data bytes (3 to 8) are ignored by the slave. When the 'OutFrame' is received from the analyzer as marked in this figure, the slave responds to the frame with the RGB LED status along with frame ID as 11 22 BB where '11' is frame ID, '22' is the previous 'InFrame' data byte (command) and 'BB' is the RGB LED status (i.e., Green LED is ON).

**Note:** For more details on how to configure the LIN component, pin configurations, and so on refer to Code Example [CE96999](#).

**Note:** If there is an error message such as “BUS STUCK HIGH” or “TX FRAME ERROR”, reset the baseboard (CY8CKIT-042/44) and LIN analyzer.



## 5.5 LIN\_Slave\_CY8CKIT-044

### 5.5.1 Project Description

In this example, PSoC 4200 M (CY8CKIT-044) acts as a simple LIN slave. The slave monitors data that is transmitted from the LIN master (analyzer). If a predefined frame is received from the master, the slave controls the RGB LED color according to the data available in the received frame. The LIN master can get the RGB LED status by sending a frame with a predefined frame ID.

The example project LIN\_Slave\_CY8CKIT-044 is same as LIN\_Slave\_CY8CKIT-042 except the baseboard that is CY8CKIT-044 is used instead of CY8CKIT-042.

Follow the same steps for Hardware connections and verifying the output as specified in [5.4 LIN\\_Slave\\_CY8CKIT-042](#) and replace the baseboard from CY8CKIT-042 to CY8CKIT-044.

**Note:** For more details on how to configure the LIN component, pin configurations, and so on refer to Code Example [CE96999](#).

## 5.6 Multiple\_LIN\_Slave\_CY8CKIT-042

### 5.6.1 Project Description

In this example, PSoC 4 is initialized as two LIN slave nodes; each node is connected to a different LIN master. If a predefined frame is received from the LIN master1, the slave either stores or sends the CapSense linear slider centroid position to the master. If a predefined frame is received from the LIN master2, the slave either controls/changes the RGB LED or sends the RGB LED status to the master. LIN1 is configured as a v2.0/2.1 slave while LIN2 is configured as a v1.3 slave.

### 5.6.2 Hardware Connections

1. Plug-in the CY8CKIT-026 kit to the CY8CKIT-042 using the Arduino connectors.
2. Connect the Arduino header pins (which are connected to the baseboard controller) to the appropriate LIN transceiver through jumper wires, as provided in [Table 5-10](#).

Table 5-10. Pin Connection on CY8CKIT-026

Arduino Header Pins	LIN1 & LIN2 Connector Pins
J3_10	J15_1 (LIN1_RX)
J3_9	J15_2 (LIN1_TX)
J2_13	J15_3 (LIN1_NSLP)
D0	J6_1 (LIN2_RX)
D1	J6_2 (LIN2_TX)
J2_15	J6_3 (LIN2_NSLP)

3. Connect the LIN1 analyzer to the J14 connector and LIN2 analyzer to J5 connector on the CY8CKIT-026 Kit. Since there are two LIN slaves in this project, you need to have two LIN analyzers - each should connect to one LIN slave.
4. If either of the LIN analyzer **DOES** provide 12 V supply through VBAT pin then you can power the board with that supply without using any additional 12 V supply since the corresponding jumper (J16 for LIN1 and J7 for LIN2) are populated by default. Be careful to not power-up the shield kit with multiple supplies.

5. You need to connect a 12 V supply input to the board through J11 power jack or J12 screw terminal connector, if both the analyzers **DO NOT** provide 12 V supply.

**Caution:** Ensure extra care when either of the LIN analyzers provide 12 V through VBAT pin and connecting it to any of the connectors J14 and J5 and also using 12 V external supply. Since the jumpers J16 and J7 are populated (by default), it will short the VIN supply rail to the VBAT pin of the LIN connector. In that case, either remove the external 12 V supply or remove the corresponding jumper (J16 or J7). Otherwise, the Shield Kit, Baseboard and supply adapter could be damaged.

7. The baseboard (CY8CKIT-042) can be powered using USB or it can be powered from the Shield kit by selecting jumper J20 appropriately. Refer to the [Power Selection Jumper \(J20\) on page 28](#) for more details on power connection options.

### 5.6.3 Verify Output

To verify the Multiple\_LIN\_Slave\_CY8CKIT-042 example project, perform these steps:

In this example, the PSoC 4200 device is configured as two LIN slaves where each slave is connected to a different LIN network. You need two LIN analyzers to verify the output. Two [Silicon Engines LIN/USB Data Converter's](#) are used as LIN analyzers in this example.

1. Program the CY8CKIT-042 PSoC 4 Pioneer Kit with Multiple\_LIN\_Slave\_CY8CKIT-042 example project through USB connector J10.
2. Make sure that the power supply and jumper settings are proper as explained in the [Hardware Connections on page 49](#).
3. Install the 'SE9004 and 9011 LINUSB Message Center' software (if a different analyzer is being used, install the appropriate software) on your PC and connect the LIN analyzer to PC through USB cable.
4. Verifying the LIN slave1 output:
  - a. Open the LIN1 analyzer software and go to **Configure LIN/USB**, set the **LIN Bus Baud Rate** to 19200 bps, and then select the **LIN 2.0-2.1 Protocol** checkbox as shown in [Figure 5-7](#).
  - b. If you are using any other analyzer, make sure that the checksum setting is selected as enhanced checksum since LIN v2.1/2.2 specification supports only enhanced checksum (this option is not required in Silicon Engines LIN-USB converter software).
  - c. Add the message/frame in the analyzer software which needs to be transmitted to the slave and send it through the analyzer shown in [Figure 5-8](#).
  - d. Place your finger on the CapSense linear slider (on the CY8CKIT-042) and send a frame with ID = 0x10 and 8 data bytes. The first data byte should be 0x22. The other data bytes can be any value.
  - e. If a frame with ID = 0x10 with first data byte = 0x22 is received from LIN1 analyzer, then the slave will store the current CapSense linear slider centroid position.
  - f. If a frame with ID = 0x11 is received from the LIN1 analyzer, then the slave will send the stored CapSense linear slider centroid position back to the analyzer.

g. The result of transmitted and received data at the LIN1 analyzer is shown in [Figure 5-10](#).

Figure 5-10. Results at LIN1 analyzer

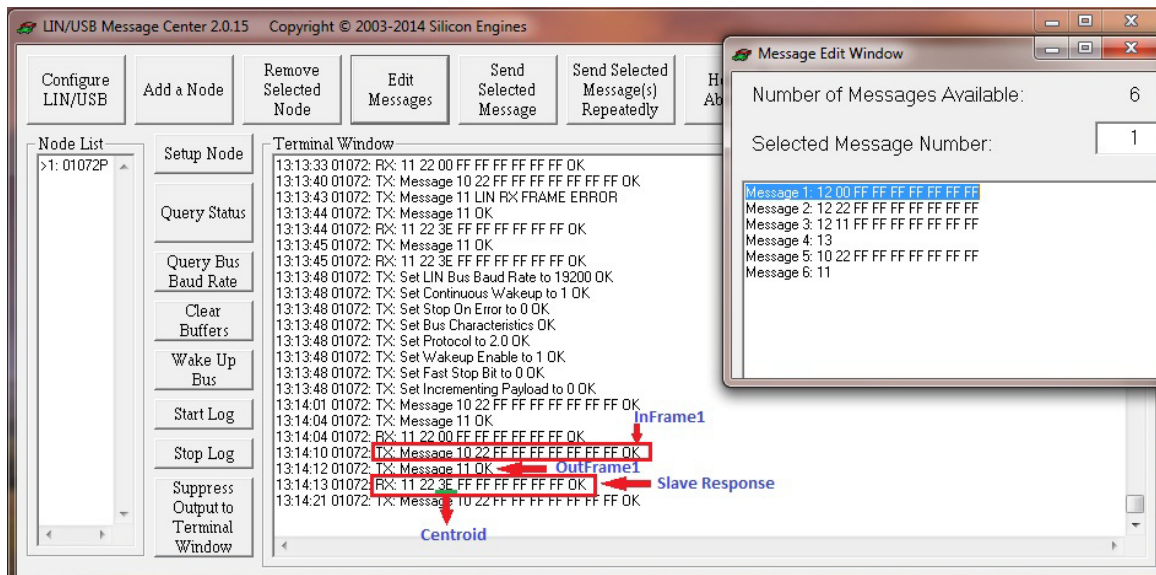

In the above figure, 'InFrame1' refers to "10 22 FF FF FF FF FF FF" where 10 is the frame ID and 22, FF, FF, FF, FF, FF, FF, FF are the eight data bytes. Since the 'InFrame1' in LIN1 slave is configured with only 2 bytes named as InSig1 and InArraySig1, the rest of the data bytes (3 to 8) are ignored by the slave. After receiving this command, the slave will store the current CapSense linear slider centroid position. When the 'OutFrame1' is received from the analyzer as shown in the above figure, the slave responds to the frame with the previously stored CapSense linear slider centroid position value along with frame ID as 11 22 3E where '11' is frame ID, '22' is the previous 'InFrame1' data byte (command) and '3E' is the centroid value.

6. Verifying the LIN slave2 output:

- a. Open the LIN2 analyzer software and go to **Configure LIN/USB**, set the **LIN Bus Baud Rate** to 19200 bps, and then **deselect** the **LIN 2.0-2.1 Protocol** checkbox as shown in [Figure 5-11](#).

Figure 5-11. LIN2 analyzer Configuration

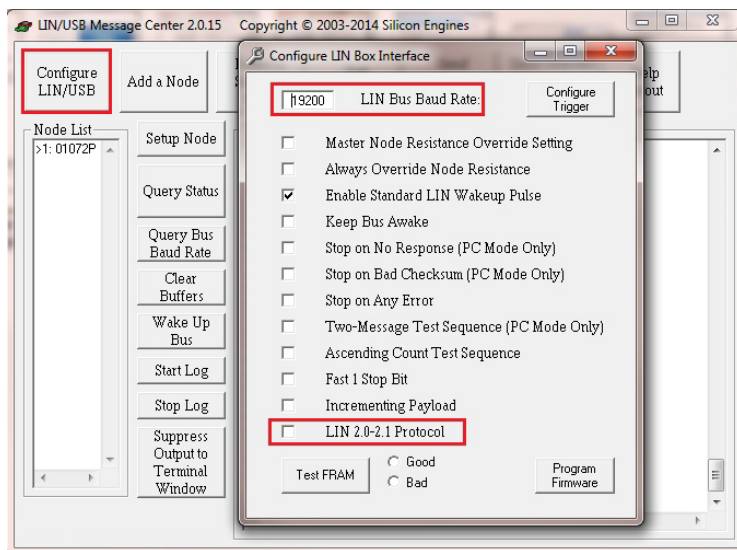

- b. If you are using any other analyzer, make sure that the checksum setting is selected as classic checksum since LIN v1.3 specification supports only enhanced checksum (this option is not required in Silicon Engines LIN-USB converter software).
- c. Add the message/frame in the analyzer software which needs to be transmitted to the slave and send it through the analyzer shown in [Figure 5-8](#).
- d. If a frame with ID = 0x12 is received from the LIN2 analyzer, then the slave controls the RGB LED based on the received data command from master, as provided in [Table 5-11](#). Note that the frame must contain eight data bytes even though the first data byte is the only one used by the slave. The other seven data bytes may be set to any value.

Table 5-11. Slave Response as per the Commands from Master

Command	Slave Response
0x11	Turns ON Red LED
0x22	Turns ON Green LED
0x33	Turns ON Blue LED
0x00	Turns OFF RGB LED

- d. If a frame with ID = 0x13 is received from the LIN2 analyzer, then the slave will send the RGB LED status back to the master, as provided in [Table 5-12](#).

Table 5-12. RGB LED Status

RGB LED Status	Data Byte
Red LED ON	0xAA
Green LED ON	0xBB
Blue LED ON	0xCC
RGB LED OFF	0xDD

- e. The result of transmitted and received data at the LIN2 analyzer is shown in [Figure 5-12](#).

Figure 5-12. Results at LIN2 analyzer

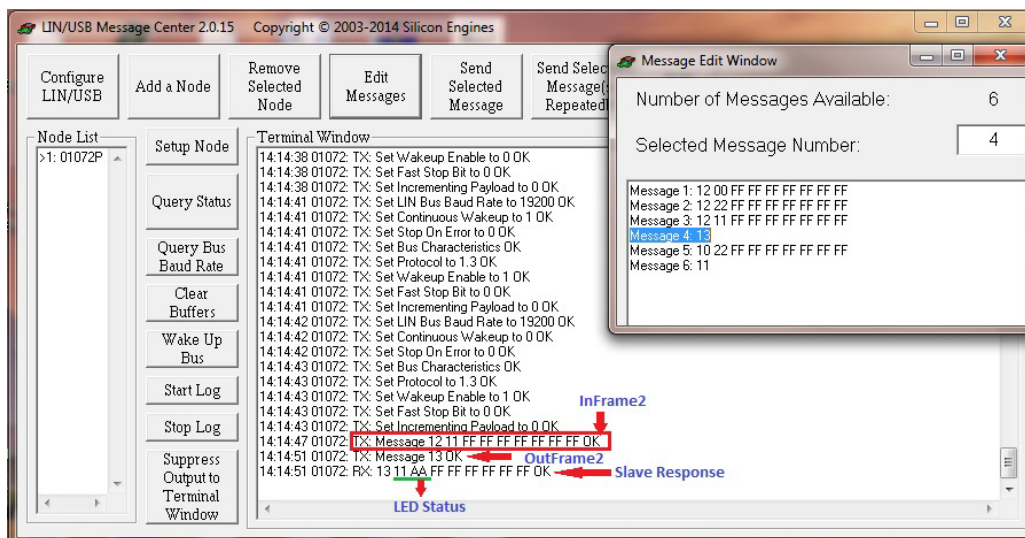

In [Figure 5-12](#), 'InFrame2' refers to "12 11 FF FF FF FF FF FF" where 12 is the frame ID and 11, FF, FF, FF, FF, FF, FF, FF are the eight data bytes. Since, the 'InFrame2' in LIN slave2 is configured with only 2 bytes named as InSig2 and InArraySig2, the rest of the data bytes (3 to 8) are ignored by the slave. When the 'OutFrame2' is received from the analyzer as marked in this figure, the slave responds to the frame with the RGB LED status along with frame ID as 13 11 AA where '13' is frame ID, '11' is the previous 'InFrame2' data byte (command) and 'AA' is the RGB LED status (i.e., Red LED is ON).

**Note:** For more details on how to configure the LIN component, pin configurations, and so on refer to Code Example [CE96999](#).

**Note:** If there is an error message such as "BUS STUCK HIGH" or "TX FRAME ERROR", reset the baseboard (CY8CKIT-042) and LIN analyzer.

# A. Appendix



## A.1 Schematics

Figure A-1. Power Supply Circuit Schematic

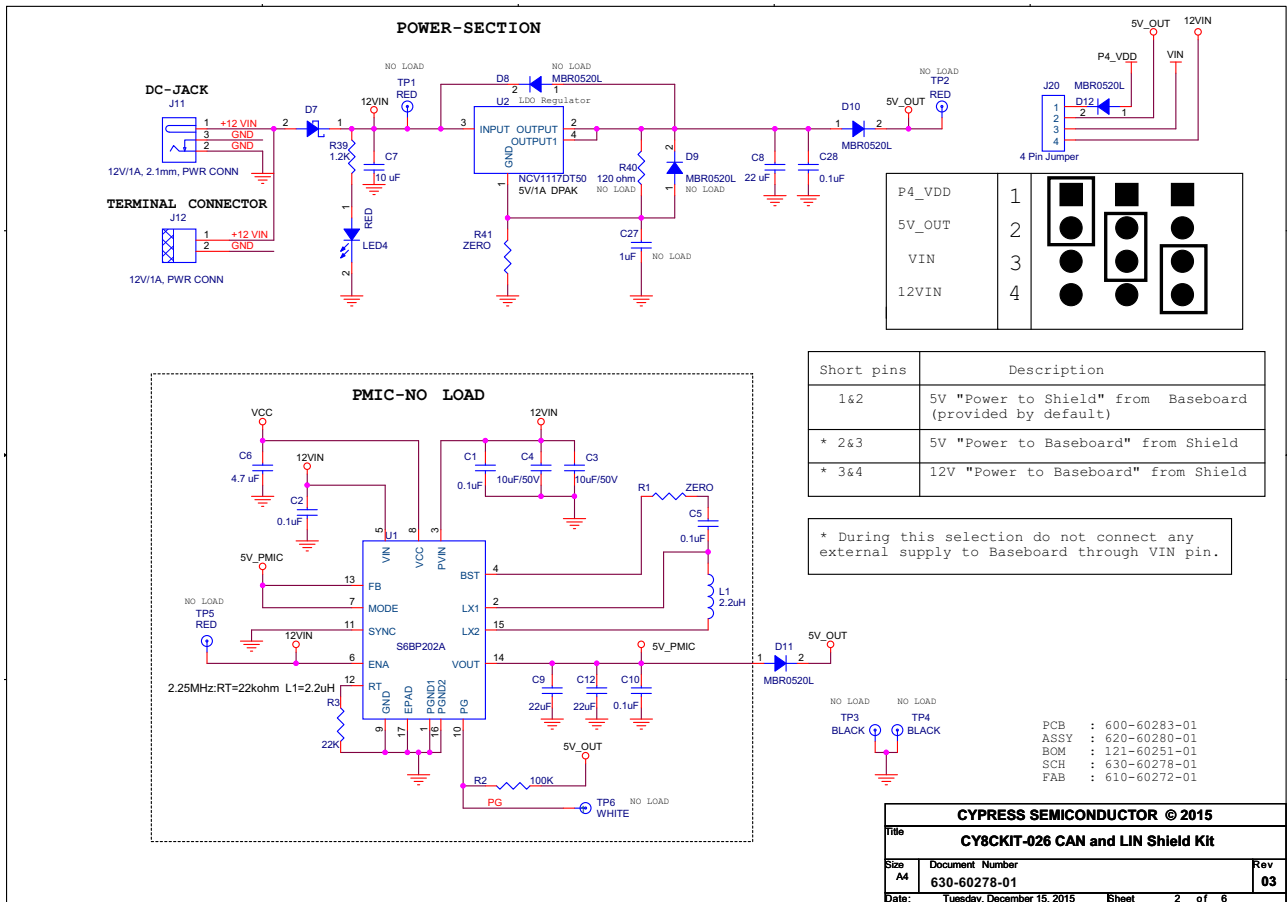

Figure A-2. CAN1 and CAN2 Transceiver Circuit Schematic

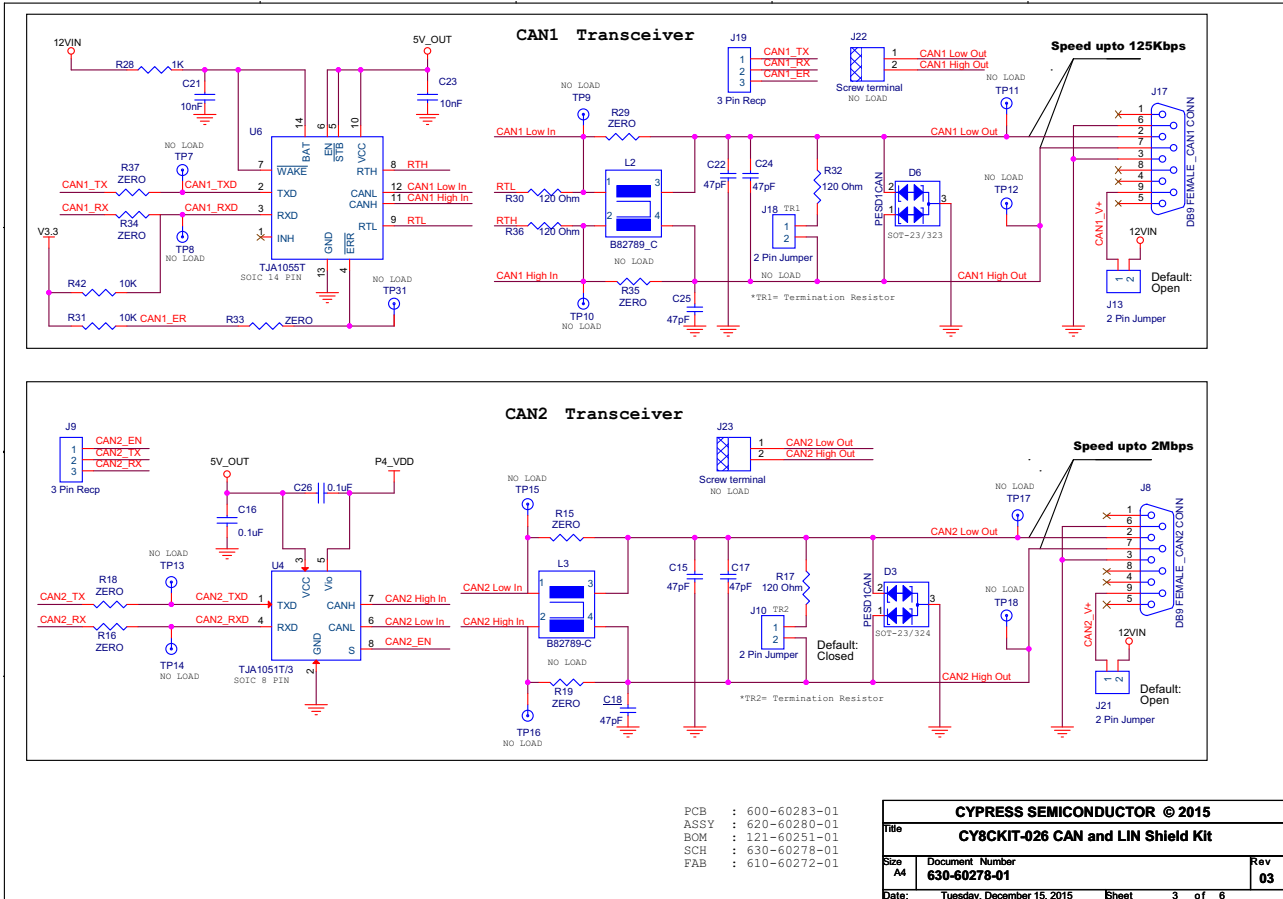

Figure A-3. LIN1 and LIN2 Transceiver Circuit Schematic

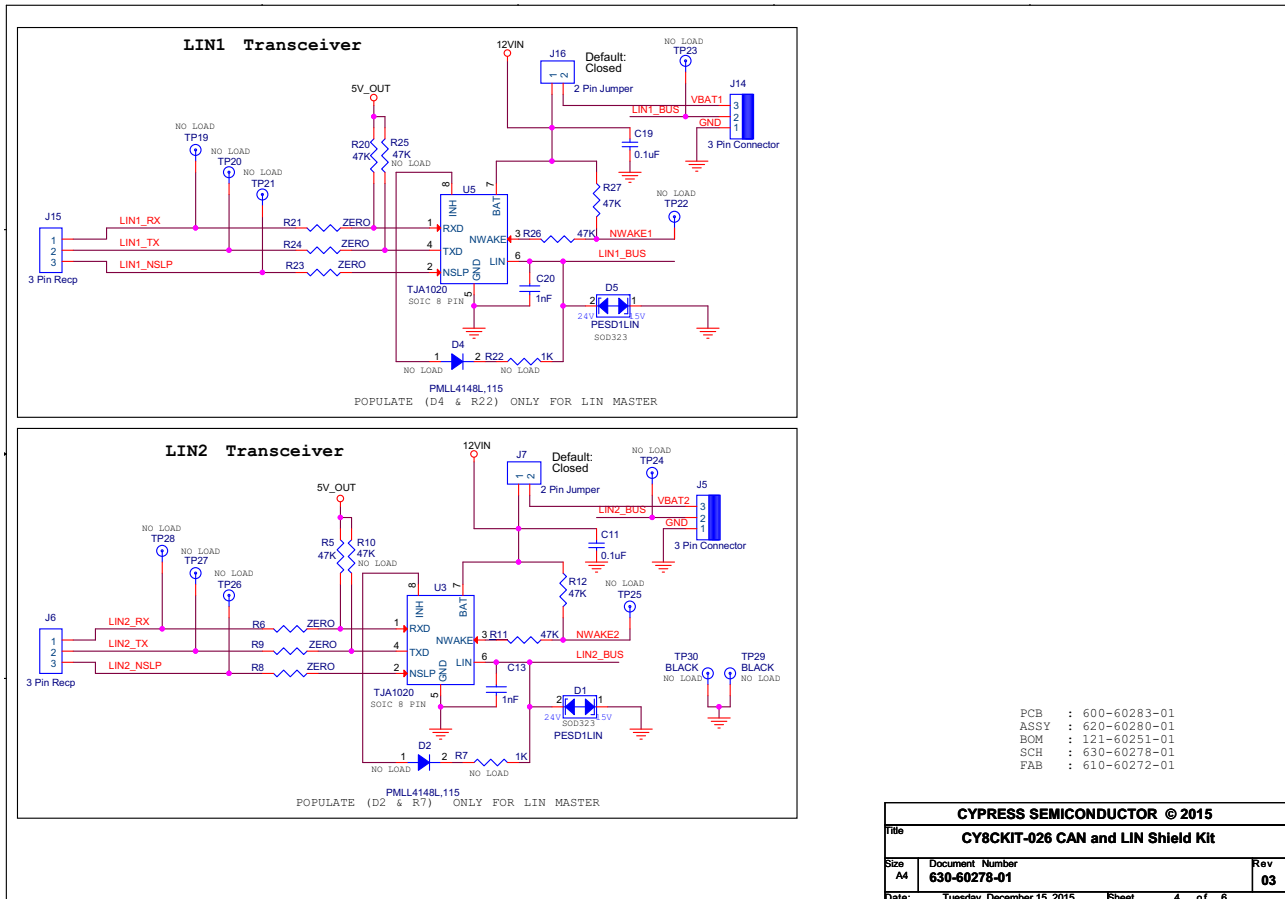
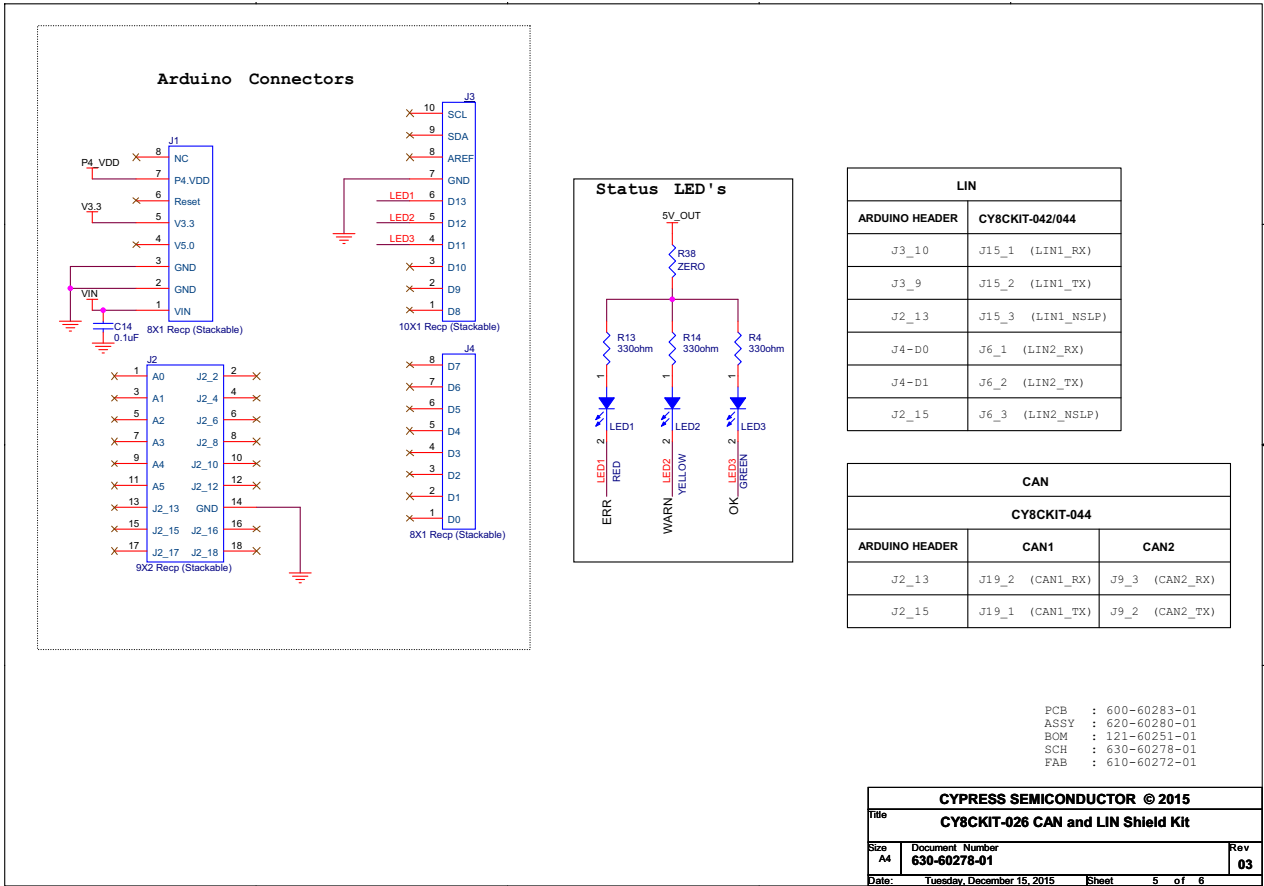



Figure A-4. Arduino Header and Status LEDs Schematic



## A.2 Gerber Files

Figure A-5. CY8CKIT-026 Primary Side

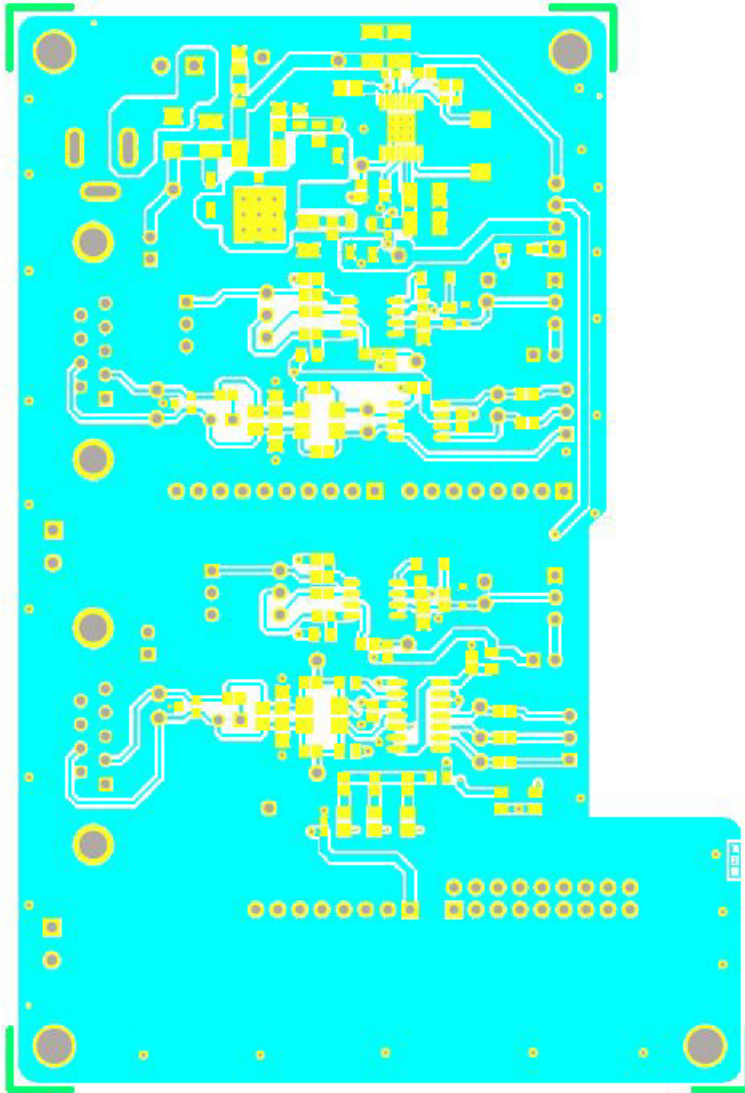

Figure A-6. CY8CKIT-026 Secondary Side

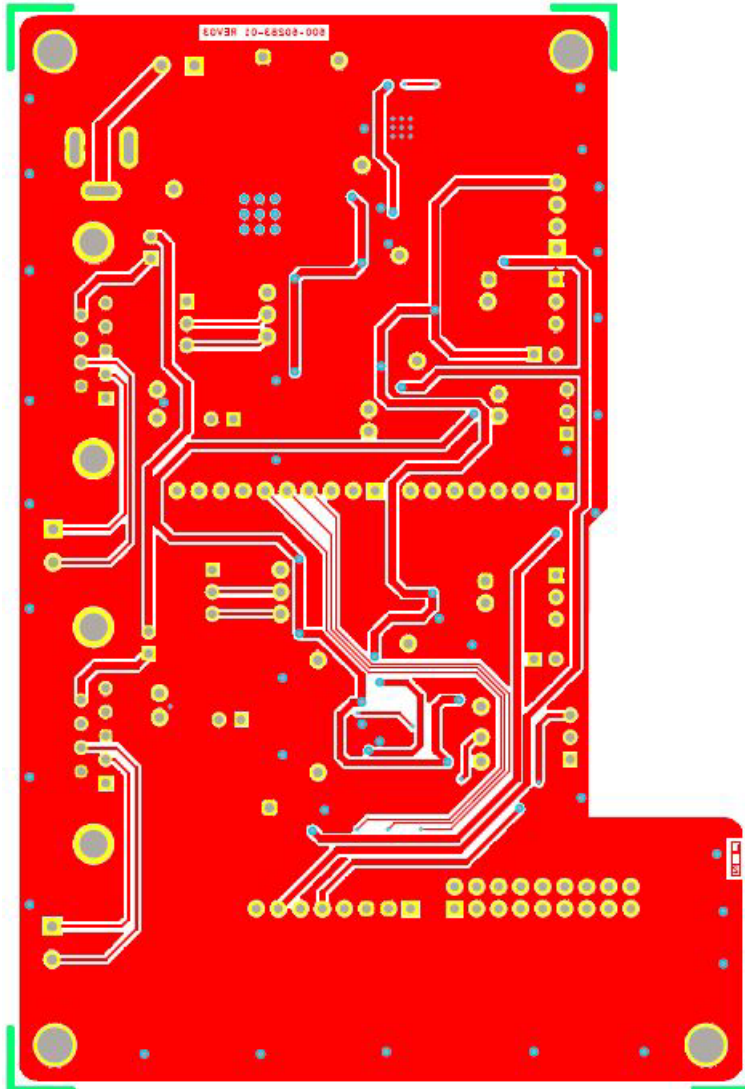

Figure A-7. CY8CKIT-026 Primary Silk Screen

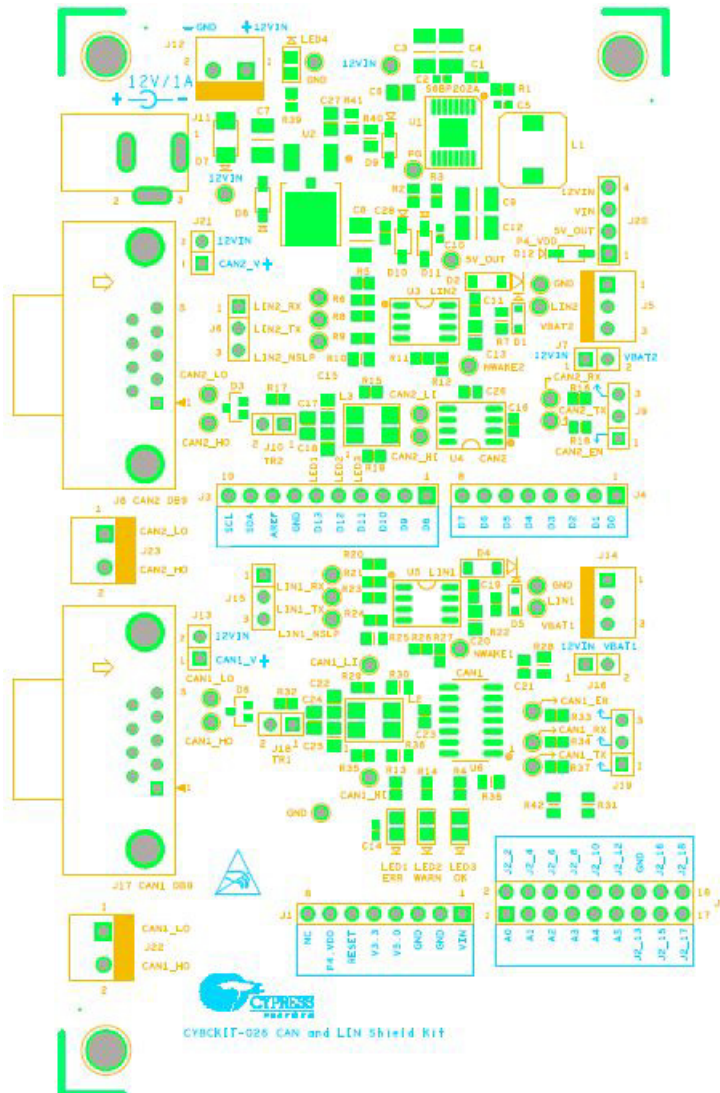
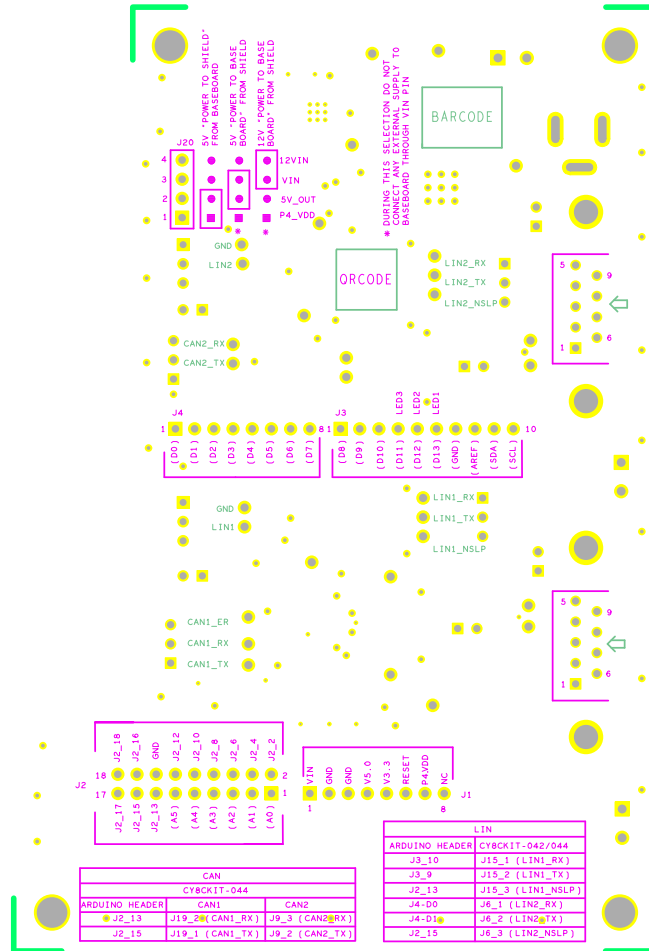

Figure A-8. CY8CKIT-026 Secondary Silk Screen



600-60283-01 REV03 SECONDARY SILKSCREEN

## A.3 Bill of Materials

Table 5-1. Bill of Materials (BOM)

Item	Qty	Reference	Value	Description	Manufacturer	Mfr Part Number	Sub Allowed	ROHS	UL Certified
1	1	600-60283-01	REV03	PCB, 125.00 mm x 85.00 mm, High Tg, ENIG finish, 2 layer, Color = RED, Silk = WHITE	Cypress Semiconductor	600-60283-01	N/A	Yes	Yes
2	5	C11,C16,C19,C26,C28	0.1 uF	CAP CER 0.1 UF 50 V 10% X7R 0603	TDK Corporation	CGA3E2X7R1H104K080AA	ASK	Yes	Yes
3	1	C14	0.1 uF	CAP CER 0.1 UF 50 V 10% X7R 0402	TDK Corporation	CGA2B3X7R1H104K050BB	ASK	Yes	Yes
4	1	C7	10uF/50V	CAP CER 10UF 50 V 20% X7S 1210	TDK Corporation	CGA6P3X7S1H106M250AB	ASK	Yes	Yes
5	1	C8	22uF	CAP CER 22UF 16 V 20% X7R 1210	TDK Corporation	CGA6P1X7R1C226M250AC	ASK	Yes	Yes
6	2	C13,C20	1nF	CAP CER 1000PF 50 V 10% X7R 0805	Murata Electronics	GCM216R71H102KA37D	ASK	Yes	Yes
7	6	C15,C17,C18,C22,C24,C25	47pF	CAP CER 47PF 50 V 5% NP0 0805	Kemet	C0805C470J5GACAUTO	ASK	Yes	Yes
8	2	C21,C23	10nF	CAP CER 10000PF 50 V 10% X7R 0603	Murata Electronics	GCM188R71H103KA37D	ASK	Yes	Yes
9	2	D1,D5	PESD1LIN	TVS DIODE 15VWM/24VWM SOD323	NXP Semiconductors	PESD1LIN,115	ASK	Yes	Yes
10	2	D3,D6	PESD1CAN	TVS DIODE 24VWM 50VC SC-70, SOT-323	NXP Semiconductors	PESD1CAN-UX	ASK	Yes	Yes
11	1	D7	SS12-E3/61T	DIODE SCHOTTKY 20 V 1 A DO214AC	Vishay Semiconductor	SS12-E3/61T	ASK	Yes	Yes
12	3	D10,D11,D12	MBR0520L	DIODE SCHOTTKY 20 V 500MA SOD123	Fairchild Semiconductor	MBR0520L	ASK	Yes	Yes
13	2	J1,J4	8X1 RECP (Stackable)	Connector Receptacle 8 Position 0.100" (2.54 mm) Gold Through Hole	Samtec Inc.	SSQ-108-03-G-S	ASK	Yes	Yes
14	1	J2	9X2 RECP (Stackable)	Connector Receptacle 18 Position 0.100" (2.54 mm) Gold Through Hole [9x2]	Samtec Inc.	SSQ-109-03-G-D	ASK	Yes	Yes
15	1	J3	10X1 RECP (Stackable)	Connector Receptacle 10 Position 0.100" (2.54 mm) Gold Through Hole	Samtec Inc.	SSQ-110-03-G-S	ASK	Yes	Yes
16	2	J5,J14	22-23-2031	CONN HEADER 3POS .100 VERT TIN [KEYED]	Molex Inc.	22232031	ASK	Yes	Yes
17	4	J6,J9,J15,J19	3x1 Recp	Connector Header 3 Position 0.100" (2.54 mm) Gold Through Hole [Female Socket]	Sullins Connector Solutions	PPPC031LFB N-RC	ASK	Yes	Yes
18	5	J7,J10,J13,J16,J21	2x1 Jumper	CONN HEADR BRKWAY .100 2POS STR	TE Connectivity AMP Connectors	5-146280-2	ASK	Yes	Yes

Table 5-1. Bill of Materials (BOM) (continued)

Item	Qty	Reference	Value	Description	Manufacturer	Mfr Part Number	Sub Allowed	ROHS	UL Certified
19	2	J8,J17	DB9 FEMALE _CAN CONN	D-Sub Connector Receptacle, Female Sockets 9 Position Through Hole, Right Angle Solder	TE Connectivity AMP Connectors	5747844-4	ASK	Yes	Yes
20	1	J11	12 V/1 A, 2.1mm, PWR CONN	CONN JACK POWER 2.1 MM PCB	CUI Inc.	PJ-102A	ASK	Yes	Yes
21	1	J12	12 V POWER CONN	TERM BLOCK 2POS SIDE ENT 3.81 MM	TE Connectivity AMP Connectors	1776113-2	ASK	Yes	Yes
22	1	J20	4x1 Jumper	CONN HEADR BRKWAY .100 4POS STR	TE Connectivity AMP Connectors	5-146280-4	ASK	Yes	Yes
23	2	LED1,LED4	STATUS LED RED, POWER LED RED RESPECTIVELY	LED SUPER RED CLEAR 0805 SMD	Lite-On Inc.	LTST- C170KRKT	ASK	Yes	Yes
24	1	LED2	STATUS LED YELLOW	LED YELLOW CLEAR 0805 SMD	Lite-On Inc.	LTST- C171KSKT	ASK	Yes	Yes
25	1	LED3	STATUS LED GREEN	LED GREEN CLEAR 0805 SMD	Lite-On Inc.	LTST- C170KGKT	ASK	Yes	Yes
26	3	R4,R13,R14	330 Ohm	RES SMD 330 OHM 1% 1/10 W 0603	Panasonic Electronic Components	ERJ- 3EKF3300V	ASK	Yes	Yes
27	6	R5,R11,R12,R 20,R26,R27	47K	RES SMD 47 KOHM 1% 1/10 W 0603	Panasonic Electronic Components	ERJ- 3EKF4702V	ASK	Yes	Yes
28	15	R6,R8,R9,R15 ,R16,R18,R19, R21,R23,R24, R29,R33,R34, R35,R37	ZERO	RES SMD 0.0 OHM JUMPER 1/10 W	Panasonic Electronic Components	ERJ- 3GEY0R00V	ASK	Yes	Yes
29	2	R17,R32	120 Ohm	RES SMD 120 OHM 1% 1/10 W 0603	Panasonic Electronic Components	ERJ- 3EKF1200V	ASK	Yes	Yes
30	1	R28	1K	RES SMD 1 KOHM 1% 1/8 W 0805	Panasonic Electronic Components	ERJ- 6ENF1001V	ASK	Yes	Yes
31	2	R31,R42	10K	RES SMD 10 KOHM 1% 1/8 W 0805	Panasonic Electronic Components	ERJ- 6ENF1002V	ASK	Yes	Yes
32	2	R38,R41	ZERO	RES SMD 0.0 OHM JUMPER 1/8 W 0805	Panasonic Electronic Components	ERJ- 6GEY0R00V	ASK	Yes	Yes
33	1	R39	1.2K	RES SMD 1.2 KOHM 1% 1/10 W 0603	Panasonic Electronic Components	ERJ- 3EKF1201V	ASK	Yes	Yes
34	2	R30,R36,	120 ohm	RES SMD 120 OHM 1% 1/8 W 0805	Panasonic Electronic Components	ERJ- 6ENF1200V	ASK	Yes	Yes
35	1	U2	NCV1117DT50	IC REG LDO 5 V 1 A DPAK	ON Semiconductor	NCV1117DT50 RKG	NO	NO	NO
36	2	U3,U5	TJA1020	IC TRANSCEIVER LIN 8SOIC	NXP Semiconductors	TJA1020T/ CM,118	NO	NO	NO
37	1	U4	TJA1051T/3	IC CAN TRANSEIVER HS 8SOIC	NXP Semiconductors	TJA1051T/ 3,118	NO	NO	NO

Table 5-1. Bill of Materials (BOM) (continued)

Item	Qty	Reference	Value	Description	Manufacturer	Mfr Part Number	Sub Allowed	ROHS	UL Certified
38	1	U6	TJA1055T	IC TXRX CAN FAULT-TOL 14SOIC	NXP Semiconductors	TJA1055T3/C,518	NO	NO	NO
Jumper Installation Instructions									
39	4	J7,J10,J16,J20	Install jumper across pins 1 and 2	Rectangular Connectors MINI JUMPER GF 6.0 MM CLOSE TYPE BLACK	Kobiconn	151-8010-E	ASK	Yes	Yes
Label									
40	1	N/A	N/A	LBL, PCA Label, Vendor Code, Datecode, Serial Number 121-60251-01 (YYWWVVXXXXX)	Cypress Semiconductor		ASK	Yes	Yes
41	1	N/A	N/A	LBL, QR code, 10 mm X 10 mm	Cypress Semiconductor		ASK	Yes	Yes
No Load Components									
42	1	C1	0.1 uF	CAP CER 0.1 UF 50 V 10% X7R 0603	TDK Corporation	CGA3E2X7R1H104K080AA	ASK	Yes	Yes
43	3	C2,C5,C10	0.1 uF	CAP CER 0.1 UF 50 V 10% X7R 0402	TDK Corporation	CGA2B3X7R1H104K050BB	ASK	Yes	Yes
44	2	C3,C4	10u/50V	CAP CER 10 UF 50 V 20% X7S 1210	TDK Corporation	CGA6P3X7S1H106M250AB	ASK	Yes	Yes
45	1	C6	4.7 uF	CAP CER 4.7 UF 16 V 10% X7R 0805	TDK Corporation	CGA4J3X7R1C475K125AB	ASK	Yes	Yes
46	2	C9,C12	22uF	CAP CER 22 UF 16 V 20% X7R 1210	TDK Corporation	CGA6P1X7R1C226M250AC	ASK	Yes	Yes
47	1	C27	1uF	CAP CER 1UF 16 V 10% X7R 0805	TDK Corporation	CGA4J2X7R1C105K125AA	ASK	Yes	Yes
48	2	D2,D4	PMLL4148L, 115	DIODE GEN PURP 75 V 200 MA LLDS	NXP Semiconductors	PMLL4148L,115	ASK	Yes	Yes
49	2	D8,D9,	MBR0520L	DIODE SCHOTTKY 20 V 500MA SOD123	Fairchild Semiconductor	MBR0520L	ASK	Yes	Yes
50	1	J18	2x1 Jumper	CONN HEADR BRKWAY .100 2POS STR	TE Connectivity AMP Connectors	5-146280-2	ASK	Yes	Yes
51	2	J22,J23	Screwterminal CONN	TERM BLOCK 2POS SIDE ENT 3.81 MM	TE Connectivity AMP Connectors	1776113-2	ASK	Yes	Yes
52	1	L1	2.2uH	FIXED IND 2.2 UH 4.3 A 14.6 MOHM	TDK Corporation	CLF7045T-2R2N-D	ASK	Yes	Yes
53	2	L2,L3	B82789-C	CHOKE DBL 100 UH 150 MA GOLD SMD [Common Mode Filters / Chokes]	EPCOS / TDK	B82789C104N1	ASK	Yes	Yes
54	1	R1	ZERO	RES SMD 0.0 OHM JUMPER 1/10 W	Panasonic Electronic Components	ERJ-3GEY0R00V	ASK	Yes	Yes
55	1	R2	100K	RES SMD 100 KOHM 1% 1/10 W 0603	Panasonic Electronic Components	ERJ-3EKF1003V	ASK	Yes	Yes



Table 5-1. Bill of Materials (BOM) (continued)

Item	Qty	Reference	Value	Description	Manufacturer	Mfr Part Number	Sub Allowed	ROHS	UL Certified
56	1	R3	22K	RES SMD 22 KOHM 1% 1/10 W 0603	Panasonic Electronic Components	ERJ-3EKF2202V	ASK	Yes	Yes
57	1	R7	1K	RES SMD 1 KOHM 1% 1/8 W 0805	Panasonic Electronic Components	ERJ-6ENF1001V	ASK	Yes	Yes
58	2	R10,R25,	47K	RES SMD 47 KOHM 1% 1/8 W 0805	Panasonic Electronic Components	ERJ-6ENF4702V	ASK	Yes	Yes
59	1	R22	1K	RES SMD 1 KOHM 1% 1/10 W 0603	Panasonic Electronic Components	ERJ-3EKF1001V	ASK	Yes	Yes
60	1	R40	120 ohm	RES SMD 120 OHM 1% 1/8 W 0805	Panasonic Electronic Components	ERJ-6ENF1200V	ASK	Yes	Yes
61	3	TP1,TP2,TP5,	RED	TEST POINT 43 HOLE 65 PLATED RED	Keystone Electronics	5000	ASK	Yes	Yes
62	4	TP3,TP4,TP29,TP30	BLACK	TEST POINT 43 HOLE 65 PLATED BLACK	Keystone Electronics	5001	ASK	Yes	Yes
63	24	TP6,TP7, TP8, TP9, TP10, TP11, TP12, TP13, ,TP14,TP15, TP16,TP17,TP18 ,TP19,TP20,TP21,TP22,TP23,TP24,TP25, TP26, TP27,TP28,TP31	WHITE	TEST POINT 43 HOLE 65 PLATED WHITE	Keystone Electronics	5002	ASK	Yes	Yes
64	1	U1	S6BP202A	S6BP202A is a single output Buck-Boost DC/DC, TSSOP-16 PIN	Cypress	S6BP202A	No	No	No

# Revision History



## Document Revision History

Document Title: CY8CKIT-026 CAN and LIN Shield Kit Guide				
Document Number: 002-03798				
Revision	ECN#	Issue Date	Origin of Change	Description of Change
**	5068393	12/29/2015	MVRE	Initial version.
*A	5129706	03/02/2016	MVRE	Minor text edits across the document. Updated <a href="#">Introduction chapter on page 6</a> : Updated "Kit Contents" on page 6: Updated description. Updated <a href="#">Figure 1-1</a> . Updated "Getting Started" on page 7: Updated "Beginner Resources" on page 8: Updated description. Updated "Hardware Requirements" on page 8: Updated description. Updated "Additional Learning Resources" on page 9: Updated description. Updated <a href="#">Kit Operation chapter on page 30</a> : Updated "CAN Communication Hardware Setup" on page 30: Updated <a href="#">Table 4-2</a> : Replaced "J19_3" with "J19_1".
*B	5169205	03/10/2016	MVRE	Updated <a href="#">Introduction chapter on page 6</a> : Updated description. Updated "Kit Contents" on page 6: Updated "Kit Compatibility" on page 7: Updated description. Updated <a href="#">Hardware chapter on page 15</a> : Updated "System Block Diagram" on page 15: Updated description.



Компания «ЭлектроПласт» предлагает заключение долгосрочных отношений при поставках импортных электронных компонентов на взаимовыгодных условиях!

Наши преимущества:

- Оперативные поставки широкого спектра электронных компонентов отечественного и импортного производства напрямую от производителей и с крупнейших мировых складов;
- Поставка более 17-ти миллионов наименований электронных компонентов;
- Поставка сложных, дефицитных, либо снятых с производства позиций;
- Оперативные сроки поставки под заказ (от 5 рабочих дней);
- Экспресс доставка в любую точку России;
- Техническая поддержка проекта, помощь в подборе аналогов, поставка прототипов;
- Система менеджмента качества сертифицирована по Международному стандарту ISO 9001;
- Лицензия ФСБ на осуществление работ с использованием сведений, составляющих государственную тайну;
- Поставка специализированных компонентов (Xilinx, Altera, Analog Devices, Intersil, Interpoint, Microsemi, Aeroflex, Peregrine, Syfer, Eurofarad, Texas Instrument, Miteq, Cobham, E2V, MA-COM, Hittite, Mini-Circuits, General Dynamics и др.);

Помимо этого, одним из направлений компании «ЭлектроПласт» является направление «Источники питания». Мы предлагаем Вам помощь Конструкторского отдела:

- Подбор оптимального решения, техническое обоснование при выборе компонента;
- Подбор аналогов;
- Консультации по применению компонента;
- Поставка образцов и прототипов;
- Техническая поддержка проекта;
- Защита от снятия компонента с производства.



#### Как с нами связаться

**Телефон:** 8 (812) 309 58 32 (многоканальный)

**Факс:** 8 (812) 320-02-42

**Электронная почта:** [org@eplast1.ru](mailto:org@eplast1.ru)

**Адрес:** 198099, г. Санкт-Петербург, ул. Калинина, дом 2, корпус 4, литера А.