

NHD-3.5-320240MF-20 Controller Board

TFT Controller Evaluation Board

NHD-	Newhaven Display
3.5-	3.5" Diagonal
320240-	320xRGBx240 pixels
MF-	Model
20-	20-POS FFC interface (8-bit data) SSD1963 Controller

Newhaven Display International, Inc.

2511 Technology Drive, Suite 101

Elgin IL, 60124

Ph: 847-844-8795

Fax: 847-844-8796

www.newhavendisplay.com

nhtech@newhavendisplay.com

nhsales@newhavendisplay.com

Document Revision History

Revision	Date	Description	Changed by
0	5/14/2007	Initial Release	CL
1	4/17/2012	Mechanical drawing updated	AK
2	4/27/2012	J2 Pin description updated	AK
3	1/25/2013	J2 Pin description updated	AK

Functions and Features

- To use for testing, evaluating, or in final production with NHD-3.5-320240MF-A displays.

Mechanical Drawing

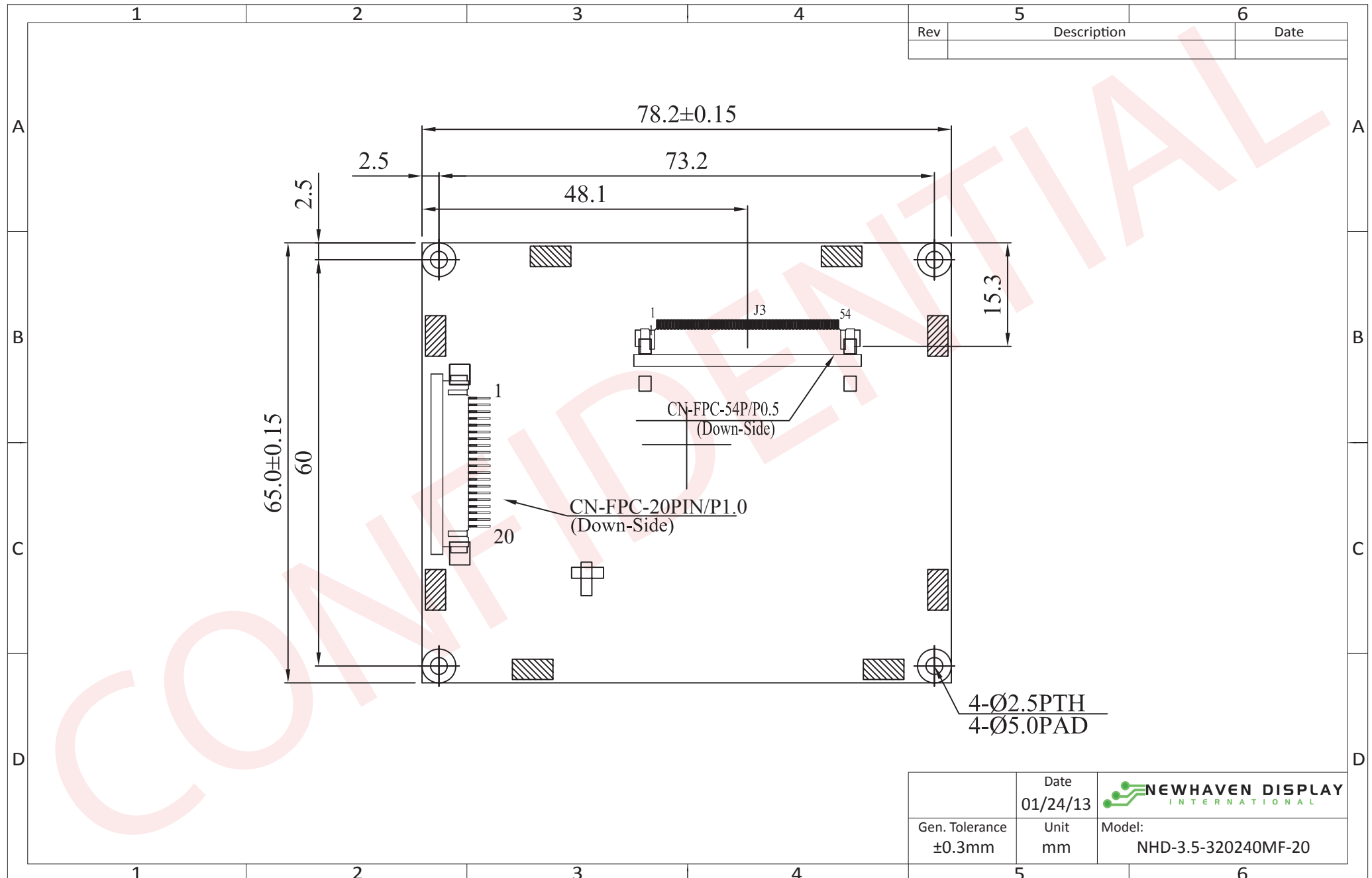

The drawing contained herein is the exclusive property of Newhaven Display International, Inc. and shall not be copied, reproduced, and/or disclosed in any format without permission.

Pin Description

J2 (SSD1963 input from user's MPU):

Pin No.	Symbol	External Connection	Function Description
1	VSS	Power Supply	Ground
2	VDD	Power Supply	Power supply for LCD and logic (3.3V)
3	B/L Enable	Power Supply	Backlight Enable
4	RS	MPU	Register Select. RS=0: Command, RS=1: Data
5	/WR	MPU	8080 mode: Active LOW Write
6	/RD	MPU	8080 mode: Active LOW Read
7-14	DB0-DB7	MPU	8-bit bidirectional data bus
15	/CS	MPU	Active LOW Chip Select
16	/RST	MPU	Active LOW Reset
17	NC	-	No Connect
18	NC	-	No Connect
19	NC	-	No Connect
20	NC	-	No Connect

J3, J4 (SSD1963 output to display panel):

Pin No.	Symbol	External Connection	Function Description
1	LED-	LED Power Supply	Ground for backlight
2	LED-	LED Power Supply	Ground for backlight
3	LED+	LED Power Supply	Power for backlight
4	LED+	LED Power Supply	Power for backlight
5-7	NC	-	No Connect
8	/RST	MPU	Active LOW Reset
9	/CS	-	Active LOW Serial Chip Select (No Connect)
10	SCL	-	Serial Clock (No Connect)
11	SDA	-	Serial Data (No Connect)
12-19	[B0-B7]	MPU	Blue Data
20-27	[G0-G7]	MPU	Green Data
28-35	[R0-R7]	MPU	Red Data
36	HSYNC	MPU	Horizontal (Line) Sync
37	VSYNC	MPU	Vertical (Frame) Sync
38	DCLK	MPU	Dot Clock
39-40	NC	-	No Connect
41	VDD	Power Supply	Power supply for LCD and logic (3.3V)
42	VDD	Power Supply	Power supply for LCD and logic (3.3V)
43-51	NC	-	No Connect
52	DE	-	Data Enable (No Connect)
53	VSS	Power Supply	Ground
54	VSS	Power Supply	Ground

Electrical Characteristics

Item	Symbol	Condition	Min.	Typ.	Max.	Unit
Operating Temperature Range	Top	Absolute Max	-20	-	+70	°C
Storage Temperature Range	Tst	Absolute Max	-30	-	+80	°C
Supply Voltage	VDD		3.0	3.3	3.6	V
Supply Current	IDD		-	25	-	mA
Input High Voltage	VIH		0.8*VDD	-	VDD	V
Input Low Voltage	VIL		VSS	-	0.2*VDD	V
Backlight Voltage	VLED	ILED=20mA	18	19.2	20.4	V
Backlight Current	ILED		-	18	20	mA

Controller Information

Built-in SSD1963 controller

Please download specification at http://www.newhavendisplay.com/app_notes/SSD1963.pdf

MCU Interface

The controller board operates in 8080 mode. This interface uses /WR to define a write cycle and /RD for read cycle. If /WR goes low when the /CS signal is low, the data or command will be latched into the system at the rising edge of /WR. Similarly, the read cycle will start when /RD goes low and end at the rising edge of /RD.

Pixel Data Format

Interface	Cycle	D[23]	D[22]	D[21]	D[20]	D[19]	D[18]	D[17]	D[16]	D[15]	D[14]	D[13]	D[12]	D[11]	D[10]	D[9]	D[8]	D[7]	D[6]	D[5]	D[4]	D[3]	D[2]	D[1]	D[0]
24 bits	1 st	R7	R6	R5	R4	R3	R2	R1	R0	G7	G6	G5	G4	G3	G2	G1	G0	B7	B6	B5	B4	B3	B2	B1	B0
18 bits	1 st							R5	R4	R3	R2	R1	R0	G5	G4	G3	G2	G1	G0	B5	B4	B3	B2	B1	B0
16 bits (565 format)	1 st									R5	R4	R3	R2	R1	G5	G4	G3	G2	G1	G0	B5	B4	B3	B2	B1
16 bits	1 st									R7	R6	R5	R4	R3	R2	R1	R0	G7	G6	G5	G4	G3	G2	G1	G0
	2 nd									B7	B6	B5	B4	B3	B2	B1	B0	R7	R6	R5	R4	R3	R2	R1	R0
	3 rd									G7	G6	G5	G4	G3	G2	G1	G0	B7	B6	B5	B4	B3	B2	B1	B0
12 bits	1 st													R7	R6	R5	R4	R3	R2	R1	R0	G7	G6	G5	G4
	2 nd													G3	G2	G1	G0	B7	B6	B5	B4	B3	B2	B1	B0
9 bits	1 st																R5	R4	R3	R2	R1	R0	G5	G4	G3
	2 nd																G2	G1	G0	B5	B4	B3	B2	B1	B0
8 bits	1 st																	R7	R6	R5	R4	R3	R2	R1	R0
	2 nd																	G7	G6	G5	G4	G3	G2	G1	G0
	3 rd																	B7	B6	B5	B4	B3	B2	B1	B0

Timing Characteristics

Parallel 8080-series Interface Timing

Symbol	Parameter	Min	Typ	Max	Unit
f_{MCLK}	System Clock Frequency*	1	-	110	MHz
t_{MCLK}	System Clock Period*	$1/f_{MCLK}$	-	-	ns
t_{PWCSL}	Control Pulse High Width Write Read	13 30	$1.5 * t_{MCLK}$ $3.5 * t_{MCLK}$	-	ns
t_{PWCSH}	Control Pulse Low Width Write (next write cycle) Write (next read cycle) Read	13 80 80	$1.5 * t_{MCLK}$ $9 * t_{MCLK}$ $9 * t_{MCLK}$	-	ns
t_{AS}	Address Setup Time	1	-	-	ns
t_{AH}	Address Hold Time	2	-	-	ns
t_{DSW}	Write Data Setup Time	4	-	-	ns
t_{DHW}	Write Data Hold Time	1	-	-	ns
t_{PWLW}	Write Low Time	12	-	-	ns
t_{DHR}	Read Data Hold Time	1	-	-	ns
t_{ACC}	Access Time	32	-	-	ns
t_{PWLR}	Read Low Time	36	-	-	ns
t_R	Rise Time	-	-	0.5	ns
t_F	Fall Time	-	-	0.5	ns
t_{CS}	Chip select setup time	2	-	-	ns
t_{CSH}	Chip select hold time to read signal	3	-	-	ns

* System Clock denotes external input clock (PLL-bypass) or internal generated clock (PLL-enabled)

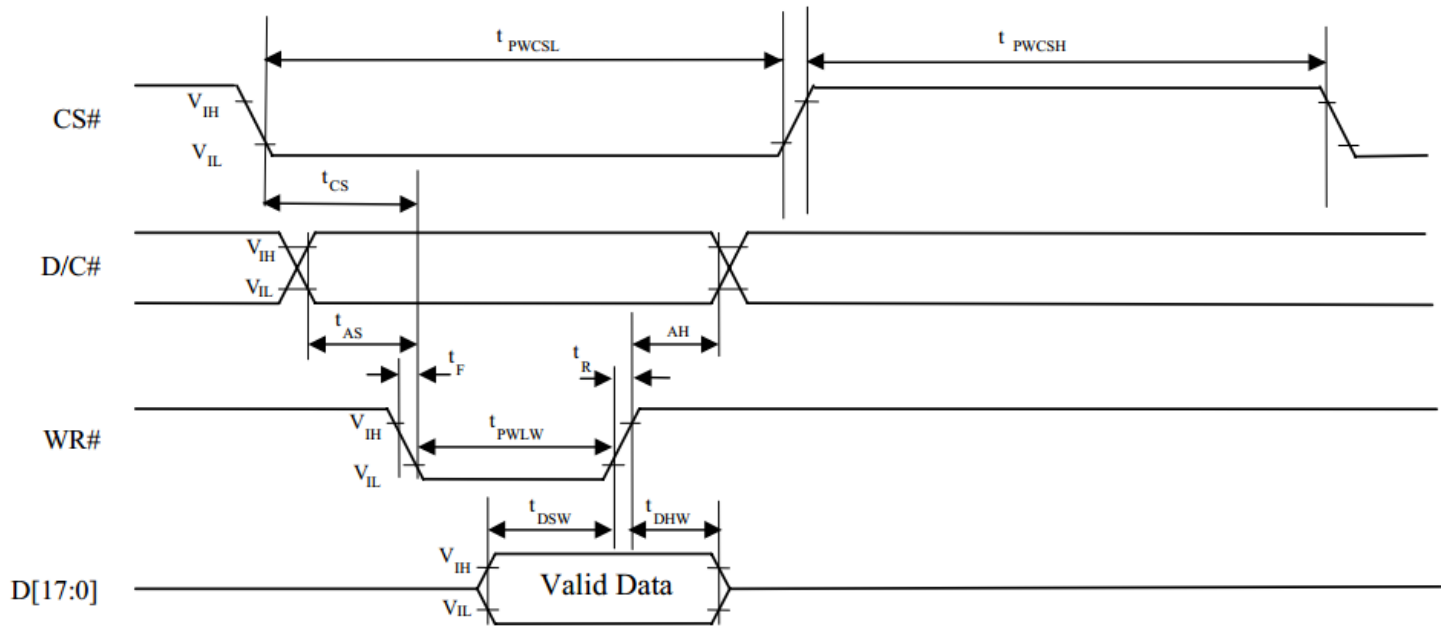

Quality Information

Test Item	Content of Test	Test Condition	Note
High Temperature storage	Endurance test applying the high storage temperature for a long time.	+80°C , 200hrs	2
Low Temperature storage	Endurance test applying the low storage temperature for a long time.	-30°C , 200hrs	1,2
High Temperature Operation	Endurance test applying the electric stress (voltage & current) and the high thermal stress for a long time.	+70°C 200hrs	2
Low Temperature Operation	Endurance test applying the electric stress (voltage & current) and the low thermal stress for a long time.	-20°C , 200hrs	1,2
High Temperature / Humidity Operation	Endurance test applying the electric stress (voltage & current) and the high thermal with high humidity stress for a long time.	+60°C , 90% RH , 96hrs	1,2
Thermal Shock resistance	Endurance test applying the electric stress (voltage & current) during a cycle of low and high thermal stress.	-20°C,30min -> 25°C,5min -> 70°C,30min = 1 cycle 10 cycles	
Vibration test	Endurance test applying vibration to simulate transportation and use.	10-55Hz , 15mm amplitude. 60 sec in each of 3 directions X,Y,Z For 15 minutes	3
Static electricity test	Endurance test applying electric static discharge.	VS=800V, RS=1.5kΩ, CS=100pF One time	

Note 1: No condensation to be observed.

Note 2: Conducted after 4 hours of storage at 25°C, 0%RH.

Note 3: Test performed on product itself, not inside a container.

Precautions for using LCDs/LCMs

See Precautions at www.newhavendisplay.com/specs/precautions.pdf

Warranty Information and Terms & Conditions

http://www.newhavendisplay.com/index.php?main_page=terms



Компания «ЭлектроПласт» предлагает заключение долгосрочных отношений при поставках импортных электронных компонентов на взаимовыгодных условиях!

Наши преимущества:

- Оперативные поставки широкого спектра электронных компонентов отечественного и импортного производства напрямую от производителей и с крупнейших мировых складов;
- Поставка более 17-ти миллионов наименований электронных компонентов;
- Поставка сложных, дефицитных, либо снятых с производства позиций;
- Оперативные сроки поставки под заказ (от 5 рабочих дней);
- Экспресс доставка в любую точку России;
- Техническая поддержка проекта, помощь в подборе аналогов, поставка прототипов;
- Система менеджмента качества сертифицирована по Международному стандарту ISO 9001;
- Лицензия ФСБ на осуществление работ с использованием сведений, составляющих государственную тайну;
- Поставка специализированных компонентов (Xilinx, Altera, Analog Devices, Intersil, Interpoint, Microsemi, Aeroflex, Peregrine, Syfer, Eurofarad, Texas Instrument, Miteq, Cobham, E2V, MA-COM, Hittite, Mini-Circuits, General Dynamics и др.);

Помимо этого, одним из направлений компании «ЭлектроПласт» является направление «Источники питания». Мы предлагаем Вам помощь Конструкторского отдела:

- Подбор оптимального решения, техническое обоснование при выборе компонента;
- Подбор аналогов;
- Консультации по применению компонента;
- Поставка образцов и прототипов;
- Техническая поддержка проекта;
- Защита от снятия компонента с производства.



Как с нами связаться

Телефон: 8 (812) 309 58 32 (многоканальный)

Факс: 8 (812) 320-02-42

Электронная почта: org@eplast1.ru

Адрес: 198099, г. Санкт-Петербург, ул. Калинина, дом 2, корпус 4, литера А.