

Main

Range of product	Harmony 9001SK
Product or component type	Illuminated mushroom head push-button
Device short name	9001SK
Type of operator	Push-pull
Operator profile	Red mushroom Ø 41 mm unmarked
Light block supply	Direct

Complementary

Bezel material	Plastic
Mounting diameter	1.18 in (30 mm)
Product weight	0.5 lb(US) (0.226 kg)
Operating position	Any position
Shape of signaling unit head	Round
Operator position information	2 positions
Contacts type and composition	1 NC (late-break) 1 NC (slow-break)
Contacts type and composition	2 NC
Positive opening	With conforming to IEC 60947-5-2
Mechanical durability	5000000 cycles
Connections - terminals	Screw clamp terminals (1 x 0.22...2 x 1.5 mm ²) conforming to IEC 60947-1
Tightening torque	7.08 lbf.in (0.8 N.m) conforming to IEC 60947-1
Shape of screw head	Cross slotted head
Contacts material	Silver alloy contacts
Short-circuit protection	10 A cartridge fuse conforming to IEC 60947-5-1
[I _{th}] conventional free air thermal current	10 A
[U _i] rated insulation voltage	250 V (degree of pollution: 3) conforming to IEC 60947-1
[U _{imp}] rated impulse withstand voltage	2.5 kV conforming to IEC 60947-1
[I _{cm}] rated short-circuit making capacity	<= 0.1 kA at 600 V (DC-13) <= 0.27 kA at 250 V (DC-13) <= 0.55 kA at 125 V (DC-13) <= 12 kA at 600 V (AC-15) 7200 VA <= 15 kA at 480 V (AC-15) 7200 VA <= 30 kA at 240 V (AC-15) 7200 VA <= 60 kA at 120 V (AC-15) 7200 VA
Rated breaking capacity	<= 0.1 kA at 600 V (DC-13) <= 0.27 kA at 250 V (DC-13) <= 0.55 kA at 125 V (DC-13) <= 1.2 kA at 600 V (AC-15) 720 VA <= 1.5 kA at 480 V (AC-15) 720 VA <= 3 kA at 240 V (AC-15) 720 VA <= 6 kA at 120 V (AC-15) 720 VA
Light source	Incandescent
Bulb base	BA 9s
[U _s] rated supply voltage	24...28 V AC/DC
Operator additional information	Screw-on plastic mushroom
Device presentation	Complete product

Environment

protective treatment	TC
----------------------	----

The information provided in this documentation contains general descriptions and/or technical characteristics of the performance of the products contained herein. This documentation is not intended as a substitute for and is not to be used for determining suitability or reliability of these products for specific user applications. It is the duty of any such user or integrator to perform the appropriate and complete risk analysis, evaluation and testing of the products with respect to the relevant specific application or use thereof. Neither Schneider Electric Industries SAS nor any of its affiliates or subsidiaries shall be responsible or liable for misuse of the information contained herein.

ambient air temperature for storage	-40...158 °F (-40...70 °C)
ambient air temperature for operation	-13...158 °F (-25...70 °C)
electrical shock protection class	Class II conforming to IEC 60536
IP degree of protection	IP66 conforming to IEC 60529 IP66 conforming to NF C 20-010
NEMA degree of protection	NEMA 1 NEMA 12 NEMA 13 NEMA 2 NEMA 3 NEMA 3R NEMA 4 NEMA 4X
standards	EN/IEC 60947-5-1 IEC 60947-1 IEC 60947-5-4 JIS C 4520 JIS C 852 UL 508 CSA C22.2 No 14
vibration resistance	7 gn (f = 2...500 Hz) conforming to IEC 60068-2-6
shock resistance	50 gn conforming to IEC 60068-2-27

Offer Sustainability

785901665472	785901665472
Compliant - since 0921 - Schneider Electric declaration of conformity	Compliant - since 0921 - Schneider Electric declaration of conformity
Reference not containing SVHC above the threshold	Reference not containing SVHC above the threshold
WARNING: This product can expose you to chemicals including:	WARNING: This product can expose you to chemicals including:
Lead and lead compounds, which is known to the State of California to cause cancer and birth defects or other reproductive harm.	Lead and lead compounds, which is known to the State of California to cause cancer and birth defects or other reproductive harm.
For more information go to www.p65warnings.ca.gov	For more information go to www.p65warnings.ca.gov

Contractual warranty

Warranty period	18 months
-----------------	-----------

Dimensions

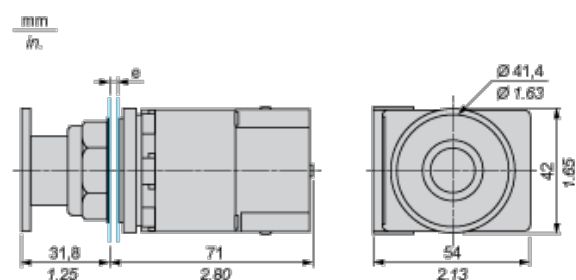

e panel thickness: 1 to 6 mm / 0.04 to 0.24 in.

Contact Block Mounting Position

Top and Rear views



- (1) It is possible to mount up to 3 levels of contacts blocks (maximum of 6 contacts blocks)
- (2) Operator
- (3) Locating notch
- (4) Side 1
- (5) Side 2



Компания «ЭлектроПласт» предлагает заключение долгосрочных отношений при поставках импортных электронных компонентов на взаимовыгодных условиях!

Наши преимущества:

- Оперативные поставки широкого спектра электронных компонентов отечественного и импортного производства напрямую от производителей и с крупнейших мировых складов;
- Поставка более 17-ти миллионов наименований электронных компонентов;
- Поставка сложных, дефицитных, либо снятых с производства позиций;
- Оперативные сроки поставки под заказ (от 5 рабочих дней);
- Экспресс доставка в любую точку России;
- Техническая поддержка проекта, помощь в подборе аналогов, поставка прототипов;
- Система менеджмента качества сертифицирована по Международному стандарту ISO 9001;
- Лицензия ФСБ на осуществление работ с использованием сведений, составляющих государственную тайну;
- Поставка специализированных компонентов (Xilinx, Altera, Analog Devices, Intersil, Interpoint, Microsemi, Aeroflex, Peregrine, Syfer, Eurofarad, Texas Instrument, Miteq, Cobham, E2V, MA-COM, Hittite, Mini-Circuits, General Dynamics и др.);

Помимо этого, одним из направлений компании «ЭлектроПласт» является направление «Источники питания». Мы предлагаем Вам помощь Конструкторского отдела:

- Подбор оптимального решения, техническое обоснование при выборе компонента;
- Подбор аналогов;
- Консультации по применению компонента;
- Поставка образцов и прототипов;
- Техническая поддержка проекта;
- Защита от снятия компонента с производства.



Как с нами связаться

Телефон: 8 (812) 309 58 32 (многоканальный)

Факс: 8 (812) 320-02-42

Электронная почта: org@eplast1.ru

Адрес: 198099, г. Санкт-Петербург, ул. Калинина, дом 2, корпус 4, литера А.