

## 0.5 AND 2.5 AMP ISODRIVERS WITH OPTO INPUT (2.5, 3.75, AND 5.0 kV<sub>RMS</sub>)

### Features

- Functional upgrade for HCPL-0302, HCPL-3120, TLP350, and similar opto-drivers
- 60 ns propagation delay max (independent of input drive current)
- 14x tighter part-to-part matching versus opto-drivers
- 2.5, 3.75, and 5.0 kV<sub>RMS</sub> isolation
- Transient Immunity
  - 30 kV/μs
- Under-voltage lockout protection with hysteresis
- Resistant to temperature and aging effects
- Gate driver supply voltage
  - 6.5 V to 24 V
- AEC-Q100 qualification
- Wide operating range
  - -40 to +125 °C
- RoHS-compliant packages
  - SOIC-8 narrow body
  - SOIC-16 wide body

### Applications

- IGBT/ MOSFET gate drives
- Industrial control systems
- Switch mode power supplies
- UPS systems
- Motor control drives
- Inverters

### Safety Regulatory Approvals

- UL 1577 recognized
  - Up to 5000 Vrms for 1 minute
- CSA component notice 5A approval
  - IEC 60950-1, 61010-1, 60601-1 (reinforced insulation)
- VDE certification conformity
  - IEC 60747-5-5 (VDE 0884 Part 5)
  - EN 60950-1 (reinforced insulation)
- CQC certification approval
  - GB4943.1

### Description

The Si8220/21 is a high-performance functional upgrade for opto-coupled drivers, such as the HCPL-3120 and the HPCL-0302 providing 2.5 A of peak output current. It utilizes Silicon Laboratories' proprietary silicon isolation technology, which provides a choice of 2.5, 3.75, or 5.0 kV<sub>RMS</sub> withstand voltages per UL1577. This technology enables higher performance, reduced variation with temperature and age, tighter part-to-part matching, and superior common-mode rejection compared to opto-isolated drivers. While the input circuit mimics the characteristics of an LED, less drive current is required, resulting in increased efficiency. Propagation delay time is independent of input drive current, resulting in consistently short propagation time, tighter unit-to-unit variation, and greater input circuit design flexibility.

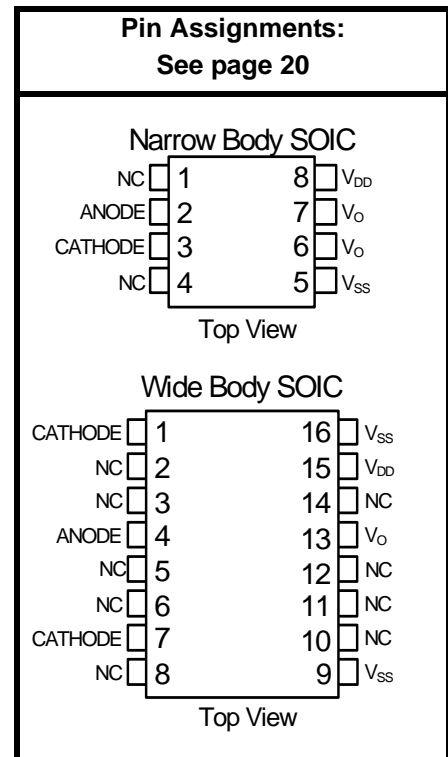

Patent pending

# Si8220/21

## Functional Block Diagram

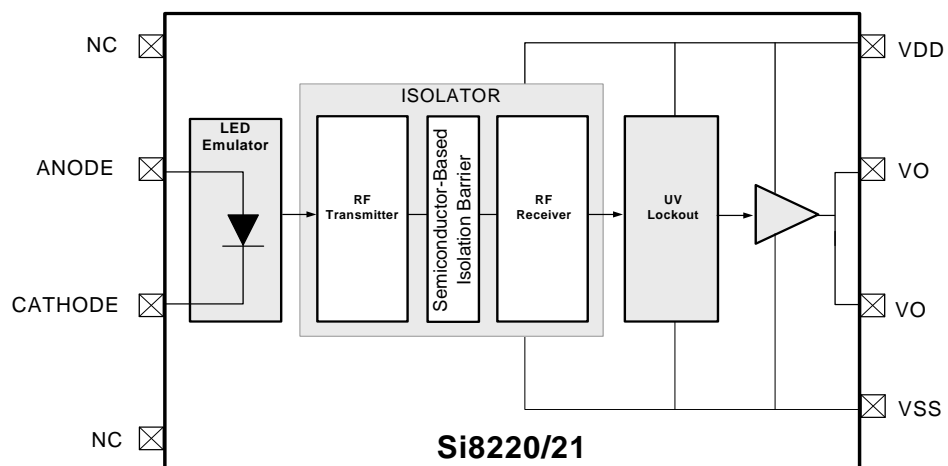

---

**TABLE OF CONTENTS**

---

<b><u>Section</u></b>	<b><u>Page</u></b>
<b>1. Electrical Specifications</b> .....	<b>4</b>
<b>2. Test Circuits</b> .....	<b>6</b>
<b>3. Regulatory Information</b> .....	<b>8</b>
<b>4. Functional Description</b> .....	<b>13</b>
4.1. Theory of Operation .....	13
<b>5. Technical Description</b> .....	<b>14</b>
5.1. Device Behavior .....	14
5.2. Device Startup .....	14
5.3. Under Voltage Lockout (UVLO) .....	15
<b>6. Applications</b> .....	<b>16</b>
6.1. Power Supply Connections .....	16
6.2. Layout Considerations .....	16
6.3. Power Dissipation Considerations .....	16
6.4. Input Circuit Design .....	17
6.5. Parametric Differences between Si8220/21 and HCPL-0302 and HCPL-3120 Opto Drivers .....	19
<b>7. Pin Descriptions (Narrow-Body SOIC)</b> .....	<b>20</b>
<b>8. Pin Descriptions (Wide-Body SOIC)</b> .....	<b>21</b>
<b>9. Ordering Guide</b> .....	<b>22</b>
<b>10. Package Outline: 8-Pin Narrow Body SOIC</b> .....	<b>23</b>
<b>11. Land Pattern: 8-Pin Narrow Body SOIC</b> .....	<b>24</b>
<b>12. Package Outline: 16-Pin Wide Body SOIC</b> .....	<b>25</b>
<b>13. Land Pattern: 16-Pin Wide-Body SOIC</b> .....	<b>27</b>
<b>14. Top Marking: 16-Pin Wide Body SOIC</b> .....	<b>28</b>
<b>15. Top Marking: 8-Pin Narrow Body SOIC</b> .....	<b>29</b>
<b>Document Change List</b> .....	<b>30</b>
<b>Contact Information</b> .....	<b>31</b>

## 1. Electrical Specifications

**Table 1. Electrical Characteristics** <sup>1</sup>

$V_{DD} = 12\text{ V or }15\text{ V}$ ,  $V_{SS} = \text{GND}$ ,  $T_A = -40\text{ to }+125\text{ }^\circ\text{C}$ ; typical specs at  $25\text{ }^\circ\text{C}$ .

Parameter	Symbol	Test Conditions	Min	Typ	Max	Units
<b>DC Specifications</b>						
Power Supply Voltage	$V_{DD}$	$(V_{DD} - V_{SS})$	6.5	—	24	V
Input Current (ON)	$I_{F(ON)}$		5.0	—	20	mA
Input Current Rising Edge Hysteresis	$I_{HYS}$		—	0.5	—	mA
Input Voltage (OFF)	$V_{F(OFF)}$	Measured at ANODE with respect to CATHODE.	-0.6	—	1.6	V
Input Forward Voltage	$V_F$	Measured at ANODE with respect to CATHODE. $I_F = 5\text{ mA}$ .	1.7	—	2.5	V
Output Resistance High (Source)	$R_{OH}$	0.5 A devices	—	15	—	$\Omega$
		2.5 A devices	—	2.7	—	
Output Resistance Low (Sink)	$R_{OL}$	0.5 A devices	—	5.0	—	
		2.5 A devices	—	1.0	—	
Output High Current (Source)	$I_{OH}$	(0.5 A), $I_F = 0$ (see Figure 2)	—	0.3	—	A
		(2.5 A), $I_F = 0$ (see Figure 2)	—	1.5	—	
Output Low Current (Sink)	$I_{OL}$	(0.5 A), $I_F = 10\text{ mA}$ , (see Figure 1)	—	0.5	—	A
		(2.5 A), $I_F = 10\text{ mA}$ , (see Figure 1)	—	2.5	—	
High-Level Output Voltage	$V_{OH}$	(0.5 A), $I_{OUT} = -50\text{ mA}$	—	$V_{DD} - 0.5$	—	V
		(2.5 A), $I_{OUT} = -50\text{ mA}$	—	$V_{DD} - 0.1$	—	
Low-Level Output Voltage	$V_{OL}$	(0.5 A), $I_{OUT} = 50\text{ mA}$	—	200	—	mV
		(2.5 A), $I_{OUT} = 50\text{ mA}$	—	50	—	
High-Level Supply Current		Output open $I_F = 10\text{ mA}$	—	1.2	—	mA
Low-Level Supply Current		Output open $V_F = -0.6\text{ to }+1.6\text{ V}$	—	1.4	—	mA
<b>Notes:</b>						
1. $V_{DD} = 12\text{ V}$ for 5, 8, and 10 V UVLO devices; $V_{DD} = 15\text{ V}$ for 12.5 V UVLO devices.						
2. See "9.Ordering Guide" on page 22 for more information.						

**Table 1. Electrical Characteristics (Continued)<sup>1</sup>**

$V_{DD} = 12\text{ V or }15\text{ V}$ ,  $V_{SS} = \text{GND}$ ,  $T_A = -40\text{ to }+125\text{ }^\circ\text{C}$ ; typical specs at  $25\text{ }^\circ\text{C}$ .

Parameter	Symbol	Test Conditions	Min	Typ	Max	Units
Input Reverse Voltage	$BV_R$	$I_R = 10\text{ mA}$ . Measured at ANODE with respect to CATHODE.	0.5	—	—	V
Input Capacitance	$C_{IN}$		—	10	—	pF
VDD Undervoltage Threshold <sup>2</sup>	$V_{DD_{UV+}}$	$V_{DD}$ rising				
5 V Threshold		See Figure 9 on page 15.	5.20	5.80	6.30	V
8 V Threshold		See Figure 10 on page 15.	7.50	8.60	9.40	V
10 V Threshold		See Figure 11 on page 15.	9.60	11.1	12.2	V
12.5 V Threshold		See Figure 12 on page 15.	12.4	13.8	14.8	
VDD Undervoltage Threshold <sup>2</sup>	$V_{DD_{UV-}}$	$V_{DD}$ falling				
5 V Threshold		See Figure 9 on page 15.	4.90	5.52	6.0	V
8 V Threshold		See Figure 10 on page 15.	7.20	8.10	8.70	V
10 V Threshold		See Figure 11 on page 15.	9.40	10.1	10.9	V
12.5 V Threshold		See Figure 12 on page 15.	11.6	12.8	13.8	
VDD Lockout Hysteresis	$V_{DD_{HYS}}$	UVLO voltage = 5 V	—	280	—	mV
VDD Lockout Hysteresis	$V_{DD_{HYS}}$	UVLO voltage = 8 V	—	600	—	mV
VDD Lockout Hysteresis	$V_{DD_{HYS}}$	UVLO voltage = 10 V or 12.5 V	—	1000	—	mV
<b>AC Specifications</b>						
Propagation Delay Time to High Output Level	$t_{PLH}$	$C_L = 200\text{ pF}$	—	—	60	ns
Propagation Delay Time to Low Output Level	$t_{PHL}$	$C_L = 200\text{ pF}$	—	—	40	ns
Output Rise and Fall Time	$t_R, t_F$	(0.5 A), $C_L = 200\text{ pF}$	—	—	30	ns
		(2.5 A), $C_L = 200\text{ pF}$	—	—	20	
Device Startup Time	$t_{START}$	Time from $V_{DD} = V_{DD_{UV+}}$ to $V_O$	—	—	40	$\mu\text{s}$
Common Mode Transient Immunity	CMTI	Input ON or OFF $V_{CM} = 1500\text{ V}$ (see Figure 3)	—	30	—	kV/ $\mu\text{s}$
<b>Notes:</b>						
1. $V_{DD} = 12\text{ V}$ for 5, 8, and 10 V UVLO devices; $V_{DD} = 15\text{ V}$ for 12.5 V UVLO devices.						
2. See "9.Ordering Guide" on page 22 for more information.						

## 2. Test Circuits

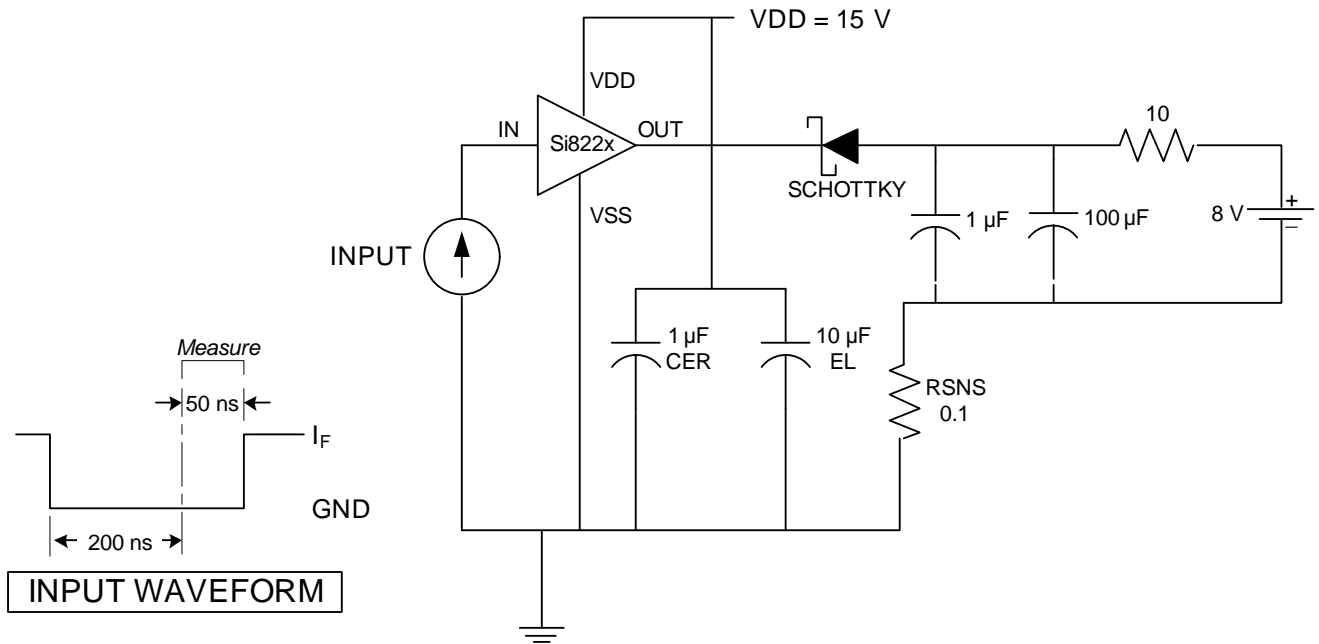

Figure 1. IOL Sink Current Test Circuit

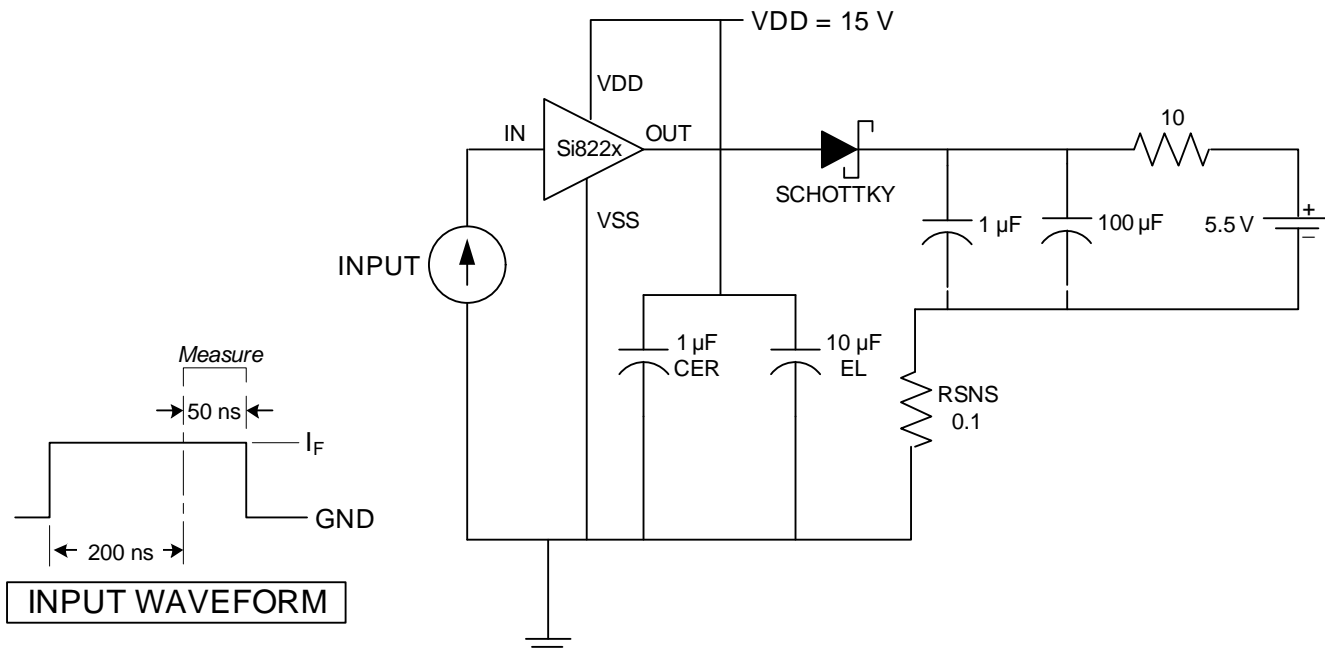

Figure 2. IOH Source Current Test Circuit

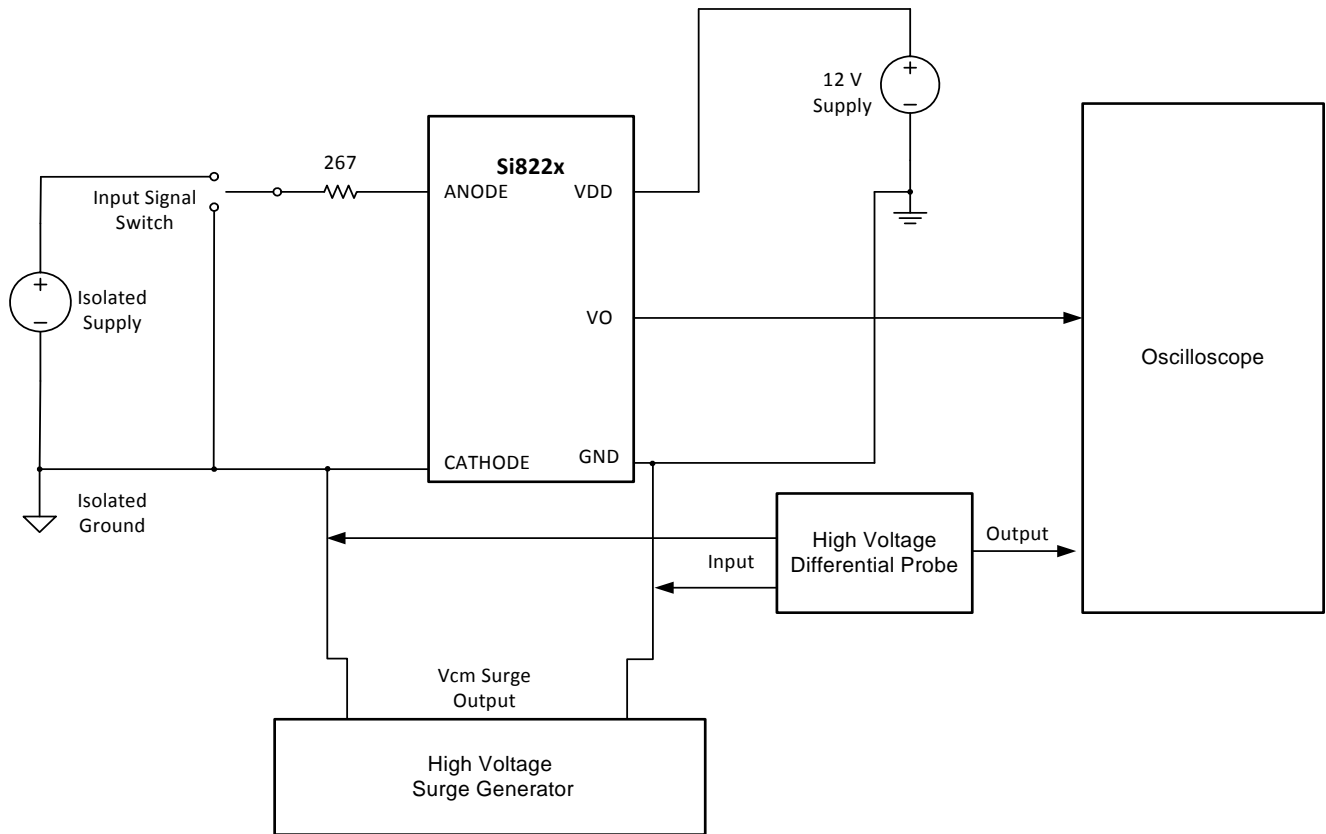

Figure 3. Common Mode Transient Immunity Test Circuit

## 3. Regulatory Information

Table 2. Regulatory Information\*

CSA
The Si822x is certified under CSA Component Acceptance Notice 5A. For more details, see File 232873.
61010-1: Up to 600 V <sub>RMS</sub> reinforced insulation working voltage; up to 600 V <sub>RMS</sub> basic insulation working voltage.
60950-1: Up to 600 V <sub>RMS</sub> reinforced insulation working voltage; up to 1000 V <sub>RMS</sub> basic insulation working voltage.
60601-1: Up to 125 V <sub>RMS</sub> reinforced insulation working voltage; up to 380 V <sub>RMS</sub> basic insulation working voltage.
VDE
The Si822x is certified according to IEC 60747-5-5. For more details, see File 5006301-4880-0001.
60747-5-5: Up to 891 V <sub>peak</sub> for basic insulation working voltage.
60950-1: Up to 600 V <sub>RMS</sub> reinforced insulation working voltage; up to 1000 V <sub>RMS</sub> basic insulation working voltage.
UL
The Si822x is certified under UL1577 component recognition program. For more details, see File E257455.
Rated up to 5000 V <sub>RMS</sub> isolation voltage for basic protection.
CQC
The Si822x is certified under GB4943.1-2011. For more details, see certificates CQC13001096107 and CQC13001096109.
Rated up to 600 V <sub>RMS</sub> reinforced insulation working voltage; up to 1000 V <sub>RMS</sub> basic insulation working voltage.
<b>*Note:</b> Regulatory Certifications apply to 2.5 kV <sub>RMS</sub> rated devices which are production tested to 3.0 kV <sub>RMS</sub> for 1 sec. Regulatory Certifications apply to 3.75 kV <sub>RMS</sub> rated devices which are production tested to 4.5 kV <sub>RMS</sub> for 1 sec. Regulatory Certifications apply to 5.0 kV <sub>RMS</sub> rated devices which are production tested to 6.0 kV <sub>RMS</sub> for 1 sec. For more information, see "9.Ordering Guide" on page 22.



Table 3. Insulation and Safety-Related Specifications

Parameter	Symbol	Test Condition	Value		Unit
			WB SOIC-16	NB SOIC-8	
Nominal Air Gap (Clearance) <sup>1</sup>	L(IO1)		8.0 min	4.9 min	mm
Nominal External Tracking (Creepage) <sup>1</sup>	L(IO2)		8.0 min	4.01 min	mm
Minimum Internal Gap (Internal Clearance)			0.014	0.014	mm
Tracking Resistance (Proof Tracking Index)	PTI	IEC60112	600	600	V
Erosion Depth	ED		0.019	0.019	mm
Resistance (Input-Output) <sup>2</sup>	R <sub>IO</sub>		10 <sup>12</sup>	10 <sup>12</sup>	Ω
Capacitance (Input-Output) <sup>2</sup>	C <sub>IO</sub>	f = 1 MHz	2.0	1.0	pF
Input Capacitance <sup>3</sup>	C <sub>I</sub>		4.0	4.0	pF

**Notes:**

1. The values in this table correspond to the nominal creepage and clearance values as detailed in "12.Package Outline: 16-Pin Wide Body SOIC" on page 25, "10.Package Outline: 8-Pin Narrow Body SOIC" on page 23. VDE certifies the clearance and creepage limits as 8.5 mm minimum for the WB SOIC-16 package and 4.7 mm minimum for the NB SOIC-8 package. UL does not impose a clearance and creepage minimum for component level certifications. CSA certifies the clearance and creepage limits as 3.9 mm minimum for the NB SOIC-8 and 7.6 mm minimum for the WB SOIC-16 package.
2. To determine resistance and capacitance, the Si822x is converted into a 2-terminal device. Pins 1–8 (1–4, NB SOIC-8) are shorted together to form the first terminal and pins 9–16 (5–8, NB SOIC-8) are shorted together to form the second terminal. The parameters are then measured between these two terminals.
3. Measured from input pin to ground.

**Table 4. IEC 60664-1 (VDE 0844 Part 5) Ratings**

Parameter	Test Conditions	Specification	
		NB SOIC8	WB SOIC 16
Basic Isolation Group	Material Group	I	I
Installation Classification	Rated Mains Voltages $\leq 150 V_{RMS}$	I-IV	I-IV
	Rated Mains Voltages $\leq 300 V_{RMS}$	I-III	I-IV
	Rated Mains Voltages $\leq 400 V_{RMS}$	I-II	I-III
	Rated Mains Voltages $\leq 600 V_{RMS}$	I-II	I-III

**Table 5. IEC 60747-5-5 Insulation Characteristics for Si822xxC\***

Parameter	Symbol	Test Condition	Characteristic		Unit
			WB SOIC-16	NB SOIC-8	
Maximum Working Insulation Voltage	$V_{IORM}$		891	560	V peak
Input to Output Test Voltage	$V_{PR}$	Method b1 ( $V_{IORM} \times 1.875 = V_{PR}$ , 100% Production Test, $t_m = 1$ sec, Partial Discharge $< 5$ pC)	1671	1050	V peak
Highest Allowable Overvoltage (Transient Overvoltage, $t_{TR} = 60$ sec)	$V_{TR}$		6000	4000	V peak
Pollution Degree (DIN VDE 0110, Table 1)			2	2	
Insulation Resistance at $T_S$ , $V_{IO} = 500$ V	$R_S$		$>10^9$	$>10^9$	$\Omega$

**\*Note:** This isolator is suitable for basic electrical isolation only within the safety limit data. Maintenance of the safety data is ensured by protective circuits. The Si822x provides a climate classification of 40/125/21.

Table 6. IEC Safety Limiting Values<sup>1</sup>

Parameter	Symbol	Test Condition	Max		Unit
			WB SOIC-16	NB SOIC-8	
Case Temperature	$T_S$		150	150	°C
Safety Input, Output, or Supply Current	$I_S$	$\theta_{JA} = 140$ °C/W (NB SOIC-8), 100 °C (WB SOIC-16), $V_I = 5.5$ V, $T_J = 150$ °C, $T_A = 25$ °C	50	40	mA
Device Power Dissipation <sup>2</sup>	$P_D$		1.2	1.2	W

**Notes:**

- Maximum value allowed in the event of a failure; also see the thermal derating curve in Figures 5 and 6.
- The Si822x is tested with  $V_O = 24$  V,  $T_J = 150$  °C,  $C_L = 200$  pF, input a 2 MHz 50% duty cycle square wave.

Table 7. Thermal Characteristics

Parameter	Symbol	Typ		Unit
		WB SOIC-16	NB SOIC-8	
IC Junction-to-Air Thermal Resistance	$\theta_{JA}$	100	140	°C/W

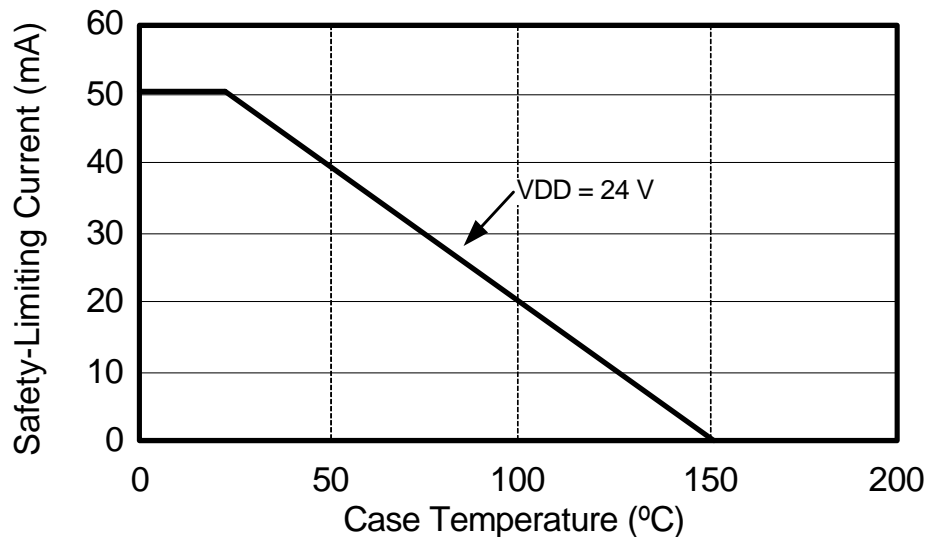
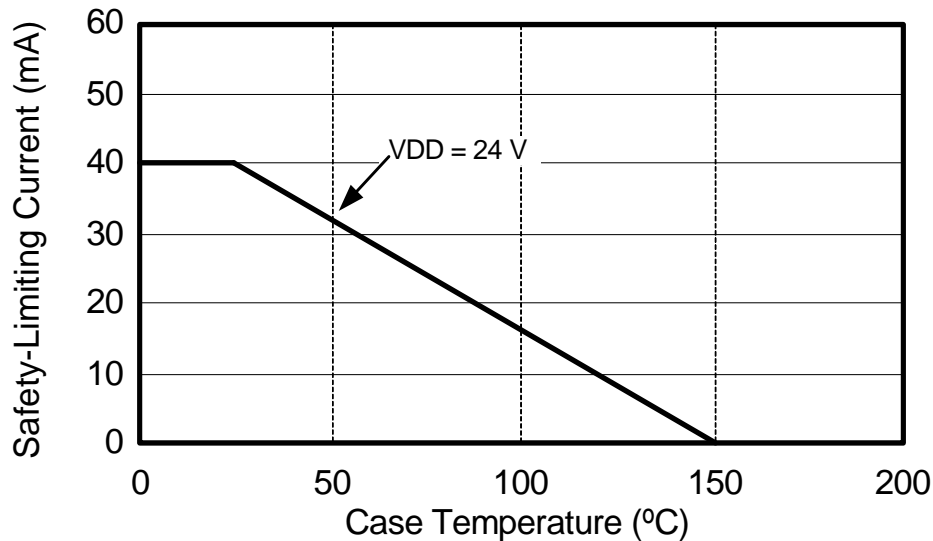

Figure 4. (WB SOIC-16) Thermal Derating Curve, Dependence of Safety Limiting Values with Case Temperature per DIN EN 60747-5-5



**Figure 5. (NB SOIC-8) Thermal Derating Curve, Dependence of Safety Limiting Values with Case Temperature per DIN EN 60747-5-5**

**Table 8. Absolute Maximum Ratings<sup>1</sup>**

Parameter	Conditions	Min	Max	Units
Storage Temperature <sup>2</sup>	$T_{STG}$	-65	+150	°C
Ambient Temperature under Bias	$T_A$	-40	+125	°C
Junction Temperature	$T_J$	—	150	°C
Input Current	$I_{F(AVG)}$	-100	30	mA
Driver-side Supply Voltage	$V_{DD}$	-0.6	30	V
Voltage on any output Pin with respect to Ground	$V_O$	-0.5	$V_{DD} + 0.5$	V
Peak Output Current ( $t_{PW} = 10 \mu s$ , duty cycle = 0.2%) (0.5 Amp versions)	$I_{OPK}$	—	0.5	A
Peak Output Current ( $t_{PW} = 10 \mu s$ , duty cycle = 0.2%) (4.0 Amp versions)	$I_{OPK}$	—	4.0	A
Lead Solder Temperature (10 s)		—	260	°C
Maximum Isolation Voltage (1 s) NB SOIC-8		—	4250	$V_{RMS}$
Maximum Isolation Voltage (1 s) WB SOIC-16		—	6500	$V_{RMS}$

**Notes:**

- Permanent device damage may occur if the absolute maximum ratings are exceeded. Functional operation should be restricted to the conditions specified in the operational sections of this data sheet.
- VDE certifies storage temperature from -40 to 150 °C.

## 4. Functional Description

### 4.1. Theory of Operation

The Si8220/21 is a functional upgrade for popular opto-isolated drivers, such as the Avago HPCL-3120, HPCL-0302, Toshiba TLP350, and others. The operation of an Si8220/21 channel is analogous to that of an opto coupler, except an RF carrier is modulated instead of light. This simple architecture provides a robust isolated data path and requires no special considerations or initialization at start-up. A simplified block diagram for the Si8220/21 is shown in Figure 6.

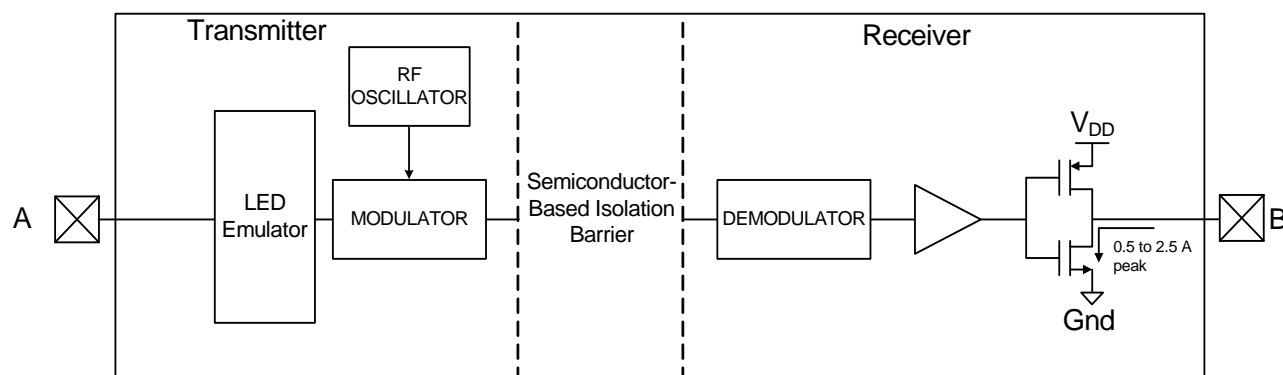

**Figure 6. Simplified Channel Diagram**

A channel consists of an RF Transmitter and RF Receiver separated by a semiconductor-based isolation barrier. Referring to the Transmitter, input A modulates the carrier provided by an RF oscillator using on/off keying. The Receiver contains a demodulator that decodes the input state according to its RF energy content and applies the result to output B via the output driver. This RF on/off keying scheme is superior to pulse code schemes as it provides best-in-class noise immunity, low power consumption, and better immunity to magnetic fields. See Figure 7 for more details.

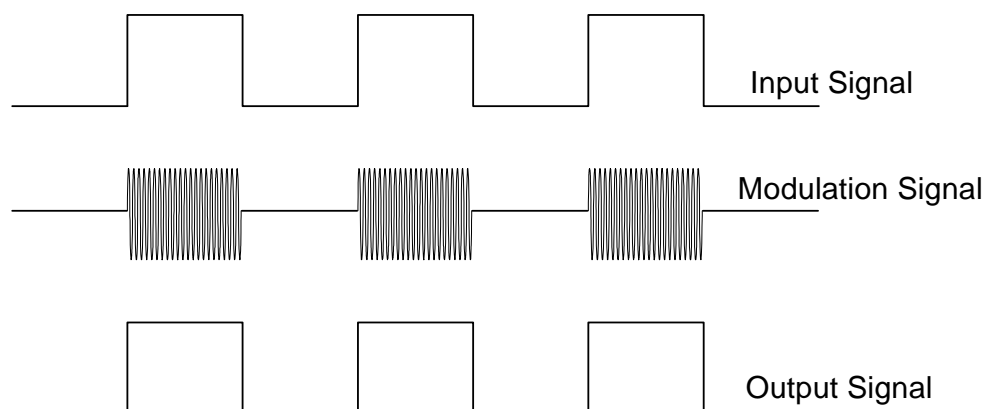

**Figure 7. Modulation Scheme**

## 5. Technical Description

### 5.1. Device Behavior

Truth tables for the Si8220/21 are summarized in Table 9.

**Table 9. Si8220/21 Truth Table Summary**

Cathode	Anode	Diode Current ( $I_F$ )	$V_{DD}$	$V_O$	Comments
X	X	X	< UVLO	L	Device turned off
Hi-Z	X	0	> UVLO	L	Logic low state
X	Hi-Z	0	> UVLO	L	Logic low state
GND	GND	0	> UVLO	L	Logic low state
VF	VF	0	> UVLO	L	Logic low state
GND1	VF	< $I_{F(OFF)}$	> UVLO	L	Logic low state
GND1	VF	$\geq I_{F(OFF)}$	> UVLO	H	Logic high state

**Note:** "X" = don't care. This truth table assumes  $V_{DD}$  is powered. If  $V_{DD}$  is below UVLO, see "5.3.Under Voltage Lockout (UVLO)" on page 15 for more information.

### 5.2. Device Startup

Output  $V_O$  is held low during power-up until  $V_{DD}$  rises above the UVLO+ threshold for a minimum time period of  $t_{START}$ . Following this, the output is high when the current flowing from anode to cathode is  $> I_{F(ON)}$ . Device startup, normal operation, and shutdown behavior is shown in Figure 8.

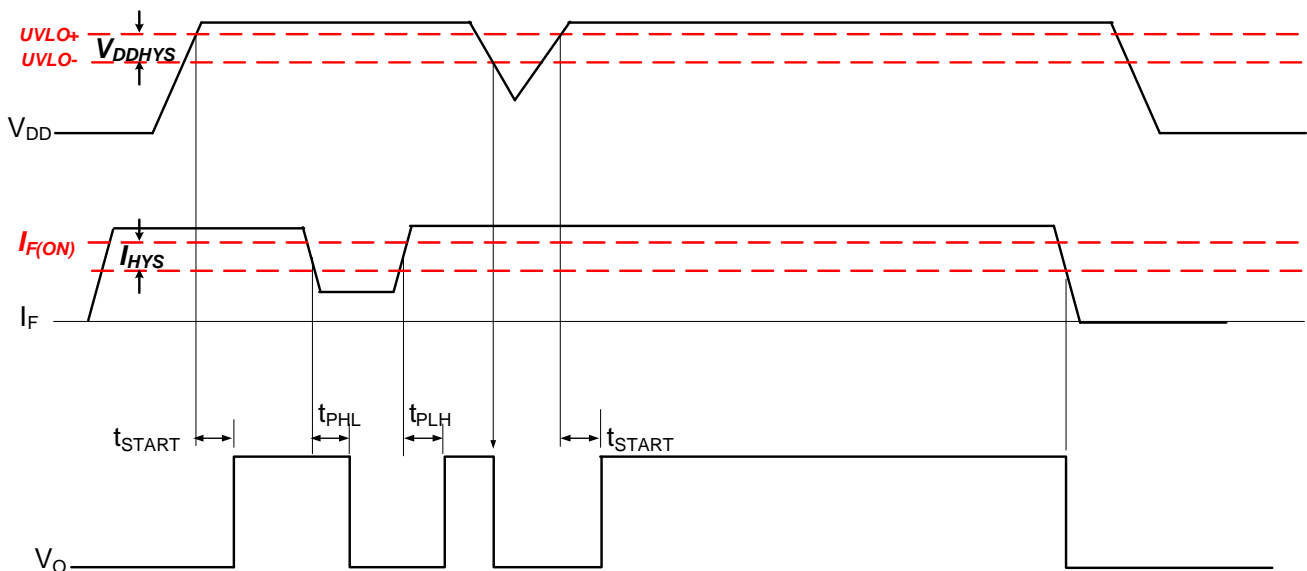

**Figure 8. Si8220/21 Operating Behavior ( $I_F \geq I_{F(MIN)}$  when  $V_F \geq V_{F(MIN)}$ )**

### 5.3. Under Voltage Lockout (UVLO)

The UVLO circuit unconditionally drives  $V_O$  low when  $V_{DD}$  is below the lockout threshold. Referring to Figures 9 through 12, upon power up, the Si8220/21 is maintained in UVLO until  $V_{DD}$  rises above  $V_{DD_{UV+}}$ . During power down, the Si8220/21 enters UVLO when  $V_{DD}$  falls below the UVLO threshold plus hysteresis (i.e.,  $V_{DD} \leq V_{DD_{UV+}} - V_{DD_{HYS}}$ ).

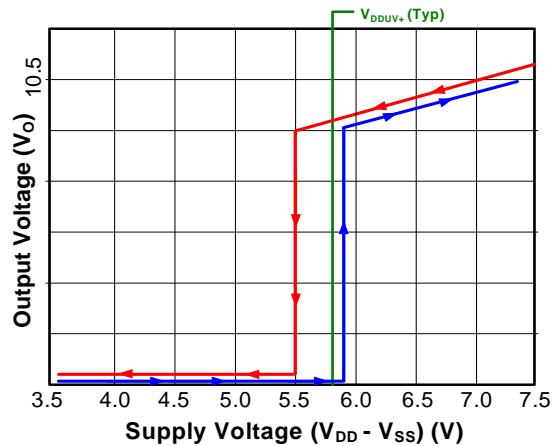

Figure 9. Si8220/21 UVLO Response (5 V)

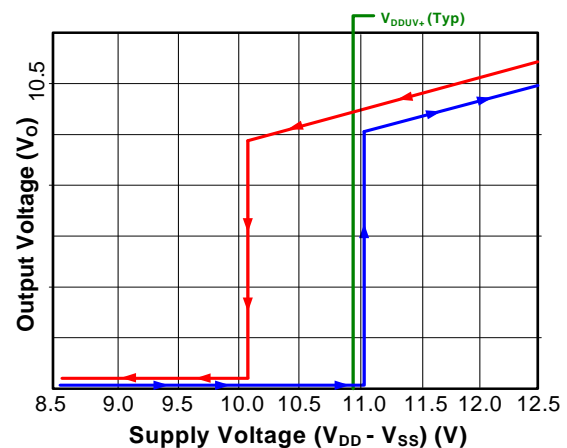

Figure 11. Si8220/21 UVLO Response (10 V)

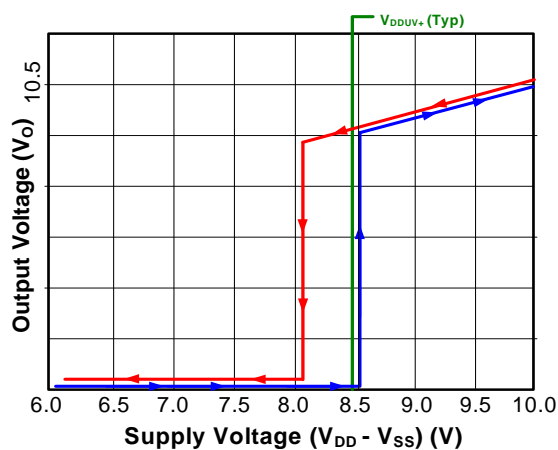

Figure 10. Si8220/21 UVLO Response (8 V)

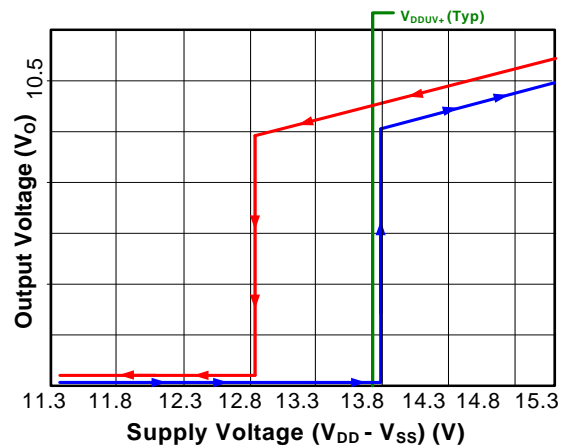

Figure 12. Si8220/21 UVLO Response (12.5 V)

## 6. Applications

### 6.1. Power Supply Connections

$V_{SS}$  can be biased at, above, or below ground as long as the voltage on  $V_{DD}$  with respect to  $V_{SS}$  is a maximum of 24 V.  $V_{DD}$  decoupling capacitors should be placed as close to the package pins as possible. The optimum values for these capacitors depend on load current and the distance between the chip and its power source. It is recommended that 0.1 and 10  $\mu$ F bypass capacitors be used to reduce high-frequency noise and maximize performance.

### 6.2. Layout Considerations

It is most important to minimize ringing in the drive path and noise on the  $V_{DD}$  lines. Care must be taken to minimize parasitic inductance in these paths by locating the Si8220/21 as close to the device it is driving as possible. In addition, the  $V_{DD}$  supply and ground trace paths must be kept short. For this reason, the use of power and ground planes is highly recommended. A split ground plane system having separate ground and  $V_{DD}$  planes for power devices and small signal components provides the best overall noise performance.

### 6.3. Power Dissipation Considerations

Proper system design must assure that the Si8220/21 operates within safe thermal limits across the entire load range. The Si8220/21 total power dissipation is the sum of the power dissipated by bias supply current, internal switching losses, and power delivered to the load, as shown in Equation 1.

$$P_D = (V_F)(I_F)(\text{Duty Cycle}) + (V_{DD})(I_{QOUT}) + (C_{int})(V_{DD}^2)(F) + (C_L)(V_{DD}^2)(F)$$

where:

$P_D$  is the total Si8220 device power dissipation (W)

$I_F$  is the diode current (20 mA max)

$V_F$  is the diode anode voltage (2.8 V max)

$I_{QOUT}$  is the driver maximum bias current (5 mA)

$C_{int}$  is the internal parasitic capacitance (370 pF)

$V_{DD}$  is the driver-side supply voltage (24 V max)

F is the switching frequency (Hz)

#### Equation 1.

The maximum allowable power dissipation for the Si8220/21 is a function of the package thermal resistance, ambient temperature, and maximum allowable junction temperature, as shown in Equation 2.

$$P_{Dmax} \leq \frac{T_{jmax} - T_A}{\theta_{ja}}$$

where:

$P_{Dmax}$  is the maximum allowable Si8220/21 power dissipation (W)

$T_{jmax}$  is the Si8220/21 maximum junction temperature (150 °C)

$T_A$  is the ambient temperature (°C)

$\theta_{ja}$  is the Si8220/21 package junction-to-air thermal resistance (125 °C/W)

#### Equation 2.

Substituting values for  $P_{Dmax}$ ,  $T_{jmax}$ ,  $T_A$ , and  $\theta_{ja}$  into Equation 2 results in a maximum allowable total power dissipation of 1.0 W. The maximum allowable load is found by substituting this limit and the appropriate datasheet values from Table 1 on page 4 into Equation 1 and simplifying. The result is Equation 3, where  $V_F = 2.8$  V,  $I_F = 10$  mA, and  $V_{DD} = 18$  V.



$$C_{L(max)} = \frac{1.35 \times 10^{-3}}{F} - 1.85 \times 10^{-10}$$

where:

$C_{L(max)}$  is the maximum load (pF) allowable at switching frequency F

### Equation 3.

A graph of Equation 3 is shown in Figure 13. Each point along the load line in this graph represents the package dissipation-limited value of  $C_L$  for the corresponding switching frequency.

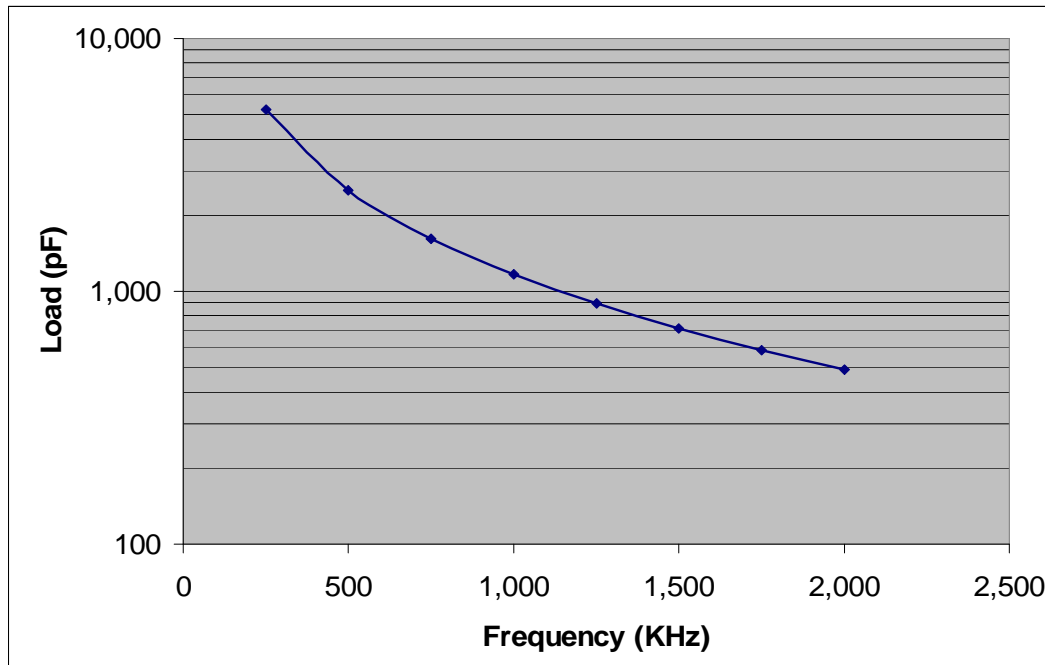

Figure 13. Maximum Load vs. Switching Frequency

## 6.4. Input Circuit Design

Opto driver manufacturers typically recommend the circuits shown in Figures 14 and 15. These circuits are specifically designed to improve opto-coupler input common-mode rejection and increase noise immunity.

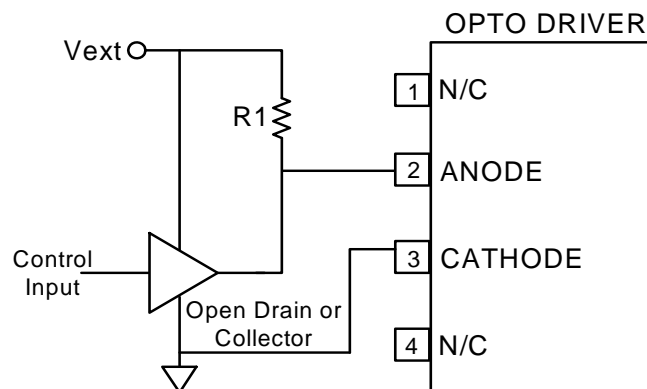
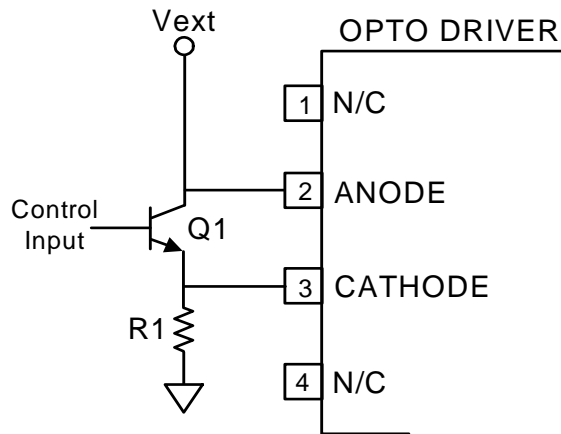

Figure 14. Opto Driver Input Circuit



**Figure 15. High CMR Opto Driver Input Circuit**

The optically-coupled driver circuit of Figure 14 turns the LED on when the control input is high. However, internal capacitive coupling from the LED to the power and ground conductors can momentarily force the LED into its off state when the anode and cathode inputs are subjected to a high common-mode transient. The circuit shown in Figure 15 addresses this issue by using a value of R1 sufficiently low to overdrive the LED, ensuring it remains on during an input common-mode transient. Q1 shorts the LED off in the low output state, again increasing common-mode transient immunity. Some opto driver applications also recommend reverse-biasing the LED when the control input is off to prevent coupled noise from energizing the LED.

The Si8220/21 can be used with the input circuits shown in Figures 14 and 15; however, some applications will require increasing the value of R1 in order to limit  $I_F$  to a maximum of 20 mA. The Si8220/21 propagation delay and output drive do not change for values of  $I_F$  between  $I_{F(MIN)}$  and  $I_{F(MAX)}$ . New designs should consider the input circuit configurations of Figure 16, which are more efficient than those of Figures 14 and 15. As shown, S1 represents any suitable switch, such as a BJT or MOSFET, analog transmission gate, processor I/O, etc. Also, note that the Si8220/21 input can be driven from the I/O port of any MCU or FPGA capable of sourcing a minimum of 5 mA (see Figure 16C).

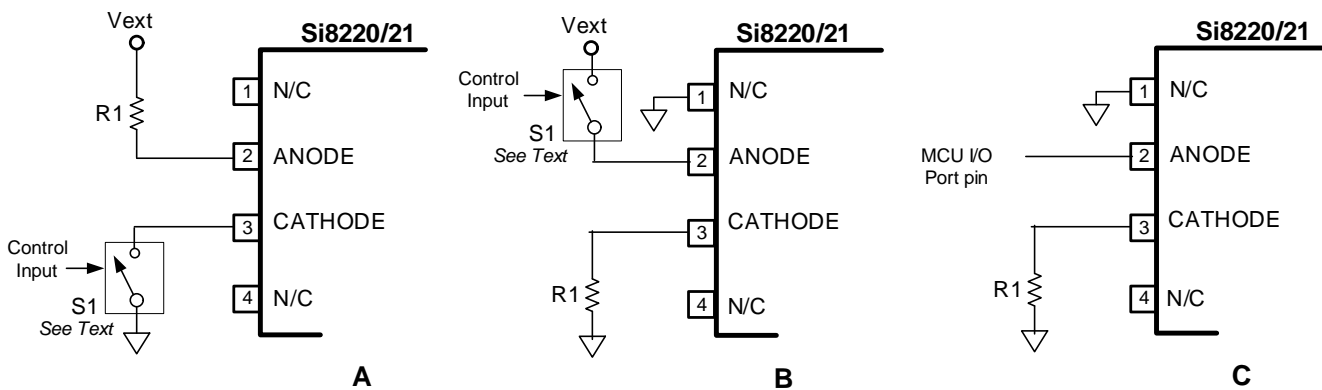

**Figure 16. Si8220/21 Other Input Circuit Configurations**

## 6.5. Parametric Differences between Si8220/21 and HCPL-0302 and HCPL-3120 Opto Drivers

The Si8220/21 is designed to directly replace HCPL-3120 and similar opto drivers. Parametric differences are summarized in Table 10 below.

**Table 10. Parametric Differences of Si8220 vs. HCPL-3120**

Parameter	Si8220	HCPL-3120	Units
Max supply voltage	24	30	V
ON state forward input current	5 to 20	7 to 16	mA
OFF state input voltage	-0.6 to +1.6	-0.3 to +0.8	V
Max reverse input voltage	0.5	-5	V
UVLO threshold (rising)	5.8 to 13.8	11.0 to 13.5	V
UVLO threshold (falling)	5.5 to 12.8	9.7 to 12.0	V
UVLO hysteresis	0.28 to 1	1.6	V
Rise/fall time into 10 $\Omega$ in series with 10 nF	20	100	ns

**Table 11. Parametric Differences of Si8221 vs. HCPL-0302**

Parameter	Si8221	HCPL-0302	Units
Max supply voltage	24	30	V
ON state forward input current	5 to 20	7 to 16	mA
OFF state input voltage	-0.6 to +1.6	-0.3 to +0.8	V
Max reverse input voltage	0.5	-5	V
UVLO threshold (rising)	5.8 to 13.8	11.0 to 13.5	V
UVLO threshold (falling)	5.5 to 12.8	9.7 to 12.0	V
UVLO hysteresis	0.28 to 1	1.6	V
Rise/fall time into 10 $\Omega$ in series with 10 nF	20	100	ns

### 6.5.1. Supply Voltage and UVLO

The supply voltage of the Si8220/21 is limited to 24 V, and the UVLO voltage thresholds are scaled accordingly. Opto replacement applications should limit their supply voltages to 24 V or less.

### 6.5.2. Input Diode Differences

The Si8220/21 input circuit requires less current and has twice the off-state noise margin compared to opto drivers. However, high CMR opto driver designs that overdrive the LED (see Figure 15) may require increasing the value of R1 to limit input current to 20 mA max. In addition, there is no benefit in driving the Si8220/21 input diode into reverse bias when in the off state. Consequently, opto driver circuits using this technique should either leave the negative bias circuitry unpopulated or modify the circuitry (e.g. add a clamp diode) to ensure that the anode pin of the Si8220/21 is no more than -0.8 V with respect to the cathode when reverse-biased.

# Si8220/21

## 7. Pin Descriptions (Narrow-Body SOIC)

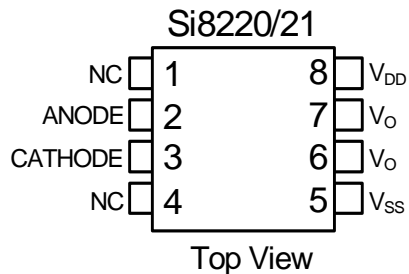
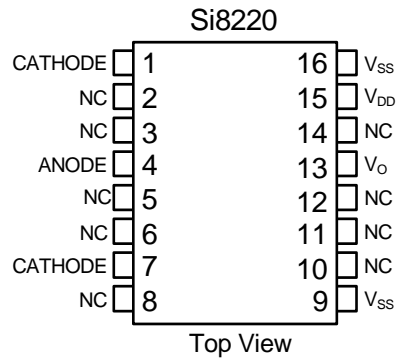

**Figure 17. Pin Configuration**

**Table 12. Pin Descriptions (Narrow-Body SOIC)**

Pin	Name	Description
1	NC	No connect.
2	ANODE	Anode of LED emulator. $V_O$ follows the signal applied to this input with respect to the CATHODE input.
3	CATHODE	Cathode of LED emulator. $V_O$ follows the signal applied to ANODE with respect to this input.
4	NC	No connect.
5	$V_{SS}$	External MOSFET source connection and ground reference for $V_{DD}$ . This terminal is typically connected to ground but may be tied to a negative or positive voltage.
6	$V_O$	Output signal. Pins 6 and 7 are connected together internally.
7	$V_O$	Output signal. Pins 6 and 7 are connected together internally.
8	$V_{DD}$	Output-side power supply input referenced to $V_{SS}$ (24 V max).
<p><b>*Note:</b> No Connect. These pins are not internally connected.</p>		

## 8. Pin Descriptions (Wide-Body SOIC)



**Table 13. Pin Descriptions (Wide-Body SOIC)**

Pin	Name	Description
1,7	CATHODE	Cathode of LED emulator. $V_O$ follows the signal applied to ANODE with respect to this input.
2,3,5,6,8, 10,11,12, 14	NC*	No connect.
4	ANODE	Anode of LED emulator. $V_O$ follows the signal applied to this input with respect to the CATHODE input.
9,16	$V_{SS}$	External MOSFET source connection and ground reference for $V_{DD}$ . This terminal is typically connected to ground but may be tied to a negative or positive voltage.
13	$V_O$	Output signal.
15	$V_{DD}$	Output-side power supply input referenced to $V_{SS}$ (24 V max).
*Note: No Connect. These pins are not internally connected.		

## 9. Ordering Guide

Table 14. Si8220/21 Ordering Guide\*

New Ordering Part Number (OPN)	Ordering Options					
	Input Configuration	Peak Output Current (Cross Reference)	UVLO Voltage	Insulation Rating	Temp Range	Pkg Type
Si8220BB-D-IS	Opto input	2.5 A (HCPL-3120)	8 V default	2.5 kVrms	-40 to +125 °C	SOIC-8
Si8220CB-D-IS	Opto input	2.5 A (HCPL-3120)	10 V	2.5 kVrms	-40 to +125 °C	SOIC-8
Si8220DB-D-IS	Opto input	2.5 A (HCPL-3120)	12.5 V	2.5 kVrms	-40 to +125 °C	SOIC-8
Si8220BD-D-IS	Opto input	2.5 A (HCPL-3120)	8 V default	5.0 kVrms	-40 to +125 °C	WB SOIC-16
Si8220CD-D-IS	Opto input	2.5 A (HCPL-3120)	10 V	5.0 kVrms	-40 to +125 °C	WB SOIC-16
Si8220DD-D-IS	Opto input	2.5 A (HCPL-3120)	12.5 V	5.0 kVrms	-40 to +125 °C	WB SOIC-16
Si8221CC-D-IS	Opto input	0.5 A (HCPL-0302)	10 V	3.75 kVrms	-40 to +125 °C	SOIC-8
Si8221DC-D-IS	Opto input	0.5 A (HCPL-0302)	12.5 V	3.75 kVrms	-40 to +125 °C	SOIC-8

**\*Note:** All packages are RoHS-compliant with peak reflow temperatures of 260 °C according to the JEDEC industry standard classifications and peak solder temperatures.  
All devices are AEC-Q100 qualified.  
“Si” and “SI” are used interchangeably.

## 10. Package Outline: 8-Pin Narrow Body SOIC

Figure 18 illustrates the package details for the Si822x. Table 15 lists the values for the dimensions shown in the illustration.

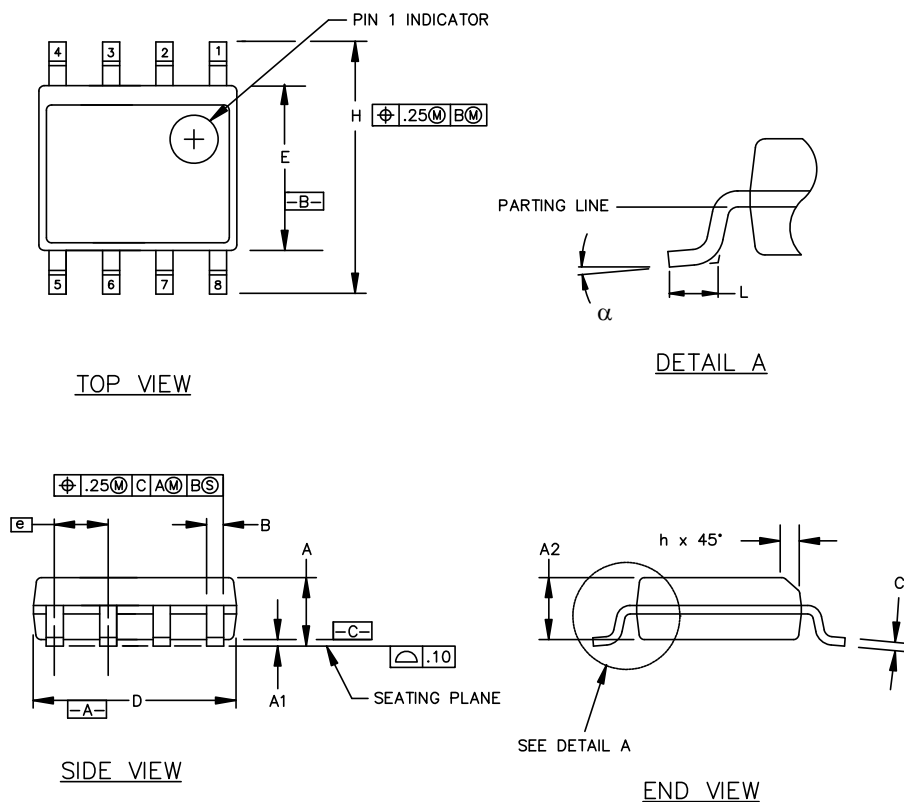

Figure 18. 8-pin Small Outline Integrated Circuit (SOIC) Package

Table 15. Package Diagram Dimensions

Symbol	Millimeters	
	Min	Max
A	1.35	1.75
A1	0.10	0.25
A2	1.40 REF	1.55 REF
B	0.33	0.51
C	0.19	0.25
D	4.80	5.00
E	3.80	4.00
e	1.27 BSC	
H	5.80	6.20
h	0.25	0.50
L	0.40	1.27
$\alpha$	0°	8°

## 11. Land Pattern: 8-Pin Narrow Body SOIC

Figure 19 illustrates the recommended land pattern details for the Si822x in an 8-pin narrow-body SOIC. Table 16 lists the values for the dimensions shown in the illustration.

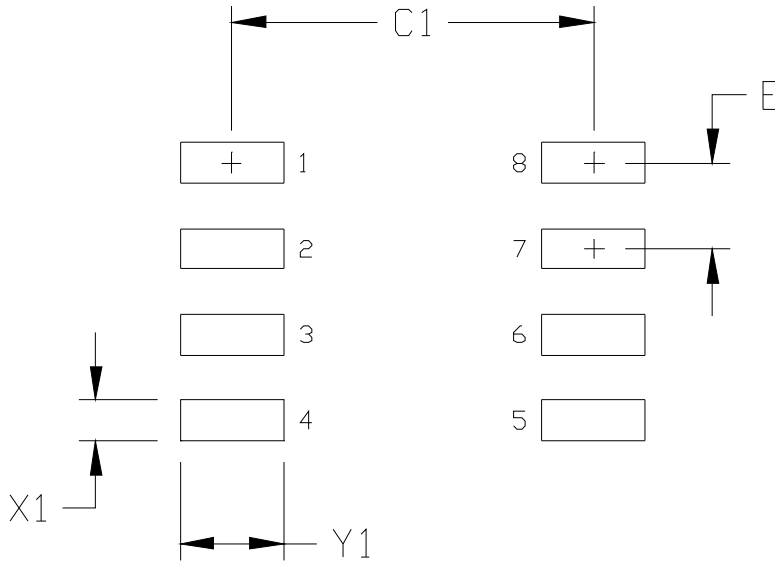

**Figure 19. PCB Land Pattern: 8-Pin Narrow Body SOIC**

**Table 16. PCM Land Pattern Dimensions (8-Pin Narrow Body SOIC)**

Dimension	Feature	(mm)
C1	Pad Column Spacing	5.40
E	Pad Row Pitch	1.27
X1	Pad Width	0.60
Y1	Pad Length	1.55
<b>Notes:</b>		
<ol style="list-style-type: none"> <li>1. This Land Pattern Design is based on IPC-7351 pattern SOIC127P600X173-8N for Density Level B (Median Land Protrusion).</li> <li>2. All feature sizes shown are at Maximum Material Condition (MMC) and a card fabrication tolerance of 0.05 mm is assumed.</li> </ol>		



## 12. Package Outline: 16-Pin Wide Body SOIC

Figure 20 illustrates the package details for the Si822x Digital Isolator. Table 17 lists the values for the dimensions shown in the illustration.

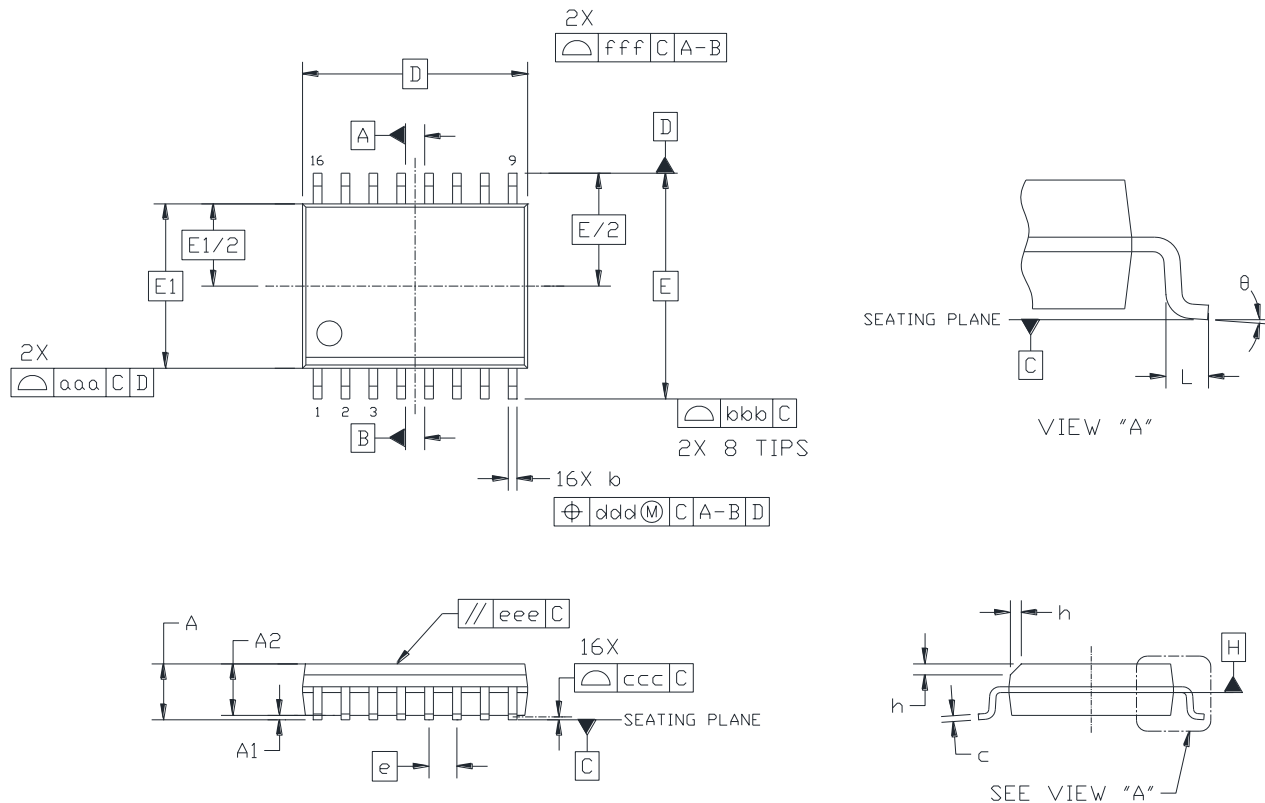

Figure 20. 16-Pin Wide Body SOIC

Table 17. Package Diagram Dimensions

Dimension	Min	Max
A	—	2.65
A1	0.10	0.30
A2	2.05	—
b	0.31	0.51
c	0.20	0.33
D	10.30 BSC	
E	10.30 BSC	
E1	7.50 BSC	
e	1.27 BSC	
L	0.40	1.27
h	0.25	0.75
$\theta$	0°	8°
aaa	—	0.10
bbb	—	0.33
ccc	—	0.10
ddd	—	0.25
eee	—	0.10
fff	—	0.20
<b>Notes:</b>		
<ol style="list-style-type: none"> <li>1. All dimensions shown are in millimeters (mm) unless otherwise noted.</li> <li>2. Dimensioning and Tolerancing per ANSI Y14.5M-1994.</li> <li>3. This drawing conforms to JEDEC Outline MS-013, Variation AA.</li> <li>4. Recommended reflow profile per JEDEC J-STD-020C specification for small body, lead-free components.</li> </ol>		

### 13. Land Pattern: 16-Pin Wide-Body SOIC

Figure 21 illustrates the recommended land pattern details for the Si822x in a 16-pin wide-body SOIC. Table 18 lists the values for the dimensions shown in the illustration.

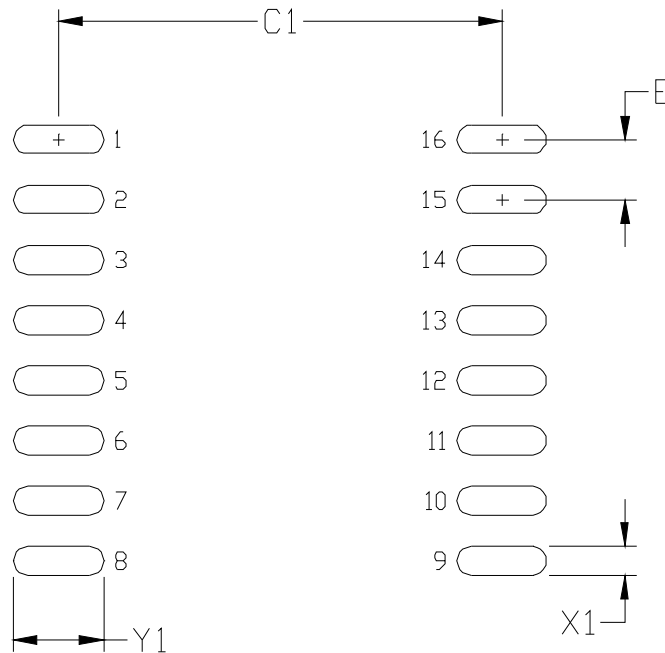

Figure 21. 16-Pin SOIC Land Pattern

Table 18. 16-Pin Wide Body SOIC Land Pattern Dimensions

Dimension	Feature	(mm)
C1	Pad Column Spacing	9.40
E	Pad Row Pitch	1.27
X1	Pad Width	0.60
Y1	Pad Length	1.90

**Notes:**

1. This Land Pattern Design is based on IPC-7351 pattern SOIC127P1032X265-16AN for Density Level B (Median Land Protrusion).
2. All feature sizes shown are at Maximum Material Condition (MMC) and a card fabrication tolerance of 0.05 mm is assumed.

## 14. Top Marking: 16-Pin Wide Body SOIC

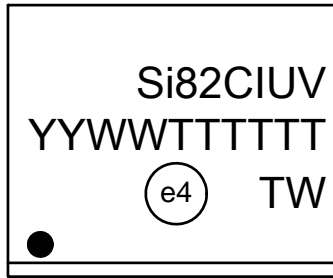

Figure 22. 16-Pin Wide Body SOIC Top Marking

Table 19. 16-Pin Wide Body SOIC Top Marking Explanation

<b>Line 1 Marking:</b>	Base Part Number Ordering Options See Ordering Guide for more information.	Si82 = ISOdriver product series C = Input configuration 2 = Opto input type I = Peak output current 0 = 2.5A; 1 = 0.5A U = UVLO level A = 5 V; B = 8 V; C = 10 V; D = 12.5 V V = Isolation rating A = 1 kV; B = 2.5 kV; C = 3.75 kV D = 5.0 kV
	<b>Line 2 Marking:</b>	
	YY = Year WW = Workweek	Assigned by the Assembly House. Corresponds to the year and workweek of the mold date.
	TTTTTT = Mfg Code	Manufacturing Code from Assembly Purchase Order form.
<b>Line 3 Marking:</b>	Circle = 1.5 mm Diameter (Center Justified)	"e4" Pb-Free Symbol
	Country of Origin ISO Code Abbreviation	TW = Taiwan

## 15. Top Marking: 8-Pin Narrow Body SOIC

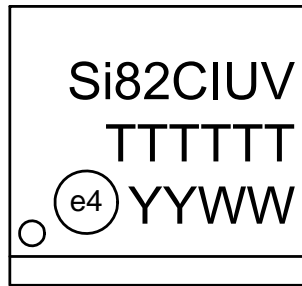

Figure 23. 8-Pin Narrow Body SOIC Top Marking

Table 20. 8-Pin Narrow Body SOIC Top Marking Explanations

<b>Line 1 Marking:</b>	Base Part Number Ordering Options (See Ordering Guide for more information)	Si82 = ISOdriver product series C = Input configuration 2 = Opto input type I = Peak output current 0 = 2.5 A; 1 = 0.5 A U = UVLO level A = 5 V; B = 8 V; C = 10 V; D = 12.5 V V = Isolation rating A = 1 = kV; B = 2.5 = kV; C = 3.75 kV D = 5.0 kV
<b>Line 2 Marking:</b>	TTTTTT	Manufacturing date code assigned by assembly contractor.
<b>Line 3 Marking:</b>	Circle = 1.1 mm Diameter Left-Justified	"e4" Pb-Free Symbol

## DOCUMENT CHANGE LIST

### Revision 0.22 to Revision 1.0

- Updated Tables 2, 3, 4, and 5.
- Updated "9. Ordering Guide" .
- Added Device Marking sections.

### Revision 1.0 to Revision 1.1

- Updated Table 5 on page 10.
- Updated Table 8 on page 12.
- Removed introductory text and Figure 17.
- Changed all packages to MSL2A in "9.Ordering Guide" on page 22.
- Updated "12.Package Outline: 16-Pin Wide Body SOIC" on page 25.

### Revision 1.1 to Revision 1.2

- Updated CMTI spec in Table 1 on page 4.
- Updated Figure 1 on page 6.
- Updated Figure 2 on page 6.
- Added Figure 3 on page 7.
- Updated Table 5 on page 10.
- Added note to Table 14 on page 22.

### Revision 1.2 to Revision 1.3

- Added references to AEC-Q100 throughout.
- Changed all 60747-5-2 references to 60747-5-5.
- Added references to CQC throughout.
- Removed all references to moisture sensitivity level.

### Revision 1.3 to Revision 1.4

- Updated Table 14, Ordering Part Numbers.
  - Added Revision D Ordering Part Numbers.
  - Removed all Ordering Part Numbers of previous revisions.

### Revision 1.4 to Revision 1.5

- Updated Table 2 on page 8.
  - Added CQC certificate numbers.
- Updated Table 3 on page 9.
  - Updated Erosion Depth specification.
- Updated Table 8 on page 12.
  - Replaced  $I_O$  with Peak Output Current  $I_{OPK}$ .
  - Added  $T_J$  specification in Table 8 on page 12.
- Updated Figure 14 on page 17.
- Updated Figure 15 on page 18.
- Updated Figure 16 on page 18.
- Updated "9.Ordering Guide" on page 22.
  - Updated AEC-Q100 note.

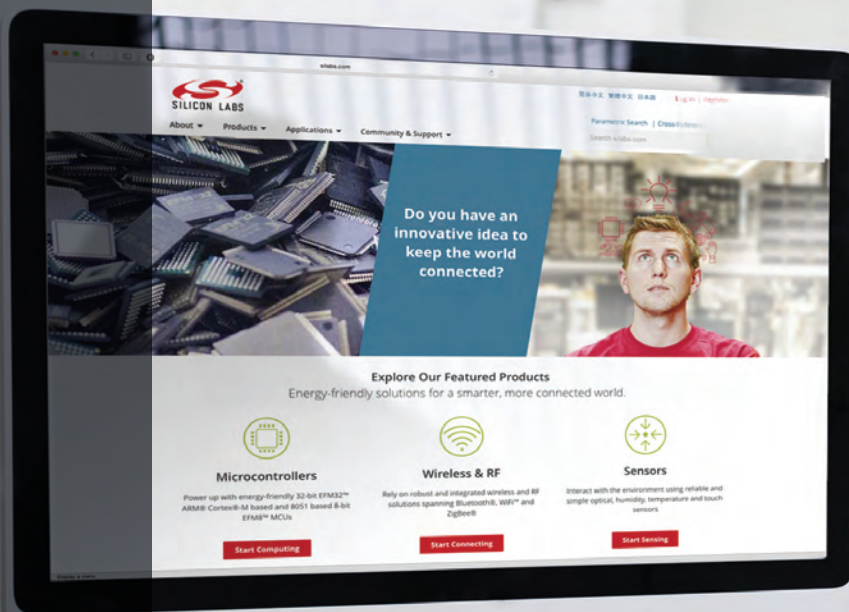

Smart.  
Connected.  
Energy-Friendly



**Products**  
[www.silabs.com/products](http://www.silabs.com/products)

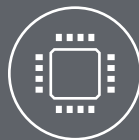

**Quality**  
[www.silabs.com/quality](http://www.silabs.com/quality)



**Support and Community**  
[community.silabs.com](http://community.silabs.com)

#### Disclaimer

Silicon Laboratories intends to provide customers with the latest, accurate, and in-depth documentation of all peripherals and modules available for system and software implementers using or intending to use the Silicon Laboratories products. Characterization data, available modules and peripherals, memory sizes and memory addresses refer to each specific device, and "Typical" parameters provided can and do vary in different applications. Application examples described herein are for illustrative purposes only. Silicon Laboratories reserves the right to make changes without further notice and limitation to product information, specifications, and descriptions herein, and does not give warranties as to the accuracy or completeness of the included information. Silicon Laboratories shall have no liability for the consequences of use of the information supplied herein. This document does not imply or express copyright licenses granted hereunder to design or fabricate any integrated circuits. The products must not be used within any Life Support System without the specific written consent of Silicon Laboratories. A "Life Support System" is any product or system intended to support or sustain life and/or health, which, if it fails, can be reasonably expected to result in significant personal injury or death. Silicon Laboratories products are generally not intended for military applications. Silicon Laboratories products shall under no circumstances be used in weapons of mass destruction including (but not limited to) nuclear, biological or chemical weapons, or missiles capable of delivering such weapons.

#### Trademark Information

Silicon Laboratories Inc., Silicon Laboratories, Silicon Labs, SiLabs and the Silicon Labs logo, CMEMS®, EFM, EFM32, EFR, Energy Micro, Energy Micro logo and combinations thereof, "the world's most energy friendly microcontrollers", Ember®, EZLink®, EZMac®, EZRadio®, EZRadioPRO®, DSPLL®, ISOmodem®, Precision32®, ProSLIC®, SiPHY®, USBXpress® and others are trademarks or registered trademarks of Silicon Laboratories Inc. ARM, CORTEX, Cortex-M3 and THUMB are trademarks or registered trademarks of ARM Holdings. Keil is a registered trademark of ARM Limited. All other products or brand names mentioned herein are trademarks of their respective holders.



Silicon Laboratories Inc.  
400 West Cesar Chavez  
Austin, TX 78701  
USA

<http://www.silabs.com>



Компания «ЭлектроПласт» предлагает заключение долгосрочных отношений при поставках импортных электронных компонентов на взаимовыгодных условиях!

Наши преимущества:

- Оперативные поставки широкого спектра электронных компонентов отечественного и импортного производства напрямую от производителей и с крупнейших мировых складов;
- Поставка более 17-ти миллионов наименований электронных компонентов;
- Поставка сложных, дефицитных, либо снятых с производства позиций;
- Оперативные сроки поставки под заказ (от 5 рабочих дней);
- Экспресс доставка в любую точку России;
- Техническая поддержка проекта, помощь в подборе аналогов, поставка прототипов;
- Система менеджмента качества сертифицирована по Международному стандарту ISO 9001;
- Лицензия ФСБ на осуществление работ с использованием сведений, составляющих государственную тайну;
- Поставка специализированных компонентов (Xilinx, Altera, Analog Devices, Intersil, Interpoint, Microsemi, Aeroflex, Peregrine, Syfer, Eurofarad, Texas Instrument, Miteq, Cobham, E2V, MA-COM, Hittite, Mini-Circuits, General Dynamics и др.);

Помимо этого, одним из направлений компании «ЭлектроПласт» является направление «Источники питания». Мы предлагаем Вам помощь Конструкторского отдела:

- Подбор оптимального решения, техническое обоснование при выборе компонента;
- Подбор аналогов;
- Консультации по применению компонента;
- Поставка образцов и прототипов;
- Техническая поддержка проекта;
- Защита от снятия компонента с производства.



#### Как с нами связаться

**Телефон:** 8 (812) 309 58 32 (многоканальный)

**Факс:** 8 (812) 320-02-42

**Электронная почта:** [org@eplast1.ru](mailto:org@eplast1.ru)

**Адрес:** 198099, г. Санкт-Петербург, ул. Калинина, дом 2, корпус 4, литера А.