

## Analog Signal Input Stereo Class D Power Amplifier

### ■ GENERAL DESCRIPTION

The **NJU8755** is an analog signal input stereo class D power amplifier. The **NJU8755** includes inversion operational amplifier input circuit, PWM modulators, an output-short protector and a low voltage detector. The **NJU8755** incorporates BTL amplifiers, which eliminate AC coupling capacitors, capable of driving up to 1.2W/channel with simple external LC low-pass filters.

Class-D operation achieves high power-efficiency, which achieves longer battery life for battery powered applications, thus the **NJU8755** is suited for portable audio, note-PC, etc.

### ■ PACKAGE OUTLINE

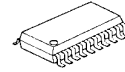

**NJU8755V**

### ■ FEATURES

- 2-Channel Analog Signal Input
- 2-Channel BTL Outputs :1.2W/channel at 5V into 8Ω
- Standby(Hi-Z), Mute Control
- Built-in Short Protector
- Built-in Low Voltage Detector
- Operating Voltage 2.7 to 5.25V
- CMOS Technology
- Package Outline SSOP20

### ■ PIN CONFIGURATION

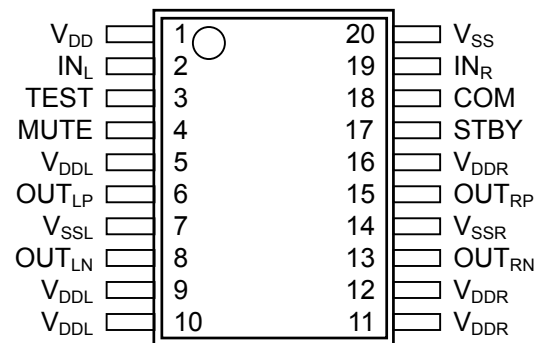

### ■ BLOCK DIAGRAM

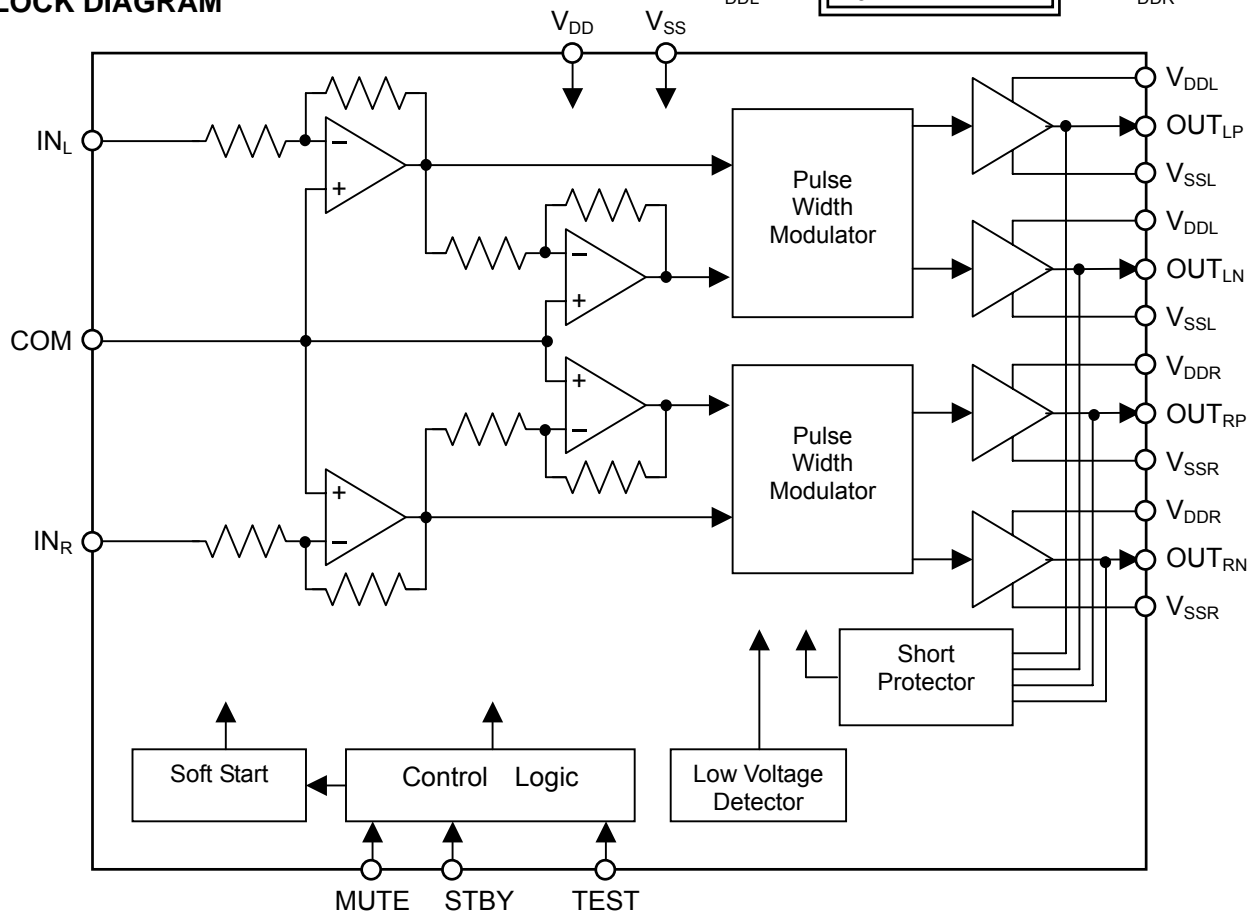

## ■ PIN DESCRIPTION

No.	SYMBOL	I/O	FUNCTION
1	$V_{DD}$	–	Power Supply : $V_{DD}=5.0V$
2	$IN_L$	I	L-channel signal input
3	TEST	I	Maker test This pin must be connected to GND.
4	MUTE	I	Mute control Low : Mute ON High : Mute OFF
5 9 10	$V_{DDL}$	–	L-channel Power Supply : $V_{DDL}=5.0V$
6	$OUT_{LP}$	O	L-channel positive output
7	$V_{SSL}$	–	L-channel Power GND
8	$OUT_{LN}$	O	L-channel negative output
11 12 16	$V_{DDR}$	–	R-channel Power Supply : $V_{DDR}=5.0V$
13	$OUT_{RN}$	O	R-channel negative output
14	$V_{SSR}$	–	R-channel Power GND : $V_{SSR}=0V$
15	$OUT_{RP}$	O	R-channel positive output
17	STBY	I	Standby control Low : Standby ON High : Standby OFF
18	COM	–	Analog common
19	$IN_R$	I	R-channel signal input
20	$V_{SS}$	–	Power GND : $V_{SS}=0V$

\*The relations of " $V_{SS}=V_{SSL}=V_{SSR}=0V$ " and " $V_{DD}=V_{DDL}=V_{DDR}$ " must be maintained.

\*Pin No.4(MUTE) and 17(STBY) must be connected to  $V_{DD}$ , when these pins are not used.

## ■ FUNCTIONAL DESCRIPTION

### (1) Signal Output

The  $OUT_{LP/LN}$  and  $OUT_{RP/RN}$  generate respectively L-channel and R-channel PWM output signals, which will be converted to analog signal via external 2nd-order or higher LC filter. A switching regulator with a high response against a voltage fluctuation is the best selection for the  $V_{DDL}$  and  $V_{DDR}$ , which are the power supply for output drivers. To obtain better THD performance, the stabilization of the power is required.

### (2) Standby

By setting the STBY pin to "L", the standby mode is enabled. In the standby mode, the entire functions of the **NJU8755** enter a low-power state, and the output pins( $OUT_{LP/LN}$  and  $OUT_{RP/RN}$ ) are high impedance.

### (3) Mute

By setting the MUTE pin to "L", the Mute function is enabled. In the Mute mode, the output pins( $OUT_{LP/LN}$  and  $OUT_{RP/RN}$ ) output square wave(Duty: 50%).

### (4) Low Voltage Detector

When the power supply voltage drops down to below  $V_{DD}(\text{MIN})$ , the internal oscillation is halted for prevention to generate unwanted frequency, and the output pins( $OUT_{LP/LN}$  and  $OUT_{RP/RN}$ ) become in high impedance.

### (5) Short Circuit Protection

The short protector, which protects the **NJU8755** against high short-circuit current, turns off the output drivers of L-channel and R-channel independently. After about 5 seconds from the protection, the **NJU8755** returns to normal operation. The short protector functions at following accidents.

- Short between  $OUT_{LP}$  and  $OUT_{LN}$
- Short between  $OUT_{LP}$  and  $V_{SSL}$
- Short between  $OUT_{LN}$  and  $V_{SSL}$
- Short between  $OUT_{RP}$  and  $OUT_{RN}$
- Short between  $OUT_{RP}$  and  $V_{SSR}$
- Short between  $OUT_{RN}$  and  $V_{SSR}$

Note 1) The detectable current and the period for the protection depend on the power supply voltage and ambient temperature.

Note 2) The short protector is not effective for a long term short-circuit but for an instantaneous accident. Continuous high-current may cause permanent damage to **NJU8755**.

## ■ ABSOLUTE MAXIMUM RATINGS

(Ta=25°C)

PARAMETER	SYMBOL	RATING	UNIT
Supply Voltage	V <sub>DD</sub>	-0.3 ~ +5.5	V
	V <sub>DDL</sub>	-0.3 ~ +5.5	V
	V <sub>DDR</sub>	-0.3 ~ +5.5	V
Input Voltage	V <sub>in</sub>	-0.3 ~ V <sub>DD</sub> +0.3	V
Operating Temperature	T <sub>opr</sub>	-40 ~ +85	°C
Storage Temperature	T <sub>stg</sub>	-40 ~ +125	°C
Power Dissipation	P <sub>D</sub>	300 (SSOP20)	mW

Note 1) All voltage are relative to “V<sub>SS</sub>= V<sub>SSL</sub>= V<sub>SSR</sub>=0V” reference.

Note 2) The LSI must be used inside of the “Absolute maximum ratings”. Otherwise, a stress may cause permanent damage to the LSI.

Note 3) De-coupling capacitors for V<sub>DD</sub>-V<sub>SS</sub>, V<sub>DDL</sub>-V<sub>SSL</sub>, and V<sub>DDR</sub>-V<sub>SSR</sub> should be connected for stable operation.

Note 4) Power Dissipation

The class-D amplifiers are more power efficiency, and dissipate power less than general analog-amplifiers. In theory, the **NJU8755** actualize quite high output-power such as 1.2W/channel at 5V operation with 8ohms load, and total power is supposed to be 2.4W. For this reason, it looks as if the **NJU8755** exceeds the absolute maximum rating of the power dissipation. However, in practice, the effective output-power of usual music sound is only about 1/10 of its maximum output power, thus it may never exceed the absolute maximum rating.

The maximum power dissipation in the system is calculated, as shown below.

$$P_{dmax}(W) = (T_{jmax}(°C) - T_a(°C)) / \theta_{ja}$$

P<sub>dmax</sub>: Maximum Power Dissipation, T<sub>jmax</sub>: Junction Temperature = 125°C

T<sub>a</sub>: Ambient Temperature, θ<sub>ja</sub>: Thermal Resistance of package(SSOP20) = 333°C/W

Power dissipation of the **NJU8755** itself is calculated, as shown below.

$$P_d(W) = P_o(W) \times R_o(\Omega) / R_L(\Omega) + P_{d_{IC}}(W)$$

P<sub>d</sub>: Power Dissipation, P<sub>o</sub>: Output Power, R<sub>o</sub>: Internal Resistance(output driver)

R<sub>L</sub>: Load Resistance, P<sub>d<sub>IC</sub></sub>: Power of internal circuit

## ■ ELECTRICAL CHARACTERISTICS

(Ta=25°C, V<sub>DD</sub>= V<sub>DDL</sub>= V<sub>DDR</sub>=5.0V, V<sub>SS</sub>=V<sub>SSL</sub>=V<sub>SSR</sub>=0V, Input Signal=1kHz,  
Input Signal Level=200mVrms, Frequency Band=20Hz~20kHz,  
Load Impedance=8Ω, 2nd-order 34kHz LC Filter(Q=0.85))

PARAMETER	SYMBOL	CONDITIONS	MIN	TYP	MAX	UNIT	Note
V <sub>DD</sub> , V <sub>DDP</sub> , V <sub>DDN</sub> Supply Voltage	V <sub>DD</sub>		2.7	5.0	5.25	V	
Input Impedance	Z <sub>IN</sub>	IN <sub>L</sub> , IN <sub>R</sub> pins	-	20	-	kΩ	
Voltage Gain	A <sub>V</sub>		-	23	-	dB	
Output Power Efficiency	E <sub>eff</sub>	Output THD=10%	80	-	-	%	
Output THD	THD	P <sub>o</sub> =0.6W	-	0.05	0.08	%	5
Output Power	P <sub>o</sub>	Output THD=10%	-	1.2	-	W/ch	
S/N	SN	A weight	-	80	-	dB	5
Dynamic Range	Drange	A weight	-	83	-	dB	5
Channel Separation	E <sub>chn</sub>	EIAJ(1kHz)	60	-	-	dB	
Output Level Difference Between L- and R- channels	CHD		-	-	3	dB	
Maximum Mute Attenuation	MAT		90	-	-	dB	
Operating Current (Standby)	I <sub>ST</sub>		-	-	1	μA	
Operating Current (No signal input)	I <sub>DD</sub>	No Filter No Load	-	7.5	10	mA	
Input Voltage	V <sub>IH</sub>	MUTE, STBY pins	0.7V <sub>DD</sub>	-	V <sub>DD</sub>	V	
	V <sub>IL</sub>	MUTE, STBY pins	0	-	0.3V <sub>DD</sub>	V	
Input Leakage Current	I <sub>LK</sub>	MUTE, STBY pins	-	-	±1.0	μA	

Note 5) Test system of the output THD, S/N and Dynamic Range

The output THD, S/N and dynamic range are tested in the system shown in Figure1, where a 2nd-order LC LPF and another filter incorporated in an audio analyzer are used.

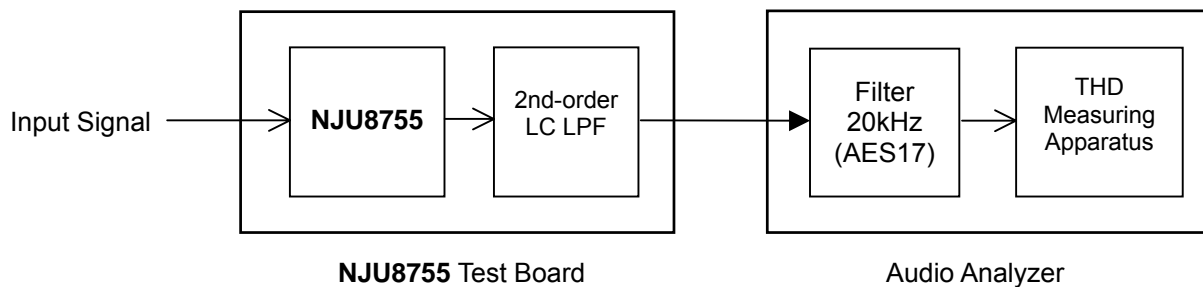

Figure 1. Output THD, S/N and Dynamic Range Test System

2nd-order LPF : fc=34kHz / Refer to "Typical Application Circuit".  
Filters : 22Hz HPF + 20kHz LPF(AES17)  
(with the A-Weight filter for S/N and Dynamic-range tests)

# NJU8755

## ■ TYPICAL APPLICATION CIRCUIT

<LCR Filter Configuration>

•A918CY-220M is manufactured by TOKO, INC.  
For detail information, please refer its technical papers.

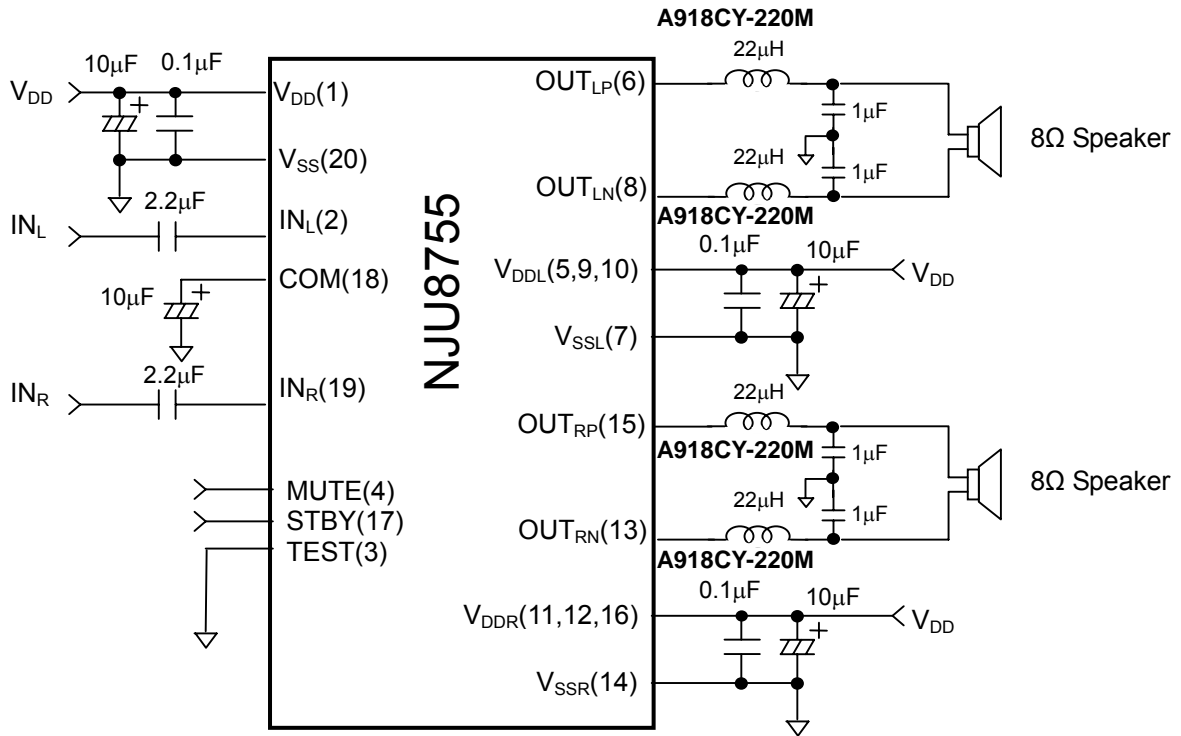

Figure 2.1. Application Circuit example

<LR Filter Configuration>

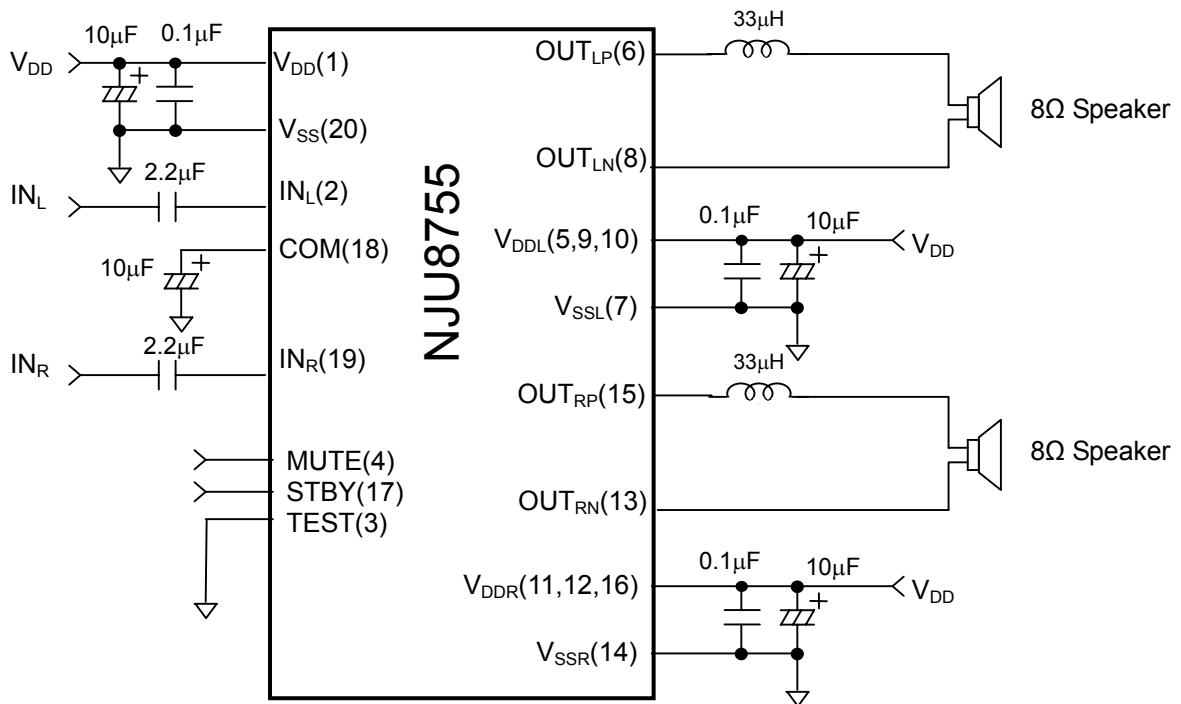

Figure 2.2. Application Circuit example

Using the LCR filter the power consumption is somewhat lower than using the LR filter power consumption when no signal input. The THD+N is somewhat influenced by the LR filter more than the LCR filter. Please test the circuit carefully to fit your application.

- Note 6) De-coupling capacitors must be connected between each power supply pin and GND.  
The capacity value should be adjusted on the application circuit and the operation temperature. It may malfunction if capacity value is small.
- Note 7) The power supply for  $V_{DDL}$  and  $V_{DDR}$  require fast driving response performance such as a switching regulator for better THD.  
THD performance becomes worse by ripple if the capacity of De-coupling capacitor is small.
- Note 8) The above circuit shows only application example and does not guarantee the any electrical characteristics. Therefore, please test the circuit carefully to fit your application.  
The cutoff frequency of the LC filter influences the quality of sound.  
The Q factor of the LC filter must be less than "1". Otherwise, the operating current increase when the frequency of input signal is closed to the cutoff frequency.
- Note 9) The transition time for MUTE and STBY signals must be less than 100 $\mu$ s. Otherwise, a malfunction may be occurred.
- Note 10) (1) – (20) indicates pin number.

[CAUTION]

The specifications on this databook are only given for information, without any guarantee as regards either mistakes or omissions. The application circuits in this databook are described only to show representative usages of the product and not intended for the guarantee or permission of any right including the industrial rights.



Компания «ЭлектроПласт» предлагает заключение долгосрочных отношений при поставках импортных электронных компонентов на взаимовыгодных условиях!

Наши преимущества:

- Оперативные поставки широкого спектра электронных компонентов отечественного и импортного производства напрямую от производителей и с крупнейших мировых складов;
- Поставка более 17-ти миллионов наименований электронных компонентов;
- Поставка сложных, дефицитных, либо снятых с производства позиций;
- Оперативные сроки поставки под заказ (от 5 рабочих дней);
- Экспресс доставка в любую точку России;
- Техническая поддержка проекта, помощь в подборе аналогов, поставка прототипов;
- Система менеджмента качества сертифицирована по Международному стандарту ISO 9001;
- Лицензия ФСБ на осуществление работ с использованием сведений, составляющих государственную тайну;
- Поставка специализированных компонентов (Xilinx, Altera, Analog Devices, Intersil, Interpoint, Microsemi, Aeroflex, Peregrine, Syfer, Eurofarad, Texas Instrument, Miteq, Cobham, E2V, MA-COM, Hittite, Mini-Circuits, General Dynamics и др.);

Помимо этого, одним из направлений компании «ЭлектроПласт» является направление «Источники питания». Мы предлагаем Вам помощь Конструкторского отдела:

- Подбор оптимального решения, техническое обоснование при выборе компонента;
- Подбор аналогов;
- Консультации по применению компонента;
- Поставка образцов и прототипов;
- Техническая поддержка проекта;
- Защита от снятия компонента с производства.



#### Как с нами связаться

**Телефон:** 8 (812) 309 58 32 (многоканальный)

**Факс:** 8 (812) 320-02-42

**Электронная почта:** [org@eplast1.ru](mailto:org@eplast1.ru)

**Адрес:** 198099, г. Санкт-Петербург, ул. Калинина, дом 2, корпус 4, литера А.