

## FEATURES

- 4 channels of low noise amplifiers (LNAs) followed by programmable gain amplifiers (PGAs)
- Minimum  $-3$  dB bandwidth of 5 MHz
- Typical  $-3$  dB bandwidth of 42.3 MHz
- Typical slew rate of 28 V/ $\mu$ s
- Differential input and output
- Gain of 18 dB to 36 dB in 6 dB steps
- Selectable low noise and low power modes
  - Input referred noise of 4.5 nV/ $\sqrt{\text{Hz}}$  at 18.3 mW per channel
  - Input referred noise of 3.8 nV/ $\sqrt{\text{Hz}}$  at 26.5 mW per channel
  - Input referred noise of 3.6 nV/ $\sqrt{\text{Hz}}$  at 34.8 mW per channel
  - Input referred noise of 3.4 nV/ $\sqrt{\text{Hz}}$  at 54.8 mW per channel
- Channel to channel gain matching of  $\pm 0.25$  dB
- Absolute gain error of  $\pm 0.5$  dB
- SPI programmable
- Power-down mode (SPI selectable)
- 3.1 V p-p differential output swing when using a 3.3 V supply
- 32-lead, 5 mm  $\times$  5 mm LFCSP package
- Specified from  $-40^{\circ}\text{C}$  to  $+125^{\circ}\text{C}$
- Qualified for automotive applications

## APPLICATIONS

- Automotive radar
  - Adaptive cruise control
  - Collision avoidance
  - Blind spot detection
  - Self parking
  - Electronic bumpers

## GENERAL DESCRIPTION

The ADA8282 is designed for applications that require low cost, low power, compact size, and flexibility. The ADA8282 has four parallel channels, each including an LNA and a PGA. The LNA and PGA combine to form a signal chain that features a gain range of 18 dB to 36 dB in 6 dB increments with a guaranteed minimum bandwidth of 5 MHz.

Using the highest power settings, the combined input referred voltage noise of the combined LNA and PGA channel is 3.4 nV/ $\sqrt{\text{Hz}}$  at maximum gain.

## FUNCTIONAL BLOCK DIAGRAM

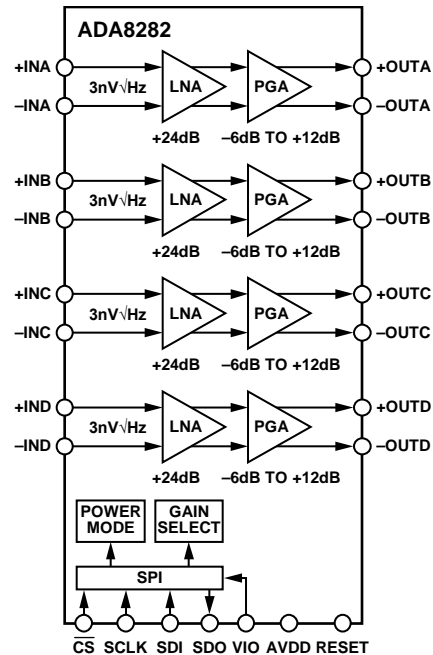

Figure 1.

13132-001

The ADA8282 can be configured in four power modes that trade off power and noise performance to optimize the overall performance according to the end application.

Fabricated in an advanced complementary metal-oxide semiconductor (CMOS) process, the ADA8282 is available in a 5 mm  $\times$  5 mm, RoHS-compliant, 32-lead LFCSP. It is specified over the automotive temperature range of  $-40^{\circ}\text{C}$  to  $+125^{\circ}\text{C}$ .

**TABLE OF CONTENTS**

Features.....	1	Output Swing Variation with Gain.....	12
Applications.....	1	Offset Voltage Adjustments.....	12
Functional Block Diagram.....	1	Single-Ended or Differential Input.....	12
General Description.....	1	Short-Circuit Currents.....	12
Revision History.....	2	SPI Interface.....	12
Specifications.....	3	Channel to Channel Phase Matching.....	13
Digital Specifications.....	4	Applications.....	14
Absolute Maximum Ratings.....	5	Increased Gain Using Two ADA8282 Devices in Series.....	14
Thermal Resistance.....	5	Multiplexing Inputs Using Multiple ADA8282 Devices.....	15
ESD Caution.....	5	Basic Connections for a Typical Application.....	16
Pin Configuration and Function Descriptions.....	6	Register Map.....	17
Typical Performance Characteristics.....	7	Register Summary.....	17
Theory of Operation.....	11	Register Details.....	17
Radar Receive Path AFE.....	11	Outline Dimensions.....	21
Default SPI Settings.....	11	Ordering Guide.....	21
Input Impedance.....	11	Automotive Products.....	21
Power Modes.....	11		
Programmable Gain Range.....	12		

**REVISION HISTORY**

7/15—Revision 0: Initial Version

## SPECIFICATIONS

AVDD = 3.3 V, LNA + PGA gain = 36 dB (LNA gain = 24 dB, PGA gain = 12 dB), T<sub>A</sub> = -40°C to +125°C, PGA\_BIAS\_SEL = b'10, LNA\_BIAS\_SEL = b'10, unless otherwise noted.

Table 1.

Parameter	Test Conditions/Comments	Min	Typ	Max	Unit
<b>ANALOG CHANNEL CHARACTERISTICS</b>					
Gain			18/24/30/36		dB
Gain Range			18		dB
Gain Error				±0.5	dB
-3 dB Bandwidth	V <sub>OUT</sub> = 100 mV p-p, gain = 36 dB				
	PGA_BIAS_SEL = b'00, LNA_BIAS_SEL = b'00	5	20.5		MHz
	PGA_BIAS_SEL = b'01, LNA_BIAS_SEL = b'01	5	34.2		MHz
	PGA_BIAS_SEL = b'01, LNA_BIAS_SEL = b'10	5	42.3		MHz
	PGA_BIAS_SEL = b'11, LNA_BIAS_SEL = b'11	5	52.3		MHz
Channel to Channel Gain Matching	Frequencies up to 5 MHz		0.1	±0.25	dB
Channel to Channel Phase Matching <sup>1</sup>	Frequencies up to 5 MHz		0.1	±1	Degrees
Slew Rate			28		V/μs
Input Referred Noise	Gain = 36 dB at 2 MHz				
	PGA_BIAS_SEL = b'00, LNA_BIAS_SEL = b'00		4.5		nV/√Hz
	PGA_BIAS_SEL = b'01, LNA_BIAS_SEL = b'01		3.8		nV/√Hz
	PGA_BIAS_SEL = b'01, LNA_BIAS_SEL = b'10		3.6		nV/√Hz
	PGA_BIAS_SEL = b'11, LNA_BIAS_SEL = b'11		3.4		nV/√Hz
	50 Ω impedance used for voltage to power conversion		-156		dBm/Hz
Output Referred Noise	Gain = 18 dB		36		nV/√Hz
	Gain = 24 dB		61		nV/√Hz
	Gain = 30 dB		115		nV/√Hz
	Gain = 36 dB		218		nV/√Hz
Offset Voltage					
Referred to Input	Gain = 36 dB		±0.8	±3	mV
Referred to Output	Gain = 36 dB		±50	±200	mV
SPI Offset Adjustment Resolution (Relative to Input)	LNA_BIAS_SEL = b'00		113		μV
	LNA_BIAS_SEL = b'01		186		μV
	LNA_BIAS_SEL = b'10		250		μV
	LNA_BIAS_SEL = b'11		440		μV
SPI Offset Adjustment Range (Relative to Input)	LNA_BIAS_SEL = b'00		±4		mV
	LNA_BIAS_SEL = b'01		±6		mV
	LNA_BIAS_SEL = b'10		±8		mV
	LNA_BIAS_SEL = b'11		±14		mV
Harmonic Distortion					
Second Harmonic (HD2)	V <sub>OUT</sub> = 2 V p-p, f <sub>IN</sub> = 100 kHz		-70		dBc
	V <sub>OUT</sub> = 100 mV p-p, f <sub>IN</sub> = 2 MHz		-85		dBc
Third Harmonic (HD3)	V <sub>OUT</sub> = 2 V p-p, f <sub>IN</sub> = 100 kHz		-85		dBc
	V <sub>OUT</sub> = 100 mV p-p, f <sub>IN</sub> = 2 MHz		-95		dBc
Intermodulation Distortion	V <sub>OUT</sub> = 2 V p-p, f <sub>IN1</sub> = 100 kHz, f <sub>IN2</sub> = 150 kHz		-72		dBc
	V <sub>OUT</sub> = 100 mV p-p, f <sub>IN1</sub> = 2 MHz, f <sub>IN2</sub> = 2.1 MHz		-83		dBc
Common-Mode Rejection Ratio (CMRR)			-80		dB
Crosstalk			-105		dBc

Parameter	Test Conditions/Comments	Min	Typ	Max	Unit
<b>POWER SUPPLY</b>					
Total Power Dissipation	PGA_BIAS_SEL = b'00, LNA_BIAS_SEL = b'00 PGA_BIAS_SEL = b'01, LNA_BIAS_SEL = b'01 PGA_BIAS_SEL = b'01, LNA_BIAS_SEL = b'10 PGA_BIAS_SEL = b'11, LNA_BIAS_SEL = b'11			73 106 139 219	mW mW mW mW
Power Dissipation per Channel			31		mW
AVDD		3.0		3.6	V
VIO		1.8		3.6	V
I <sub>AVDD</sub>	Four channels active PGA_BIAS_SEL = b'00, LNA_BIAS_SEL = b'00 PGA_BIAS_SEL = b'01, LNA_BIAS_SEL = b'01 PGA_BIAS_SEL = b'01, LNA_BIAS_SEL = b'10 PGA_BIAS_SEL = b'11, LNA_BIAS_SEL = b'11		19.6 29 37.7 60	22 32 42 66.3	mA mA mA mA
I <sub>VIO</sub>	One channel active		9.8	11	mA
Power-Down Current	I <sub>AVDD</sub> and I <sub>VIO</sub>		10	12	μA
Power-Down Dissipation			20	100	μA
Power-Up Time	Time to operational after chip is enabled		0.07	0.33	mW
Power Supply Rejection Ratio (PSRR)	At dc At 1 MHz	-80			μs dB dB
			-80		
<b>INPUT</b>					
Input Resistance					
Differential Input Resistance		1.45	1.57	1.7	kΩ
Common-Mode Input Resistance		0.37	0.39	0.42	kΩ
Differential Input Capacitance		10.8	12	13.2	pF
<b>OUTPUT</b>					
Output Voltage Swing	+OUTx (-OUTx), gain = 18 dB +OUTx (-OUTx), gain = 24 dB, 30 dB, or 36 dB	3.1 6.3			V p-p V p-p
Output Balance	f <sub>IN</sub> = 100 kHz		-70		dB
Short-Circuit Current	Per output at 25°C		205		mA
Capacitive Load	20% overshoot		30		pF

<sup>1</sup> Normalized to 0° phase matching at 25°C; see the Theory of Operation section for details.

**DIGITAL SPECIFICATIONS**

AVDD = 3.3 V, T<sub>A</sub> = -40°C to +125°C, unless otherwise noted.

**Table 2.**

Parameter	Temperature	Min	Typ	Max	Unit
<b>LOGIC INPUT (<math>\overline{CS}</math>)</b>					
Logic 1 Voltage	Full	1.2		V <sub>IO</sub> + 0.3	V
Logic 0 Voltage	Full			0.3	V
Input Resistance	25°C		15		kΩ
Input Capacitance	25°C		0.5		pF
<b>LOGIC INPUTS (SDI, SCLK, RESET)</b>					
Logic 1 Voltage	Full	1.2		V <sub>IO</sub> + 0.3	V
Logic 0 Voltage	Full	0		0.3	V
Input Resistance	25°C		2.5		kΩ
Input Capacitance	25°C		2		pF
Maximum SCLK Frequency				10	MHz
<b>LOGIC OUTPUT (SDO)</b>					
Logic 1 Voltage (I <sub>OH</sub> = 800 μA)	Full	V <sub>IO</sub> - 0.3			V
Logic 0 Voltage (I <sub>OL</sub> = 50 μA)	Full			0.3	V

## ABSOLUTE MAXIMUM RATINGS

Table 3.

Parameter	Rating
Electrical	
AVDD to EPAD	−0.3 V to +3.9 V
+IN <sub>x</sub> , −IN <sub>x</sub> , SCLK, SDI, SDO, $\overline{\text{CS}}$ , VIO, RESET, −OUT <sub>x</sub> , +OUT <sub>x</sub> to EPAD	−0.3V to AVDD + 0.3 V
ESD Ratings	
Human Body Model (HBM)	±4000 V
Charged Device Model (CDM)	±2000 V
Environmental	
Operating Temperature Range (Ambient)	−40°C to +125°C
Storage Temperature Range (Ambient)	−65°C to +150°C
Maximum Junction Temperature	150°C
Lead Temperature (Soldering, 10 sec)	300°C

Stresses at or above those listed under Absolute Maximum Ratings may cause permanent damage to the product. This is a stress rating only; functional operation of the product at these or any other conditions above those indicated in the operational section of this specification is not implied. Operation beyond the maximum operating conditions for extended periods may affect product reliability.

## THERMAL RESISTANCE

$\theta_{JA}$  is specified for the worst case conditions, that is, a device soldered in a circuit board for surface-mount packages.

Table 4. Thermal Resistance

Package Type	$\theta_{JA}$	$\theta_{JC}$	Unit
32-Lead, 5 mm × 5 mm LFCSP	33.51	4.1	°C/W

## ESD CAUTION



**ESD (electrostatic discharge) sensitive device.** Charged devices and circuit boards can discharge without detection. Although this product features patented or proprietary protection circuitry, damage may occur on devices subjected to high energy ESD. Therefore, proper ESD precautions should be taken to avoid performance degradation or loss of functionality.

## PIN CONFIGURATION AND FUNCTION DESCRIPTIONS

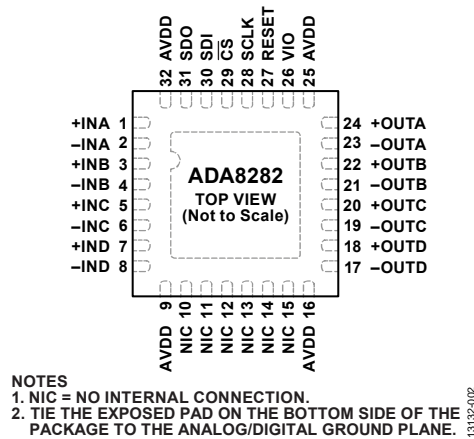

Figure 2. Pin Configuration

Table 5. Pin Function Descriptions

Pin No.	Mnemonic	Description
0	EPAD	Exposed Pad. Tie the exposed pad on the bottom side of the package to the analog/digital ground plane.
1	+INA	Positive LNA Analog Input for Channel A.
2	-INA	Negative LNA Analog Input for Channel A.
3	+INB	Positive LNA Analog Input for Channel B.
4	-INB	Negative LNA Analog Input for Channel B.
5	+INC	Positive LNA Analog Input for Channel C.
6	-INC	Negative LNA Analog Input for Channel C.
7	+IND	Positive LNA Analog Input for Channel D.
8	-IND	Negative LNA Analog Input for Channel D.
9	AVDD	3.3 V Analog Supply.
10	NIC	No Internal Connection. Leave this pin floating.
11	NIC	No Internal Connection. Leave this pin floating.
12	NIC	No Internal Connection. Leave this pin floating.
13	NIC	No Internal Connection. Leave this pin floating.
14	NIC	No Internal Connection. Leave this pin floating.
15	NIC	No Internal Connection. Leave this pin floating.
16	AVDD	3.3 V Analog Supply.
17	-OUTD	Negative Analog Output for Channel D.
18	+OUTD	Positive Analog Output for Channel D.
19	-OUTC	Negative Analog Output for Channel C.
20	+OUTC	Positive Analog Output for Channel C.
21	-OUTB	Negative Analog Output for Channel B.
22	+OUTB	Positive Analog Output for Channel B.
23	-OUTA	Negative Analog Output for Channel A.
24	+OUTA	Positive Analog Output for Channel A.
25	AVDD	3.3 V Analog Supply.
26	VIO	Digital Level Select for SPI and RESET. This pin can accept 1.8 V to 3.3 V.
27	RESET	Reset Input. RESET overrides the SPI and powers down the device and returns all settings back to default. RESET is pulled to ground by default. A logic high triggers the reset.
28	SCLK	Serial Clock.
29	$\overline{\text{CS}}$	Chip Select Bar.
30	SDI	Serial Data Input.
31	SDO	Serial Data Output.
32	AVDD	3.3 V Analog Supply.

# TYPICAL PERFORMANCE CHARACTERISTICS

AVDD = 3.3 V, LNA + PGA gain = 36 dB (LNA gain = 24 dB, PGA gain = 12 dB),  $T_A = 25^\circ\text{C}$ , PGA\_BIAS\_SEL = b'10, LNA\_BIAS\_SEL = b'10, unless otherwise noted.

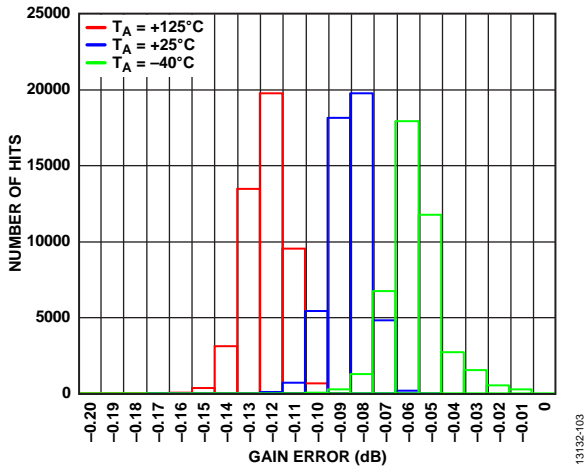

Figure 3. Gain Accuracy Distribution

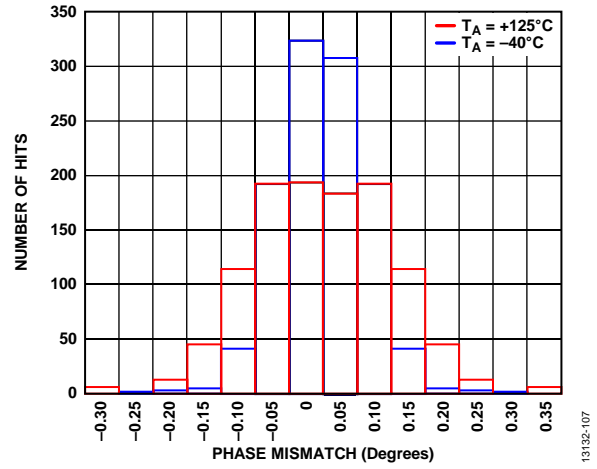

Figure 6. Distribution of Channel to Channel Phase Matching

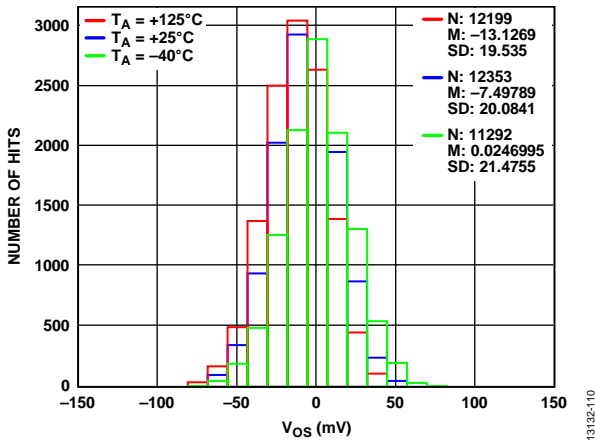

Figure 4. Output Offset Voltage Distribution

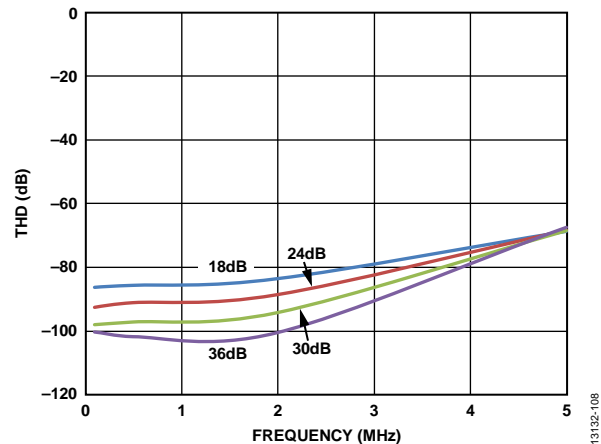

Figure 7. Total Harmonic Distortion (THD) vs. Frequency for Various Gains,  $V_{OUT} = -10\text{ dBm}$

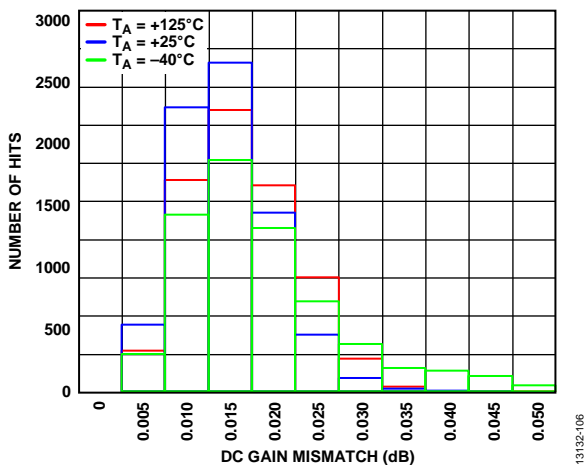

Figure 5. Distribution of Channel to Channel Gain Matching

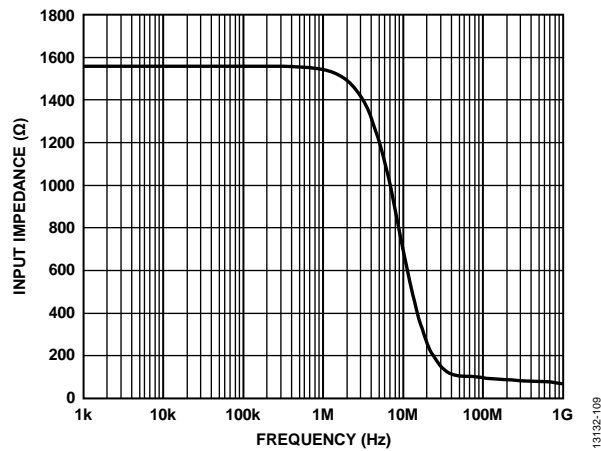

Figure 8. Input Impedance vs. Frequency

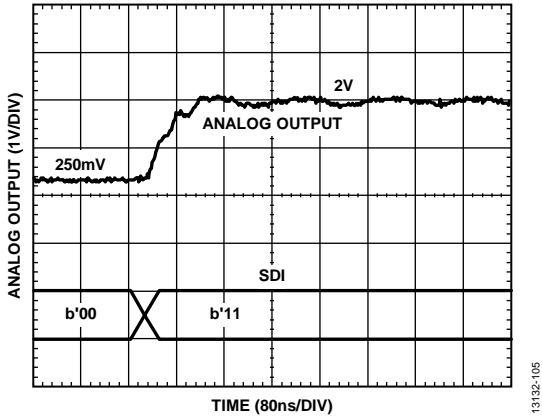

Figure 9. Gain Step Transient Response

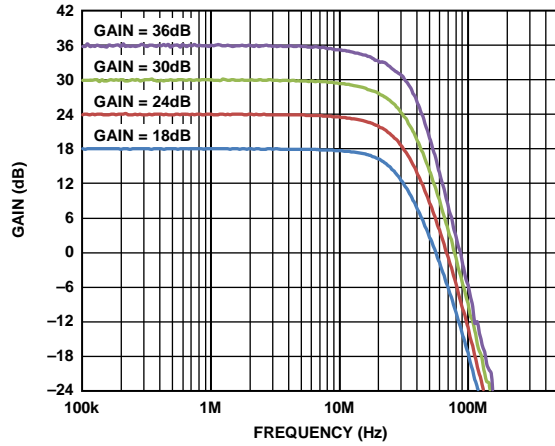

Figure 12. Frequency Response at All Gains (Bias Mode 0)

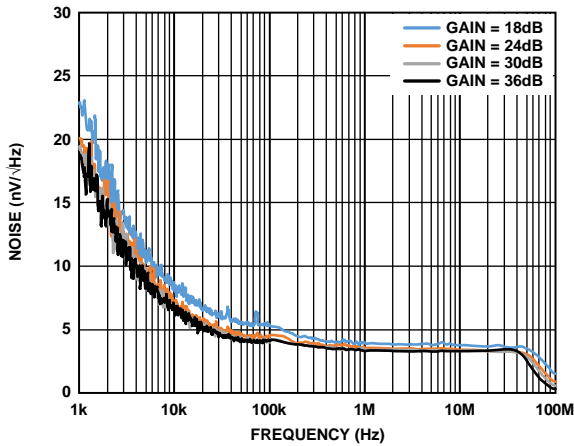

Figure 10. Input Referred Noise vs. Frequency

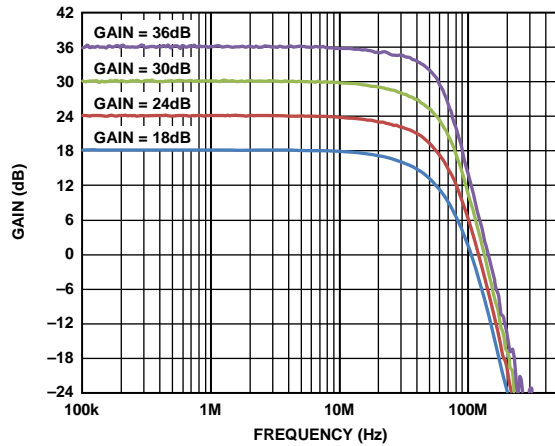

Figure 13. Frequency Response at All Gains (Bias Mode 2)

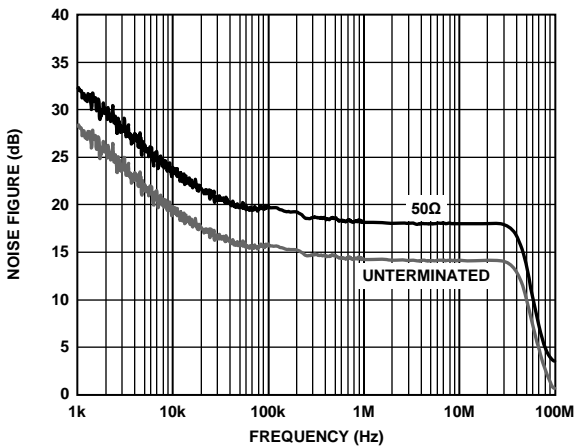

Figure 11. Noise Figure vs. Frequency

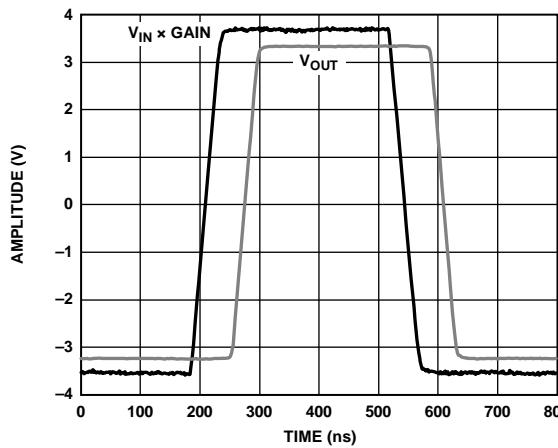

Figure 14. Overdrive Recovery



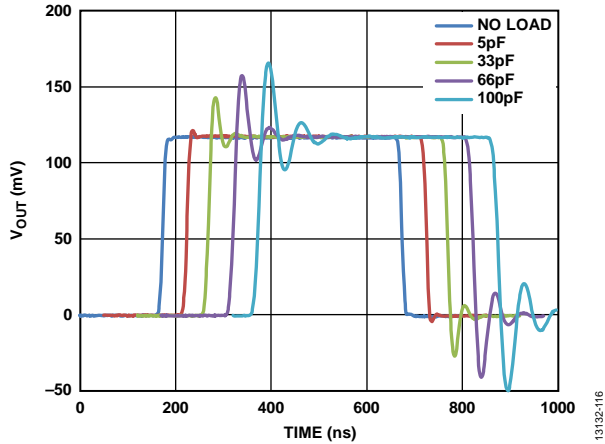

Figure 15. Pulse Response at Various Output Capacitive Loads

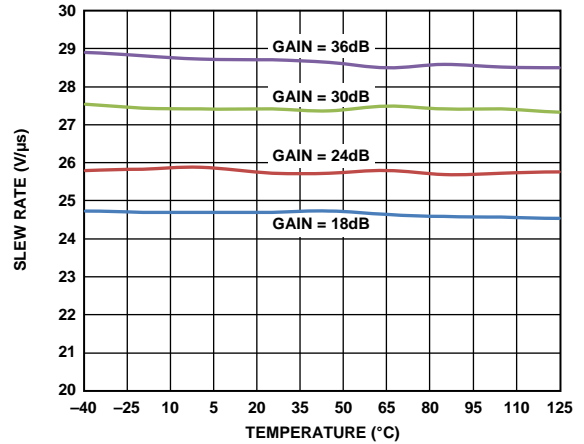

Figure 18. Output Slew Rate vs. Temperature

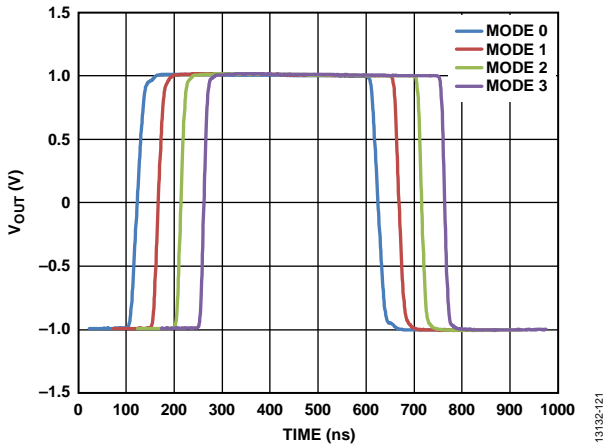

Figure 16. Large Signal Pulse Response for Various LNA and PGA Bias Modes

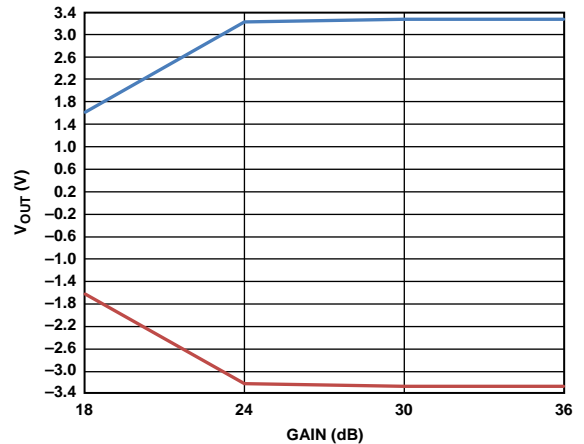

Figure 19. Maximum and Minimum Differential  $V_{OUT}$  vs. Gain

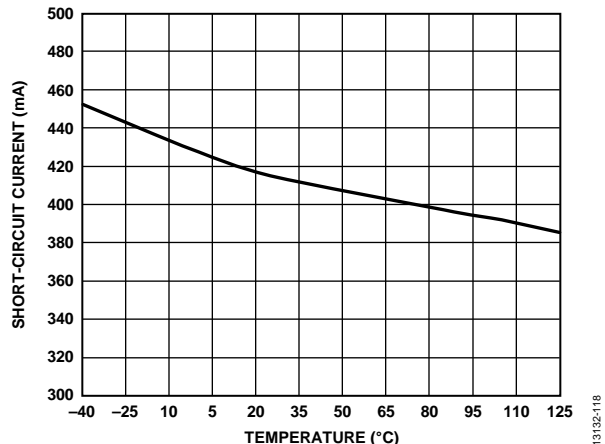

Figure 17. Short-Circuit Current vs. Temperature Per Channel

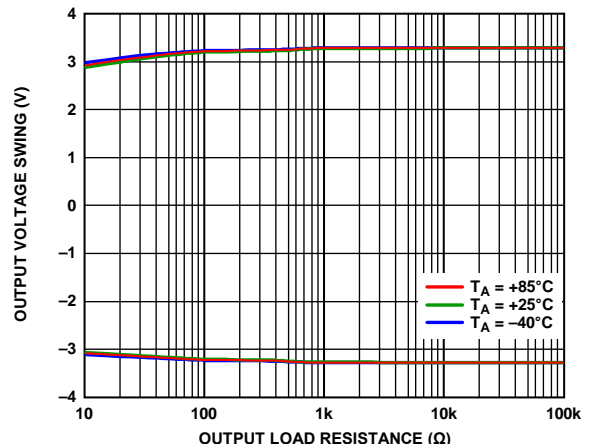

Figure 20. Differential Output Voltage Swing vs. Output Load Resistance

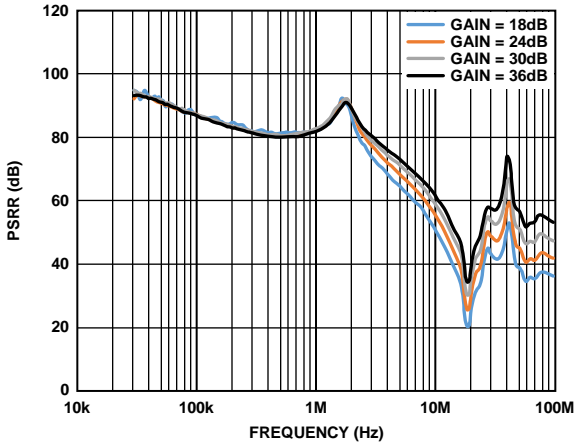

Figure 21. PSRR vs. Frequency at Various Gains

13132-122

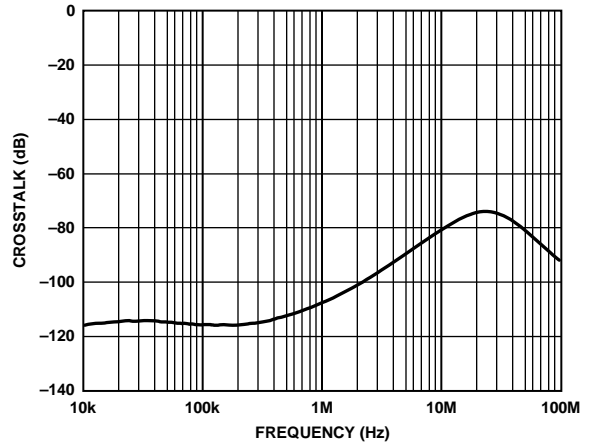

Figure 23. Crosstalk vs. Frequency

13132-124

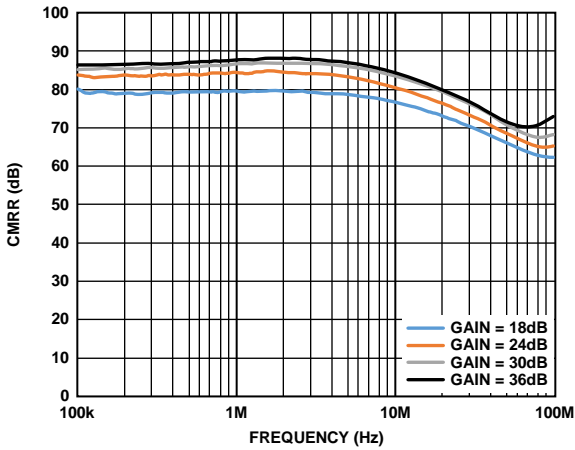

Figure 22. CMRR vs. Frequency at Various Gains

13132-123

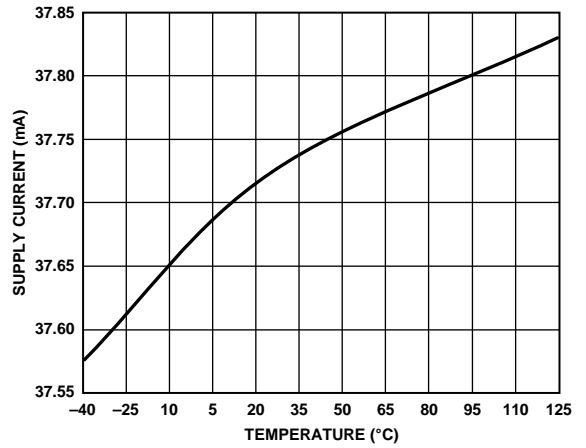

Figure 24. Quiescent Supply Current vs. Temperature

13132-120

## THEORY OF OPERATION

### RADAR RECEIVE PATH AFE

The primary application for the ADA8282 is a high speed ramp, frequency modulated, continuous wave radar (HSR-FMCW radar). Figure 25 shows a simplified block diagram of an HSR-FMCW radar system. The signal chain requires multiple channels, each including an LNA and a PGA. The ADA8282 provides these key components in a single 5 mm × 5 mm LFCSP.

The performance of each component is designed to meet the demands of an HSR-FMCW radar system. Some examples of these performance metrics are the LNA noise, PGA gain range, and signal chain bandwidth and power. The ADA8282 also has adjustable power modes to adjust the power and performance level to accommodate a wide variety of applications.

The ADA8282 is programmable via the SPI. Channel gain, power mode, and offset voltage can be adjusted using the SPI port.

### DEFAULT SPI SETTINGS

When initially powered, the ADA8282 defaults to a setting of 0x00 in Register 0x17, which disables all channels. The device is enabled by writing 0x0F to Register 0x17.

### INPUT IMPEDANCE

The input impedance to the ADA8282 is set by an internal 785 Ω resistance at each input, biased to midsupply by an internal voltage buffer. Both the positive and negative inputs are biased with the same network, creating a differential input impedance of 1.57 kΩ.

The input to the ADA8282 is typically ac-coupled. The ac coupling capacitors operate with the input impedance of the ADA8282 to create a high-pass filter with a pole at  $1/(2\pi RC)$ , where  $R = 785 \Omega$  with a typical tolerance of  $\pm 15\%$ .

### POWER MODES

The ADA8282 has four power modes that can be controlled through Register 0x14 (BIAS\_SEL). The power modes allow a user to adjust the power and performance tradeoffs to suit the end application. Use the low power mode when power savings are in demand, and use the high power mode in applications that require increased bandwidth and low noise.

Table 6 shows the power performance trade-offs of the various SPI settings.

Table 6. Power Mode Trade-Offs

Mode Setting	Power per Channel (mW)	Input Referred Noise at 2 MHz (nV/√Hz)	Typical Bandwidth (MHz), Gain = 36 dB
b'00	18.3	4.5	20.5
b'01	26.5	3.8	34.2
b'10	34.8	3.6	42.3
b'11	54.8	3.4	52.3

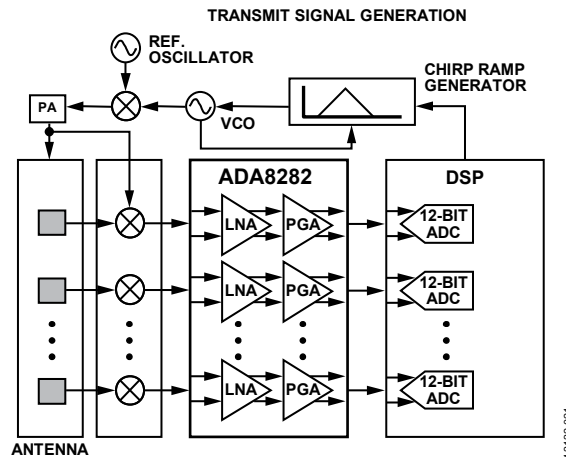

Figure 25. Typical Signal Chain Overview

**PROGRAMMABLE GAIN RANGE**

The ADA8282 has a programmable gain to allow adjusting of the output amplitudes of signals to accommodate a variety of applications. The gain of the ADA8282 is programmable in 6 dB increments from 18 dB to 36 dB. The gain is controlled using Register 0x15. The same register controls all four channels, but each channel can be independently controlled by utilizing the appropriate bits in the register. Channel A is controlled with the two LSBs of Register 0x15 (Bits[1:0]), Channel B uses Bits[3:2], Channel C uses Bits[5:4], and Channel D uses the two MSBs, Bits[7:6].

The gain setting and gains are listed in Table 7.

**Table 7. Gain Settings**

Register 0x15 Setting	Gain (dB)	Gain (V/V)
b'00	18	7.9
b'01	24	15.9
b'10	30	31.6
b'11	36	63.1

**OUTPUT SWING VARIATION WITH GAIN**

The ADA8282 gain is implemented using two internal gain stages. The first stage is an LNA with a gain of 24 dB, and the second stage is a PGA with a gain that varies from -6 dB to +12 dB. The output of the LNA has a fixed output swing range, and is the limiting factor when the channel gain is 18 dB. Because of the limitations of the LNA swing range, the ADA8282 has an output swing that is dependent on gain, as shown in Table 8.

**Table 8. Output Swing at Various Gains**

Gain (dB)	Output Swing (V p-p)
18	3.1
24	6.3
30	6.3
36	6.3

**OFFSET VOLTAGE ADJUSTMENTS**

Register 0x10 through Register 0x13 adjust the dc offset voltage of each channel. The default value of 0x20 is intended to be the setting for the offset closest to 0 V, but adjustments can be made as required by the application.

The default setting (0x20) applies a zero offset, 0x00 applies the maximum negative offset, and 0x3F applies the maximum positive offset.

The range and resolution of the LNA\_OFFSETx adjustments are dependent on the LNA bias mode as described in Table 9.

**Table 9. Offset Voltage Adjustments**

LNA_BIAS_SEL Setting	Referred to Input (RTI) Offset Resolution (µV)	RTI Offset Range (mV)
b'00	113	±4
b'01	186	±6
b'10	250	±8
b'11	440	±14

**VIO Pin**

The VIO pin sets the voltage levels used by the SPI interface. If the VIO pin is tied to the 3.3 V supply, the SPI port functions on 3.3 V logic.

**SINGLE-ENDED OR DIFFERENTIAL INPUT**

The ADA8282 operates with either a differential or single-ended signal source. The maximum input voltage swing is the same in either configuration. When using a single-ended signal source, connect the unused input to ground with a capacitor. Matching the ac coupling capacitor to the ac grounding capacitor optimizes CMRR performance.

**SHORT-CIRCUIT CURRENTS**

The ADA8282 typically has a 205 mA short-circuit current per output pin. The thermal implications of this current during unintended shorting of these outputs must be taken into account when designing boards with this device.

**SPI INTERFACE**

The ADA8282 SPI interface uses a 4-wire interface to deliver a 16-bit instruction header, followed by 8 bits of data. The first bit is a read/write bit. W1 and W0 determine how many bytes are transferred, and must both be zeros for the ADA8282 to write to a single register. Then, a 13-bit address and an 8-bit data byte follow.

The SPI port operates at SCLK frequencies of up to 10 MHz. For additional SPI timing information, see the AN-877 Application Note.

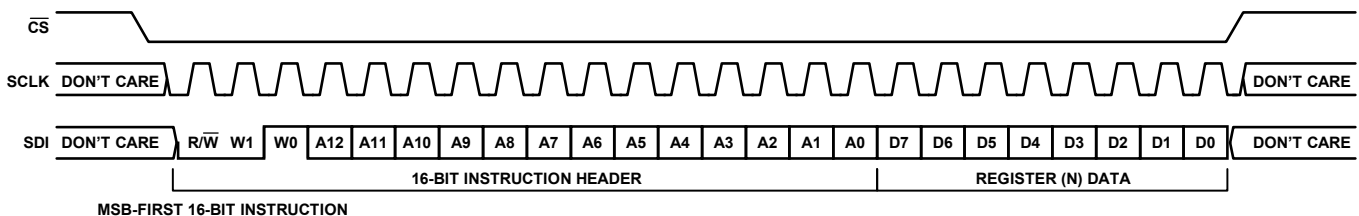

Figure 26. Serial Instruction Details

### CHANNEL TO CHANNEL PHASE MATCHING

In a multichannel radar application, matching the ac performance between channels improves the distance and angle resolution of a detected object, particularly the phase matching in the band of interest for the application. The ADA8282 layout and design are optimized to increase phase matching. The ADA8282 also has sufficient bandwidth to minimize any channel to channel phase variation for up to 5 MHz input signals.

The phase mismatch between channels can be calibrated at a single temperature. However, any variation in phase matching over temperature can still degrade system performance. The ADA8282 is characterized to capture the maximum channel to channel phase mismatch as the temperature varies from a calibration temperature of 25°C.

Figure 27 shows a distribution of channel to channel phase mismatch for signal frequencies up to 5 MHz. When the initial phase mismatch between channels is normalized to 0° at +25°C, the 6σ mismatch is 0.43° at -40°C and 0.6° at +125°C.

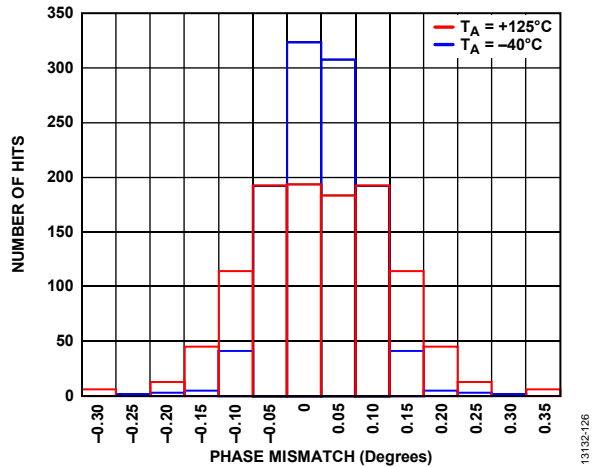

Figure 27. Channel to Channel Phase Mismatch, Normalized to 0° at 25°C, LNA\_BIAS\_SEL = PGA\_BIAS\_SEL = b'00, PGA\_GAIN = b'11

The amount of channel to channel phase mismatch varies with the power mode. Table 10 shows the 6σ phase mismatch up to 5 MHz over the full temperature range for all gain settings in different power modes, when normalized to 0° at 25°C in each power mode.

Table 10. Maximum Channel to Channel Phase Mismatch over Temperature After 25°C Calibration

PGA_BIAS_SEL	LNA_BIAS_SEL	6σ Channel to Channel Phase Mismatch over Temperature (Degrees)	Maximum Channel to Channel Phase Mismatch (Degrees)
b'00	b'00	0.60	±1
b'01	b'01	0.41	±1
b'10	b'10	0.33	±1
b'11	b'11	0.60	±1

## APPLICATIONS INFORMATION

### INCREASED GAIN USING TWO ADA8282 DEVICES IN SERIES

For applications that require gains greater than 36 dB, two ADA8282 devices can be used in series with each other. To optimize the signal swing for the path, increment the gains according to Table 11.

Table 11. Gain Settings for Two Devices in Series

Total Gain (dB)	A1 (Input Side ADA8282) Gain (dB)	A2 (Output Side ADA8282) Gain (dB)
36	18	18
42	18	24
48	24	24
54	30	24
60	30	30
66	36	30
72	36	36

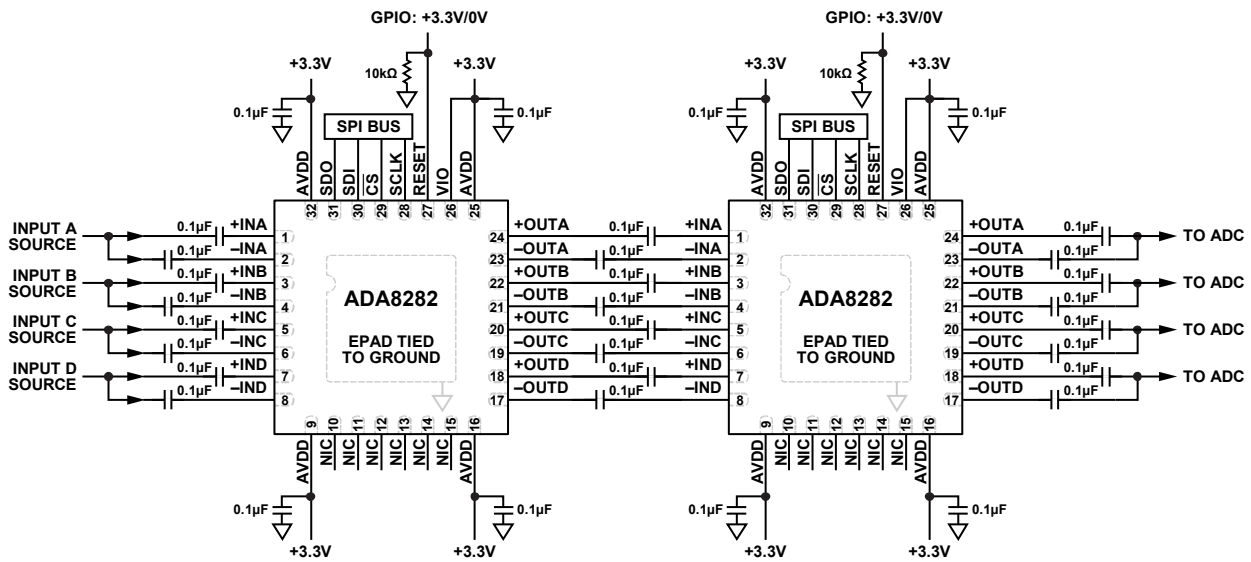

Figure 28. Using Two ADA8282 Devices in Series to Increase Gain

13132-023

**MULTIPLEXING INPUTS USING MULTIPLE ADA8282 DEVICES**

It is possible to multiplex eight differential inputs down to four differential outputs by using two ADA8282 devices. The devices can be connected such that the outputs are connected (see

Figure 29) as long as only one device is enabled at a time. When an ADA8282 is disabled, the outputs present a 6 kΩ load on the output bus.

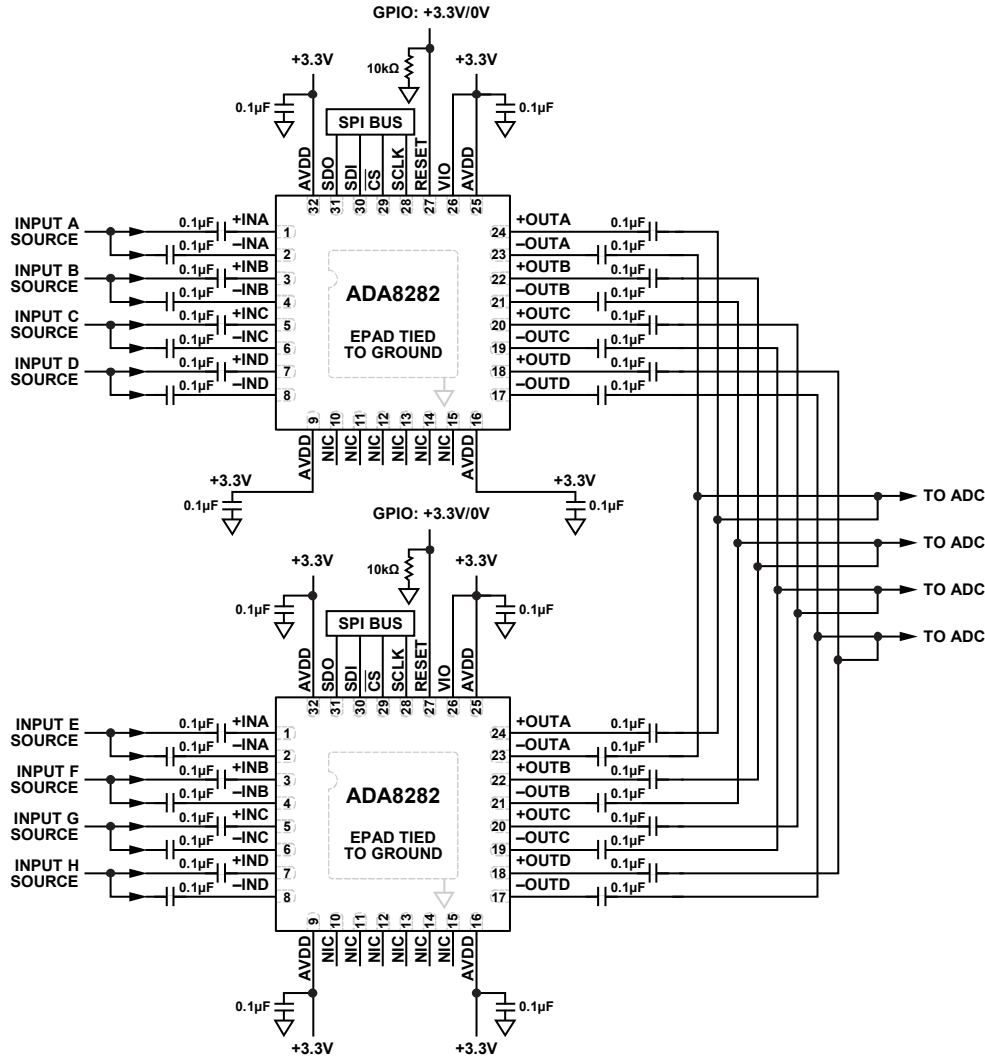

Figure 29. Multiplexing by Connecting Two ADA8282 Outputs to One Output Bus

13132-024

**BASIC CONNECTIONS FOR A TYPICAL APPLICATION**

The ADA8282 is typically configured to operate with a nominal 3.3 V power supply, using the EPAD as the analog ground connection. Place the bypass capacitors as close as possible to the power supply pins to minimize the length of metal traces in

series with the bypassing paths. AC couple the inputs and outputs for each channel as shown in Figure 30. Pull the RESET pin low with a 10 kΩ resistor and drive it with 3.3 V GPIO logic. The SPI pins can be directly connected to the SPI bus.

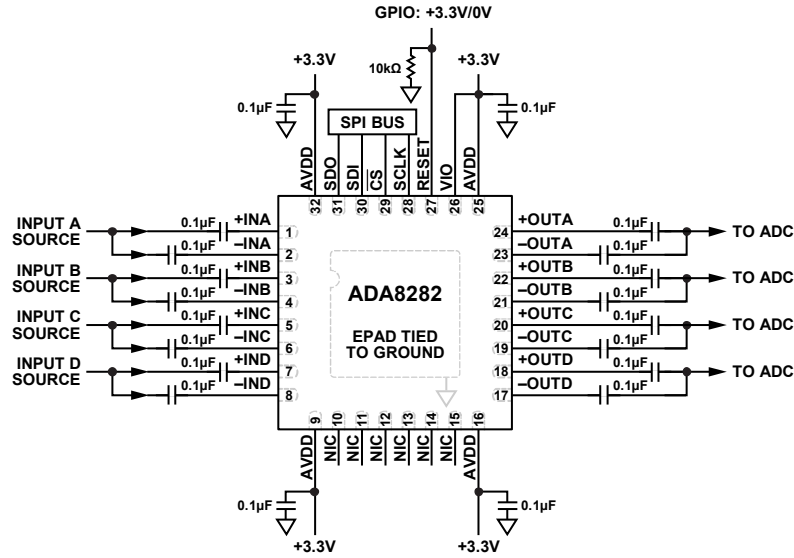

Figure 30. Typical Component Connections

13132-025



## REGISTER MAP

### REGISTER SUMMARY

Table 12. Register Summary

Reg.	Name	Bits	Bit 7	Bit 6	Bit 5	Bit 4	Bit 3	Bit 2	Bit 1	Bit 0	Reset	RW
0x00	INTF_CONFA	[7:0]	INTF_CONFA2	LSBFIRST1	INTF_CONFA1	LSBFIRST0	INTF_CONFA0				0x00	RW
0x01	SOFT_RESET	[7:0]	Unused							SOFT_RESET	0x00	R
0x04	CHIP_ID1	[7:0]	CHIP_IDLOW							0x82	R	
0x05	CHIP_ID2	[7:0]	CHIP_IDHI							0x82	R	
0x06	Revision	[7:0]	Revision							0x00	R	
0x10	LNA_OFFSET0	[7:0]	Unused	LNA_OFFSET0					0x20	RW		
0x11	LNA_OFFSET1	[7:0]	Unused	LNA_OFFSET1					0x20	RW		
0x12	LNA_OFFSET2	[7:0]	Unused	LNA_OFFSET2					0x20	RW		
0x13	LNA_OFFSET3	[7:0]	Unused	LNA_OFFSET3					0x20	RW		
0x14	BIAS_SEL	[7:0]	Unused			PGA_BIAS_SEL	LNA_BIAS_SEL	0x0A		RW		
0x15	PGA_GAIN	[7:0]	PGA_GAIN3	PGA_GAIN2	PGA_GAIN1	PGA_GAIN0	0x00		RW			
0x17	EN_CHAN	[7:0]	Unused			EN_CHANNEL3	EN_CHANNEL2	EN_CHANNEL1	EN_CHANNEL0	0x00	RW	
0x18	EN_BIAS_GEN	[7:0]	Unused							EN_BIAS_GEN	0x00	RW
0x1D	SPAREWRO	[7:0]	Unused					GPIO_WRITE	GPIO_WR_MODE	0x00	RW	
0x1E	SPARERD0	[7:0]	Unused							GPIO_READ	0x00	R

### REGISTER DETAILS

#### Register 0x00: Interface Configuration Register

Bit 7	Bit 6	Bit 5	Bit 4	Bit 3	Bit 2	Bit 1	Bit 0
INTF_CONFA2	LSBFIRST1	INTF_CONFA1	LSBFIRST0	INTF_CONFA0			

The INTF\_CONFA configuration register is symmetric, as it is the first register written and sets the data direction (LSB first or MSB first).

Table 13. INTF\_CONFA Configuration Register Bit Descriptions

Bits	Bit Name	Description	Reset	Access
[7:0]	INTF_CONFA2	INTF_CONFA2 must remain b'00.	0x00	RW
5	LSBFIRST1	LSBFIRST1 must be set to b'1 for LSB first operation and to b'0 for MSB first operation.	0x00	RW
[4:3]	INTF_CONFA1	INTF_CONFA1 must remain b'00.	0x00	RW
2	LSBFIRST0	LSBFIRST0 must be set to b'1 for LSB first operation and to b'0 for MSB first operation.	0x00	RW
[1:0]	INTF_CONFA0	INTF_CONFA0 must remain b'00.	0x00	RW

#### Register 0x01: Soft Reset Register

Bit 7	Bit 6	Bit 5	Bit 4	Bit 3	Bit 2	Bit 1	Bit 0
Unused							SOFT_RESET

Table 14. SOFT\_RESET Configuration Register Bit Descriptions

Bits	Bit Name	Description	Reset	Access
0	SOFT_RESET	The SOFT_RESET bit resets all registers to their default values when SOFT_RESET is set to b'1.	0x00	RW

#### Register 0x04: Chip ID Low Register

Bit 7	Bit 6	Bit 5	Bit 4	Bit 3	Bit 2	Bit 1	Bit 0
CHIP_IDLOW							

Table 15. CHIP\_IDLOW Configuration Register Bit Descriptions

Bits	Bit Name	Description	Reset	Access
[7:0]	CHIP_IDLOW	The CHIP_ID1 and CHIP_ID2 registers identify the <a href="#">ADA8282</a> .	0x82	R

**Register 0x05: Chip ID High Register**

Bit 7	Bit 6	Bit 5	Bit 4	Bit 3	Bit 2	Bit 1	Bit 0
CHIP_IDHI							

**Table 16. CHIP\_IDHI Configuration Register Bit Descriptions**

Bits	Bit Name	Description	Reset	Access
[7:0]	CHIP_IDHI	The CHIP_ID1 and CHIP_ID2 registers identify the <a href="#">ADA8282</a> .	0x82	R

**Register 0x06: Revision Register**

Bit 7	Bit 6	Bit 5	Bit 4	Bit 3	Bit 2	Bit 1	Bit 0
Revision							

**Table 17. Revision Configuration Register Bit Descriptions**

Bits	Bit Name	Description	Reset	Access
[7:0]	Revision	The revision register identifies the silicon revision of the current die.	0x00	R

**Register 0x10: LNA Offset 0 Register**

Bit 7	Bit 6	Bit 5	Bit 4	Bit 3	Bit 2	Bit 1	Bit 0
Unused		LNA_OFFSET0					

**Table 18. LNA\_OFFSET0 Configuration Register Bit Descriptions**

Bits	Bit Name	Description	Reset	Access
[5:0]	LNA_OFFSET0	LNA_OFFSET0 controls the offset of Channel A. The default setting (0x20) applies the minimum offset, 0x00 applies the maximum negative offset, and 0x3F applies the maximum positive offset. The resolution of the offset varies with the LNA bias mode as follows: LNA Bias Mode 0: 113 $\mu$ V RTI offset resolution, $\pm 4$ mV range. LNA Bias Mode 1: 186 $\mu$ V RTI offset resolution, $\pm 6$ mV range. LNA Bias Mode 2: 250 $\mu$ V RTI offset resolution, $\pm 8$ mV range. LNA Bias Mode 3: 440 $\mu$ V RTI offset resolution, $\pm 14$ mV range.	0x20	RW

**Register 0x11: LNA Offset 1 Register**

Bit 7	Bit 6	Bit 5	Bit 4	Bit 3	Bit 2	Bit 1	Bit 0
Unused		LNA_OFFSET1					

**Table 19. LNA\_OFFSET1 Configuration Register Bit Descriptions**

Bits	Bit Name	Description	Reset	Access
[5:0]	LNA_OFFSET1	LNA_OFFSET0 controls the offset of Channel B. The default setting (0x20) applies the minimum offset, 0x00 applies the maximum negative offset, and 0x3F applies the maximum positive offset. The resolution of the offset varies with the LNA bias mode as follows: LNA Bias Mode 0: 113 $\mu$ V RTI offset resolution, $\pm 4$ mV range. LNA Bias Mode 1: 186 $\mu$ V RTI offset resolution, $\pm 6$ mV range. LNA Bias Mode 2: 250 $\mu$ V RTI offset resolution, $\pm 8$ mV range. LNA Bias Mode 3: 440 $\mu$ V RTI offset resolution, $\pm 14$ mV range.	0x20	RW

**Register 0x12: LNA Offset 2 Register**

Bit 7	Bit 6	Bit 5	Bit 4	Bit 3	Bit 2	Bit 1	Bit 0
Unused		LNA_OFFSET2					

Table 20. LNA\_OFFSET2 Configuration Register Bit Descriptions

Bits	Bit Name	Description	Reset	Access
[5:0]	LNA_OFFSET2	LNA_OFFSET0 controls the offset of Channel C. The default setting (0x20) applies the minimum offset, 0x00 applies the maximum negative offset, and 0x3F applies the maximum positive offset. The resolution of the offset varies with the LNA bias mode as follows: LNA Bias Mode 0: 113 $\mu$ V RTI offset resolution, $\pm$ 4 mV range. LNA Bias Mode 1: 186 $\mu$ V RTI offset resolution, $\pm$ 6 mV range. LNA Bias Mode 2: 250 $\mu$ V RTI offset resolution, $\pm$ 8 mV range. LNA Bias Mode 3: 440 $\mu$ V RTI offset resolution, $\pm$ 14 mV range.	0x20	RW

**Register 0x13: LNA Offset 3 Register**

Bit 7	Bit 6	Bit 5	Bit 4	Bit 3	Bit 2	Bit 1	Bit 0
Unused		LNA_OFFSET3					

Table 21. LNA\_OFFSET3 Configuration Register Bit Descriptions

Bits	Bit Name	Description	Reset	Access
[5:0]	LNA_OFFSET3	LNA_OFFSET0 controls the offset of Channel D. The default setting (0x20) applies the minimum offset, 0x00 applies the maximum negative offset, and 0x3F applies the maximum positive offset. The resolution of the offset varies with the LNA bias mode as follows: LNA Bias Mode 0: 113 $\mu$ V RTI offset resolution, $\pm$ 4 mV range. LNA Bias Mode 1: 186 $\mu$ V RTI offset resolution, $\pm$ 6 mV range. LNA Bias Mode 2: 250 $\mu$ V RTI offset resolution, $\pm$ 8 mV range. LNA Bias Mode 3: 440 $\mu$ V RTI offset resolution, $\pm$ 14 mV range.	0x20	RW

**Register 0x14: PGA Bias Register**

Bit 7	Bit 6	Bit 5	Bit 4	Bit 3	Bit 2	Bit 1	Bit 0
Unused			PGA_BIAS_SEL		LNA_BIAS_SEL		

The PGA bias select register allows the user to trade off power and performance (for example, bandwidth and noise).

Table 22. BIAS\_SEL Configuration Register Bit Descriptions

Bits	Bit Name	Description	Reset	Access
[3:2]	PGA_BIAS_SEL	Set PGA_BIAS_SEL to b'00 for the minimum PGA bias and to b'11 for the maximum PGA bias.	0x00	RW
[1:0]	LNA_BIAS_SEL	Set LNA_BIAS_SEL to b'00 for the minimum LNA bias and to b'11 for the maximum LNA bias.	0x00	RW

**Register 0x15: PGA Gain Register**

Bit 7	Bit 6	Bit 5	Bit 4	Bit 3	Bit 2	Bit 1	Bit 0
PGA_GAIN3		PGA_GAIN2		PGA_GAIN1		PGA_GAIN0	

The PGA gain register allows independent gain settings for each channel.

Table 23. PGA\_GAIN Configuration Register Bit Descriptions

Bits	Bit Name	Description	Reset	Access
[7:6]	PGA_GAIN3	Set PGA_GAIN3 to b'00 for 18 dB gain, to b'01 for 24 dB gain, to b'10 for 30 dB gain, and to b'11 for 36 dB gain for Channel D	0x00	RW
[5:4]	PGA_GAIN2	Set PGA_GAIN2 to b'00 for 18 dB gain, to b'01 for 24 dB gain, to b'10 for 30 dB gain, and to b'11 for 36 dB gain for Channel C	0x00	RW
[3:2]	PGA_GAIN1	Set PGA_GAIN1 to b'00 for 18 dB gain, to b'01 for 24 dB gain, to b'10 for 30 dB gain, and to b'11 for 36 dB gain for Channel B	0x00	RW
[1:0]	PGA_GAIN0	Set PGA_GAIN0 to b'00 for 18 dB gain, to b'01 for 24 dB gain, to b'10 for 30 dB gain, and to b'11 for 36 dB gain for Channel A	0x00	RW

**Register 0x17: Enable Channel Register**

Bit 7	Bit 6	Bit 5	Bit 4	Bit 3	Bit 2	Bit 1	Bit 0
Unused				EN_CHANNEL3	EN_CHANNEL2	EN_CHANNEL1	EN_CHANNEL0

The enable channel register allows individual channels to be enabled or disabled. The default mode for the channel is disabled. Write 0x0F to the EN\_CHAN register to enable all channels.

When a channel is disabled but the bias generator is still enabled, the channel's current consumption is <100  $\mu$ A. When a channel is disabled, its output pins are high-Z. The enable channel register resets at AVDD power-on to 0x00 to avoid inrush current for fast supply ramps.

**Table 24. EN\_CHAN Register Bit Descriptions**

Bits	Bit Name	Description	Reset	Access
3	EN_CHANNEL3	Set to b'1 to enable Channel D, and set to b'0 to disable Channel D	0x00	RW
2	EN_CHANNEL2	Set to b'1 to enable Channel C, and set to b'0 to disable Channel C	0x00	RW
1	EN_CHANNEL1	Set to b'1 to enable Channel B, and set to b'0 to disable Channel B	0x00	RW
0	EN_CHANNEL0	Set to b'1 to enable Channel A, and set to b'0 to disable Channel A	0x00	RW

**Register 0x18: Enable Bias Generator Register**

Bit 7	Bit 6	Bit 5	Bit 4	Bit 3	Bit 2	Bit 1	Bit 0
Unused							EN_BIAS_GEN

When any channel is enabled, the bias generator is automatically enabled. The EN\_BIAS\_GEN register controls whether the bias generator stays active, even when all channels are disabled. Leaving the bias generator active decreases the enable time of the device.

**Table 25. EN\_BIAS\_GEN Register Bit Descriptions**

Bits	Bit Name	Description	Reset	Access
0	EN_BIAS_GEN	Setting EN_BIAS_GEN to 1 keeps the bias generator active, providing a faster enable time (~2 $\mu$ s).	0x00	RW

**Register 0x1D: GPIO Write Register**

Bit 7	Bit 6	Bit 5	Bit 4	Bit 3	Bit 2	Bit 1	Bit 0
Unused						GPIO_WRITE	GPIO_WR_MODE

The GPIO\_WR\_MODE bit reconfigures the SDO pin to a general-purpose input/output (GPIO) port that can be written by the GPIO\_WRITE register or read by the GPIO\_READ register.

**Table 26. SPAREWR0 Configuration Register Bit Descriptions**

Bits	Bit Name	Description	Reset	Access
1	GPIO_WRITE	Data bit is put onto the SDO pin when GPIO write mode is active.	0x00	RW
0	GPIO_WR_MODE	Write b'1 to this register to activate GPIO write mode.	0x00	RW

**Register 0x1E: GPIO Read Register**

Bit 7	Bit 6	Bit 5	Bit 4	Bit 3	Bit 2	Bit 1	Bit 0
Unused							GPIO_READ

**Table 27. SPARERD0 Configuration Register Bit Descriptions**

Bits	Bit Name	Description	Reset	Access
0	GPIO_READ	This register reflects the logic level placed on SDO when a b'0 is written to GPIO_WR_MODE.	0x00	R

### OUTLINE DIMENSIONS

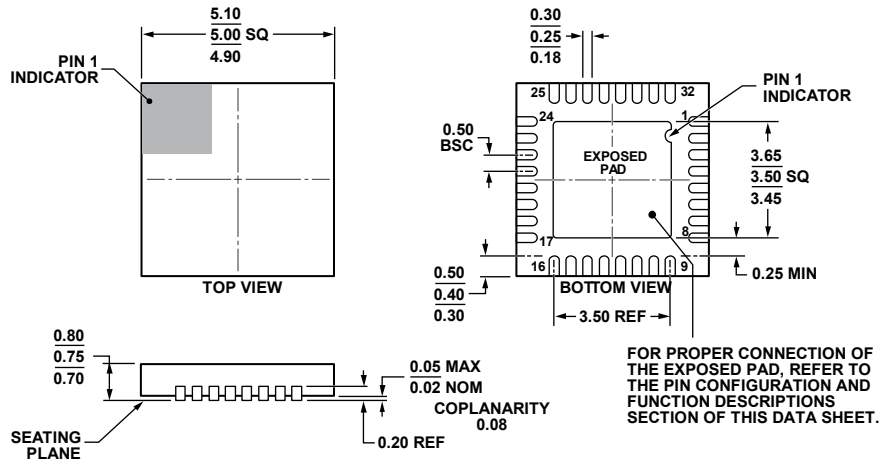

COMPLIANT TO JEDEC STANDARDS MO-220-WHHD.

Figure 31. 32-Lead Lead Frame Chip Scale Package [LFCSP\_WQ]  
 5 mm × 5 mm Body, Very Very Thin Quad  
 (CP-32-11)  
 Dimensions shown in millimeters

04-02-2012-A

### ORDERING GUIDE

Model <sup>1,2</sup>	Temperature Range	Package Description	Package Option
ADA8282WBCPZ-R7	-40°C to +125°C	32-Lead LFCSP_WQ, 7" Tape and Reel	CP-32-11
ADA8282WBCPZ	-40°C to +125°C	32-Lead LFCSP_WQ	CP-32-11
ADA8282CP-EBZ		Evaluation Board	

<sup>1</sup> Z = RoHS Compliant Part.

<sup>2</sup> W = Qualified for Automotive Applications.

### AUTOMOTIVE PRODUCTS

The [ADA8282W](#) models are available with controlled manufacturing to support the quality and reliability requirements of automotive applications. Note that these automotive models may have specifications that differ from the commercial models; therefore, designers should review the Specifications section of this data sheet carefully. Only the automotive grade products shown are available for use in automotive applications. Contact your local Analog Devices account representative for specific product ordering information and to obtain the specific Automotive Reliability reports for these models.



Компания «ЭлектроПласт» предлагает заключение долгосрочных отношений при поставках импортных электронных компонентов на взаимовыгодных условиях!

Наши преимущества:

- Оперативные поставки широкого спектра электронных компонентов отечественного и импортного производства напрямую от производителей и с крупнейших мировых складов;
- Поставка более 17-ти миллионов наименований электронных компонентов;
- Поставка сложных, дефицитных, либо снятых с производства позиций;
- Оперативные сроки поставки под заказ (от 5 рабочих дней);
- Экспресс доставка в любую точку России;
- Техническая поддержка проекта, помощь в подборе аналогов, поставка прототипов;
- Система менеджмента качества сертифицирована по Международному стандарту ISO 9001;
- Лицензия ФСБ на осуществление работ с использованием сведений, составляющих государственную тайну;
- Поставка специализированных компонентов (Xilinx, Altera, Analog Devices, Intersil, Interpoint, Microsemi, Aeroflex, Peregrine, Syfer, Eurofarad, Texas Instrument, Miteq, Cobham, E2V, MA-COM, Hittite, Mini-Circuits, General Dynamics и др.);

Помимо этого, одним из направлений компании «ЭлектроПласт» является направление «Источники питания». Мы предлагаем Вам помощь Конструкторского отдела:

- Подбор оптимального решения, техническое обоснование при выборе компонента;
- Подбор аналогов;
- Консультации по применению компонента;
- Поставка образцов и прототипов;
- Техническая поддержка проекта;
- Защита от снятия компонента с производства.



#### Как с нами связаться

**Телефон:** 8 (812) 309 58 32 (многоканальный)

**Факс:** 8 (812) 320-02-42

**Электронная почта:** [org@eplast1.ru](mailto:org@eplast1.ru)

**Адрес:** 198099, г. Санкт-Петербург, ул. Калинина, дом 2, корпус 4, литера А.