

General Description

The QPL6202Q is a flat-gain, high-linearity, ultra-low noise amplifier in a small 2 x 2 mm surface-mount package. At 2.3 GHz, the amplifier typically provides 21.8 dB gain, +39.9 dBm OIP3 at a 55 mA bias setting, and 0.52 dB noise figure. The LNA can be biased from a single positive supply ranging from 3.3 to 5.25 volts. The device is housed in a green/RoHS-compliant industry-standard 2x2 mm package.

The QPL6202Q uses a high performance E-pHEMT process. The low noise amplifier contains an internal active bias to maintain high performance over temperature. This LNA integrates a shutdown biasing capability to allow for operation in TDD applications.

Functional Block Diagram

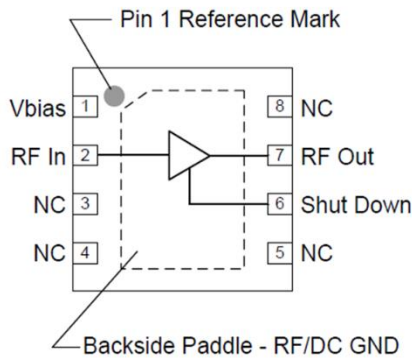

Top View



Package: DFN, 8-pin
2.0mm x 2.0mm x 0.85mm

Product Features

- Tested to AEC-Q100 Grade 2
- Ultra-low noise figure, 0.52 dB NF @ 2.3 GHz
- >20 dB gain across SDARS
- Bias adjustable for linearity optimization
- High input power ruggedness, >32 dBm Pin Max
- +39.9 dBm OIP3 at 55mA I_{DD}
- Unconditionally stable
- Integrated shutdown control pin
- Maintains OFF state with high Pin drive
- +3.3V to +5.25V supply; does not require -V_{gg}

Applications

- SDARS

Ordering Information

Part No.	Description
QPL6202QSB	5 PC SAMPLE BAG
QPL6202QSQ	25 PIECE SAMPLE BAG
QPL6202QSR	100 PIECE 7" SAMPLE REEL
QPL6202QTR7	2500 PIECE 7" SAMPLE REEL
QPL6202QPCK-01	EVALUATION BOARD + 5 PC SAMPLE BAG

Absolute Maximum Ratings

Parameter	Rating
Storage Temperature	-65 to +150 °C
Supply Voltage	+7V
RF Input Power, CW, 50 Ω, T=25 °C	+33 dBm
RF Input Power, WCDMA, 10dB PAR	+27 dBm
RF Input Power, CW, OFF State	+33 dBm

Exceeding any one or a combination of the Absolute Maximum Rating conditions may cause permanent damage to the device. Extended application of Absolute Maximum Rating conditions to the device may reduce device reliability.

Recommended Operating Conditions

Parameter	Min	Typ	Max	Units
Supply Voltage (V _{DD})	3.3	4.5	5.25	V
Bias Voltage (V _{bias})	3.3	3.6	5.25	V
TCASE	-40		+105	°C
T _j for >10 ⁶ hours MTTF			+190	°C

Electrical specifications are measured at specified test conditions. Specifications are not guaranteed over all recommended operating conditions.

Electrical Specifications at +25 °C

Parameter	Conditions	Min	Typ	Max	Units
Operational Frequency Range		2320		2345	MHz
Test Frequency			2332		MHz
Gain		21.2	21.8	23.5	dB
Input Return Loss			8.5		dB
Output Return Loss			17		dB
Noise Figure ¹			0.52	0.75	dB
Output P1dB		+17	+19.9		dBm
Output IP3	P _{out} =+2 dBm/tone, Δf=1 MHz	+30	+39.9		dBm
Power Shutdown Control (pin 6)	On state	0		0.63	V
	Off state (Power down)	1.17		V _{DD}	V
Current, I _{DD} ²	On state	38	55	68	mA
	Off state (Power down)		2.8	5	mA
Shutdown pin current, I _{SD}	V _{PD} ≥ 1.17 V		58		μA
Switching Speed	LNA ON to OFF		583		ns
	LNA OFF to ON		216		ns
Thermal Resistance, θ _{jc}	channel to case		48		°C/W

Test conditions unless otherwise noted: V_{DD} = +4.5V, V_{bias} = +3.6V, Temp=+25°C, 2332MHz, 50 Ω system

Note: **1)** Noise Figure data has input trace loss de-embedded

2) I_{cq} set by external 3.6K resistor

Applications Schematic

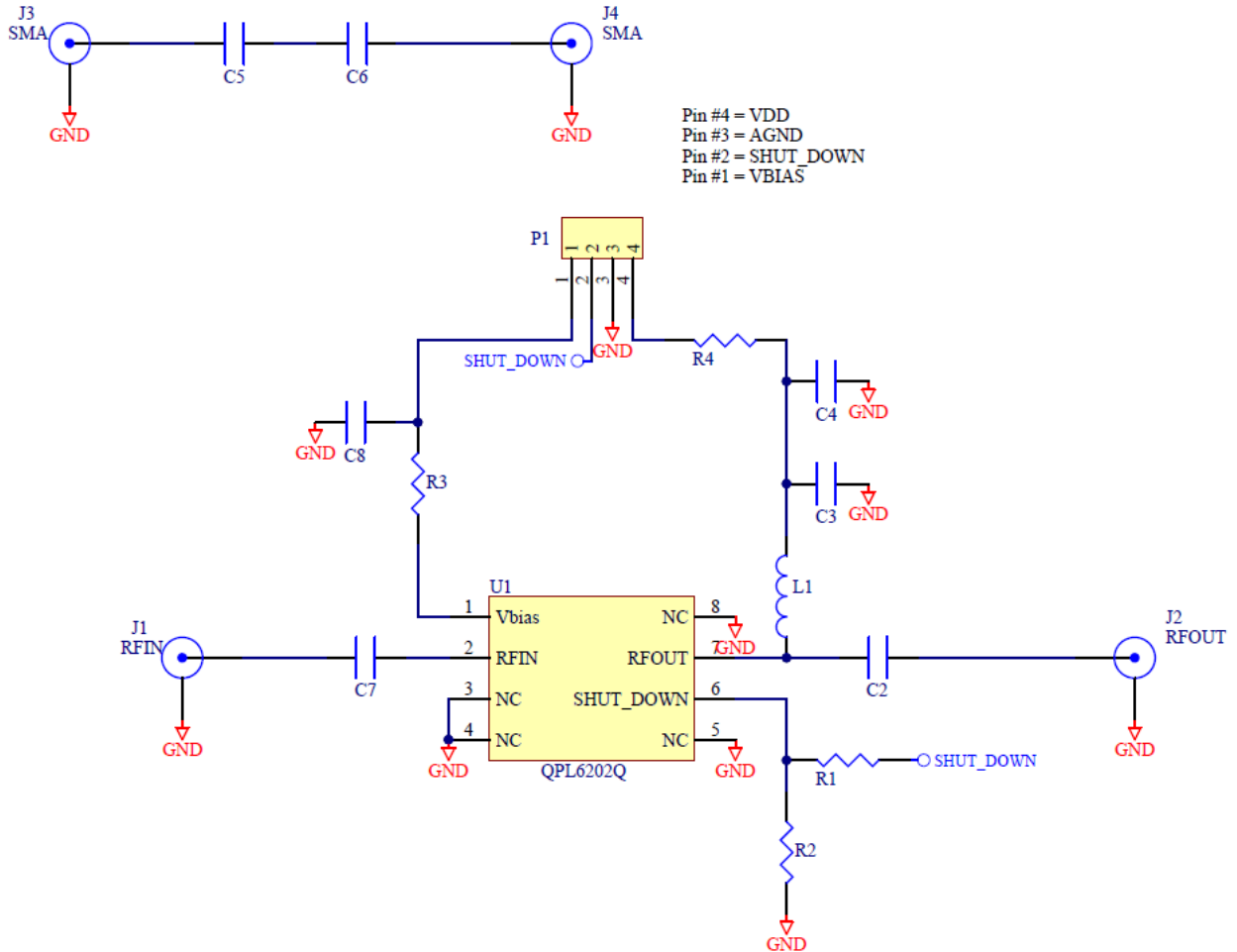

Qty	Ref Des	Description	UOM
1	U1	Hi Gain SDARS	EA
1		PCB, QPL6202	EA
5	C2,C5,C6,C7,C8	CAP, 100pF, 5%, 50V, C0G, 0402	EA
1	C3	CAP, 1000pF, 10%, 50V, X7R, 0402	EA
1	C4	CAP, 1uF, 10%, 6.3V, X7R, 0402	EA
2	R1,R4	RES, 0 OHM, 5%, 1/10W, 0402	EA
1	R3	RES, 3.6K, 5%, 1/16W, 0402	EA
1	R2	RES, 20K, 5%, 1/16W, 0402	EA
1	L1	IND, 18nH, 5%, M/L, 0402	EA
4	J1,J2,J3,J4	862000-422 CONN .062 RF SMA F STRT FLANG	EA
1	P1	CONN, HDR, ST, PLRZD, 4-PIN, 0.100"	EA

Vbias=3.6V	Icq	40mA	50mA	60mA	70mA	80mA
Vdd=4.5V	R3	7K	4.9K	3.5K	2.7K	2.1K

Pin Configuration and Description

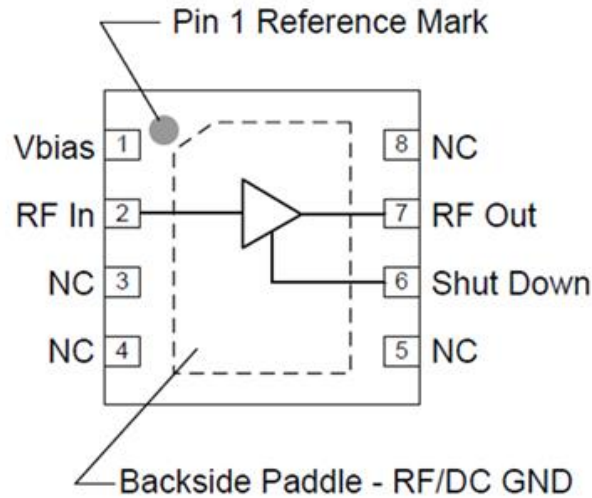

Top View

Pad No.	Label	Description
1	Vbias	Sets the Icq bias point for the device.
2	RF In	RF Input pin. A DC Block is required.
6	Shut Down	A high voltage (>1.17V) turns off the device. If the pin is pulled to ground or driven with a voltage less than 0.63V, then the device will operate under LNA ON state.
7	RF Out / DCBias	RF Output pin. DC bias will also need to be injected through a RF bias choke/inductor for operation.
3, 4, 5, 8	NC	No electrical connection. Provide grounded land pads for PCB mounting integrity.
Backside Paddle	RF/DC GND	RF/DC ground. Use recommended via pattern to minimize inductance and thermal resistance; see PCB Mounting Pattern for suggested footprint.

Performance Plots

Test conditions unless otherwise noted: $V_{DD}=+4.5\text{ V}$, $I_{DD} = 50\text{mA}$, $\text{Temp}=+25^\circ\text{C}$. Noise figure data has input trace loss de-embedded.

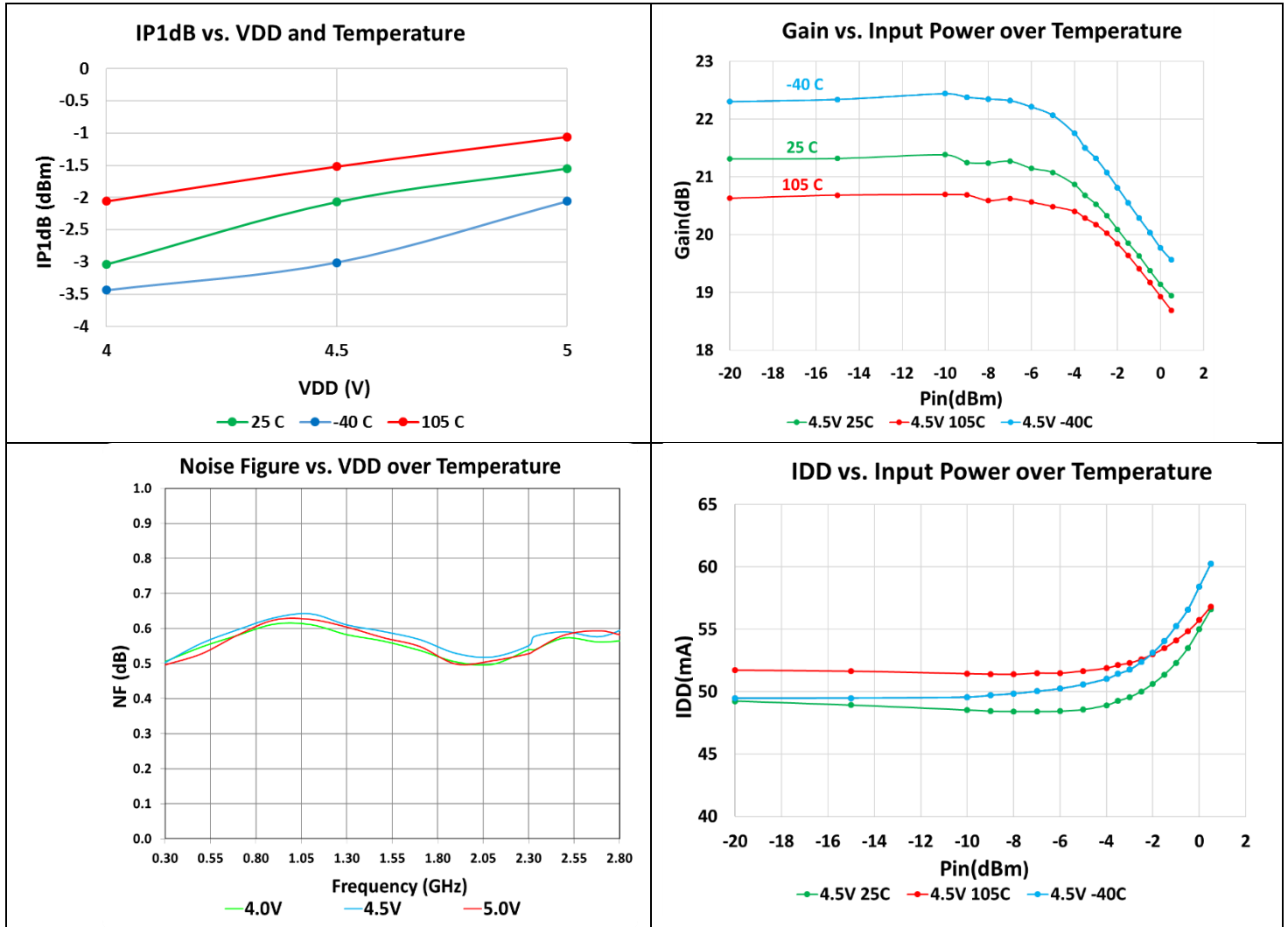

Mechanical Information

Marking: Part number – 6202Q

Trace Code – XXXX

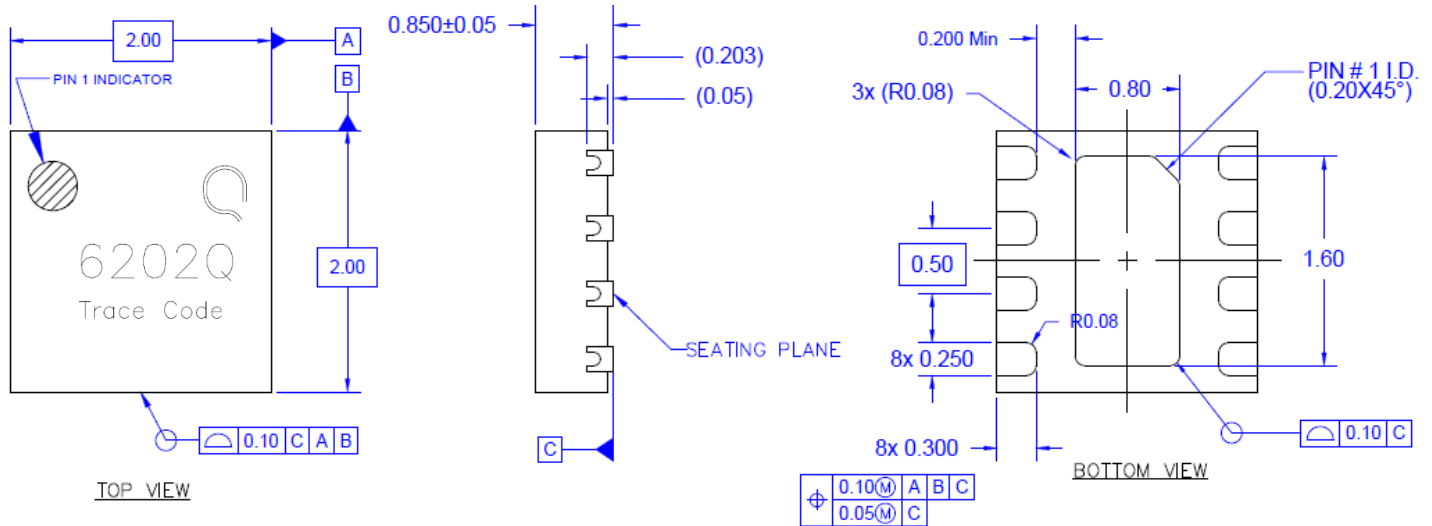

NOTES:

1. All dimensions are in millimeters. Angles are in degrees.
2. Except where noted, this part outline conforms to JEDEC standard MO-220, Issue E (Variation VGGC) for thermally enhanced plastic very thin fine pitch quad flat no lead package (QFN).
3. Dimension and tolerance formats conform to ASME Y14.4M-1994.
4. The terminal #1 identifier and terminal numbering conform to JESD 95-1 SPP-012.

PCB Mounting Pattern

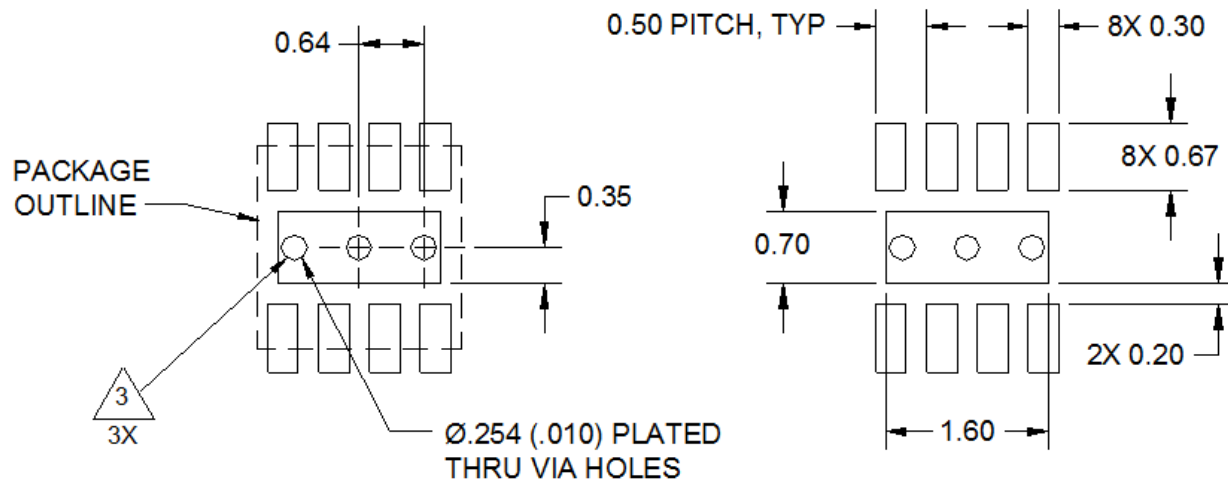

Notes:

1. All dimensions are in millimeters. Angles are in degrees.
2. Use 1 oz. copper minimum for top and bottom layer metal.
3. Vias are required under the backside paddle of this device for proper RF/DC grounding and thermal dissipation. We recommend a 0.35mm (#80/.0135") diameter bit for drilling via holes and a final plated thru diameter of 0.25 mm (0.10").
4. Ensure good package backside paddle solder attach for reliable operation and best electrical performance.

Handling Precautions

Parameter	Rating	Standard
ESD – Human Body Model (HBM)	Class 1B	JS-001
ESD – Charged Device Model (CDM)	Class C3	JS-002
MSL – Moisture Sensitivity Level	Level 1	IPC/JEDEC J-STD-020



Caution!
 ESD-Sensitive Device

Solderability

Compatible with both lead-free (260°C max. reflow temp.) and tin/lead (245°C max. reflow temp.) soldering processes. Solder profiles available upon request. Contact plating: NiPdAu

RoHS Compliance

This part is compliant with EU 2002/95/EC RoHS directive (Restrictions on the Use of Certain Hazardous Substances in Electrical and Electronic Equipment). This product also has the following attributes:

- Lead Free
- Halogen Free (Chlorine, Bromine)
- Antimony Free
- TBBP-A (C₁₅H₁₂Br₄O₂) Free
- PFOS Free
- SVHC Free

Contact Information

For the latest specifications, additional product information, worldwide sales and distribution locations:

Tel: 1-844-890-8163

Web: www.qorvo.com

Email: customer.support@qorvo.com

Important Notice

The information contained herein is believed to be reliable; however, Qorvo makes no warranties regarding the information contained herein and assumes no responsibility or liability whatsoever for the use of the information contained herein. All information contained herein is subject to change without notice. Customers should obtain and verify the latest relevant information before placing orders for Qorvo products. The information contained herein or any use of such information does not grant, explicitly or implicitly, to any party any patent rights, licenses, or any other intellectual property rights, whether with regard to such information itself or anything described by such information. **THIS INFORMATION DOES NOT CONSTITUTE A WARRANTY WITH RESPECT TO THE PRODUCTS DESCRIBED HEREIN, AND QORVO HEREBY DISCLAIMS ANY AND ALL WARRANTIES WITH RESPECT TO SUCH PRODUCTS WHETHER EXPRESS OR IMPLIED BY LAW, COURSE OF DEALING, COURSE OF PERFORMANCE, USAGE OF TRADE OR OTHERWISE, INCLUDING THE IMPLIED WARRANTIES OF MERCHANTABILITY AND FITNESS FOR A PARTICULAR PURPOSE.**

Without limiting the generality of the foregoing, Qorvo products are not warranted or authorized for use as critical components in medical, life-saving, or life-sustaining applications, or other applications where a failure would reasonably be expected to cause severe personal injury or death.

Copyright 2016 © Qorvo, Inc. | Qorvo is a registered trademark of Qorvo, Inc.



Компания «ЭлектроПласт» предлагает заключение долгосрочных отношений при поставках импортных электронных компонентов на взаимовыгодных условиях!

Наши преимущества:

- Оперативные поставки широкого спектра электронных компонентов отечественного и импортного производства напрямую от производителей и с крупнейших мировых складов;
- Поставка более 17-ти миллионов наименований электронных компонентов;
- Поставка сложных, дефицитных, либо снятых с производства позиций;
- Оперативные сроки поставки под заказ (от 5 рабочих дней);
- Экспресс доставка в любую точку России;
- Техническая поддержка проекта, помощь в подборе аналогов, поставка прототипов;
- Система менеджмента качества сертифицирована по Международному стандарту ISO 9001;
- Лицензия ФСБ на осуществление работ с использованием сведений, составляющих государственную тайну;
- Поставка специализированных компонентов (Xilinx, Altera, Analog Devices, Intersil, Interpoint, Microsemi, Aeroflex, Peregrine, Syfer, Eurofarad, Texas Instrument, Miteq, Cobham, E2V, MA-COM, Hittite, Mini-Circuits, General Dynamics и др.);

Помимо этого, одним из направлений компании «ЭлектроПласт» является направление «Источники питания». Мы предлагаем Вам помощь Конструкторского отдела:

- Подбор оптимального решения, техническое обоснование при выборе компонента;
- Подбор аналогов;
- Консультации по применению компонента;
- Поставка образцов и прототипов;
- Техническая поддержка проекта;
- Защита от снятия компонента с производства.



Как с нами связаться

Телефон: 8 (812) 309 58 32 (многоканальный)

Факс: 8 (812) 320-02-42

Электронная почта: org@eplast1.ru

Адрес: 198099, г. Санкт-Петербург, ул. Калинина, дом 2, корпус 4, литера А.