

DESCRIPTION

The MP2676 is a highly integrated circuit designed to provide complete Li-ion battery charger protection against input over voltage, input over current and battery over voltage. The IC continuously monitors the input voltage, the input current and the battery voltage, when any of the monitored parameters exceeds its threshold, the IC immediately turns off the internal N-channel MOSFET to remove the power from the charge system before any damage occurs. Moreover, all protections also have blanking times against false triggering due to voltage spikes or current transients. The IC also features thermal shutdown protection, if the temperature exceeds 140°C, MP2676 will turn off the internal MOSFET bridging ACIN and CHRIN.

MP2676 integrates a P-channel MOSFET with the body diode reverse protection to replace the external P-channel MOSFET and blocking diode for charge function of portable devices with PMIC (Power Management IC). The above features and small package make the MP2676 an ideal part for portable applications.

FEATURES

- No External Blocking Diode Requiring
- Input Over Voltage Protection in 1 μ s
- Input Over Current Protection
- Battery Over Voltage Protection
- Integrated Charging MOSFET
- Temperature Monitoring and Protection
- High Immunity of False Triggering under Startup, Transients

APPLICATIONS

- Cell Phones
- MP3 Players
- Smart Phones
- PDAs
- Digital Cameras
- Desktop Chargers

"MPS" and "The Future of Analog IC Technology" are Registered Trademarks of Monolithic Power Systems, Inc.

TYPICAL APPLICATION

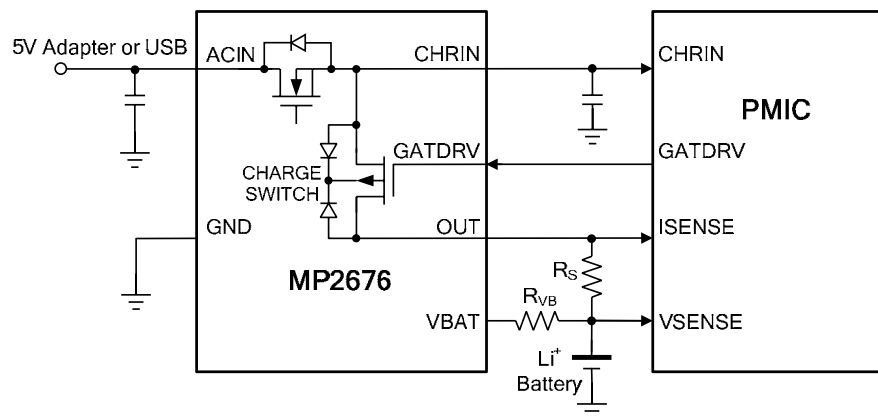

ORDERING INFORMATION

Part Number*	Package	Top Marking	Free Air Temperature (T _A)
MP2676EG	QFN8 (2mm x 2mm)	8Q	-20°C to +85°C

* For Tape & Reel, add suffix -Z (e.g. MP2676EG-Z)
 For RoHS compliant packaging, add suffix -LF (e.g. MP2676EG-LF-Z)

PACKAGE REFERENCE

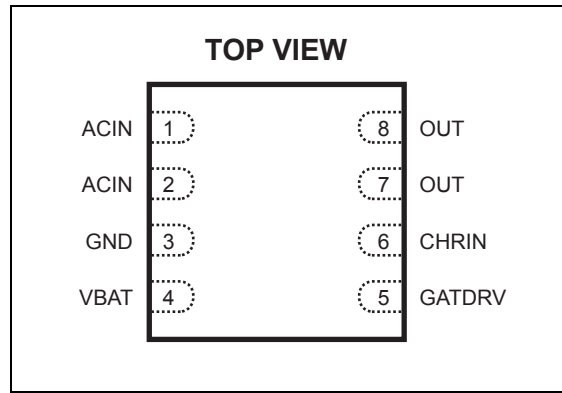

ABSOLUTE MAXIMUM RATINGS ⁽¹⁾

ACIN to GND.....-0.3V to 30V
 OUT, GATDRV and CHRIN to GND

.....-0.3V to 7V

VBAT-0.3V to 5.5V

Continuous Power Dissipation (T_A = +25°C)
⁽²⁾

QFN8 (2mm x 2mm) 1.25W

Junction Temperature..... 150°C

Storage Temperature..... -65°C to +150°C

Lead Temperature260°C

Recommended Operating Conditions ⁽³⁾

Supply Voltage V_{IN} 4.3V to 5.5V

Operating Junct. Temp (T_J)..... -20°C to +125°C

Thermal Resistance ⁽⁴⁾ **θ_{JA}** **θ_{JC}**
 QFN8 (2mm x 2mm)..... 10055... °C/W

Notes:

- 1) Exceeding these ratings may damage the device.
- 2) The maximum allowable power dissipation is a function of the maximum junction temperature T_J(MAX), the junction-to-ambient thermal resistance θ_{JA}, and the ambient temperature T_A. The maximum allowable continuous power dissipation at any ambient temperature is calculated by P_D(MAX)=(T_J(MAX)-T_A)/θ_{JA}. Exceeding the maximum allowable power dissipation will cause excessive die temperature, and the regulator will go into thermal shutdown. Internal thermal shutdown circuitry protects the device from permanent damage.
- 3) The device is not guaranteed to function outside of its operating conditions.
- 4) Measured on JESD51-7, 4-layer PCB.

ELECTRICAL CHARACTERISTICS

Typical values at $V_{IN} = 5V$, $T_A = +25^{\circ}C$, unless otherwise noted.

Parameter	Symbol	Condition	Min	Typ	Max	Units
Rising V_{IN} Threshold	UVLO		2.5	2.65	2.8	V
POR Hysteresis				130		mV
Input Power On Blanking time	$T_{REC(vout)}$	V_{ACIN} Rising to V_{OUT} Rising		10		ms
Operating Current	I_{IN}	No Load on OUT and CHRIN pin		500	600	μA
Reverse Current		ACIN Float, GATDRV = OUT = 7V		1	10	μA
Input Over Voltage Protection (OVP)	V_{OVP}		5.8	6.0	6.25	V
Input OVP Hysteresis				35		mV
Input OVP Falling Threshold			5.75			V
Input OVP Propagation Delay					1	μs
IOVP Recovery Time	$T_{REC(IOVP)}$			10		ms
Over Current Protection	I_{OCP}		1.3	1.6	2	A
OCP Blanking Time				180		μs
Battery Over Voltage Protection Threshold			4.25	4.35	4.475	V
BOVP Hysteresis				240		mV
BOVP Falling Threshold			4	4.12	4.2	V
Battery OVP Blanking Time				200		μs
OTP Rising Threshold				140		$^{\circ}C$
OTP Hysteresis				20		$^{\circ}C$
ACIN to OUT On Resistance	R_{ON}	$I_{IN}=500mA$, $4.3V < ACIN < 5.5V$		450		$m\Omega$

PIN FUNCTIONS

Pin #	Name	Description
1, 2	ACIN	Input Power Source, ACIN can withstand 30V input surge.
3	GND	System Ground
4	VBAT	Battery Voltage Monitoring Input. Connect this pin to the battery pack positive terminal via an isolation resistor
5	GATDRV	External control pin for controlling the P-channel MOSFET by charge controller
6	CHRIN	Voltage is equal to ACIN if ACIN is in power good range.
7, 8	OUT	Output Pin. Connect this pin to the battery pack positive terminal via a sense resistor.

TYPICAL PERFORMANCE CHARACTERISTICS

$V_{IN}=5V$, $R_{VB}=200k\Omega$, GATDRV connected to GND, $T_A=25^\circ C$, unless otherwise noted.

Supply Current vs. V_{IN}

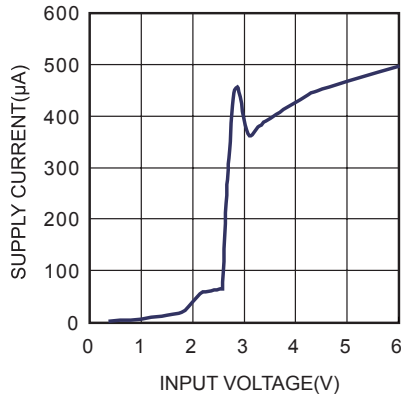

Breakdown Voltage

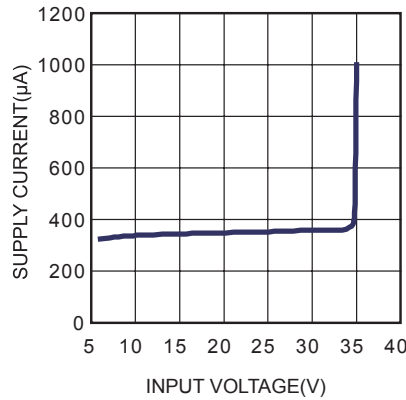

Output Reverse Current vs. V_{OUT}

No Input, $V_{BAT}=GND$, $V_{OUT}=1V$ to $4.2V$

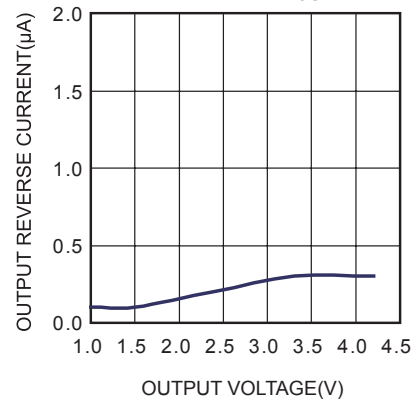

ACIN to OUT On Resistance vs. V_{IN}

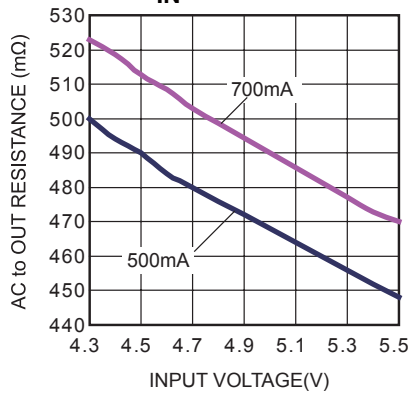

Power On through V_{IN}

No load at OUT and CHRIN

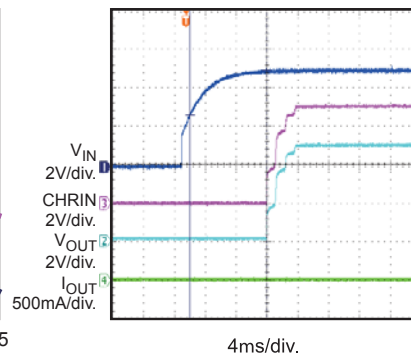

Power Down through V_{IN}

No load at OUT and CHRIN

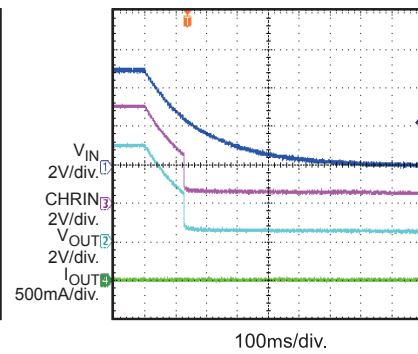

Power Up through V_{IN}

5.1Ω Resistive Load at OUT

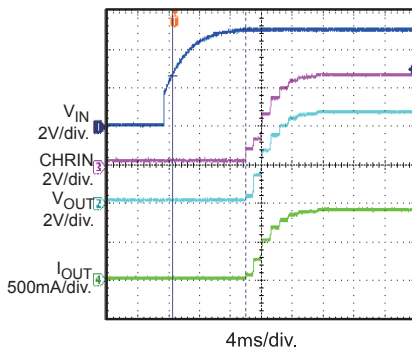

Power Down through V_{IN}

5.1Ω Resistive Load at OUT

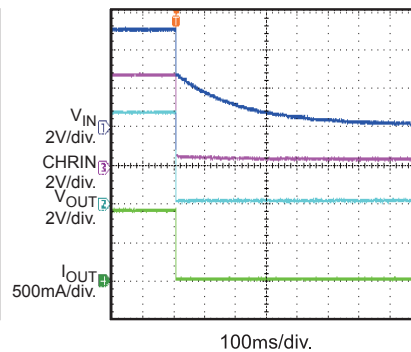

Input OVP

V_{IN} Steps from 5V to 7V Slowly, GATDRV=CHRIN

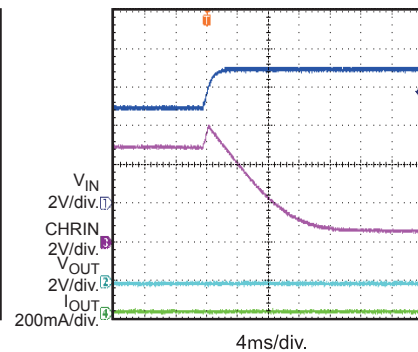

TYPICAL PERFORMANCE CHARACTERISTICS (continued)
 $V_{IN}=5V$, $R_{VB}=200k\Omega$, GATDRV connected to GND, $T_A=25^\circ C$, unless otherwise noted.

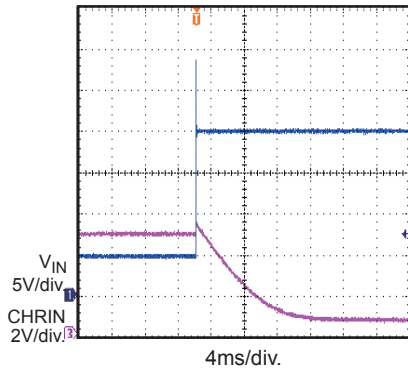
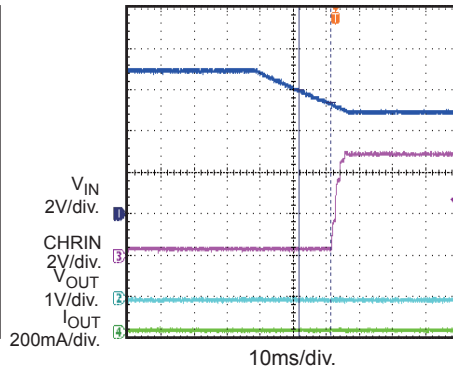
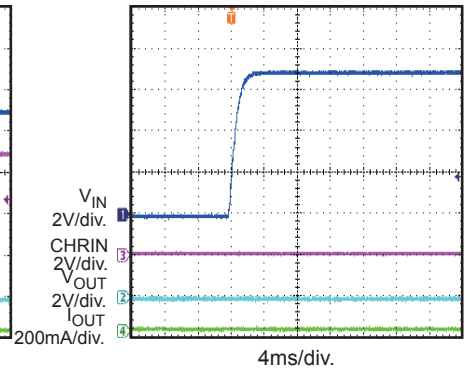
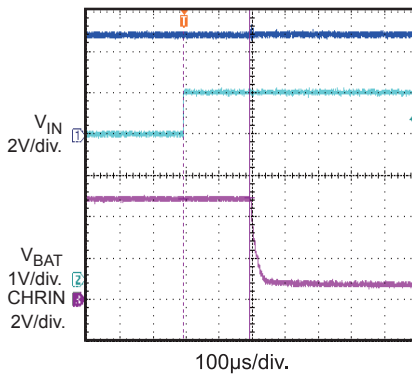
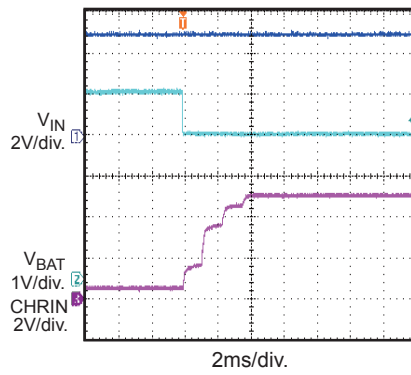
Input OVP
 V_{IN} Steps from 5V to 20V Quickly,
GATDRV=CHRIN

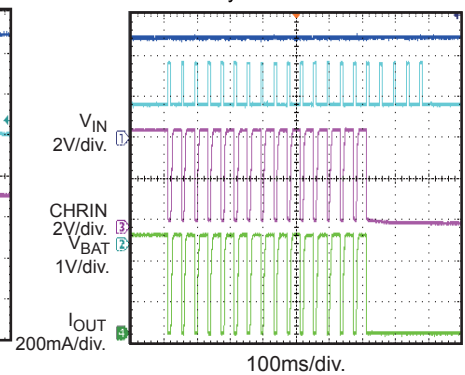
Input OVP Recovery
 V_{IN} Drops from 7V to 5V Slowly,
GATDRV=CHRIN

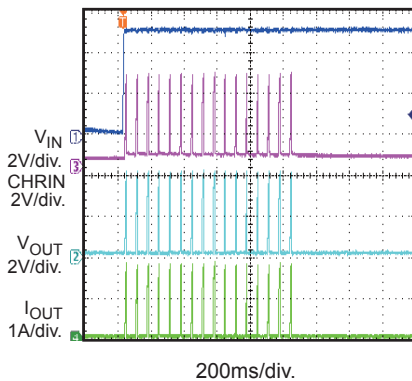
Input OVP Start Up
 $V_{IN}=7V$, GATDRV=CHRIN

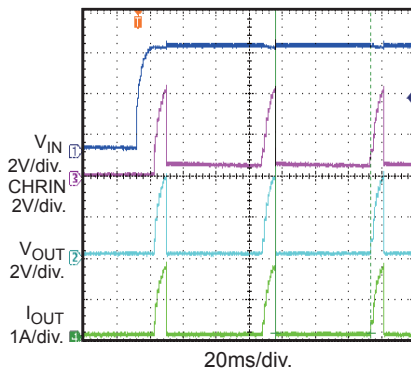
Battery OVP Blanking Time
 V_{BAT} Steps from 3.5V to 4.5V

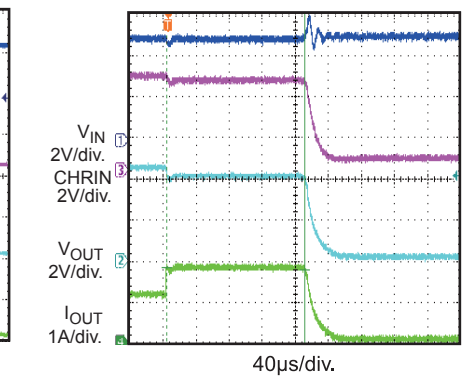
Battery OVP Recovery
 V_{BAT} Drops from 4.5V to 3.5V

Battery OVP

 10Ω Resistive Load at OUT, Shut Down
 Permanently after 16 times

OCP Before Start Up

 Connect 1Ω Resistive Load from
 OUT to GND before Start Up

Zoom In of OCP

 Connect 1Ω Resistive Load from
 OUT to GND

OCP Blanking Time

 Connect a 5.1Ω parallel resistor from
 OUT to GND with 3.9Ω connected

BLOCK DIAGRAM

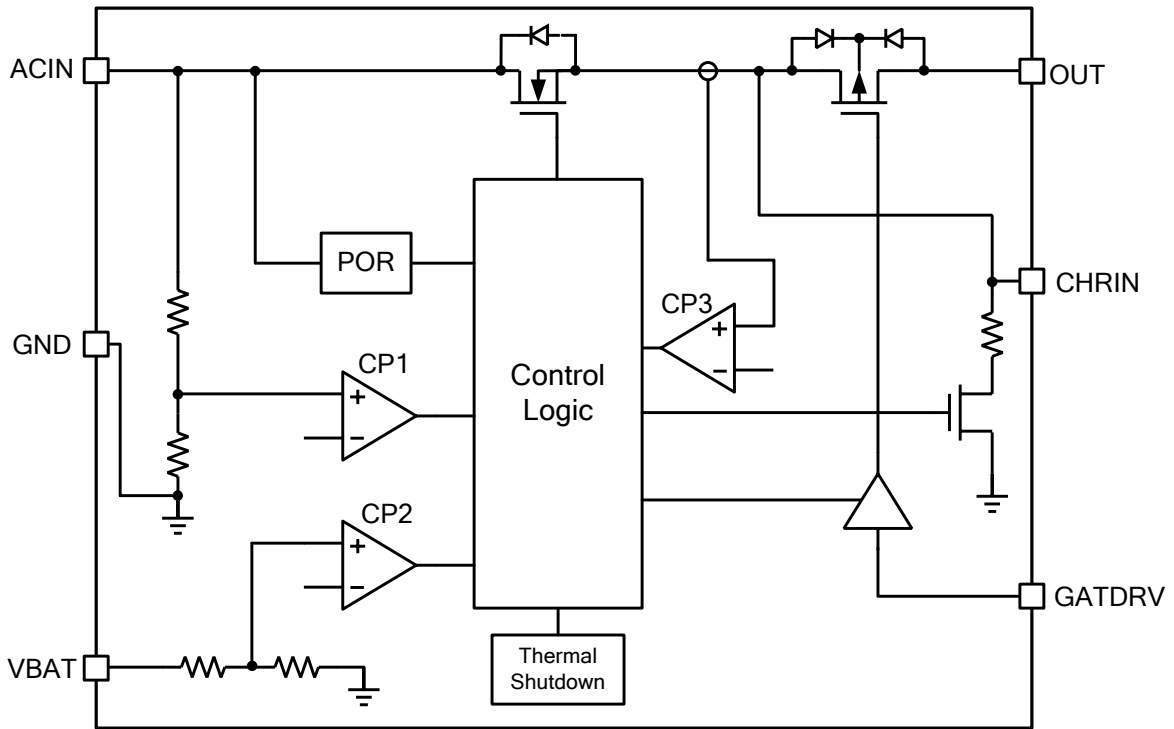

Figure 1—Function Block Diagram

OPERATION

The MP2676 is a highly integrated circuit designed to provide complete Li-ion battery charger protection against input over voltage, input over current and battery over voltage. The IC continuously monitors the input voltage, the input current and the battery voltage, when any of the monitored parameters exceeds its threshold, the IC immediately turns off the internal N-channel MOSFET to remove the power from the charge system before any damage occurs. Moreover, all protections also have blanking times against false triggering due to voltage spikes or current transients. The IC also features thermal shutdown protection, if the temperature exceeds 140°C, MP2676 will turn off the internal MOSFET bridging ACIN and CHRIN.

MP2676 integrates a P-channel MOSFET with the body diode reverse protection to replace the external P-channel MOSFET and block diode for charge function of portable devices with PMIC (Power Management IC).

Power Up

The MP2676 has a power-on reset (POR) threshold of 2.65V with a built-in hysteresis of 130mV. When the input voltage is below the POR threshold, the internal N-channel MOSFET is off. The IC resets itself and waits for about 10ms after the input voltage exceeds the POR threshold, then, if the input voltage and battery voltage are safe, the IC begins to soft-start the internal N-channel MOSFET. The 10ms delay allows any transient at the input during a hot insertion of the power supply to settle down before the IC starts to operate. The soft-start slowly turns on the N-channel MOSFET to reduce the inrush current as well as the input voltage drop during the transition.

Input Over-voltage Protection (OVP)

The input voltage is continuously monitored by the internal comparator CP1 in the block diagram (Figure 1), the OVP threshold is set by an internal resistive divider and an accurate reference generated by the IC itself. The protection threshold is set to 6V. When the input voltage exceeds the threshold, the CP1 outputs a logic signal to turn off the N-channel

MOSFET within 1 μ s to prevent the high input voltage from damaging the electronics in the handheld system. The hysteresis of the input OVP threshold is given in the Electrical Characteristic. When the input over-voltage condition is removed, the N-channel MOSFET is turned on again by running through the soft-start. Because of the 10ms delay before the soft-start, the output is never enabled if the input rises above the OVP threshold within 10ms.

Battery Over-voltage Protection (BOVP)

The battery voltage OVP threshold is internally set to 4.35V, and the threshold has 240mV built-in hysteresis. When the battery voltage exceeds the battery OVP threshold, the internal comparator CP2 has a built-in 200 μ s blanking time to prevent any transient voltages from triggering the BOVP. If the BOVP situation still exists after the blanking time, the N-channel MOSFET is turned off. There is an internal 4-bit binary counter monitoring the occurrences of the BOVP event. If the BOVP event occurs 16 times, the N-channel MOSFET is turned off permanently. Recycling the input power will reset the counter and restart the MP2676.

Over-current Protection (OCP)

The current through the N-channel MOSFET is limited to prevent charging the battery with an excessive current. The current limit threshold is preset to 1.6A. The OCP comparator CP3 has a built-in 180 μ s delay to prevent false triggering by transient signals. When OCP happened, VOUT shuts down and takes 60ms delay to soft start as the OCP condition is removed. The OCP function also has a 4-bit binary counter that accumulates the occurrences of OCP event. When the total count reaches 16, the N-channel MOSFET is turned off permanently unless the input power is recycled.

Thermal Protection

The MP2676 monitors its own die temperature to prevent thermal failures. When the internal temperature reaches 140°C, the internal N-channel MOSFET is turned off. The IC does not resume operation until the internal temperature drops below 120°C

APPLICATION INFORMATION

For safe and effective charging, some strict requirements have to be satisfied during charging Li-ion batteries such as high precise power source for charging ($4.2V \pm 50mV$), the accuracy should be higher than 1%. For highly used capacity, the voltage of the battery should be charged to the value (4.2V) as possible as could. Otherwise, the performance and the life of the battery suffers overcharge. Additionally, the pre-charge for depleted batteries, charge voltage, charge current, as well as the temperature detection and protection, are required for linear battery chargers. MP2676 provides full protection to guarantee the safety of the charge system with its perfect four protection functions: OVP, BOVP, OCP and OTP.

An internal P-channel MOSFET is integrated to the MP2676, which can be controlled by the external control signal from PMIC to achieve charging function including CC, CV charge mode and so on. Particularly, connecting GATDRV to GND can turn on the P-channel MOSFET while connecting GATDRV to CHRIN can fully turn off the P-channel MOSFET.

C_{IN} and C_{OUT} Selection

The input capacitor (C_{IN}) is for decoupling and serves an important role. Higher value of C_{IN} reduces the voltage undershoot or overshoot during transients. The AC adapter is inserted live (hot insertion) and sudden step down of the current in the power MOSFET will cause the input voltage overshoot.

During an input OVP, the N-channel MOSFET is turned off in less than 1 μ s and can lead to significant overshoot. Higher capacitance of C_{IN} reduces this type of overshoot. However, the overshoot caused by a hot insertion is not very dependent on the decoupling capacitance value. Usually, the input decoupling capacitor is recommended to use a dielectric ceramic capacitor with a value between 1 μ F to 4.7 μ F.

The output of the MP2676 and the input of the charge circuit typically share one decoupling capacitor.

R_{VB} Selection

It is strongly recommended that the battery not be tied directly to the VBAT pin of the device, as under some failure modes of the IC, the voltage at the ACIN pin may appear on the VBAT pin. R_{VB} limits the current from the VBAT pin to the battery terminal in case the MP2676 fails. The recommended value is between 200k Ω to 1M Ω . With 200k Ω resistance, during the failure operation, assuming the VBAT pin voltage is 30V and the battery voltage is 4.2V. The worst case the current flowing from the VBAT pin to the charger output is,

$$(30V - 4.2V)/200k\Omega = 130\mu A,$$

Such small current can be easily absorbed by the bias current of other components. Increasing the R_{VB} value reduces the worst case current, but at the same time increases the error for the 4.35V battery OVP threshold.

As the typical VBAT pin leakage current is 20nA, the error of the battery OVP threshold can be calculated as $4.35V + 20nA \times R_{VB}$. With the 200k Ω resistor, the worst-case additional error is 4mV and with a 1M Ω resistor, the worst-case additional error is 20mV.

PACKAGE INFORMATION

QFN8 (2mmx2mm)

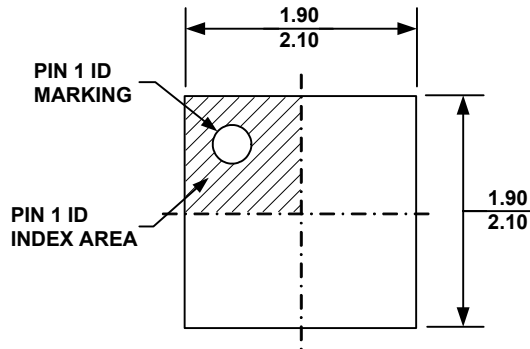

TOP VIEW

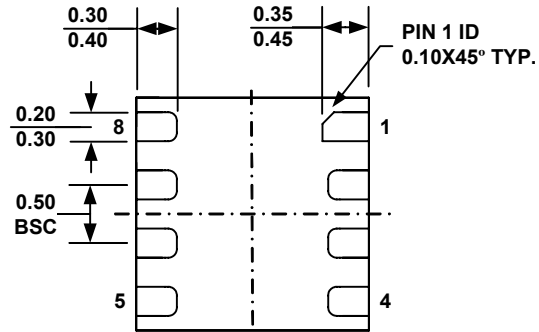

BOTTOM VIEW

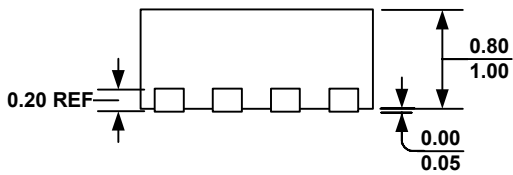

SIDE VIEW

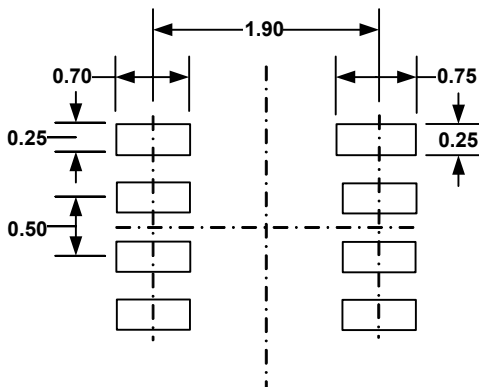

RECOMMENDED LAND PATTERN

NOTE:

- 1) ALL DIMENSIONS ARE IN MILLIMETERS.
- 2) EXPOSED PADDLE SIZE DOES NOT INCLUDE MOLD FLASH.
- 3) LEAD COPLANARITY SHALL BE 0.10 MILLIMETER MAX.
- 4) JEDEC REFERENCE IS MO-220, VARIATION VCCD.
- 5) DRAWING IS NOT TO SCALE.

NOTICE: The information in this document is subject to change without notice. Please contact MPS for current specifications. Users should warrant and guarantee that third party Intellectual Property rights are not infringed upon when integrating MPS products into any application. MPS will not assume any legal responsibility for any said applications.



Компания «ЭлектроПласт» предлагает заключение долгосрочных отношений при поставках импортных электронных компонентов на взаимовыгодных условиях!

Наши преимущества:

- Оперативные поставки широкого спектра электронных компонентов отечественного и импортного производства напрямую от производителей и с крупнейших мировых складов;
- Поставка более 17-ти миллионов наименований электронных компонентов;
- Поставка сложных, дефицитных, либо снятых с производства позиций;
- Оперативные сроки поставки под заказ (от 5 рабочих дней);
- Экспресс доставка в любую точку России;
- Техническая поддержка проекта, помощь в подборе аналогов, поставка прототипов;
- Система менеджмента качества сертифицирована по Международному стандарту ISO 9001;
- Лицензия ФСБ на осуществление работ с использованием сведений, составляющих государственную тайну;
- Поставка специализированных компонентов (Xilinx, Altera, Analog Devices, Intersil, Interpoint, Microsemi, Aeroflex, Peregrine, Syfer, Eurofarad, Texas Instrument, Miteq, Cobham, E2V, MA-COM, Hittite, Mini-Circuits, General Dynamics и др.);

Помимо этого, одним из направлений компании «ЭлектроПласт» является направление «Источники питания». Мы предлагаем Вам помощь Конструкторского отдела:

- Подбор оптимального решения, техническое обоснование при выборе компонента;
- Подбор аналогов;
- Консультации по применению компонента;
- Поставка образцов и прототипов;
- Техническая поддержка проекта;
- Защита от снятия компонента с производства.



Как с нами связаться

Телефон: 8 (812) 309 58 32 (многоканальный)

Факс: 8 (812) 320-02-42

Электронная почта: org@eplast1.ru

Адрес: 198099, г. Санкт-Петербург, ул. Калинина, дом 2, корпус 4, литера А.