

PI3HDX1204E

HDMI 2.0 6Gbps Linear Redriver Level Shifter Near to the Sink/DFE-side application

Description

PI3HDX1204E is the HDMI 2.0 Linear Redriver with the Level Shifter, supporting the minimum additive jitters. The linear Redriver provides the easiness of handling the signal integrity issues known in the component placement and the setting parameters of Equalization and Flat Gain compensation between Source-side and Sink-side link system.

The advantage of Linear Redriver does not block the original source differential signals to maximize the Sink-side Receiver Digital Feedback Equalization (DFE) Feedback circuits to improve the high-speed linked signal quality. The output swing range can set by Swing control for the power saving.

The optimization of the signal quality over a variety of physical mediums by reducing Inter-symbol Interference (ISI) jitters can be done by the pin-strapping or I2C programming.

In EEPROM mode, the Equalization, Voltage Swing and Gain controls can be automatically loaded during the system power-up to eliminate the need of external microprocessor or software driver.

Features

- **HDMI 2.0 Compliant TMDS Linear Redriver with 2x Improved Jitter Performance than conventional technology**
- **DP++ Level Shifting for HDMI output**
- **Linear Redriver increases TMDS Link Margin supporting Sink-side DFE (Decision Feedback Equalizers) receiver**
- **Every Channel's Equalizations, Swings and Gains are programmable Independently**
- **Support Pin- strap and I2C Programming**
- **Flexible 4-bit I2C address selectable (42-pin, ZH package)**
- **Power supply: 3.3V**
- **Package (Pb-Free & Green):**
 - 32-pin TQFN (3x6mm)
 - 42-pin TQFN (3.5x9mm)

Applications

- **TVs and Monitors near to the Sink-side Devices**

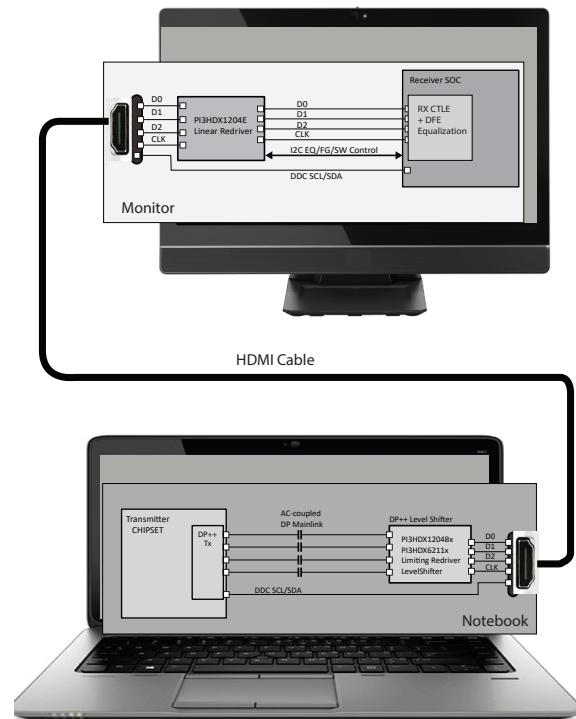

Figure 1. Monitor for sink-side with Rx DFE receiver

Ordering Information

Ordering Number	Package Code	Eco Plan
PI3HDX1204E ZLEX	ZL	Pb-free & Green, 32-pin TQFN
PI3HDX1204E ZHEX	ZH	Pb-free & Green, 42pin TQFN

2. General Information

2.1 Revision History

Revision	Description
March 2016	Pin-out (p8): FGx(x=0,1) Pin name typo fixed.
April 2016	Electrical(p17): tSK_INTRA_OUT changed 5 typ, 10 max ps
May 2016	Application(p30): More informative system EE contents added. DDC source-side pull-up changed to 10 kOhm from 2 kOhm
June 2016	Mechanical (p39): EPAD outline changed
Oct 2016	Diodes Disclaimer added
Aug 2017	Clarified Output Swing range control in functional description. PI3HDX1204B1 limiting and PI3HDX1204E linear pin-out comparison added in generic information session
Dec 2017	Updated package mechanical drawing with latest (p46).

2.2 PI3HDX1204D to PI3HDX1204E PDN Notice

PI3HDX1204E is a production part number of PI3HDX1204D. The detail comparison is summarized below.

	PI3HDX1204E	PI3HDX1204D
Changes	32-pin TQFN package added	EOL (End of Life). PI3HDX1204D was engineering version of PI3HDX1204E
Pin-out	No change	
Function control	No change	
Application Note	PI3HDX1204D application note and schematics are applicable to the PI3HDX1204E.	

2.3 Similar Products Comparison

	PI3HDX1204B1	PI3HDX1204E
Redriver Type	Limiting type	Linear type
EQ at 6Gbps	22 dB	10 dB
Output TMDS peak-to-peak Swing	Output Swing Amplitude / Pre-Emphasis control. Blocking type	Follow Source Swing Amplitude. Non-blocking type.
DDC Switch/Buffer	No	No
HDMI1.4/2.0 Type ID	No	No
Ioff Protection	External Power Switch	External Power Switch
Data Rate (Gbps)	6 Gbps	6 Gbps
Application	Near to Source-side device	Near to Sink-side device
Availability	Production	Production

PI3HDX1204E

PI3HDX1204B1 / PI3HDX1204E Pin out Co-layout Comparison	Connection Description
<p> PI3HDX1204B1 PI3HDX1204E </p>	<p>Pin 16,17,23: Do not connect in PI3HDX1204E Pin 1,2,20,21,22,37,38,39,40,41,42: Pull-up and Pull-down pin mode control pins</p>

2.4 Related Products

Part Numbers	Products Description
Retimers / Jitter Cleaner	
PI3HDX2711B	HDMI 2.0 and DP++ Retimer (Jitter Cleaner)
PI3HDX711B	HDMI 1.4 and DP++ ReTimer (Jitter Cleaner)
Redrivers	
PI3DPX1203B	DisplayPort 1.4 Redriver for Source/Sink/Cable Application, Linear-type
PI3HDX1204B1	HDMI 2.0 Redriver (DP++ Level Shifter), High EQ, place near to the source-side, Limiting type
PI3HDX1204E	HDMI 2.0 Linear Redriver (DP++ Level Shifter) , Link transparent, place near to the sink-side
PI3DPX1207B	DisplayPort 1.4 Alt Type-C Redriver, 8.1 Gbps and USB3.1 10 Gbps, Link Transparent
PI3DPX1202A	Low Power DisplayPort 1.2 Redriver with built-in AUX Listener, Limiting-type
PI3HDX511F	High EQ HDMI 1.4b Redriver and DP++ Level Shifter for Sink/Source Application, Limiting-type
Active Switches & Splitters	
PI3DPX1205A	DisplayPort 1.4 Alt Type-C Mux Redriver, 8.1 Gbps and USB3.1 10 Gbps, Link Transparent
PI3HDX231	HDMI 2.0 3:1 ports Mux Redriver, Linear-type
PI3HDX414	HDMI 1.4b 1:4 Demux Redriver & Splitter for 3.4 Gbps Application, Limiting-type
PI3HDX412BD	HDMI 1.4b 1:2 Demux Redriver & Splitter for 3.4 Gbps Application, Limiting-type
PI3HDX621	HDMI 1.4 Redriver 2:1 Active Switch with built-in ARC and Fast Switching support, Limiting-type

Contents

1. Product Brief	1
2. General Information	2
2.1 Revision History	2
2.2 PI3HDX1204D to PI3HDX1204E PDN Notice	2
2.3 Similar Products Comparison	2
2.4 Related Products	4
3. Pin Configuration	6
3.1 Package Pin-out	6
3.2 Pin Description	7
4. Functional	11
4.1 Functional Block	11
4.2 Function Description	12
5. I2C Programming	16
5.1 Programming registers	16
5.2 I2C operation	18
6. Electrical Specification	20
6.1 Absolute Maximum ratings	20
6.2 Recommended operating conditions	20
6.3 Electrical characteristics	20
6.4 I2C Interface Bus	25
7. Applications	27
7.1 DC/AC-coupled Application	27
7.2 Sink-side Redriver Application	28
7.3 Channels/Polarity Swap	28
7.4 Output Eye Diagram	29
7.5 Layout Guidelines	33
7.6 HDMI 2.0 Compliance Test	39
8. Mechanical/Packaging	42
8.1 Mechanical Outline	42
8.2 Part Marking Information	45
8.3 Tape & Reel Materials and Design	46
9. Important Notice	49

3. Pin Configuration

3.1 Package Pin-out

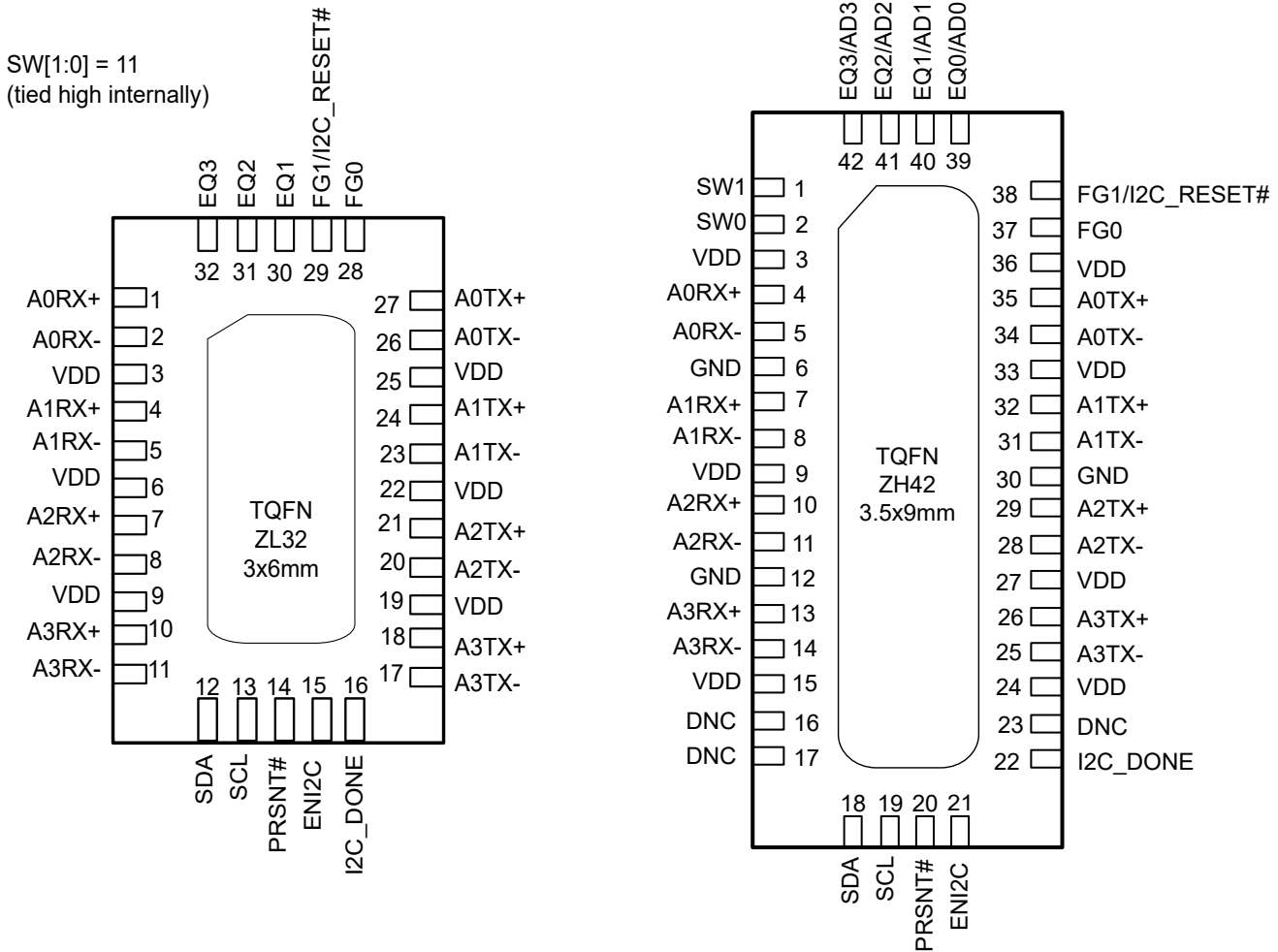

Figure 3-1 32/42-pin package pin-out

Note: In TMDS Data and Clock Differential Pairs of Input and Output, the polarity (+/- or P/N) of each pairs and high-speed data channels A[3:0] can use interchangeably. Output pins of polarity and data channel will always follow the input polarity and data channel assignment changes.

3.2 Pin Description

3.2.1 32-pin package

Pin #	Pin Name	Type	Description
Data Signals			
1 2	A0RX+ A0RX-	I	TMDS differential positive/negative input for Channel A0, with internal 50Ω Pull-Up and ~200kΩ Pull-Up otherwise.
27 26	A0TX+ A0TX-	O	TMDS differential positive/negative outputs for Channel A0, with internal 50Ω Pull-Up and ~2kΩ Pull-Up otherwise.
4 5	A1RX+ A1RX-	I	TMDS differential positive/negative inputs for Channel A1, with internal 50Ω Pull-Up and ~200kΩ Pull-Up otherwise.
24 23	A1TX+ A1TX-	O	TMDS differential positive/negative outputs for Channel A1, with internal 50Ω Pull-Up and ~2kΩ Pull-Up otherwise.
7 8	A2RX+ A2RX-	I	TMDS differential positive/negative inputs for Channel A2, with internal 50Ω Pull-Up and ~200kΩ Pull-Up otherwise.
21 20	A2TX+ A2TX-	O	TMDS differential positive/negative outputs for Channel A2, with internal 50Ω Pull-Up and ~2kΩ Pull-Up otherwise.
10 11	A3RX+ A3RX-	I	TMDS differential positive/negative inputs for Channel A3, with internal 50Ω Pull-Up and ~200kΩ Pull-Up otherwise.
18 17	A3TX+ A3TX-	O	TMDS differential positive/negative outputs for Channel A3, with internal 50Ω Pull-Up and ~2kΩ Pull-Up otherwise.
Control Signals			
12	SDA	I/O	I ² C Serial Data line
13	SCL	I/O	I ² C Serial Clock line In Master mode (ENI2C pin floating), SCL is an output. Otherwise it is an input as a slave mode.
14	PRSNT#	I	Cable Present Detect input. This pin has internal 100KΩ pull-up. The pin is active when both PIN mode (ENI2C = LOW) and I2C mode (ENI2C = HIGH). When High, a cable is not present, and the device is put in lower power mode. When Low, the device is enabled and in normal operation.
15	ENI2C	I	I2C Enable pin. When LOW, each channel is programmed by the external pin voltage. When HIGH, each channel is programmed by the data stored in the I ² C bus. When floating, master mode (Read External EEPROM)
32,31,30	EQ[3:1]	I	EQ Control pin. Inputs with internal 100kΩ pull-up. This pins set the amount of Equalizer Boost in all channels when ENI2C is low.
	AD[3:1]	I	Address bits control pins for I2C programming with internal 100kΩ pull-up.

Pin #	Pin Name	Type	Description
29	FG1/I2C_RE-SET#	I	Shared pin for Gain Control bit-1 and I2C Reset pin. Inputs with internal 100kΩ pull up resistor. (1) Sets the output flat gain level bit-1 on all channels when ENI2C is Low. (2) I2C Reset pin. Active Low to reset the registers to default state.
28	FG0	I	Flat Gain control bit-0 pin. Inputs with internal 100kΩ pull up resistor. Sets the output flat gain level on all channels when ENI2C is low.
16	I2C_DONE	O	I2C Done pin. Valid register load status output for using the daisy chain I2C master. Low = External EEPROM load failed High = External EEPROM load passed
Power Pins			
3,6,9,19,22,25	VDD	PWR	3.3V Power supply pins
Center Pad	GND	GND	Exposed Ground pad.

3.2.2 42-pin package

Pin #	Pin Name	Type	Description
Data Signals			
4 5	A0RX+ A0RX-	I	TMDS differential positive/negative input for Channel A0, with internal 50Ω Pull-Up and ~200kΩ Pull-Up otherwise.
35 34	A0TX+ A0TX-	O	TMDS differential positive/negative outputs for Channel A0, with internal 50Ω Pull-Up and ~2kΩ Pull-Up otherwise.
7 8	A1RX+ A1RX-	I	TMDS differential positive/negative inputs for Channel A1, with internal 50Ω Pull-Up and ~200kΩ Pull-Up otherwise.
32 31	A1TX+ A1TX-	O	TMDS differential positive/negative outputs for Channel A1, with internal 50Ω Pull-Up and ~2kΩ Pull-Up otherwise.
10 11	A2RX+ A2RX-	I	TMDS differential positive/negative inputs for Channel A2, with internal 50Ω Pull-Up and ~200kΩ Pull-Up otherwise.
29 28	A2TX+ A2TX-	O	TMDS differential positive/negative outputs for Channel A2, with internal 50Ω Pull-Up and ~2kΩ Pull-Up otherwise.
13 14	A3RX+ A3RX-	I	TMDS differential positive/negative inputs for Channel A3, with internal 50Ω Pull-Up and ~200kΩ Pull-Up otherwise.
26 25	A3TX+ A3TX-	O	TMDS differential positive/negative outputs for Channel A3, with internal 50Ω Pull-Up and ~2kΩ Pull-Up otherwise.
Control Signals			
16,17,23	DNC		Do Not Connect
19	SCL	I/O	I ² C Serial Clock line In Master mode (ENI2C pin floating), SCL is an output. Otherwise it is an input as a slave mode.
18	SDA	I/O	I ² C Serial Data line
20	PRSNT#	I	Cable Present Detect input. This pin has internal 100KΩ pull-up. The pin is active when both PIN mode (ENI2C = LOW) and I2C mode (ENI2C = HIGH). When High, a cable is not present, and the device is put in lower power mode. When Low, the device is enabled and in normal operation.
21	ENI2C	I	I2C Enable pin. When LOW, each channel is programmed by the external pin voltage. When HIGH, each channel is programmed by the data stored in the I ² C bus. When floating, master mode (Read External EEPROM)

Pin #	Pin Name	Type	Description
39,40,41,42	EQ[3:0]	I	EQ Control pin. Inputs with internal 100kΩ pull-up. This pins set the amount of Equalizer Boost in all channel when ENI2C is LOW.
	AD[3:0]	I	I ² C address bits control pins for programming with internal 100kΩ pull-up.
1,2	SW[1:0]	I	Output Swing control pins. Inputs with internal 100kΩ pull-up. This pin sets the output Voltage Level in all channel when ENI2C is LOW.
37	FG0	I	Gain Control pin bit 0 Inputs with internal 100kΩ pull up resistor. Sets the output flat gain level on all channels when ENI2C is low.
38	FG1/I2C_RE-SET#	I	Shared pin for Flat Gain control bit-1 or I2C Reset pin. Inputs with internal 100kΩ pull up resistor. (1) Sets the output flat gain level bit-1 on all channels when ENI2C is Low. (2) I2C Reset pin. Active Low to reset the registers to default state.
22	I2C_DONE	O	I2C Done pin. Valid register load status output, use for daisy chain master Low = External EEPROM load failed High = External EEPROM load passed
Power Pins			
3, 9, 15, 24, 27, 33, 36	VDD	PWR	3.3V Power Supply pins
6, 12, 30, Center Pad	GND	GND	Exposed Ground pad.

4. Functional

4.1 Functional Block

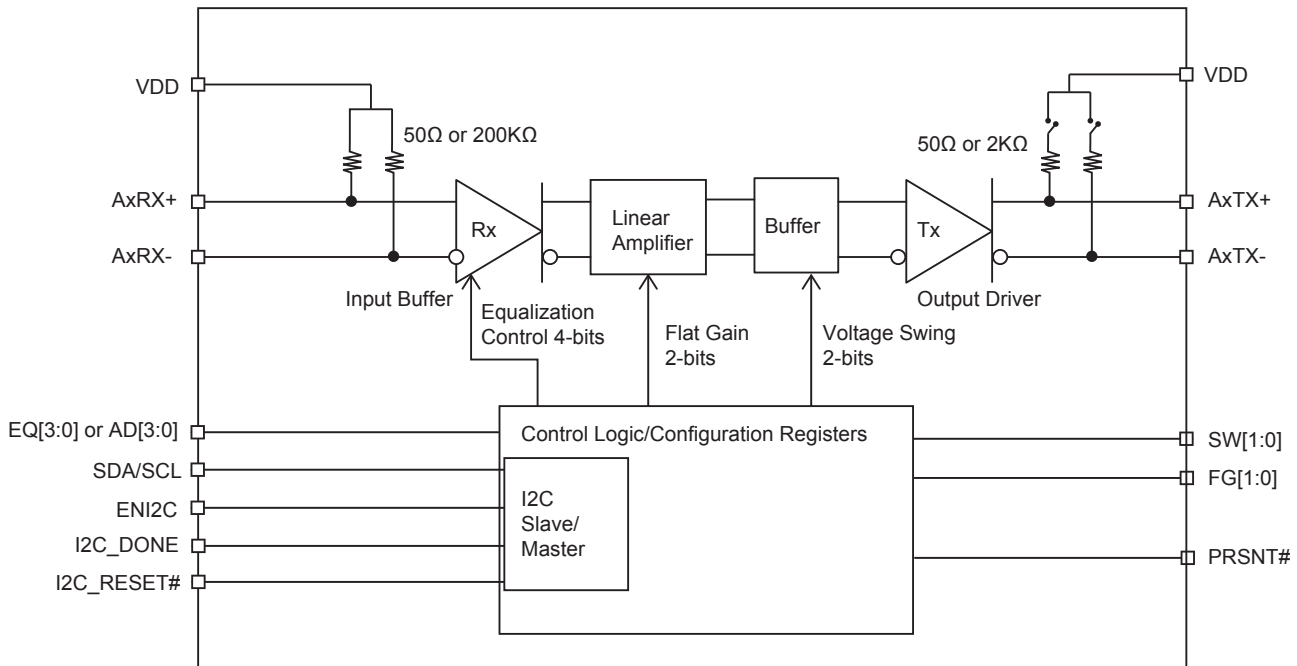

Figure 4-1 Functional Block Diagram

4.2 Function Description

4.2.1 Power-Down/Enable

When PRSNT# is set to "1", device enter to the power-down mode. When Input 200kΩ and Output High Impedance (HIZ) termination resisters set, each individual channels Ax(x=0,1,2,3) can program the I2C register.

4.2.2 Input Equalization Setting

The EQx(x=0,1,2,3) pins are the pin-strap option for each Ax(x=0,1,2,3) channels. It can also be programmable by the I2C mode.

Table 4-1. Equalization Setting for 42-pin

EQ3	EQ2	EQ1	EQ0	6Gbps Input(dB)
0	0	0	0	3.6
0	0	0	1	4.0
0	0	1	0	4.4
0	0	1	1	4.7
0	1	0	0	5.1
0	1	0	1	5.5
0	1	1	0	5.9
0	1	1	1	6.2
1	0	0	0	6.6
1	0	0	1	6.9
1	0	1	0	7.3
1	0	1	1	7.6
1	1	0	0	8.0
1	1	0	1	8.2
1	1	1	0	8.6
1	1	1	1	8.9

Table 4-2. Equalization Setting for 32-pin

EQ3	EQ2	EQ1	6 Gbps Input EQ(dB)	Notes
0	0	0	4.0	(1) EQ0 pin always tied to "1" internally in 32-pin package.
0	0	1	4.7	
0	1	0	5.5	
0	1	1	6.2	
1	0	0	6.9	
1	0	1	7.6	
1	1	0	8.2	
1	1	1	8.9	

4.2.3 Output -1 dB Compression Swing setting

SW_x(x=0,1) affects the linearity of the output when input amplitude changes.

Table 4-3. SW[1:0] Output Swing Setting

SW1	SW0	Voltage Swing mVpp @100MHz	Voltage Swing mVpp @ 6Gbps	Notes
0	0	920	1100	
0	1	1040	1200	
1	0	1280	1300	
1	1	1370	1400	Default Setting. Internally 100kΩ pull-up.

Note

(1) SW[1:0]=11 setting support by I2C programming in 32-pin package

4.2.4 Flat Gain Setting

FG_x(x=0,1) two pins are the selection 2 bits for the DC Flat Gain value.

Table 4-4. Flat Gain FG[1:0] Control

FG1	FG0	Gain (dB)
0	0	-3.5 dB
0	1	-1.5 dB
1	0	+0.5 dB
1	1	+2.5 dB

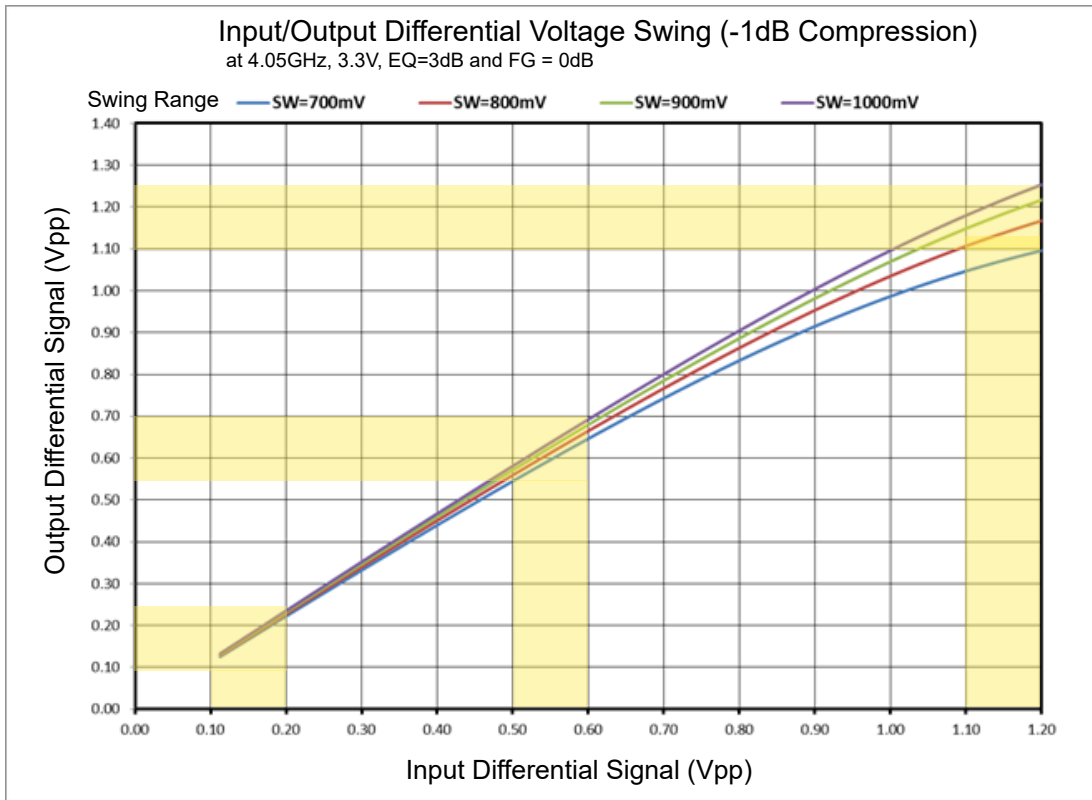

Figure 4-2 Example of Output voltage swing with different SW setting

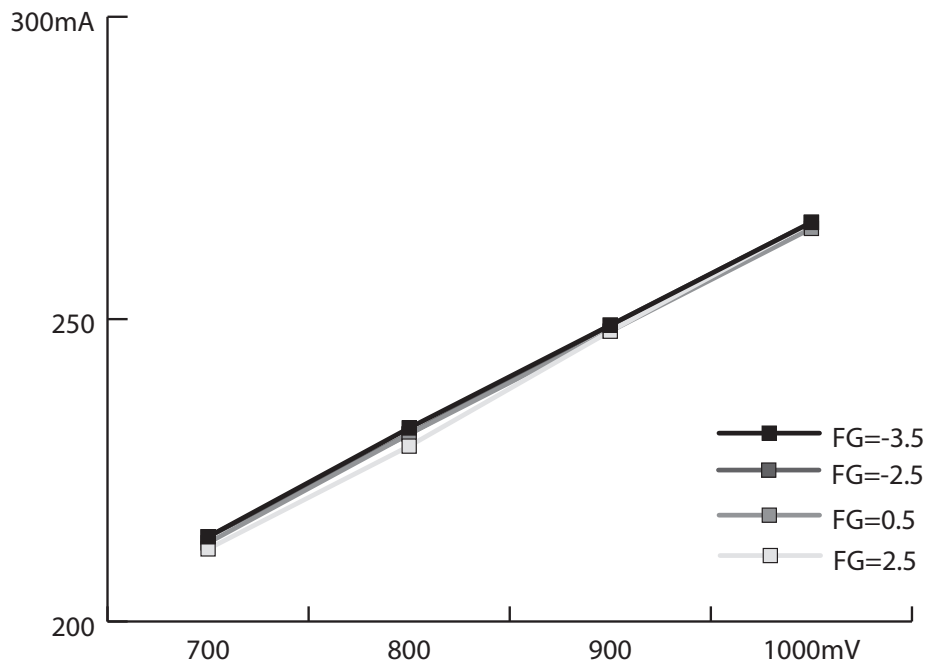

Figure 4-3 Power dissipation mA vs. SW[1:0] setting

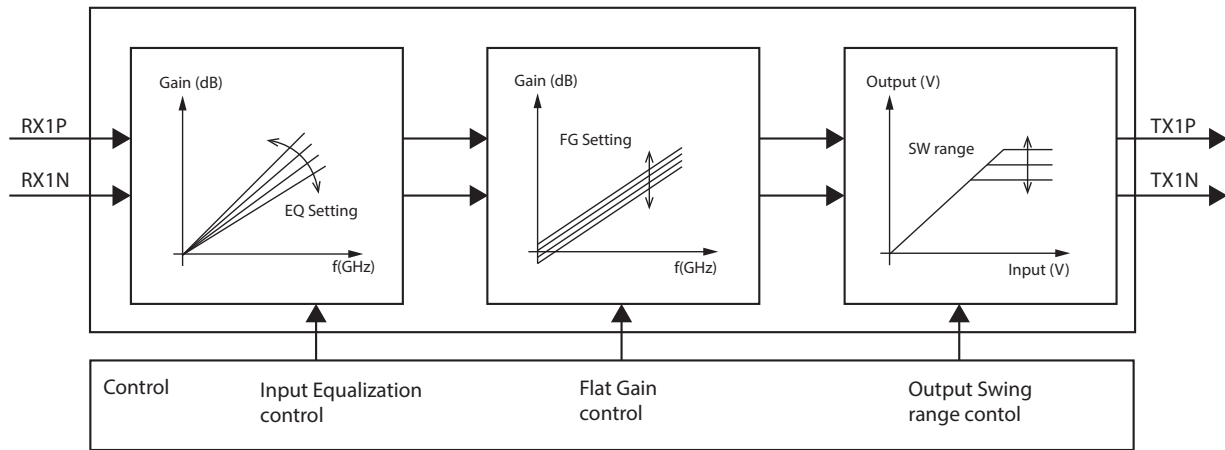

Figure 4-4 Illustration of EQ, Gain and Swing setting

5. I2C Programming

5.1 Programming registers

5.1.1 I2C address

A6	A5	A4	A3	A2	A1	A0	R/W
1	1	1	AD3	AD2	AD1	AD0 ⁽¹⁾	1=R, 0=W

Note:

(1) Address A0 is always "1" tied high for 32-pin package.

5.1.2 Configuration Registers

BYTE 0					
Bit	Type	Power up condition	Description	Control affected	Comment
7:0	R		Reserved		
BYTE 1					
Bit	Type	Power up condition	Description	Control affected	Comment
7:0	R		Reserved		
BYTE 2					
Bit	Type	Power up condition	Description	Control affected	Comment
7	R/W	0		A3 Power down	1 = Power down
6	R/W	0		A2 Power down	
5	R/W	0		A1 Power down	
4	R/W	0		A0 Power down	
3	R/W	0		Reserved	
2	R/W	0		Reserved	
1	R/W	0		Reserved	
0	R/W	0		Reserved	

BYTE 3					
Bit	Type	Power up condition	Description	Control affected	Comment
7	R/W	0	Channel A0 configuration	EQ3	Equalizer
6	R/W	0		EQ2	
5	R/W	0		EQ1	
4	R/W	0		EQ0	
3	R/W	0		FG1	Flat gain
2	R/W	0		FG0	
1	R/W	0		SW1	Swing
0	R/W	0		SW0	

BYTE 4					
Bit	Type	Power up condition	Description	Control affected	Comment
7	R/W	0	Channel A1 configuration	EQ3	Equalizer
6	R/W	0		EQ2	
5	R/W	0		EQ1	
4	R/W	0		EQ0	
3	R/W	0		FG1	Flat gain
2	R/W	0		FG0	
1	R/W	0		SW1	Swing
0	R/W	0		SW0	
BYTE 5					
Bit	Type	Power up condition	Description	Control affected	Comment
7	R/W	0	Channel A2 configuration	EQ3	Equalizer
6	R/W	0		EQ2	
5	R/W	0		EQ1	
4	R/W	0		EQ0	
3	R/W	0		FG1	Flat gain
2	R/W	0		FG0	
1	R/W	0		SW1	Swing
0	R/W	0		SW0	
BYTE 6					
Bit	Type	Power up condition	Description	Control affected	Comment
7	R/W	0	Channel A3 configuration	EQ3	Equalizer
6	R/W	0		EQ2	
5	R/W	0		EQ1	
4	R/W	0		EQ0	
3	R/W	0		FG1	Flat gain
2	R/W	0		FG0	
1	R/W	0		SW1	Swing
0	R/W	0		SW0	
BYTE 7					
Bit	Type	Power up condition	Description	Control affected	Comment
7:0	R/W		Reserved		
BYTE 8-15					
Bit	Type	Power up condition	Description	Control affected	Comment
power up condition : "0"					

5.2 I2C operation

The integrated I2C interface operates as a slave device mode. Standard I2C mode (100 Kbps) is supported with 7-bit addressing and data byte format 8-bit.

The device supports Read/Write. The bytes must be accessed in sequential order from the lowest to the highest byte with the ability to stop after any complete byte has been transferred. Address bits A3 to A0 are programmable to support multiple chips environment. The Data is loaded until a Stop sequence is issued.

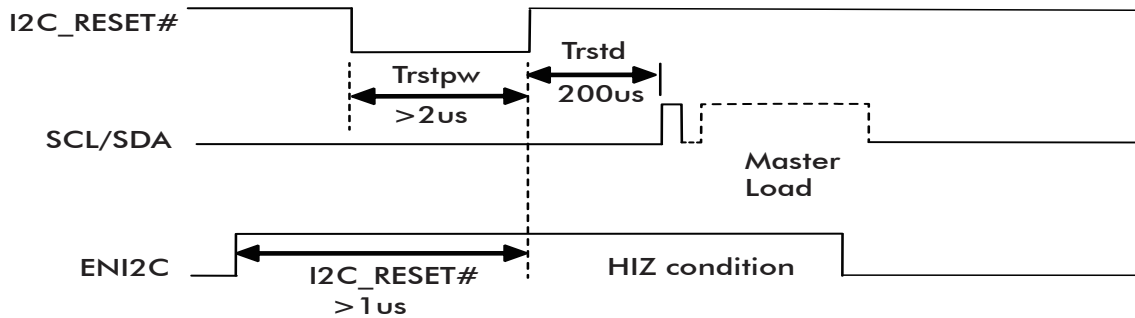

Figure 5-1 I2C Reset, Enable and SCL/SDA Timing Diagram

Transferring Data

Every byte put on the SDA line must be 8-bit long. Each byte has to be followed by an acknowledge bit. Data is transferred with the most significant bit (MSB) first (see the I2C Data Transfer diagram). It will never hold the clock line SCL LOW to force the master into a wait state.

Acknowledge

Data transfer with acknowledge is required from the master. When the master releases the SDA line (HIGH) during the acknowledge clock pulse, it will pull down the SDA line during the acknowledge clock pulse so that it remains stable LOW during the HIGH period of this clock pulse as indicated in the I2C Data Transfer diagram. It will generate an acknowledge after each byte has been received.

Data Transfer

A data transfer cycle begins with the master issuing a start bit. After recognizing a start bit, it will watch the next byte of information for a match with its address setting. When a match is found it will respond with a read or write of data on the following clocks. Each byte must be followed by an acknowledge bit, except for the last byte of a read cycle which ends with a stop bit. Data is transferred with the most significant bit (MSB) first.

Start & Stop Conditions

A HIGH to LOW transition on the SDA line while SCL is HIGH indicates a START condition. A LOW to HIGH transition on the SDA line while SCL is HIGH defines a STOP condition.

Table 5-1. I2C Address Setting with 4-bits AD[3:0]

I2C address: AD3, AD2, AD1, AD0	Data starting location
0000	00H
0001	10H
0010	20H
0011	30H
0100	40H
0101	50H
0110	60H
0111	70H
1000	80H
1001	90H
1010	A0H
1011	B0H
1100	C0H
1101	D0H
1110	E0H
1111	F0H

Read Sequence

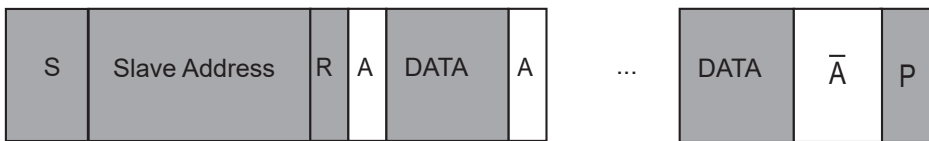

Write Sequence

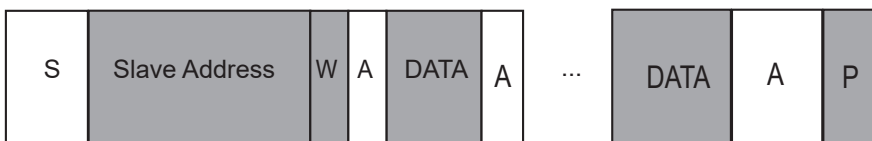

From master to slave A= acknowledge \bar{A} = not acknowledge
 From slave to master S= start condition P= stop condition

Figure 5-2 I2C Read / Write Timing Sequence

6. Electrical Specification

6.1 Absolute Maximum ratings

Supply Voltage to Ground Potential.....	-0.5 V to +4.6 V
DC SIG Voltage.....	-0.5 V to $V_{DD} + 0.5$ V
Output Current.....	-25 mA to +25 mA
Power Dissipation Continuous.....	2.1 W
ESD, HBM.....	-2 kV to +2 kV
Storage Temperature.....	-65 °C to +150 °C

Note
Stresses greater than those listed under MAXIMUM RATINGS may cause permanent damage to the device. This is a stress rating only and functional operation of the device at these or any other conditions above those indicated in the operational sections of this specification is not implied. Exposure to absolute maximum rating conditions for extended periods may affect reliability.

6.2 Recommended operating conditions

Parameter	Min.	Typ.	Max	Units
Power supply voltage (VDD to GND) ⁽¹⁾	3.0	3.3	3.6	V
I2C (SDA, SCL)			3.6	V
Supply Noise Tolerance up to 25 MHz ⁽²⁾			100	mVp-p
Ambient Temperature	-40	25	85	°C

Note
(1) Typical parameters are measured at $V_{CC} = 3.3 \pm 0.3V$, $T_A = 25^\circ C$. They are for the reference purposes, and are not production-tested
(2) Allow supply noise (mVp-p sine wave) under typical condition

6.3 Electrical characteristics

Over recommend operating supply and temperature range unless otherwise specified.

6.3.1 LVCMOS DC specifications

Symbol	Parameter	Conditions	Min.	Typ.	Max	Unit
V_{IH}	DC input logic high		$V_{DD}/2 + 0.7$		$V_{DD} + 0.3$	V
V_{IL}	DC input logic low		-0.3		$V_{DD}/2 - 0.7$	V
V_{OH}	At $I_{OH} = -200\mu A$		$V_{DD} + 0.2$			V
V_{OL}	At $I_{OL} = -200\mu A$				0.2	V
V_{hys}	Hysteresis of Schmitt trigger input		0.8			V

6.3.2 Power Dissipation

Symbol	Parameter	Conditions	Min.	Typ.	Max.	Unit
I_{DD}	Supply current	PRSENT#=0, SW=1000mVdiff, FG=2.5		256	290	mA
		PRSENT#=0, SW=900mVdiff, FG=2.5		240		mA
		PRSENT#=0, SW=800mVdiff, FG=2.5		233		mA
I_{DDQ}	Quiescent supply current	PRSENT#=1, TMDS Output Disable		2.0	4.2	mA

6.3.3 Package power ratings

Package	Theta Ja(still air) (°C/W)	Theta Jc (°C/W)	Max. Power Dissipation Rating Ta ≤ 70°
32-pin TQFN (ZL32)	37.05	11.3	1.48W
42-pin TQFN (ZH42)	33.69	15.17	1.63W

6.3.4 Switching I/O characteristics

Symbol	Parameter	Conditions	Min.	Typ.	Max.	Unit
V _{RX-DIF-Fp-p}	Peak to peak differential input voltage			200		mV
T _R	Rise Time	Input signal with 30ps rise time, 20% to 80%		31		ps
T _F	Falling Time	Input signal with 30ps rise time, 20% to 80%		31		ps
T _{PLH}	Low-to-High Propagation Delay			65		ps
T _{PHL}	High-to-Low Propagation Delay			65		ps
T _{SK_IN-TRA_IN}	Input Intra-pair Differential Skew tolerance				0.15	UI
T _{SK_IN-TRA_OUT}	Output Intra-pair Differential Skew			5	10	ps
T _{SK_IN-TER_OUT}	Output Inter-pair Differential Skew			8		ps
R _J	Add-in Random Jitter	at 6Gbps		0.57		RMS ps
D _J	Add-in Deterministic Jitter	at 6Gbps		6.57		ps
T _{SX}	Select to Switch Output				10	ns
S ₂₂	Output return loss	10 MHz to 6 Gbps differential		13		dB
		2 Gbps to 6 Gbps common mode		8		
R _{IN}	DC single-ended input impedance			50		Ω
	DC Differential Input Impedance			100		
R _{OUT}	DC single-ended output impedance			50		Ω
	DC Differential output Impedance			100		
Z _{RX-HIZ}	DC input CM input impedance during reset or power down			200		kΩ
V _{RX-DIFF-PP}	Differential Input Peak-to-peak Voltage	Operational			1.4	V _{ppd}

Symbol	Parameter	Conditions	Min.	Typ.	Max.	Unit
V _{CM-NOISE}	Input source common-mode noise	DC – 200MHz			150	mV _{pp}
T _{TX-IDLE-SET-TO-IDLE}	Max time to electrical idle after sending an EIOS			4	8	ns
T _{TX-IDLE-TO-DIFF-DATA}	Max time to valid differential signal after leaving electrical idle			4	8	ns
T _{PD}	Latency	From input to output		0.5		ns
G _p	Peaking gain (Compensation at 6Gbps, relative to 100MHz, 100mV _{p-p} sine wave input)	EQ<3:0> = 1111		8.9		dB
		EQ<3:0> = 1000		6.6		
		EQ<3:0> = 0000		3.6		
		Variation around typical	-3		+3	dB
G _F	Flat gain (100MHz, EQ<3:0> = 1000, SW<1:0> = 10)	FG<1:0> = 11		-3.5		dB
		FG<1:0> = 10		-1.5		
		FG<1:0> = 01		0.5		
		FG<1:0> = 00		2.5		
		Variation around typical	-3		+3	dB
V _{1dB_100M}	-1dB compression point of output swing (at 100MHz)	SW<1:0> = 11 SW<1:0> = 10 SW<1:0> = 01 SW<1:0> = 00		1400 1300 1200 1100		mV _{ppd}
V _{1dB_6G}	-1dB compression point of output swing (at 6 Gbps)	SW<1:0> = 11 SW<1:0> = 10 SW<1:0> = 01 SW<1:0> = 00		1300 1200 1100 1000		mV _{ppd}
V _{Coup}	Channel isolation	100MHz to 6 Gbps		40		dB
V _{noise_in-put}	Input-referred noise ⁽²⁾	100MHz to 6 Gbps, FG<1:0> = 11, EQ<3:0> = 0000		0.5		mV _{RMS}
		100MHz to 6 Gbps, FG<1:0> = 11, EQ<3:0> = 1010		0.4		
V _{noise_output}	Output-referred noise ⁽²⁾	100MHz to 6 Gbps, FG<1:0> = 11, EQ<3:0> = 0000		0.7		mV _{RMS}
		100MHz to 6 Gbps, FG<1:0> = 11, EQ<3:0> = 1010		0.8	1.6	

Note

(1) Measured using a vector-network analyzer (VNA) with -15dBm power level applied to the adjacent input. The VNA detects the signal at the output of the victim channel. All other inputs and outputs are terminated with 50Ω.

(2) Guaranteed by design.

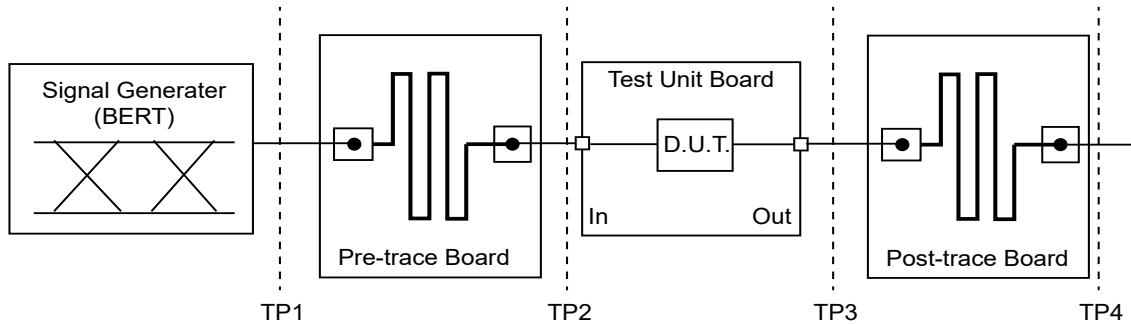
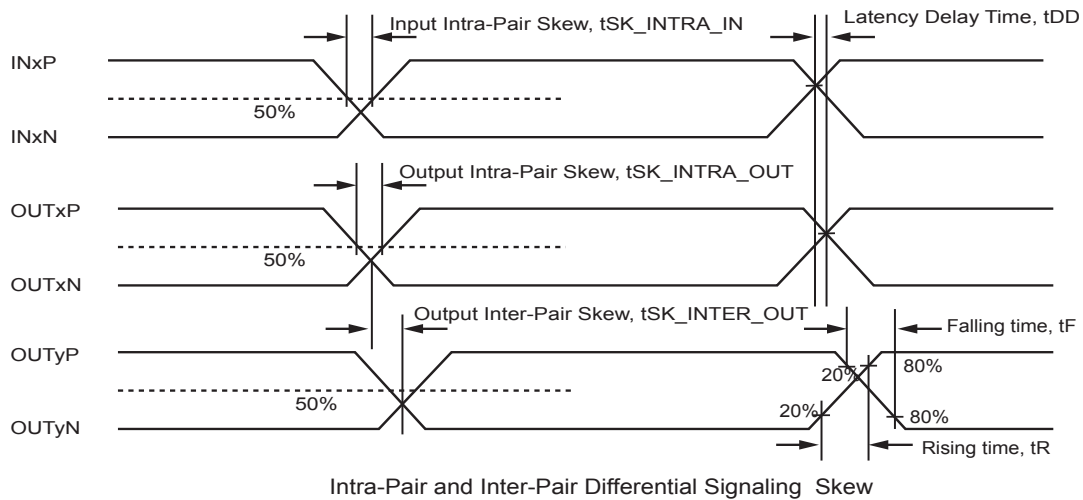

Figure 6-1 Electrical parameter test setup



Intra-Pair and Inter-Pair Differential Signaling Skew

Figure 6-2 Intra and Inter-pair Differential Skew definition

Common Mode Voltage
 $V_{CM} = (|VD+ + VD-| / 2)$
 $V_{CMP} = (\max |VD+ + VD-| / 2)$

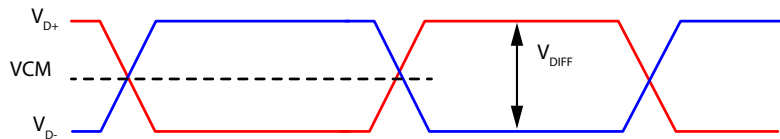

$V_{D+} - V_{D-}$

Symmetric Differential Swing
 $V_{DIFFP-P} = (2 * \max |V_{D+} - V_{D-}|)$

Asymmetric Differential Swing
 $V_{DIFFD-D} = (\max |V_{D+} - V_{D-}| \{V_{D+} > V_{D-}\})$

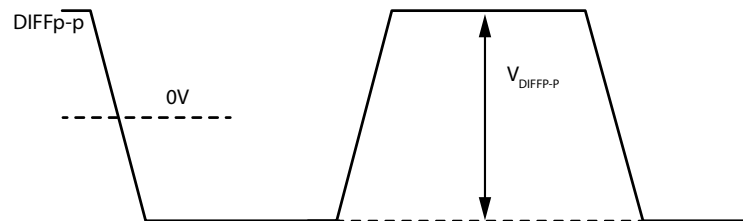

Figure 6-3 Definition of Peak-to-peak Differential voltage

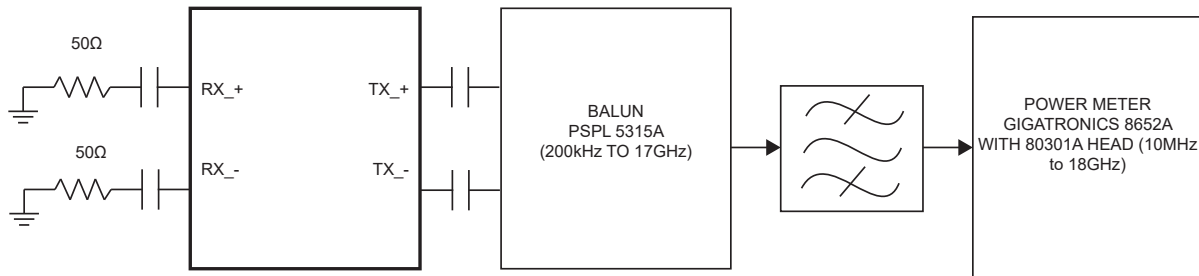

Figure 6-4 Noise test configuration

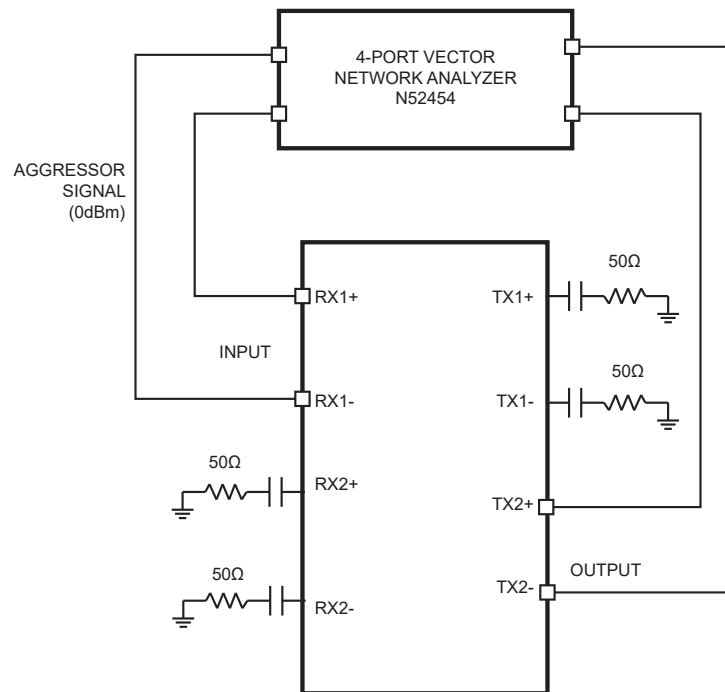

Figure 6-5 Channel-isolation test configuration

Figure 6-6

6.4 I2C Interface Bus

Symbol	Parameter	Conditions	Min.	Typ.	Max	Units
VDD	Nominal Bus Voltage		3.0		3.6	V
Freq	Bus Operation Frequency				400	kHz
V _{IH}	DC input logic high		$V_{DD}/2 + 0.7$		$V_{DD} + 0.3$	V
V _{IL}	DC input logic low		-0.3		$V_{DD}/2 - 0.7$	V
V _{OL}	DC output logic low	I _{OL} = 3mA			0.4	V
I _{pullup}	Current Through Pull-Up Resistor or Current Source	High Power specification	3.0		3.6	mA
I _{leak-bus}	Input leakage per bus segment		-200		200	uA
I _{leak-pin}	Input leakage per device pin			-15		uA
CI	Capacitance for SDA/SCL				10	pF
t _{BUF}	Bus Free Time Between Stop and Start condition		1.3			us
t _{HD:STA}	Hold time after (Repeated) Start condition. After this period, the first clock is generated.	At pull-up, Max	0.6			us
TSU:STA	Repeated start condition setup time		0.6			us
TSU:STO	Stop condition setup time		0.6			us
THD:DAT	Data hold time		0			ns
TSU:DAT	Data setup time		100			ns
t _{LOW}	Clock low period		1.3			us
t _{HIGH}	Clock high period		0.6		50	us
t _F	Clock/Data fall time				300	ns
t _R	Clock/Data rise time				300	ns
t _{POR}	Time in which a device must be operation after power-on reset				500	ms

Note:

- (1) Recommended maximum capacitance load per bus segment is 400pF.
- (2) Compliant to I2C physical layer specification.
- (3) Ensured by Design. Parameter not tested in production.

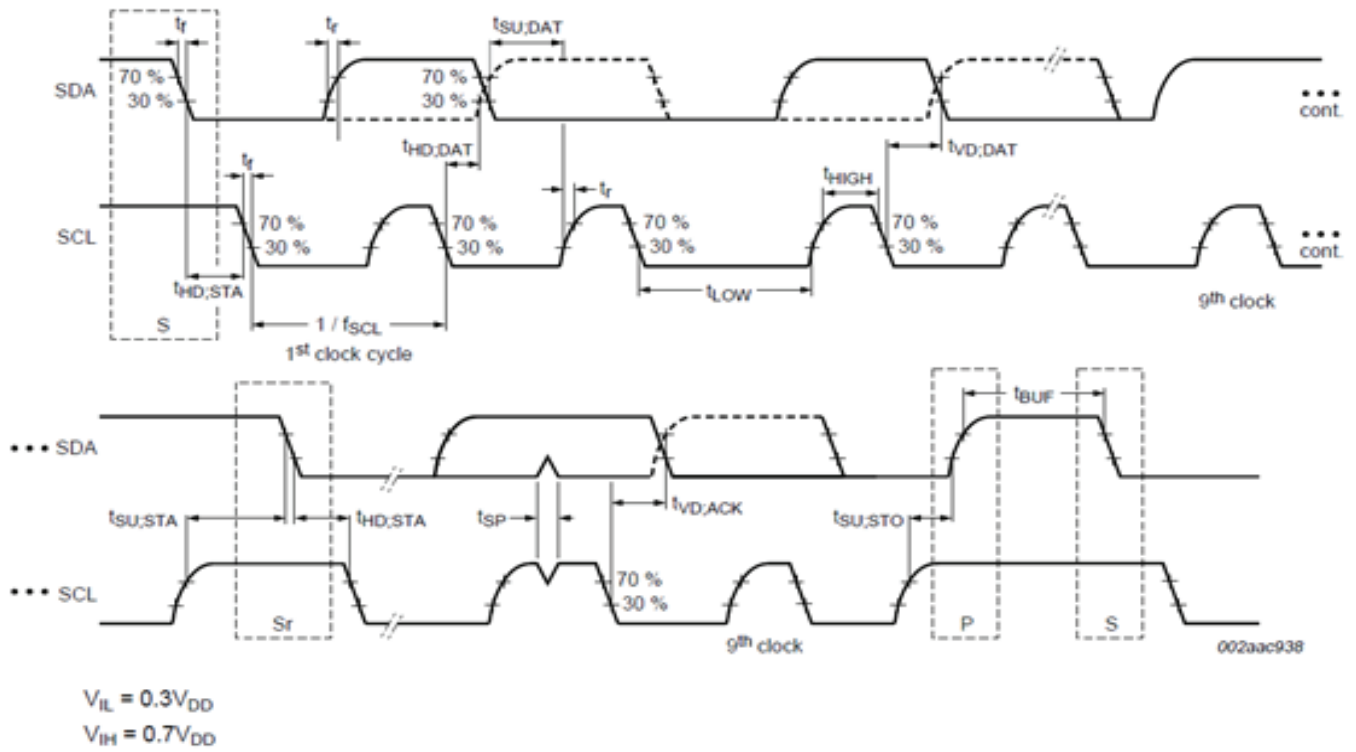
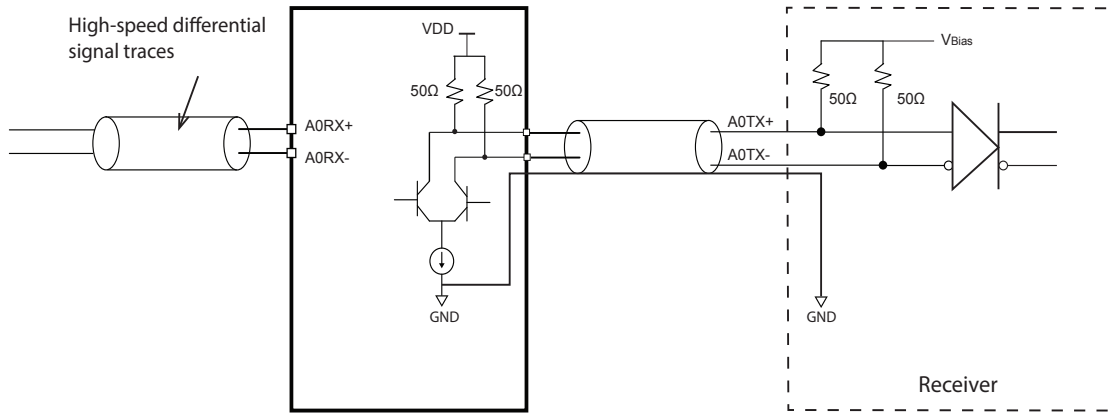

Figure 6-7 I2C Timing definition

7. Applications

7.1 DC/AC-coupled Application



DC-Coupled Differential Signaling Application Circuits

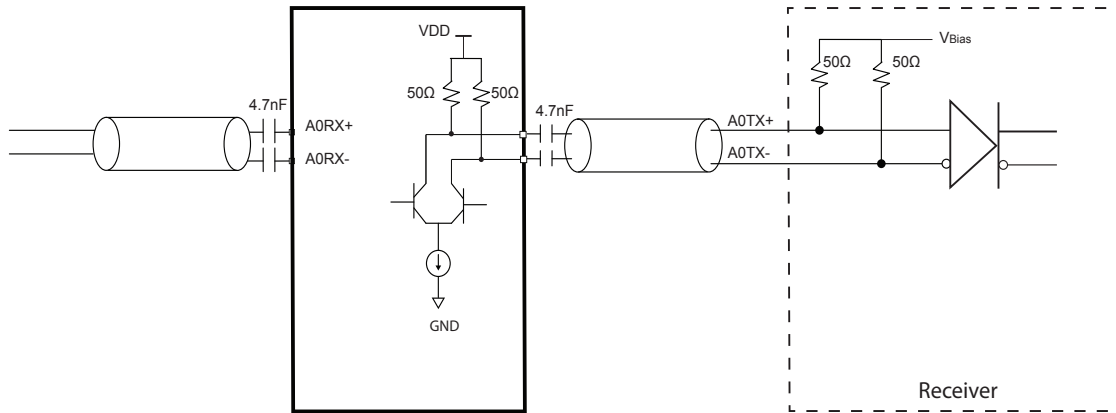

AC-Coupled Differential Signaling Application Circuits

Figure 7-1 DC/AC-coupled application diagram

7.2 Sink-side Redriver Application

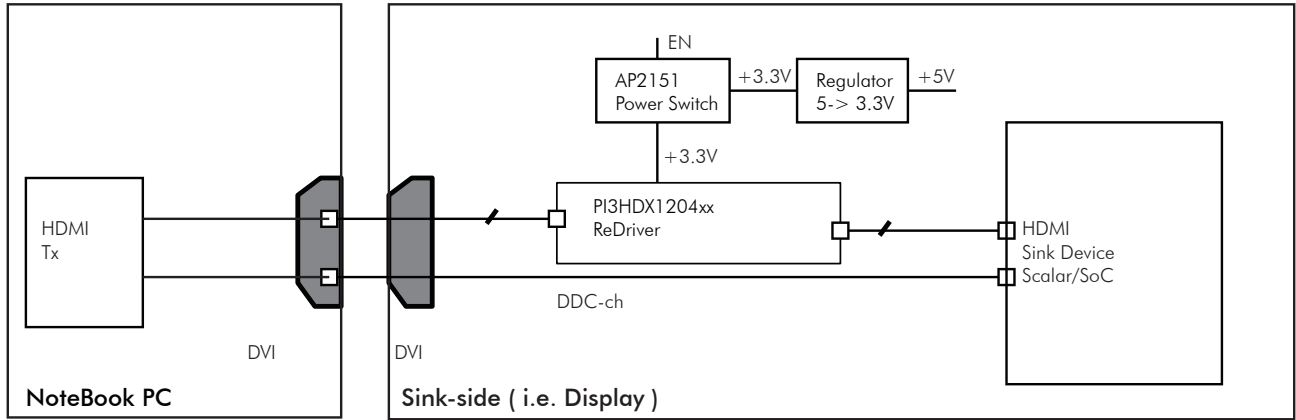

Figure 7-2 HDMI Sink-side application

7.3 Channels/Polarity Swap

Linear Redriver does not have built-in internal channel/polarity switch. Transmitter can send swapped polarity signal to the Redriver.

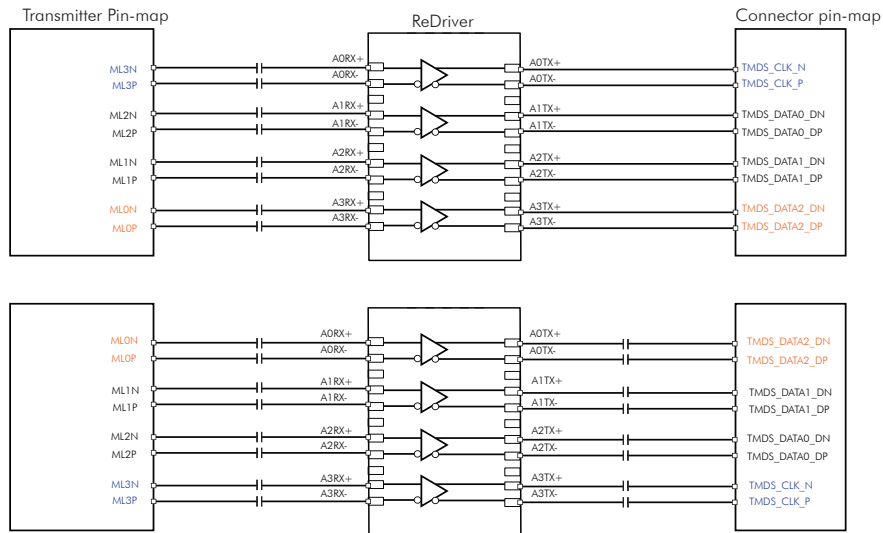

Figure 7-3 Polarity Swap Connection

7.4 Output Eye Diagram

7.4.1 Trace Card Loss Informations

Frequency	3 GHz	6GHz	Units
6 inch Input Trace	-1.43	-4	dB
12 inch Input Trace	-6.1	-11	dB
18 inch Input Trace	-8.34	-15	dB
30 inch Input Trace	-10.14	-18	dB
36 inch Input Trace	-12.13	-22	dB
48 inch Input Trace	-16.42	-29	dB

Table 7-1. Characterization Trace Card dB Loss Information

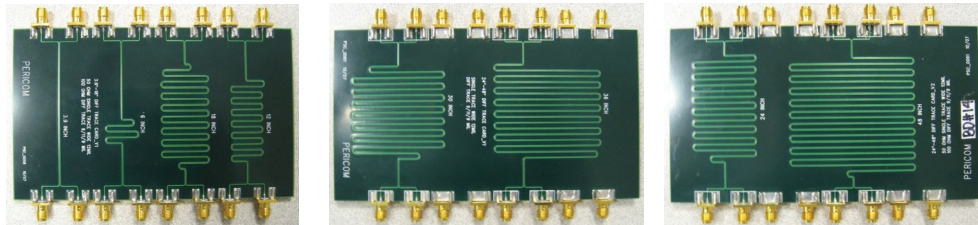

Figure 7-4 Trace board photo

7.4.2 Output Eye Diagram measurement

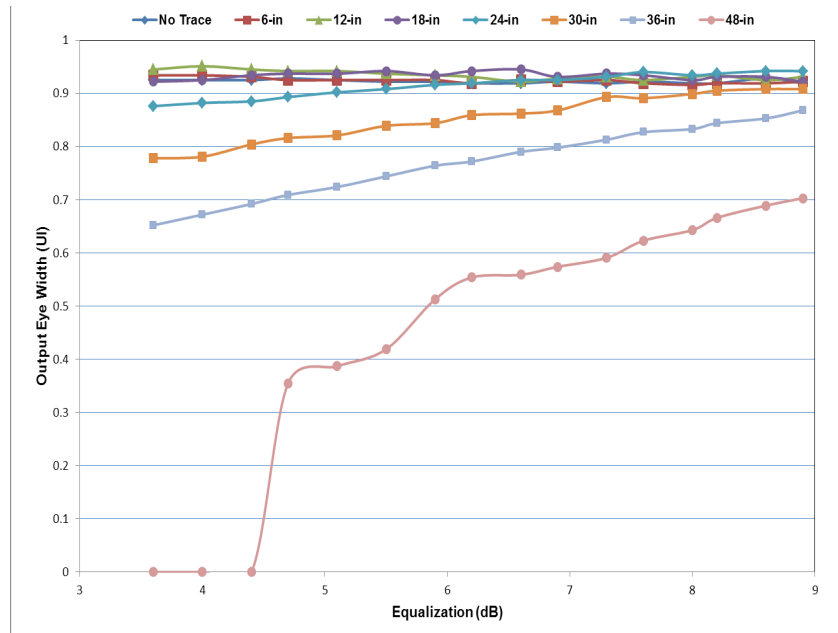

Figure 7-5 Eye Width vs. EQ plots at 6 Gbps, PRBS2²³-1, FG=11 (Gain +2.5dB)
Eye Width vs EQ, FG =1000mV, Gain=+2.5dB (Input Swing=800mVd)

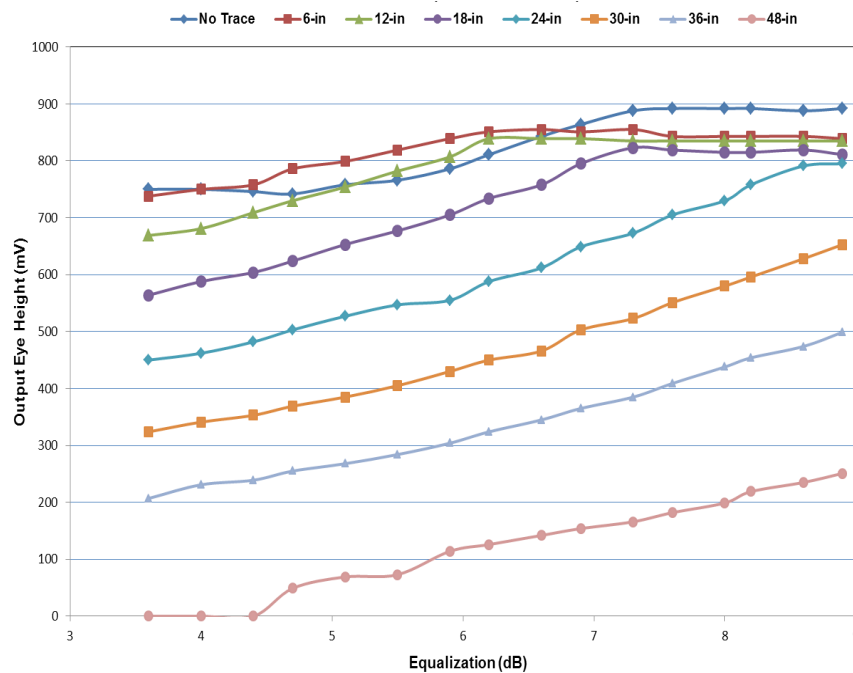

Figure 7-6 Eye Width vs. EQ plots at 6 Gbps, PRBS2²³-1, FG=10 (Gain +0.5dB)
Eye Height vs EQ, FG=1000mV, Gain=+2.5dB (input swing=800mVd)

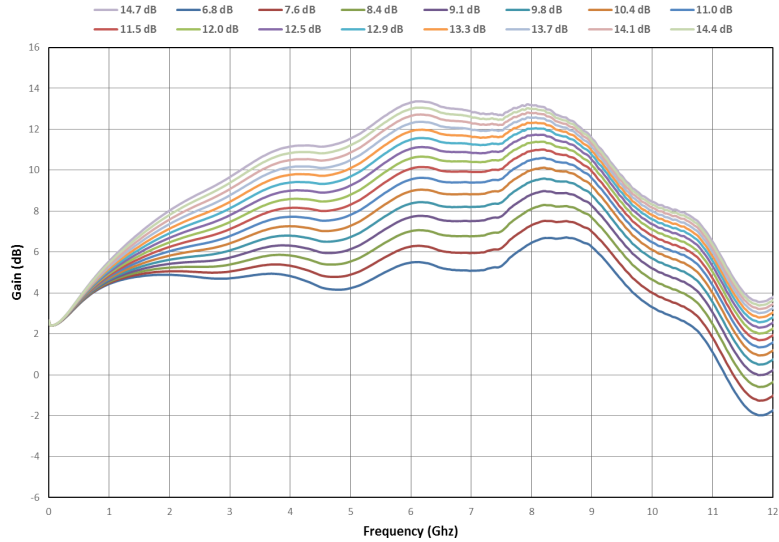

Figure 7-7 Frequency response vs EQ
with FG=11(+2.5dB), Output Swing=1000mV, Vdd=3.0V, 25C, Input Power=-15dBm, No Input Trace

7.4.3 Output Eye diagram

Condition: PRBS 2²³-1 pattern, Input Swing=800mVdiff, Output Swing= 1000mVdiff

Table 7-2. Output Eye diagram by EQ changes at FG 0.5dB

No Trace, FG=0.5dB	6-in trace, FG=0.5dB	12-in trace, FG=0.5dB	18-in trace, FG=0.5dB
 EQ=3dB	 EQ=3dB	 EQ=5dB	 EQ=6dB
 EQ=10dB	 EQ=13.3dB	 EQ=14.5dB	 EQ=15dB

Table 7-3. Output Eye Diagram by EQ changes at FG 2.5dB

No Trace, FG=2.5dB	6-in trace, FG=2.5dB	12-in trace, FG=2.5dB	18-in trace, FG=2.5dB
 EQ=3dB	 EQ=3dB	 EQ=5dB	 EQ=8dB
24-in trace, FG=2.5dB	30-in trace, FG=2.5dB	36-in trace, FG=2.5dB	48-in trace, FG=2.5dB
 EQ=13dB	 EQ=15dB	 EQ=15dB	 EQ=15dB

7.5 Layout Guidelines

As transmission data rate increases rapidly, any flaws and/or mis-matches on PCB layout are amplified in terms of signal integrity. Layout guideline for high-speed transmission is highlighted in this application note.

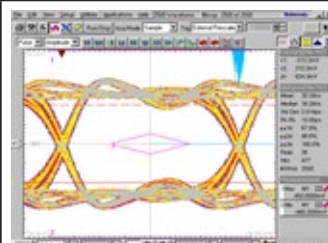
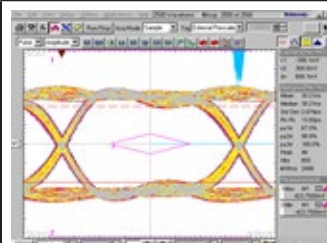
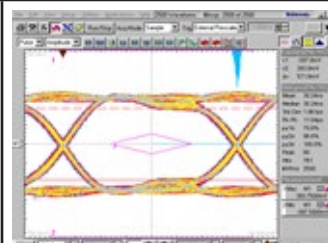
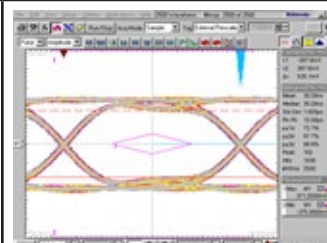
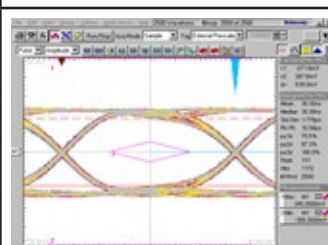
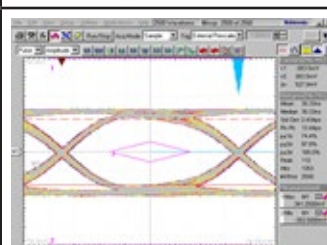
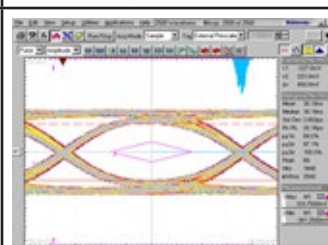
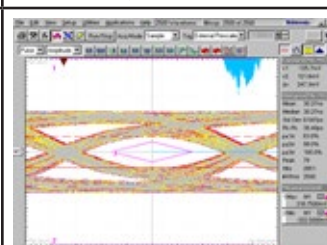
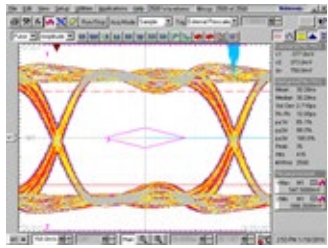
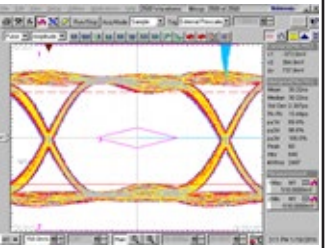
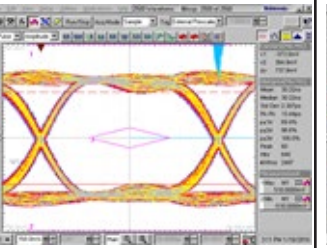
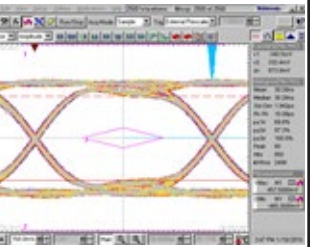
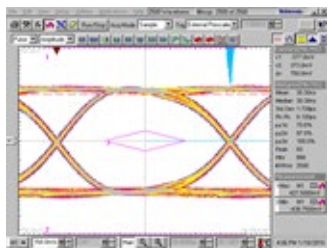
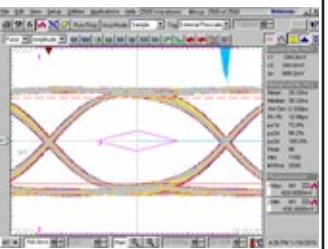
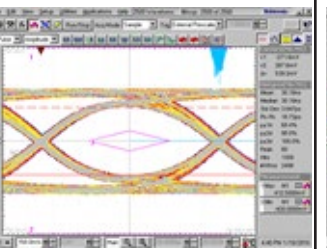
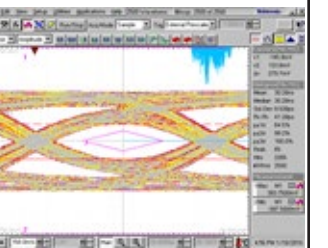
7.5.1 Power and Ground

To provide a clean power supply for high-speed device, few recommendations are listed below:

- Power (VDD) and ground (GND) pins should be connected to corresponding power planes of the printed circuit board directly without passing through any resistor.
- The thickness of the PCB dielectric layer should be minimized such that the VDD and GND planes create low inductance paths.
- One low-ESR 0.1uF decoupling capacitor should be mounted at each VDD pin or should supply bypassing for at most two VDD pins. Capacitors of smaller body size, i.e. 0402 package, is more preferable as the insertion loss is lower. The capacitor should be placed next to the VDD pin.
- One capacitor with capacitance in the range of 4.7uF to 10uF should be incorporated in the power supply decoupling design as well. It can be either tantalum or an ultra-low ESR ceramic.
- A ferrite bead for isolating the power supply for Pericom high-speed device from the power supplies for other parts on the printed circuit board should be implemented.
- Several thermal ground vias must be required on the thermal pad. 25-mil or less pad size and 14-mil or less finished hole are recommended.

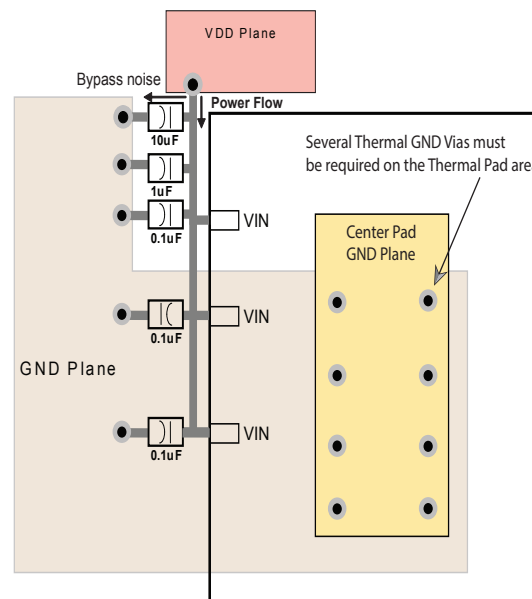

Figure 7-8 Decoupling Capacitor Placement Diagram

7.5.2 High-speed signal Routing

Well-designed layout is essential to prevent signal reflection:

- For 90Ω differential impedance, width-spacing-width micro-strip of 6-7-6 mils is recommended; for 100Ω differential impedance, width-spacing-width micro-strip of 5-7-5 mils is recommended.
- Differential impedance tolerance is targeted at ±15%.

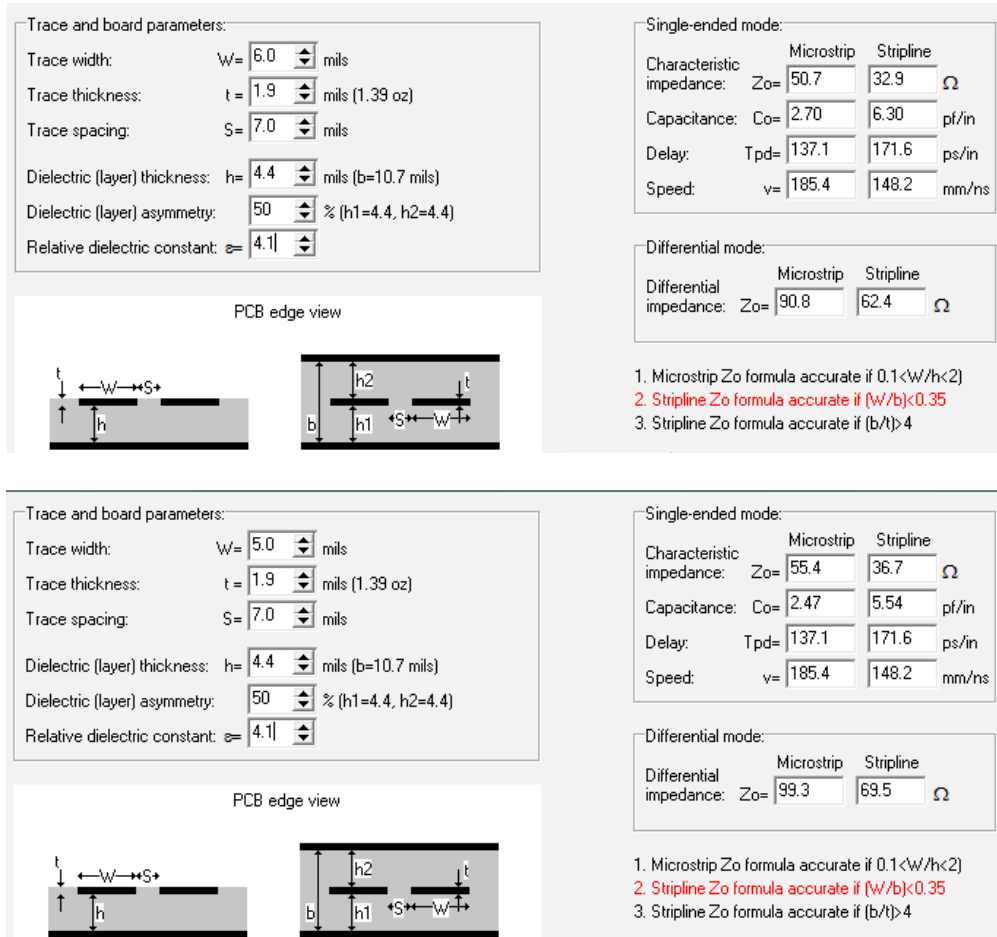

Figure 7-9 Trace Width and Clearance of Micro-strip and Strip-line

- For micro-strip, using 1/2oz Cu is fine. For strip-line in 6+ PCB layers, 1oz Cu is more preferable.

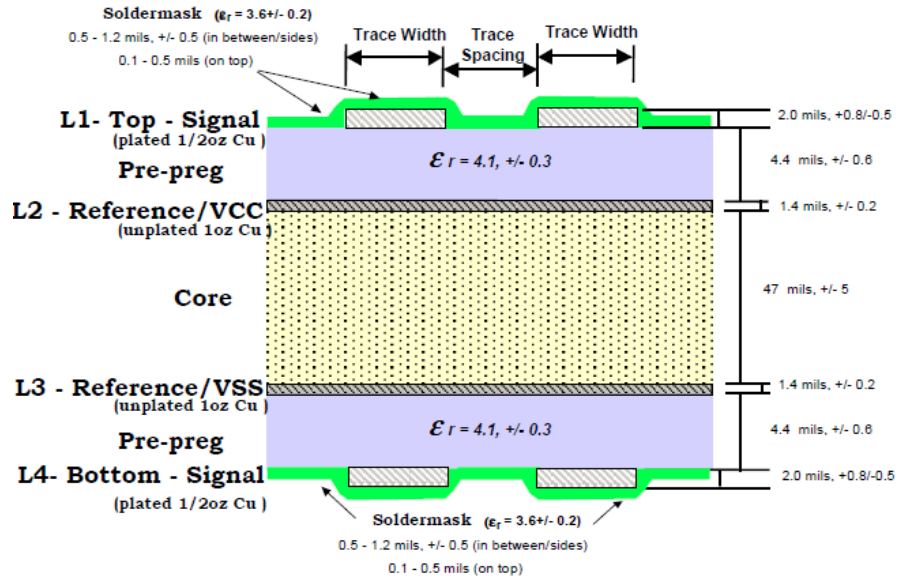

Figure 7-10 4-Layer PCB Stack-up Example

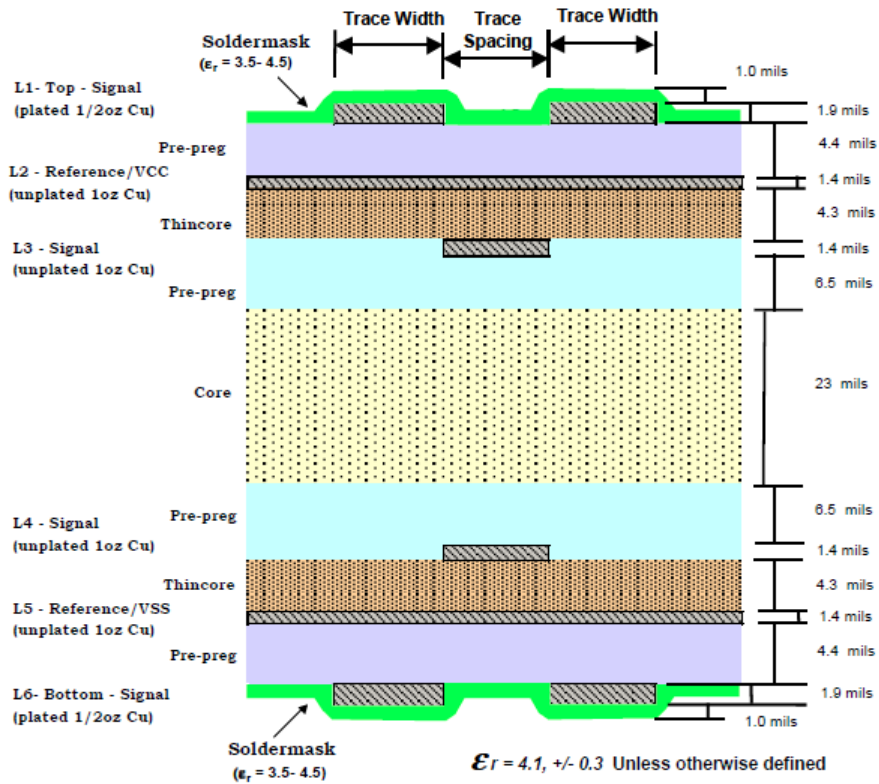

Figure 7-11 6-Layer PCB Stack-up Example

- Ground referencing is highly recommended. If unavoidable, stitching capacitors of 0.1uF should be placed when reference plane is changed.

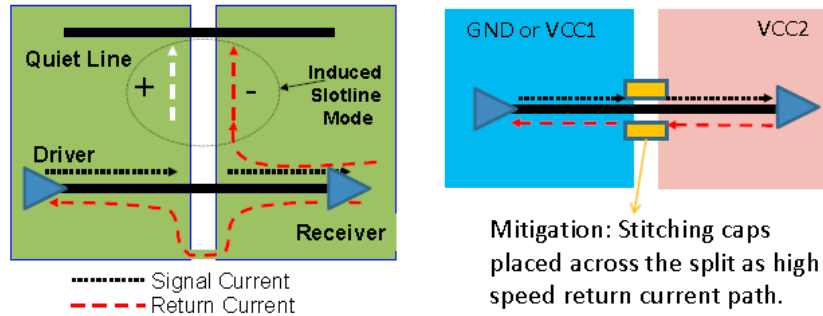

Figure 7-12 Stitching Capacitor Placement

- To keep the reference unchanged, stitching vias must be used when changing layers.
- Differential pair should maintain symmetrical routing whenever possible. The intra-pair skew of micro-strip should be less than 5 mils.
- To keep the reference unchanged, stitching vias must be used when changing layers.
- Differential pair should maintain symmetrical routing whenever possible. The intra-pair skew of micro-strip should be less than 5 mils.

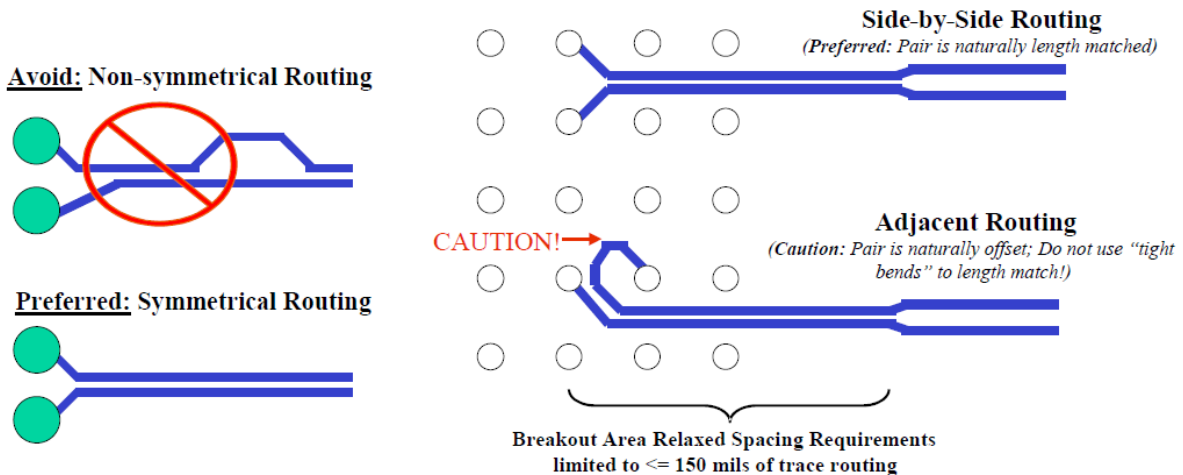

Figure 7-13 Layout Guidance of Matched Differential Pair

- For minimal crosstalk, inter-pair spacing between two differential micro-strip pairs should be at least 20 mils or 4 times the dielectric thickness of the PCB.
- Wider trace width of each differential pair is recommended in order to minimize the loss, especially for long routing. More consistent PCB impedance can be achieved by a PCB vendor if trace is wider.
- Differential signals should be routed away from noise sources and other switching signals on the printed circuit board.

- To minimize signal loss and jitter, tight bend is not recommended. All angles α should be at least 135 degrees. The inner air gap A should be at least 4 times the dielectric thickness of the PCB.

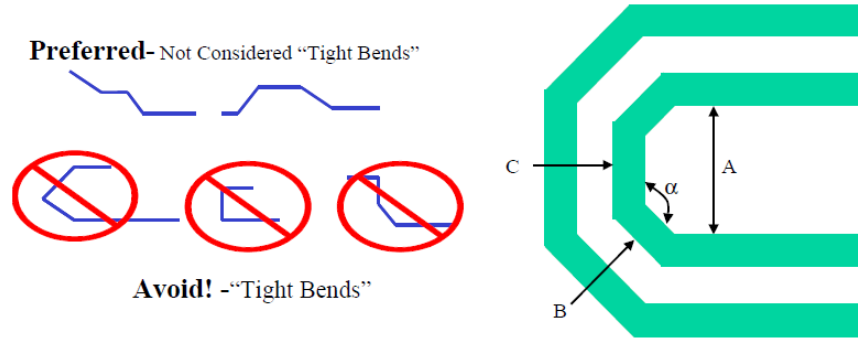

Figure 7-14 Layout Guidance of Bends

- Stub creation should be avoided when placing shunt components on a differential pair.

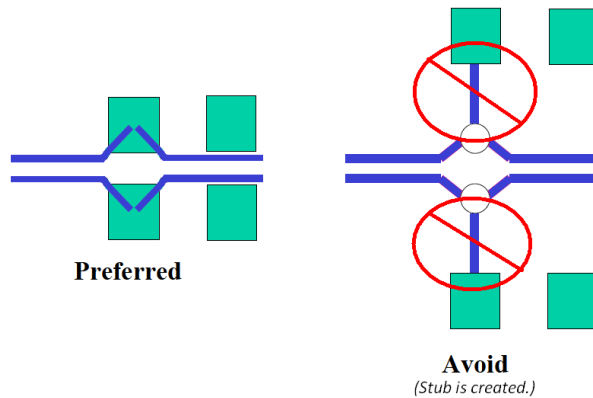

Figure 7-15 Layout Guidance of Shunt Component

- Placement of series components on a differential pair should be symmetrical.

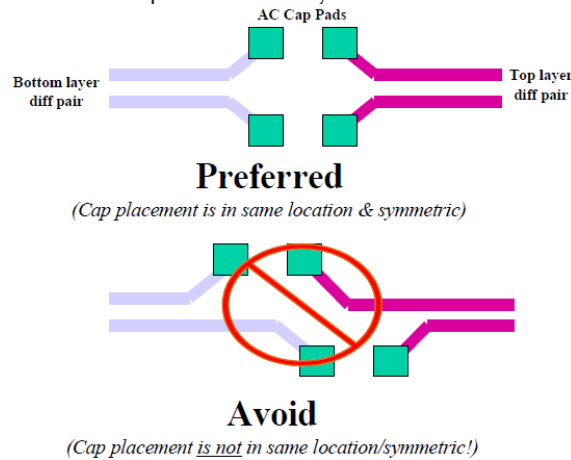

Figure 7-16 Layout Guidance of Series Component

- Stitching vias or test points must be used sparingly and placed symmetrically on a differential pair.

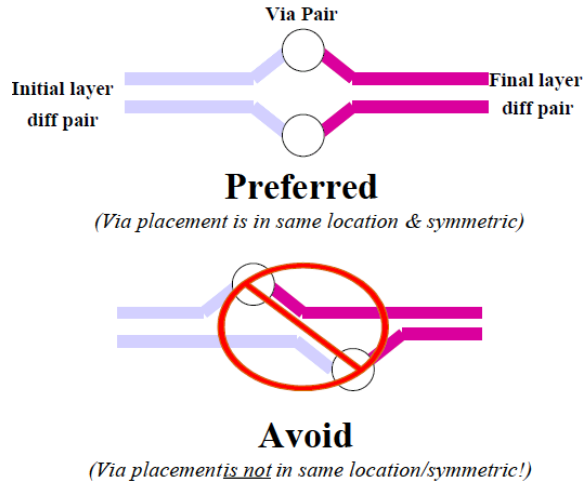

Figure 7-17 Layout Guidance of Stitching Via

7.6 HDMI 2.0 Compliance Test

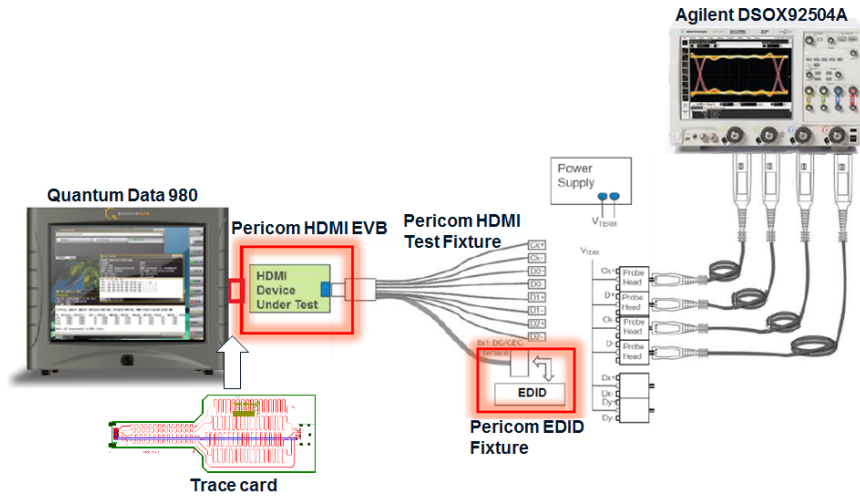

Figure 7-18 HDMI 2.0 CTS test setup*

Note:

Table 7-4. Application Trace Card Information for CTS test

HDMI FR4 trace	0 in	6 in	12 in	18 in	24 in	30 in	36 in
Insertion loss @ 6Gbps	-5.91 dB	-9.75 dB	-10.47 dB	-13.05 dB	-15.87 dB	-16.97 dB	-21.20 dB

HDMI Test Report

Overall Result: **PASS**

Test Configuration Details	
Device Description	
Device ID	Transmitter
Fixture Type	Other
Probe Connection	4 Probes
Probe Head Type	N5444A
Lane Connection	1 Data Lane
HDMI Specification	2.0
HDMI Test Type	TMDS Physical Layer Tests
Test Session Details	
Infiniium SW Version	05.20.0013
Infiniium Model Number	DSOX92504A
Infiniium Serial Number	MY54410104
Application SW Version	2.11
Debug Mode Used	No
Probe (Channel 1)	Model: N2801A Serial: US54094067 Head: N5444A Atten: Calibrated (18 FEB 2015 11:16:48), Using Cal Atten (5.7831E+000) Skew: Calibrated (18 FEB 2015 11:16:56), Using Cal Skew
Probe (Channel 2)	Model: N2801A Serial: US54094054 Head: N5444A Atten: Calibrated (18 FEB 2015 11:19:29), Using Cal Atten (5.5882E+000) Skew: Calibrated (18 FEB 2015 11:13:57), Using Cal Skew
Probe (Channel 3)	Model: N2801A Serial: US54094059 Head: N5444A Atten: Calibrated (18 FEB 2015 11:15:19), Using Cal Atten (5.7320E+000) Skew: Calibrated (18 FEB 2015 11:15:29), Using Cal Skew
Probe (Channel 4)	Model: N2801A Serial: US54094057 Head: N5444A Atten: Calibrated (18 FEB 2015 11:11:30), Using Cal Atten (5.5123E+000) Skew: Calibrated (18 FEB 2015 11:12:12), Using Cal Skew
Last Test Date	2016-01-21 16:43:22 UTC +08:00

Figure 7-19 HDMI 2.0 CTS Test Report

Summary of Results

Test Statistics	
Failed	0
Passed	24
Total	24

Margin Thresholds	
Warning	< 2 %
Critical	< 0 %

Pass	# Failed	# Trials	Test Name	Actual Value	Margin	Pass Limits
✓	0	1	<u>HF1-2: Clock Rise Time</u>	151.367 ps	101.8 %	VALUE >= 75.000 ps
✓	0	1	<u>HF1-2: Clock Fall Time</u>	150.838 ps	101.1 %	VALUE >= 75.000 ps
✓	0	1	<u>HF1-6: Clock Duty Cycle(Minimum)</u>	49.780	24.5 %	>=40%
✓	0	1	<u>HF1-6: Clock Duty Cycle(Maximum)</u>	50.330	16.1 %	<=60%
✓	0	1	<u>HF1-6: Clock Rate</u>	148.513500000 MHz	2.3 %	85.000000000 MHz <= VALUE <= 150.000000000 MHz
✓	0	1	<u>HF1-7: Differential Clock Voltage Swing, Vs (TP1)</u>	997 mV	25.4 %	400 mV < VALUE < 1.200 V
✓	0	1	<u>HF1-7: Clock Jitter (TP2 EQ with Worst Case Positive Skew)</u>	250 mTbit	16.7 %	VALUE <= 300 mTbit
✓	0	1	<u>HF1-7: Clock Jitter (TP2 EQ with Worst Case Negative Skew)</u>	225 mTbit	25.0 %	VALUE <= 300 mTbit
✓	0	1	<u>HF1-5: D0 Maximum Differential Voltage</u>	542 m	30.5 %	VALUE <= 780 m
✓	0	1	<u>HF1-5: D0 Minimum Differential Voltage</u>	-564 m	27.7 %	VALUE >= -780 m
✓	0	1	<u>HF1-2: D0 Rise Time</u>	135.000 ps	217.6 %	VALUE >= 42.500 ps
✓	0	1	<u>HF1-2: D0 Fall Time</u>	134.370 ps	216.2 %	VALUE >= 42.500 ps
✓	0	1	<u>HF1-8: D0 Mask Test (TP2 EQ with Worst Case Positive Skew)</u>	0.000	50.0 %	No Mask Failures
✓	0	1	<u>HF1-8: D0 Mask Test (TP2 EQ with Worst Case Negative Skew)</u>	0.000	50.0 %	No Mask Failures
✓	0	1	<u>HF1-1: VL Clock +</u>	2.684 V	48.0 %	2.300 V <= VALUE <= 3.100 V
✓	0	1	<u>HF1-1:Clock + VSwing</u>	513 mV	21.8 %	200 mV <= VALUE <= 600 mV
✓	0	1	<u>HF1-1: VL Clock -</u>	2.678 V	47.3 %	2.300 V <= VALUE <= 3.100 V
✓	0	1	<u>HF1-1:Clock - VSwing</u>	513 mV	21.8 %	200 mV <= VALUE <= 600 mV
✓	0	1	<u>HF1-4: Intra-Pair Skew - Clock</u>	51 mTbit	33.0 %	-150 mTbit <= VALUE <= 150 mTbit
✓	0	1	<u>HF1-1: VL D0+</u>	2.706 V	32.3 %	2.300 V <= VALUE <= 2.900 V
✓	0	1	<u>HF1-1: D0+ VSwing</u>	459 mV	29.5 %	400 mV <= VALUE <= 600 mV
✓	0	1	<u>HF1-1: VL D0-</u>	2.718 V	30.3 %	2.300 V <= VALUE <= 2.900 V
✓	0	1	<u>HF1-1: D0- VSwing</u>	450 mV	25.0 %	400 mV <= VALUE <= 600 mV
✓	0	1	<u>HF1-4: Intra-Pair Skew - Data Lane 0</u>	36 mTbit	38.0 %	-150 mTbit <= VALUE <= 150 mTbit

8. Mechanical/Packaging

8.1 Mechanical Outline

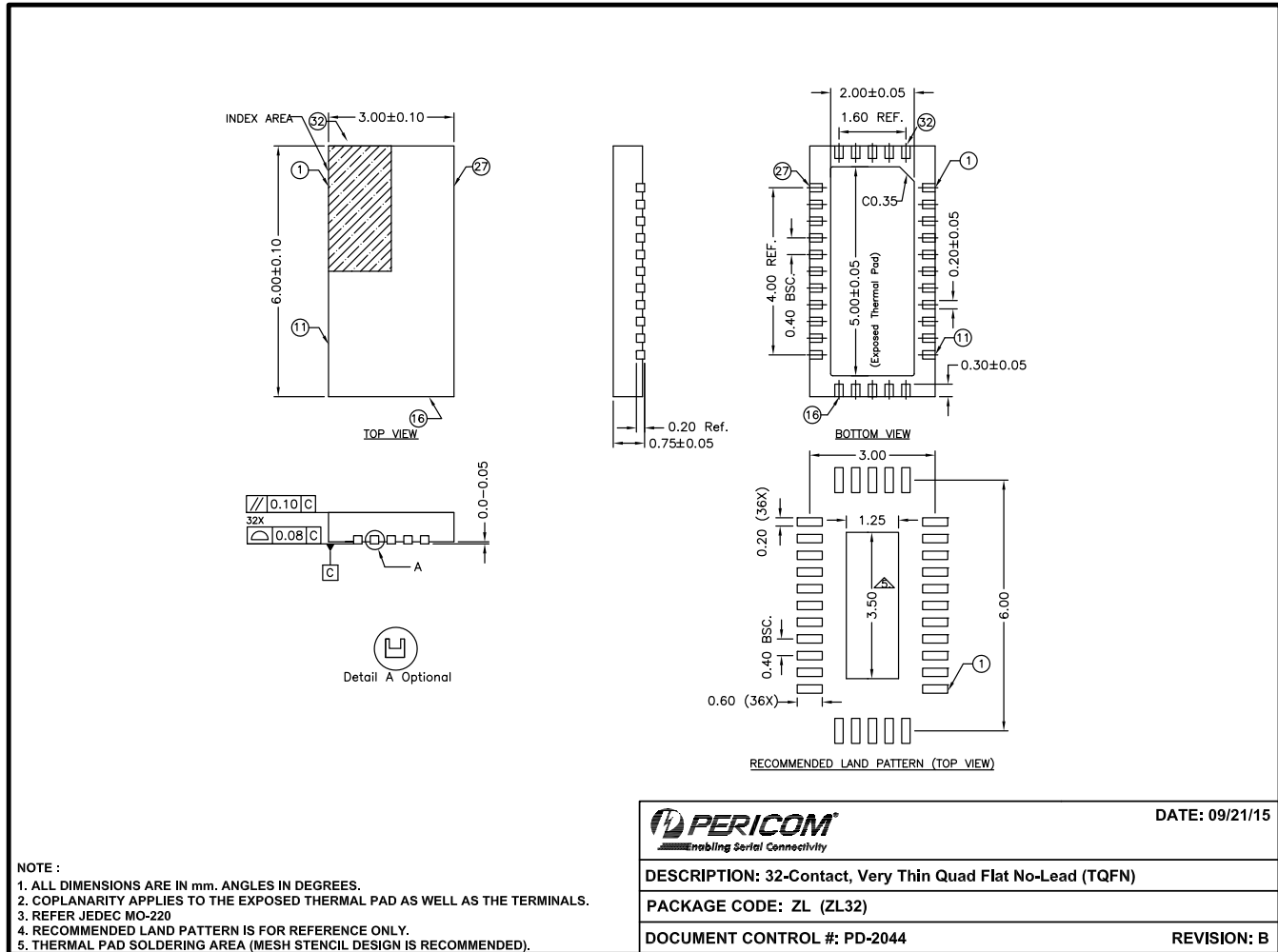

Figure 8-1 32-pin TQFN package mechanical

PI3HDX1204E

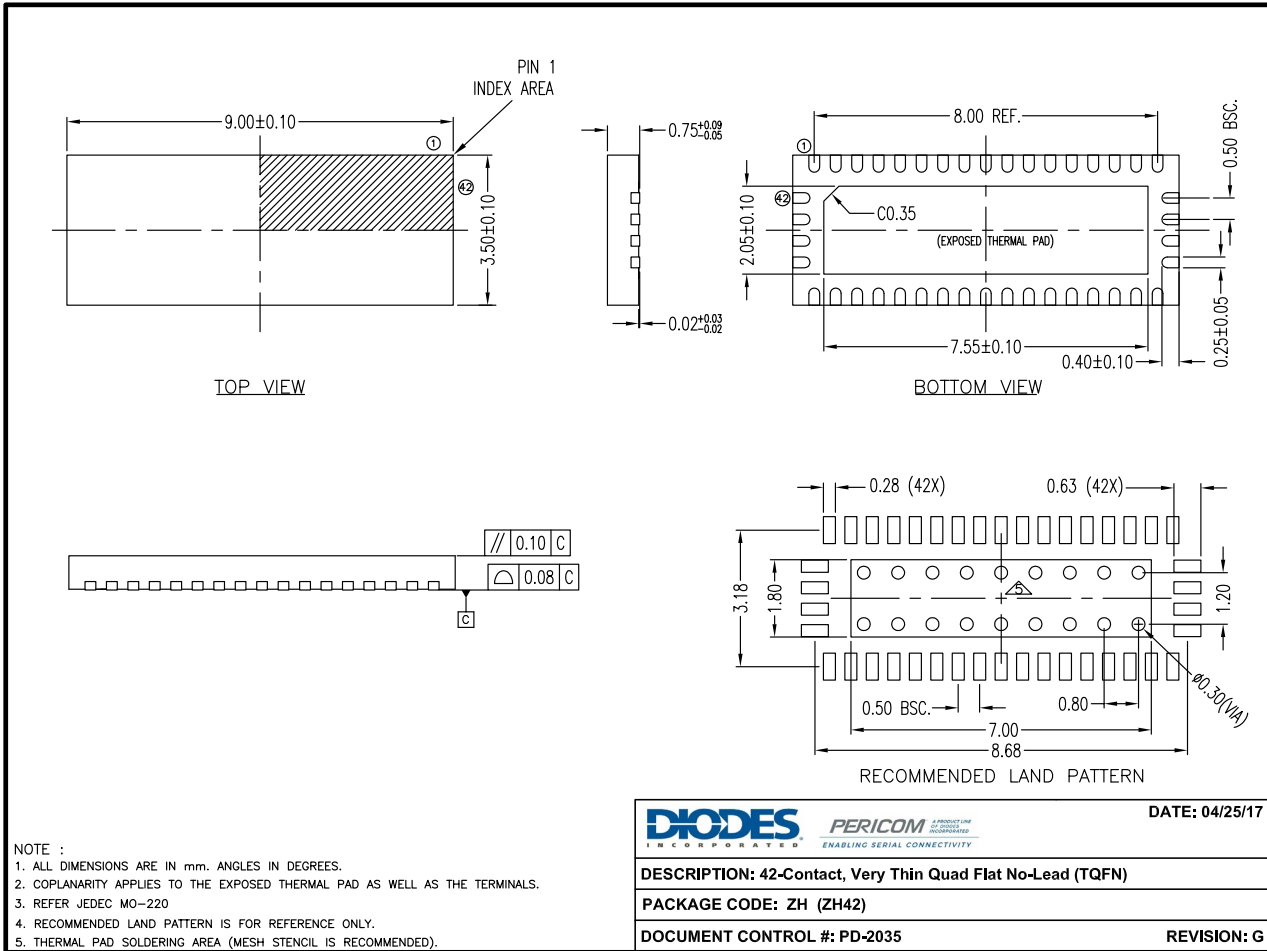

Figure 8-2 42-pin TQFN package mechanical

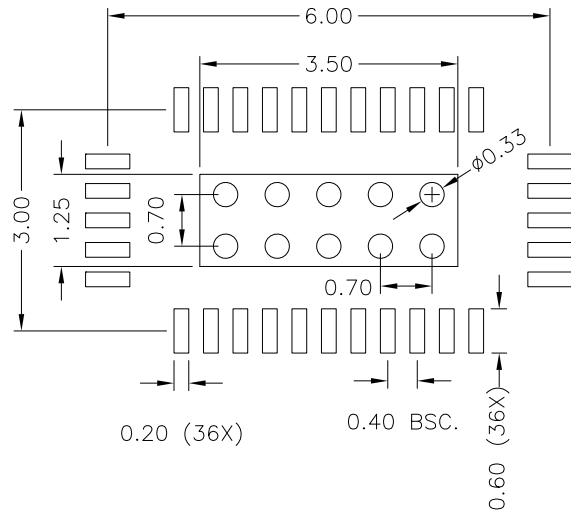

Figure 8-3 Thermal Via Pad Area: 32-pin

8.2 Part Marking Information

Product marking follows our standard part number ordering information.

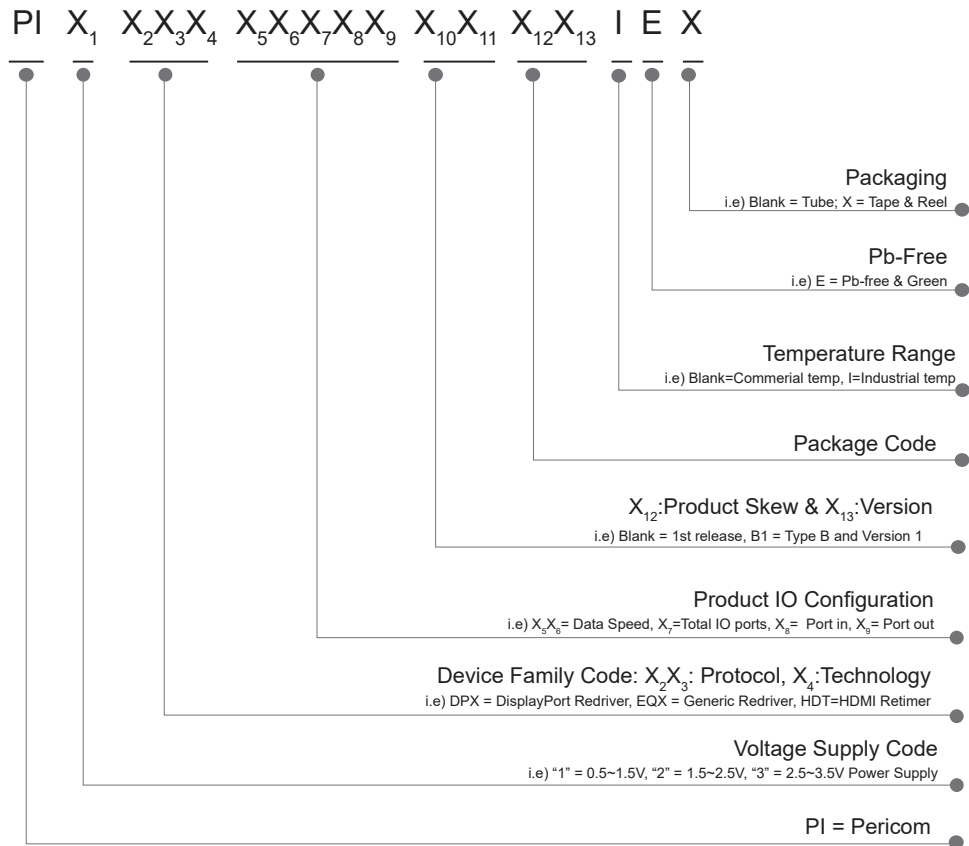
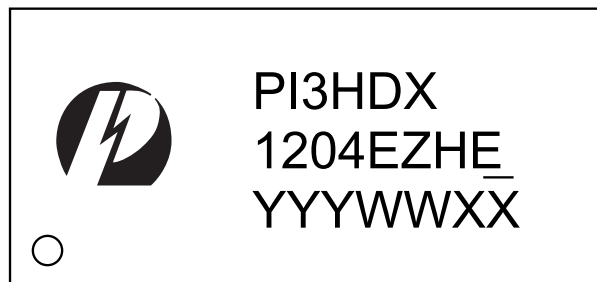

Figure 8-4 Part number information



1st Y: Die Rev
YY: Year
WW: Workweek
1st X: Assembly Code
2nd X: Fab Code

Figure 8-5 Package marketing information

8.3 Tape & Reel Materials and Design

8.3.1 Carrier Tape

The Pocketed Carrier Tape is made of Conductive Polystyrene plus Carbon material (or equivalent). The surface resistivity is $10^6 \Omega/\text{sq}$. maximum. Pocket tapes are designed so that the component remains in position for automatic handling after cover tape is removed. Each pocket has a hole in the center for automated sensing if the pocket is occupied or not, thus facilitating device removal. Sprocket holes along the edge of the center tape enable direct feeding into automated board assembly equipment. See Figures 3 and 4 for carrier tape dimensions.

8.3.2 Cover Tape

Cover tape is made of Anti-static Transparent Polyester film. The surface resistivity is $10^7 \Omega/\text{Sq}$. Minimum to 10^{11} Ohm sq . maximum. The cover tape is heat-sealed to the edges of the carrier tape to encase the devices in the pockets. The force to peel back the cover tape from the carrier tape shall be a MEAN value of 20 to 80gm (2N to 0.8N).

8.3.3 Reel

The device loading orientation is in compliance with EIA-481, current version (Figure 2). The loaded carrier tape is wound onto either a 13-inch reel, (Figure 4) or 7-inch reel. The reel is made of Anti-static High-Impact Polystyrene. The surface resistivity $10^7 \Omega/\text{sq}$. minimum to $10^{11} \Omega/\text{sq}$. max.

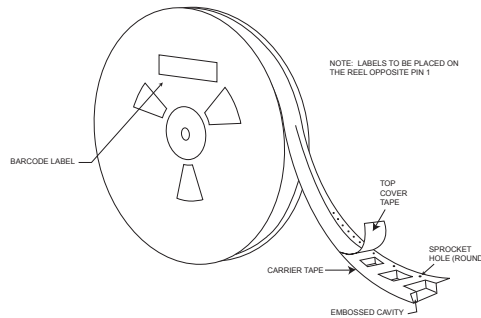

Figure 8-6 Tape & Reel label information

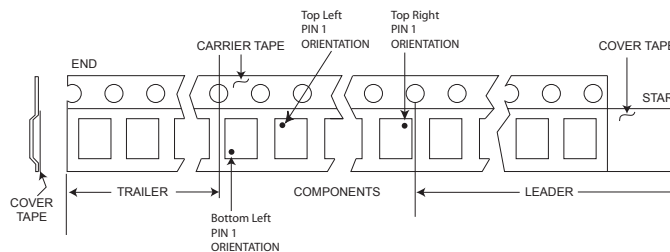

Figure 8-7 Tape leader and trailer pin 1 orientations

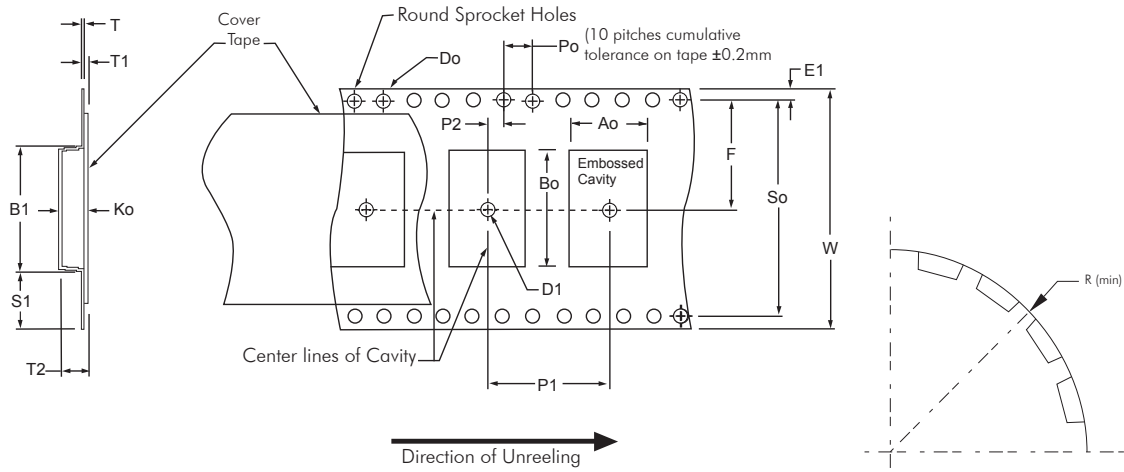

Figure 8-8 Standard embossed carrier tape dimensions

Table 8-1. Constant Dimensions

Tape Size	D0	D1 (Min)	E1	P0	P2	R (See Note 2)	S1 (Min)	T (Max)	T1 (Max)
8mm	1.5 +0.1 -0.0	1.0	1.75 ± 0.1	4.0 ± 0.1	2.0 ± 0.05	25	0.6	0.6	0.1
12mm		1.5				2.0 ± 0.1			
16mm					2.0				
24mm		2.0 ± 0.15							
32mm									
44mm									

Table 8-2. Variable Dimensions

Tape Size	P1	B1 (Max)	E2 (Min)	F	So	T2 (Max.)	W (Max)	A0, B0, & K0
8mm	Specific per package type. Refer to FR-0221 (Tape and Reel Packing Information)	4.35	6.25	3.5 ± 0.05	N/A (see note 4)	2.5	8.3	See Note 1
12mm		8.2	10.25	5.5 ± 0.05		6.5	12.3	
16mm		12.1	14.25	7.5 ± 0.1		8.0	16.3	
24mm		20.1	22.25	11.5 ± 0.1	12.0	24.3		
32mm		23.0	N/A	14.2 ± 0.1		28.4 ± 0.1	32.3	
44mm		35.0	N/A	20.2 ± 0.15	40.4 ± 0.1	16.0	44.3	

NOTES:

- A0, B0, and K0 are determined by component size. The cavity must restrict lateral movement of component to 0.5mm maximum for 8mm and 12mm wide tape and to 1.0mm maximum for 16,24,32, and 44mm wide carrier. The maximum component rotation within the cavity must be limited to 20o maximum for 8 and 12 mm carrier tapes and 10o maximum for 16 through 44mm.
- Tape and components will pass around reel with radius "R" without damage.
- S1 does not apply to carrier width ≥32mm because carrier has sprocket holes on both sides of carrier where Do≥S1.
- So does not exist for carrier ≤32mm because carrier does not have sprocket hole on both side of carrier.

Table 8-3. Reel dimensions by tape size

Tape Size	A	N (Min) See Note A	W1	W2 (Max)	W3	B (Min)	C	D (Min)
8mm	178 ±2.0mm or 330±2.0mm	60 ±2.0mm or 100±2.0mm	8.4 +1.5/-0.0 mm	14.4 mm	Shall Ac- commo- date Tape Width Without Interfer- ence	1.5mm	13.0 +0.5/-0.2 mm	20.2mm
12mm			12.4 +2.0/- 0.0 mm	18.4 mm				
16mm	330 ±2.0mm	100 ±2.0mm	16.4 +2.0/- 0.0 mm	22.4 mm				
24mm			24.4 +2.0/- 0.0 mm	30.4 mm				
32mm			32.4 +2.0/-0.0 mm	38.4 mm				
44mm			44.4 +2.0/-0.0 mm	50.4 mm				

NOTE:

A. If reel diameter A=178 ±2.0mm, then the corresponding hub diameter (N(min)) will by 60 ±2.0mm. If reel diameter A=330±2.0mm, then the corresponding hub diameter (N(min)) will by 100±2.0mm.

9. Important Notice

DIODES INCORPORATED MAKES NO WARRANTY OF ANY KIND, EXPRESS OR IMPLIED, WITH REGARDS TO THIS DOCUMENT, INCLUDING, BUT NOT LIMITED TO, THE IMPLIED WARRANTIES OF MERCHANTABILITY AND FITNESS FOR A PARTICULAR PURPOSE (AND THEIR EQUIVALENTS UNDER THE LAWS OF ANY JURISDICTION).

Diodes Incorporated and its subsidiaries reserve the right to make modifications, enhancements, improvements, corrections or other changes without further notice to this document and any product described herein. Diodes Incorporated does not assume any liability arising out of the application or use of this document or any product described herein; neither does Diodes Incorporated convey any license under its patent or trademark rights, nor the rights of others. Any Customer or user of this document or products described herein in such applications shall assume all risks of such use and will agree to hold Diodes Incorporated and all the companies whose products are represented on Diodes Incorporated website, harmless against all damages. Diodes Incorporated does not warrant or accept any liability whatsoever in respect of any products purchased through unauthorized sales channel.

Should Customers purchase or use Diodes Incorporated products for any unintended or unauthorized application, Customers shall indemnify and hold Diodes Incorporated and its representatives harmless against all claims, damages, expenses, and attorney fees arising out of, directly or indirectly, any claim of personal injury or death associated with such unintended or unauthorized application.

Products described herein may be covered by one or more United States, international or foreign patents pending. Product names and markings noted herein may also be covered by one or more United States, international or foreign trademarks.

This document is written in English but may be translated into multiple languages for reference. Only the English version of this document is the final and determinative format released by Diodes Incorporated.

LIFE SUPPORT

Diodes Incorporated products are specifically not authorized for use as critical components in life support devices or systems without the express written approval of the Chief Executive Officer of Diodes Incorporated. As used herein:

A. Life support devices or systems are devices or systems which:

1. are intended to implant into the body, or
2. support or sustain life and whose failure to perform when properly used in accordance with instructions for use provided in the labeling can be reasonably expected to result in significant injury to the user.

B. A critical component is any component in a life support device or system whose failure to perform can be reasonably expected to cause the failure of the life support device or to affect its safety or effectiveness.

Customers represent that they have all necessary expertise in the safety and regulatory ramifications of their life support devices or systems, and acknowledge and agree that they are solely responsible for all legal, regulatory and safety-related requirements concerning their products and any use of Diodes Incorporated products in such safety-critical, life support devices or systems, notwithstanding any devices- or systems-related information or support that may be provided by Diodes Incorporated. Further, Customers must fully indemnify Diodes Incorporated and its representatives against any damages arising out of the use of Diodes Incorporated products in such safety-critical, life support devices or systems.

Copyright © 2016, Diodes Incorporated
www.diodes.com

--



Компания «ЭлектроПласт» предлагает заключение долгосрочных отношений при поставках импортных электронных компонентов на взаимовыгодных условиях!

Наши преимущества:

- Оперативные поставки широкого спектра электронных компонентов отечественного и импортного производства напрямую от производителей и с крупнейших мировых складов;
- Поставка более 17-ти миллионов наименований электронных компонентов;
- Поставка сложных, дефицитных, либо снятых с производства позиций;
- Оперативные сроки поставки под заказ (от 5 рабочих дней);
- Экспресс доставка в любую точку России;
- Техническая поддержка проекта, помощь в подборе аналогов, поставка прототипов;
- Система менеджмента качества сертифицирована по Международному стандарту ISO 9001;
- Лицензия ФСБ на осуществление работ с использованием сведений, составляющих государственную тайну;
- Поставка специализированных компонентов (Xilinx, Altera, Analog Devices, Intersil, Interpoint, Microsemi, Aeroflex, Peregrine, Syfer, Eurofarad, Texas Instrument, Miteq, Cobham, E2V, MA-COM, Hittite, Mini-Circuits, General Dynamics и др.);

Помимо этого, одним из направлений компании «ЭлектроПласт» является направление «Источники питания». Мы предлагаем Вам помощь Конструкторского отдела:

- Подбор оптимального решения, техническое обоснование при выборе компонента;
- Подбор аналогов;
- Консультации по применению компонента;
- Поставка образцов и прототипов;
- Техническая поддержка проекта;
- Защита от снятия компонента с производства.



Как с нами связаться

Телефон: 8 (812) 309 58 32 (многоканальный)

Факс: 8 (812) 320-02-42

Электронная почта: org@eplast1.ru

Адрес: 198099, г. Санкт-Петербург, ул. Калинина, дом 2, корпус 4, литера А.