

THIS DRAWING IS UNPUBLISHED. RELEASED FOR PUBLICATION
 © COPYRIGHT - By TE CONNECTIVITY ALL RIGHTS RESERVED.

LOC	DIST	REVISIONS					
HB	-	P	LTR	DESCRIPTION	DATE	DWN	APVD
			D	ADD LOT.NO SYSTEM, SEE NOTE.5	ECO-12-014659	20-AUG-12	FS.H B.H.Y

D

D

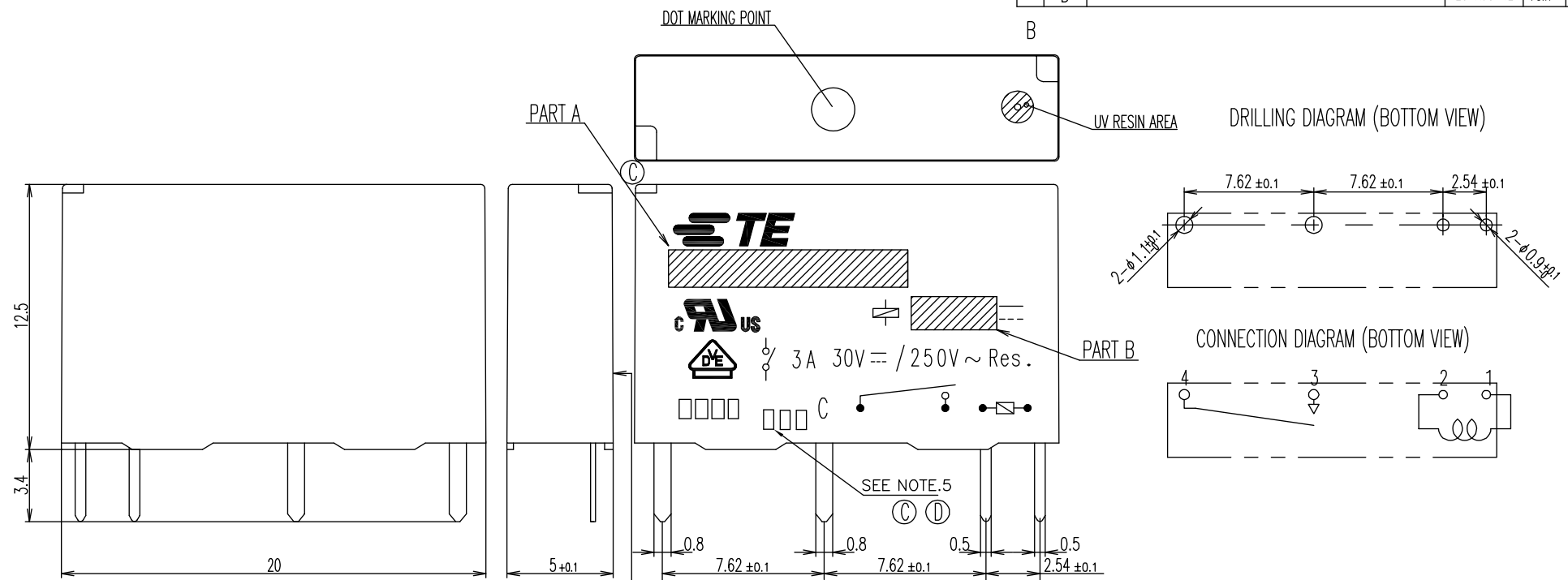

NOTE:
 1. TERMINAL DIMENSION IS AFTER SOLDER DIP
 SOLDER DIP: Sn-3Ag-0.5Cu
 2. LOT NO. SYSTEM AS FOLLOWING;

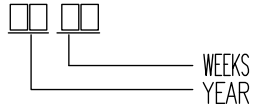

- ③ 3. MARKING FROM INK CHANGE TO LASER
- ④ 4. ONE CHARACTER DISTINGUISH THE LINE IDENTITY, SUCH AS: A, B, ...
- ⑤ 5. ADD LOT NO. SYSTEM AS FOLLOWING;

I, DIGITS FOR DAY OF THE WEEK
 1...MONDAY IN THIS WEEK;
 2...TUESDAY IN THIS WEEK;

 7...SUNDAY IN THIS WEEK
 II, DIGITS FOR SHIFT OF THE DAY
 1...DAY SHIFT IN THIS DAY;
 2...NIGHT SHIFT IN THIS DAY;
 III, ONE CHARACTER DISTINGUISH THE LINE IDENTITY, SUCH AS: A,B,.....Z

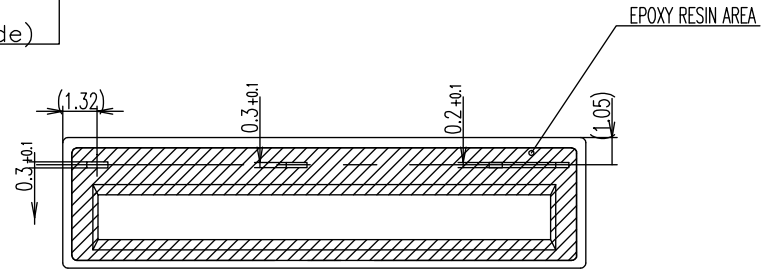

Diagram dimension	Tolerance
0.99mm max	±0.1mm
1 - 2.99mm	±0.2mm
3mm min	±0.3mm

① 2. MEET UL1604
 UL1604 部品

A

A

THIS DRAWING IS A CONTROLLED DOCUMENT.		DWN Y.OKAMOTO			
DIMENSIONS: mm		CHK M.MOCHIZUKI			
TOLERANCES UNLESS OTHERWISE SPECIFIED.		APVD A.NAGAI		NAME	
0 PLC ± - 1 PLC ± - 2 PLC ± - 3 PLC ± - 4 PLC ± - ANGLES ± - FINISH		PRODUCT SPEC		PCN-1**D3MHZ,100 CUSTOMER DRAWING	
MATERIAL		WEIGHT		SIZE	RESTRICTED TO
-		-		A3 00779	-
CUSTOMER DRAWING				DRAWING NO	C=1721095
				SCALE	SHEET
				5:1	1 OF 2
				REV	D

THIS DRAWING IS UNPUBLISHED. RELEASED FOR PUBLICATION
 © COPYRIGHT - By TE CONNECTIVITY ALL RIGHTS RESERVED.

LOC	DIST	REVISIONS					
HB	-	P	LTR	DESCRIPTION	DATE	DWN	APVD
		-		SEE SHEET 1	-	-	-



02

15	UV RESIN	AR	AR
14	CASE	1	1
13	EPOXY	AR	AR
12	MAGNETIC WIRE	AR	AR
11	CARD	1	1
10	ARMATURE	1	1
9	STATIONARY CONTACT	1	1
8	STATIONARY TERMINAL	1	1
7	MOVABLE CONTACT	2	2
6	MOVABLE TERMINAL	1	1
5	BASE	1	1
4	CORE	1	1
3	COIL TERMINAL B	1	1
2	COIL TERMINAL A	1	1
1	BOBBIN	1	1
ITEM	DESCRIPTION	a	A

PARTS LIST

	24V	PCN-124D3MHZ	1-1721095-8	PCN-124D3MHZ,100	107-79043 (TRAY)	108-79629	REINFORCED INSURATION WASHABLE TYPE	A
PRELIMINARY	23.5V	PCN-123D3MHZ	1-1721095-7	PCN-123D3MHZ,100	107-79043 (TRAY)	108-79628		
	18V	PCN-118D3MHZ	1-1721095-6	PCN-118D3MHZ,100	107-79043 (TRAY)	108-79627		
	12V	PCN-112D3MHZ	1-1721095-5	PCN-112D3MHZ,100	107-79043 (TRAY)	108-79626		
	9V	PCN-109D3MHZ	1-1721095-4	PCN-109D3MHZ,100	107-79043 (TRAY)	108-79625		
PRELIMINARY	6V	PCN-106D3MHZ	1-1721095-3	PCN-106D3MHZ,100	107-79043 (TRAY)	108-79624		
	5V	PCN-105D3MHZ	1-1721095-2	PCN-105D3MHZ,100	107-79043 (TRAY)	108-79623		
	4.5V	PCN-104D3MHZ	1-1721095-1	PCN-104D3MHZ,100	107-79043 (TRAY)	108-79622		
PRELIMINARY	3V	PCN-103D3MHZ	1-1721095-0	PCN-103D3MHZ,100	107-79043 (TRAY)	108-79621		
DESCRIPTION	PART B	PART A	TE PART NO	EC TYPE NAME	PACKING SPECIFICATION	PRODUCT SPEC	DESCRIPTION	No.

	24V	PCN-124D3MHZ	1721095-9	PCN-124D3MHZ,100	107-79039 (TUBE)	108-79629	REINFORCED INSURATION WASHABLE TYPE	a
PRELIMINARY	23.5V	PCN-123D3MHZ	1721095-8	PCN-123D3MHZ,100	107-79039 (TUBE)	108-79628		
	18V	PCN-118D3MHZ	1721095-7	PCN-118D3MHZ,100	107-79039 (TUBE)	108-79627		
	12V	PCN-112D3MHZ	1721095-6	PCN-112D3MHZ,100	107-79039 (TUBE)	108-79626		
	9V	PCN-109D3MHZ	1721095-5	PCN-109D3MHZ,100	107-79039 (TUBE)	108-79625		
PRELIMINARY	6V	PCN-106D3MHZ	1721095-4	PCN-106D3MHZ,100	107-79039 (TUBE)	108-79624		
	5V	PCN-105D3MHZ	1721095-3	PCN-105D3MHZ,100	107-79039 (TUBE)	108-79623		
	4.5V	PCN-104D3MHZ	1721095-2	PCN-104D3MHZ,100	107-79039 (TUBE)	108-79622		
PRELIMINARY	3V	PCN-103D3MHZ	1721095-1	PCN-103D3MHZ,100	107-79039 (TUBE)	108-79621		
DESCRIPTION	PART B	PART A	TE PART NO	EC TYPE NAME	PACKING SPECIFICATION	PRODUCT SPEC	DESCRIPTION	No.

THIS DRAWING IS A CONTROLLED DOCUMENT.		DWN Y.OKAMOTO			
		CHK M.MOCHIZUKI			
DIMENSIONS: mm		TOLERANCES UNLESS OTHERWISE SPECIFIED:		NAME A.NAGAI	
		0 PLC ± -		APVD A.NAGAI	
		1 PLC ± -		PRODUCT SPEC	
		2 PLC ± -		APPLICATION SPEC	
		3 PLC ± -		WEIGHT	
		4 PLC ± -		A3 00779	
		ANGLES ± -		DRAWING NO C-1721095	
MATERIAL		FINISH		RESTRICTED TO	
				-	
CUSTOMER DRAWING				SCALE 5:1 SHEET 2 OF 2 REV D	



Компания «ЭлектроПласт» предлагает заключение долгосрочных отношений при поставках импортных электронных компонентов на взаимовыгодных условиях!

Наши преимущества:

- Оперативные поставки широкого спектра электронных компонентов отечественного и импортного производства напрямую от производителей и с крупнейших мировых складов;
- Поставка более 17-ти миллионов наименований электронных компонентов;
- Поставка сложных, дефицитных, либо снятых с производства позиций;
- Оперативные сроки поставки под заказ (от 5 рабочих дней);
- Экспресс доставка в любую точку России;
- Техническая поддержка проекта, помощь в подборе аналогов, поставка прототипов;
- Система менеджмента качества сертифицирована по Международному стандарту ISO 9001;
- Лицензия ФСБ на осуществление работ с использованием сведений, составляющих государственную тайну;
- Поставка специализированных компонентов (Xilinx, Altera, Analog Devices, Intersil, Interpoint, Microsemi, Aeroflex, Peregrine, Syfer, Eurofarad, Texas Instrument, Miteq, Cobham, E2V, MA-COM, Hittite, Mini-Circuits, General Dynamics и др.);

Помимо этого, одним из направлений компании «ЭлектроПласт» является направление «Источники питания». Мы предлагаем Вам помощь Конструкторского отдела:

- Подбор оптимального решения, техническое обоснование при выборе компонента;
- Подбор аналогов;
- Консультации по применению компонента;
- Поставка образцов и прототипов;
- Техническая поддержка проекта;
- Защита от снятия компонента с производства.



Как с нами связаться

Телефон: 8 (812) 309 58 32 (многоканальный)

Факс: 8 (812) 320-02-42

Электронная почта: org@eplast1.ru

Адрес: 198099, г. Санкт-Петербург, ул. Калинина, дом 2, корпус 4, литера А.